

ASSEMBLY INSTRUCTIONS

200 Series

Light Utility Vehicle

Congratulations on the purchase of your Light Utility Vehicle! These instructions will guide you through the assembly process. Carefully read these instructions and familiarize yourself with the tools and fasteners required before starting the assembly of your vehicle.

Fasteners required for assembly

Please refer to the last page of instructions for an illustrated list of fasteners. Ensure that you have all the fasteners before starting the assembly of your vehicle. Note that some fasteners may be pre-installed into some of the overhead bars.

Tools required for assembly

Please gather the required tools and familiarize yourself with them before starting the assembly of your vehicle. The tools will be mentioned in *italic* text for easy recognition.

<i>Hammer</i>	<i>Box Cutter</i>	<i>Pry Bar</i>
<i>Safety Glasses</i>	<i>Socket Wrench</i>	<i>10mm Socket</i>
<i>12mm Wrench</i>	<i>Phillips Screw Driver</i>	

WARNING

Wear proper eye protection during the uncrating and assembly process to avoid potential eye injuries.

WARNING

RISK OF SERIOUS INJURY OR DEATH
The Brush Bars and the Shoulder Belts are critical parts of the Operator / Passenger safety system on this vehicle. Do not attempt to operate the unit until these components have been properly installed.

I. Uncrating the vehicle (Fig 1)

- Wear your *Safety Glasses* to prevent eye injury.
- Using the *Hammer* and *Pry Bar*, remove cross supports at each end of the crate and discard.
- Carefully pry and remove crate top and discard.
- Remove crate sides and discard
- Using a *Box Cutter*, cut and remove the hold down ties.
- Remove the vehicle from the crate base and discard base.

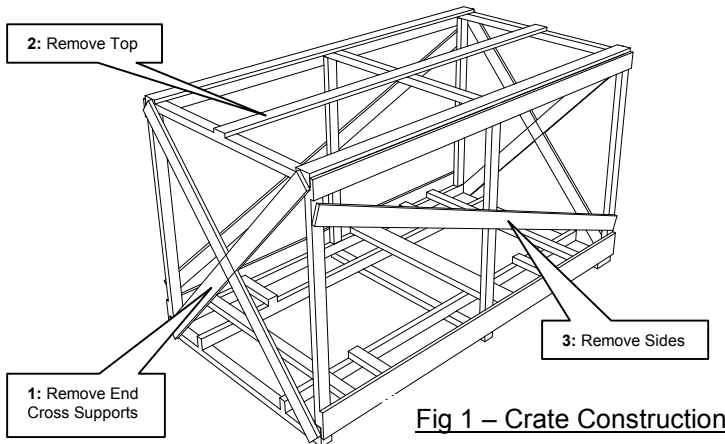

Fig 1 – Crate Construction

II. Unpacking the Component Parts

- Unpack all of the loose component parts from the unit and set aside. Be sure to look in the under seat storage compartment for bars, hardware or literature.
- Remove any protective plastic from each component and discard.

III. Overhead Bar Installation (Figs 2 and 3)

- Locate the **C-Pillar** and fasteners: (2) 14697, (4) 14837, (4) 14944, and (2) 14088. (Reference Fastener Illustration on page 2.)
- Locate the rubber connector seals (6) 14941, and rubber fastener caps (16) 14945 packaged in the customer hardware kit.
- Slip the connector seal on the ends of each overhead bar where it will connect to the main frame (ref Figs 2 and 3)
- Set the C-Pillar in place, with the electrical plug located behind the driver seat as shown. Push the connector seals down to the joint and install the fasteners with a *12mm Wrench* and *10mm Socket Wrench*. DO NOT tighten the fasteners at this time. Ensure that seat belts are not twisted or wrapped around C-Pillar.

- Locate the **A-Pillars** and fasteners: (4) 14697, (6) 14837, (6) 14944, and (2) 14088. Install the connector seals as shown on the diagram below.
- Set the A-Pillars in place, slide the connector seals down, and install the fasteners with a *12mm Wrench* and *10mm Socket Wrench*. DO NOT tighten the fasteners at this time. (Note: *Seatbelt decals should be facing away from the vehicle as shown in the illustration below*).
- Locate the **Overhead Cross Bar** and fasteners: (3) 14697, (3) 14837, (2) 14944.
- Place the bar as shown in the illustration below and install the fasteners using a *10mm Socket Wrench*. DO NOT tighten any fasteners at this time. (Note: *Clamp the cargo light between the 14836 bolt head and the 14697 concave washer and ensure that there is adequate wire slack*).

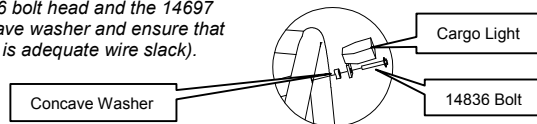

- Locate the **B-Pillars** and fasteners: (4) 14697, (6) 14837, (6) 14944, and (2) 14088. (Note: *B-Pillars are universal RH/LH*)
- Install the connector seals as shown. Set the B-Pillars in place and install the fasteners with a *12mm Wrench* and a *10mm Socket Wrench*.
- Tighten all fasteners using the *12mm Wrench* and *10mm Socket Wrench*. Ensure that all connector seals are pushed down to the frame connection.
- Install all fastener caps.

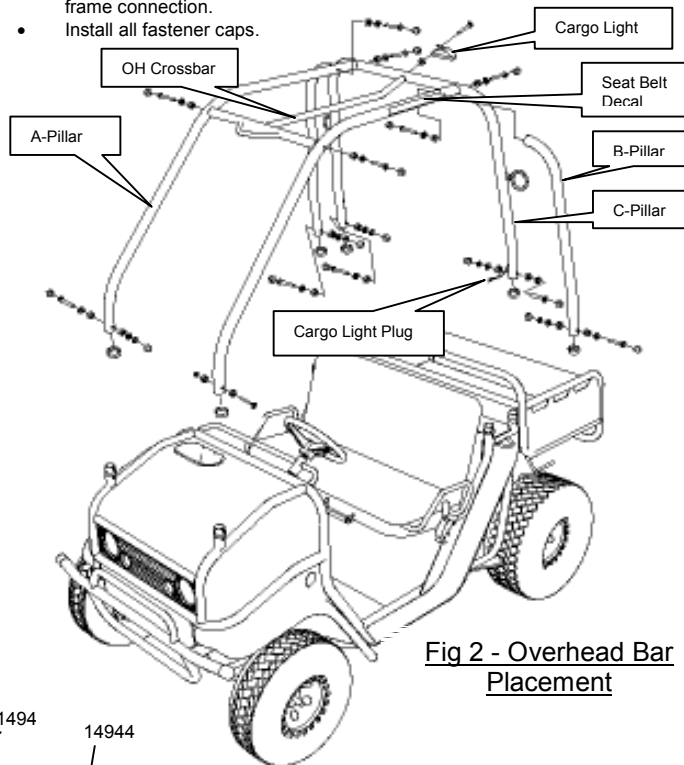

Fig 2 - Overhead Bar Placement

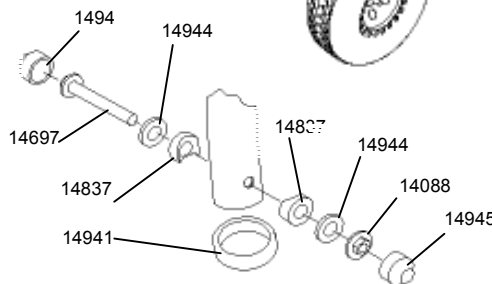

Fig 3 – Connection Detail

IV. Final Preparation

- Connect the electrical plug exposed from the C-Pillar to the loose connector located between the bed and the driver seat.
- Seat belts should be checked to ensure that they are not twisted or binding. As well, the forked seat belt retainer clips need to be removed and discarded. (Ref fastener illustration on page 2)
- Fill the fuel tank with clean, fresh, mid-grade (89-93 Octane) gasoline per the supplied Owner/Operator Manual.

200 Series

Light Utility Vehicle

- Check the engine oil level and tire pressure per the supplied Owner/Operator Manual.

WARNING

Avoid risk of serious injury or death. It is important to first read and understand the Owner/Operator Manual and follow all instructions and warnings. If you do not understand this, or any other warning supplied with your vehicle, contact your dealer or ASW customer service at 1-800-643-7332 before using this vehicle.

INITIAL STARTUP INSTRUCTIONS

V. Battery Connection

NOTE: Ensure that the connections are correct. Reversing the wires to the battery terminals may cause the inline fuse to blow.

- This unit has been supplied with a pre-charged battery. While every effort has been made to ensure that the battery will maintain its charge, it may require additional charging by the retailer or consumer. Additionally, the leads have been disconnected to preserve its charge. Prior to starting, the leads must be connected to the (+) and (-) terminals of the battery.
- Using a *Phillips Screwdriver*, connect the RED wire to the (+) battery terminal as indicated on the battery casing.
- Using a *Phillips Screwdriver*, connect the GREEN wire to the (-) battery terminal as indicated on the battery casing.

VI. Initial (First Time) Startup

NOTE: Lost or stolen keys can be replaced by calling American Sportworks customer service at 1-800-643-7332.

- Check the engine oil level per the Owner/Operator Manual.
- Set the parking brake per the Owner/Operator Manual.
- Ensure that the vehicle is shifted into the NEUTRAL gear.
- Ensure that the parking brake is applied.
- Ensure that the engine stop switch (located on the rear swingarm on the electrical box) is in the "RUN" position
- While sitting in the vehicle, pump the accelerator pedal several times to ensure that it returns freely
- With one foot on the brake pedal, start the engine by turning the ignition key; holding for no longer than 5 second intervals, until the fuel line and carburetor fill with gas. (Note: The unit is shipped with a dry carburetor and fuel line. Several starting intervals may be required in order to draw fuel into the carburetor)
- After the unit has started, allow it to warm up for a period of 5 minutes before driving to allow the auto-enrichener (choke) to fully close. DO NOT depress the accelerator pedal during the warming period.
- DO NOT drive the unit until the Owner/Operator manual has been fully read and understood.

NOTE TO RETAILER

VII. Display Recommendations

The following recommendations have been provided to ensure that this unit retains its factory appearance and remains in optimal running condition for the final purchaser. Following these recommendations will greatly reduce problems associated with extended storage and infrequent use of this vehicle which are typically associated with display models of power equipment.

- Practice regular Inventory Rotation. First in / First Out.
- DO NOT connect or charge the battery until the point of sale. This will ensure that the battery has not been discharged through low current draw over time, or frequent, but short engine starting cycles.
- Batteries stored in extreme cold may freeze, causing damage. Store batteries indoors when possible to avoid freezing.
- DO NOT add fuel to the vehicle until the point of sale. Storage of fuel in the carburetor and in the fuel tank increases the opportunity for stale gas, moisture draw, or clogged carburetors.
- DO store the unit indoors for display whenever possible. While the powder coated finish of this vehicle is designed for rough service, weathering and fading may occur if the unit is exposed to the outdoor elements for extended periods of time.

The previous recommendations are optimal for the display of this vehicle. IF, however, the unit must be displayed in a fully operational condition, be aware that it will require additional care and maintenance of the battery and fuel system. These guidelines should be followed for display of an operational unit.

- DO apply a periodic trickle charge to maintain the battery at an appropriate voltage level. Batteries stored in extreme cold may freeze, causing damage. Remove and store batteries indoors during the winter months to avoid freezing.
- DO keep the fuel tank filled to capacity with 89-93 Octane gasoline blended with a quality fuel stabilizer designed for small engines. A full tank eliminates moist air and potential condensation issues.
- DO start the unit periodically to allow the internal engine parts to coat with oil and to flush any stale fuel from the carburetor.
- DO NOT start and run the unit for short time periods. IF the unit IS started, allow it to idle for a 15 minute time period. This allows the engine to reach operating temperature, allows the battery to charge and minimizes fouling issues with the spark plug.
- DO shut off the engine while the engine is at high RPM. This will allow accumulated fuel to burn off the plug prior to engine shut down.

Contact American Sportworks Customer Service for questions or problems that may arise with the assembly and starting of this unit at 1-800-643-7332.

