



Garden Party™ 10ft X 10ft

10ft Wide x 10ft Deep x 6ft3in Side Height /
9ft7in Center Height



King Canopy Item #: GP1010

With 4 Legs, Foot Pads, Cover & Screens.

Distributed by:
PIC America, LTD.
1730 Five Points Lane • Fuquay-Varina, NC 27526
1-800-800-6296 • www.kingcanopy.com

WARNING:

Keep all flame and heat sources away from this tent fabric. Meets the flammability requirements of CPAI-84 Section 6 and NFPA-701. It is not fire proof. The fabric will burn if left in continuous contact with any flame source.



PARTS LIST

6X6PC

12 pc 78" Pipe



2X9PC

4 pc 33" Swedge pipe



4WCPC

4 pc 4-way connectors

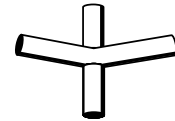

FEET

4 pc Foot pads



2-PC

2 pc 2 piece white powder coated fitting



GPT10

1 pc 100% Polyester Cover with Screens

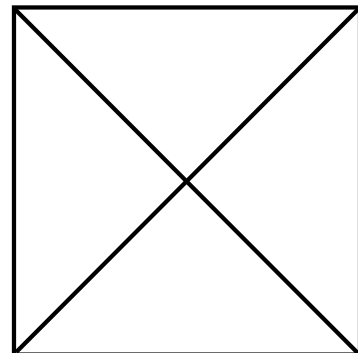

FRAME ASSEMBLY



1. Arrange all pipes and fittings on the ground as in Figure #1.
2. Insert one swaged pipe into one long straight pipe. This extended pipe will be inserted into each of the corner fittings to form the length of the sides. Insert short swaged pipe into long pipe and then into each of the corner fittings to form roof supports. (Figure #3)
3. To form peak, insert two of the roof pipe into the ends of one of the two-piece center fitting (Figure #4). Repeat for the other cross peak sections. Peak fittings will overlap. (Figure #4) Push the pipe into the fittings until it stops.
4. Place cover over the frame.
5. Lift one side of the frame and insert two long pipes for the legs. Repeat on the other side.
6. Slide one foot on each leg.
7. Pull cover down on all four sides of the frame.
8. Place the D ring that is attached to the cover leg valance over the hook of each foot. (Figure #4) Pull strap to tighten each leg valance. Tighten evenly at every leg. DO NOT OVERTIGHTEN, IT WILL TEAR.
9. Attach straps on the underside of the cover around frame.
10. This canopy is designed for use of a temporary structure. Canopies may excellent kites. If the canopy is not anchored, winds could cause the canopy to take flight. We suggest screw in anchor and rope to attach to the D ring on the cover at the top of each leg. When using D rings to anchor the unit, make sure the straps that are attached to the inside of the cover at the D ring are tied to the frame. WEATHER RELATED DAMAGE IS NOT COVERED UNDER WARRANTY.
11. Attach the screening as you would a shower curtain. SEE NEXT PAGE FOR FURTHER INSTRUCTION ON SCREEN ASSEMBLY.
12. ANCHORING UNITS ARE STRONGLY ADVISED! Anchors are not included due to the various landscapes and personal choices of each individual customer. You may purchase screw in anchors at your local hardware store or home improvement center or call toll free 1-800-800-6296 to purchase one of our kit.

Figure #2

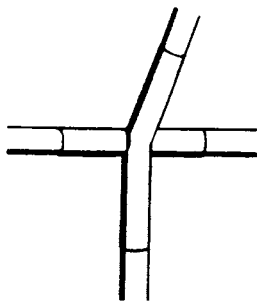

Figure #3

Figure #4

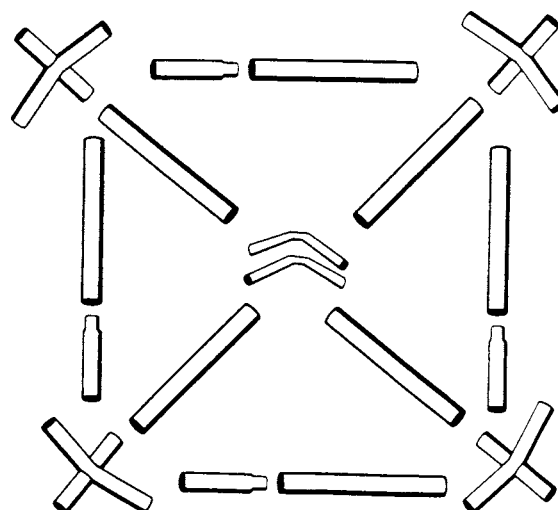
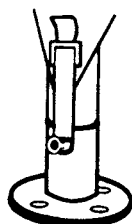

Figure #1



SCREEN ASSEMBLY

1. Position screens on outside of the leg poles with the elastic ties facing out (Figure #1). Screens attach to the top frame like shower curtains using the included rings. (Figure #2)

Figure #1



Figure #2



2. Tie the strap around the corner fitting at the top. (Inset Figure #2)

SCREEN ASSEMBLY



3. Attach the screens to the leg poles with the elastic ties as shown (Figure #3).

Figure #3



4. Now you can either zipper the screens together or tie the screens back by securing the elastic tie strap around the screens and attaching them to the ties that are holding the screen walls at the legs. (Figure #4)

Figure #4





ANCHORING YOUR UNIT

This canopy is designed for use as a temporary structure. After assembly, the canopy **MUST BE** securely anchored to the ground to prevent damage from winds. Your canopy will act like a kite in the wind if not properly and securely anchored to the ground. Severe winds will cause the frame to twist and unanchored legs will fall, thereby collapsing the canopy. If severe winds are expected, you must remove the cover from the frame to prevent damage.

Step 1

Measure out at least 36in from each leg. Screw each anchor into the ground leaving 2in between the ground and the eye of each anchor. We strongly recommend that your unit be anchored 36in from each leg although this may not be possible in all cases. **DO** install anchors as close to 36in away from legs as possible.

Step 2

Tie anchor cable or rope around the connector at the top of each leg of the canopy.

Step 3

Securely tie the other end of the cable or rope through the eye of the anchor and pull tight.

Step 4

Now, continue to screw each anchor into the ground until the eye of the anchor is flush with the ground. This will secure the anchor rope even tighter.

NOTE: You should check and tighten the rope frequently to ensure maximum stability of your canopy and to protect against wind damage.

**ANCHOR KIT NOT INCLUDED
WITH THIS CANOPY**

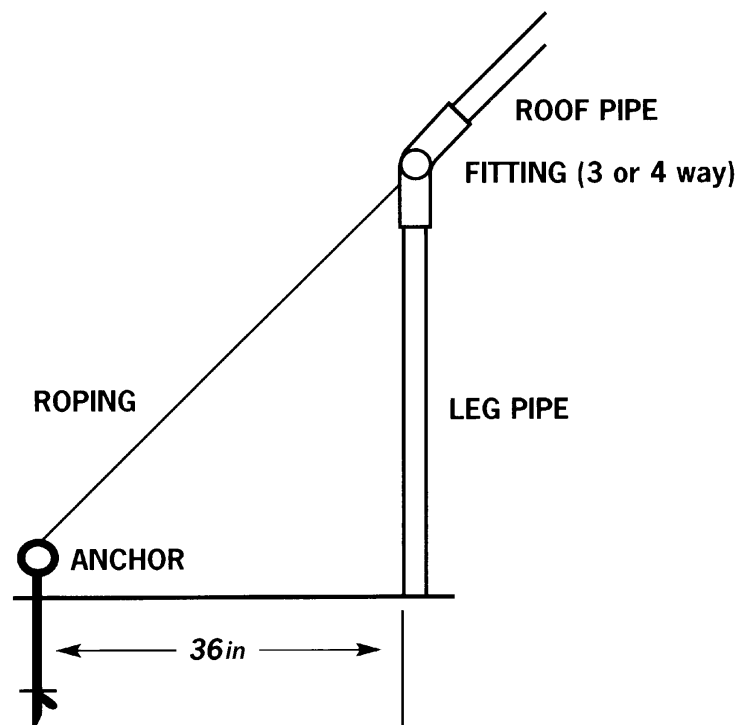

IMPORTANT NOTICE: PLEASE READ CAREFULLY



We are confident that you will be completely satisfied with your King Canopy unit. Please take a moment to read the very important information below, and call us with any questions you may have.

King Canopy/PIC America, LTD. has no control over wind, snow, ice, rain or any other weather condition and we are in no way responsible for any damage caused by the canopy or to the canopy. We suggest you contact your insurance carrier just as you would for any other outside structure.

OTHER PRECAUTIONS WHICH MUST BE FOLLOWED:

Keep all flame and heat sources away from this tent fabric. The tent fabric will burn if left in continuous contact with any flame source.

DO NOT cook underneath or near canopy.

DO NOT store or use flammable liquids underneath or near canopy.

DO NOT ignite or store fireworks underneath or near canopy.

DO NOT use bleach to clean cover.

DO NOT dry clean cover.

DO NOT wash cover in washing machine or dry in dryer. Hand wash with mild soap and water only.

DO NOT allow rain water, snow or ice to accumulate on top of cover.

DO NOT hang or suspend anything from the frame, grommets, truss system or ball straps of the unit.

REMOVE canopy cover before a storm, or disassemble entire canopy unit if possible.

REMOVE rain water, snow and ice from canopy cover.

This is a temporary structure and is not recommended for use as a permanent structure.



PRODUCT INFORMATION

Defective Parts

We try our best to eliminate any defective parts that are shipped with our products. If, however, you should find a defective part, we will replace – free of charge – any part which is defective. You will need to provide proof of purchase showing date of purchase and provide us with detailed description of the defective component. Your replacement will be shipped by ground shipping, freight prepaid. Next day or express shipping will require freight collect and paid for by you, the consumer. Damages from improper anchoring, strong winds, snow, ice or rain are not considered defects.

Improper Anchoring, Strong Winds, Rain Snow, or Ice

King Canopy/PIC America, LTD. does not guarantee these canopies under strong weather conditions. These canopies are designed to protect against damages caused by sun, rain, tree sap, birds, etc. They are not designed to hold roof loads that accompany snow, ice or heavy rains. If your canopy is not anchored securely, it can be lifted by the wind and will fly away. If your canopy takes flight, we are not responsible for any replacement. If you know strong weather is predicted, remove the cover or take down the canopy unit completely. The cover is designed to be quickly and easily removed.

Warranty

All components of this canopy feature a 1-year limited warranty and are warranted to be free from defects in material and workmanship for a period of 1-year. You must complete and return the enclosed warranty card promptly after purchase. Please retain your proof of purchase receipt; you will be asked to provide this receipt in order to obtain warranty service.

Non-Warranty Replacement Parts

If after expiration of the warranty period, you require replacement parts please contact us at 1-800-800-6296. We stock replacement parts and make them available to you at discounted prices. Our customer service department will be pleased to assist you in any way possible.

Certain regions of the country are extremely hard on covers of any kind. Normal wear and tear is not covered under the warranty, and should be expected.

In order to receive a discounted or free replacement part, you may be asked to return the part, freight prepaid, to our warehouse for inspection before we will send a replacement. You must, in all cases, provide a copy of your receipt showing the date of purchase, model number and price.

For missing parts, replacement parts or any questions:

Please Call 8:00am – 5:00pm EST, Monday – Friday

1-800-800-6296 or 1-919-552-2977

Or you can fax us at: **1-919-552-5069**

Replacement parts and customer service is also available through our website.

Please visit us at **www.kingcanopy.com**