



**Heavy Duty Power Equipment**

## Owner's Manual

**This Manual Contains Important Safety Instructions for Gasoline Powered Pressure Washer Models: 2550psi, 2650psi, 2700psi, 3200psi, and 3600psi**

### Contents:

1. Warnings
2. Product Specifications
3. Component Identification
4. Assembly
5. Operating the Pressure Washer
6. Maintenance
7. Transporting and Storage
8. Troubleshooting
9. Warranty and Service



**IMPORTANT SAFETY INSTRUCTIONS: READ SAFETY WARNINGS AND OPERATING INSTRUCTIONS CAREFULLY, SAVE THESE INSTRUCTIONS.**



**DO NOT RETURN THIS PRESSURE WASHER TO THE RETAILER!**

**QUESTIONS? OR HELP**

**call 24 hrs / 7-days a week help-line: [1] 800-393-0668**

**OR GO TO**

**[www.DEKPowerUSA.com](http://www.DEKPowerUSA.com)**

DEK® is registered trademark of GXi International, LLC  
Clayton, NC 27520 USA

No part of this publication can be printed or copied without written permission.

Have the following information ready when you call us:

Date of Purchase: \_\_\_\_\_

Location of Purchase: \_\_\_\_\_

Serial #: \_\_\_\_\_

This owner's manual is considered a permanent part of the pressure washer and should remain with the pressure washer if resold. The information and specifications included in this publication were in effect at the time of approval for printing.

GXi International, LLC, exclusive marketer of DEK Heavy Duty Power Equipment, reserves the right to discontinue or change specifications or design at any time without notice and without incurring any obligation whatever. No part of this publication may be reproduced without written permission.

**EMISSION CONTROL SYSTEM INFORMATION**

The U.S. and California Clean Air Acts

EPA and California regulations require all manufacturers to furnish written instructions describing the operation and maintenance of emission control systems. The following instructions and procedures must be followed in order to keep the emissions from your DEK engine within the emission standards.

**SAFETY LABEL LOCATIONS**

These labels warn you of potential hazards that can cause serious injury. Read them carefully. If a label comes off or becomes hard to read, contact your DEK pressure washer dealer for a replacement.

**SAFETY INFORMATION**

DEK pressure washers are designed to give safe and dependable service if operated according to instructions. Read and understand this owner's manual before operating your pressure washer.

**OPERATOR RESPONSIBILITY**

Know how to stop the pressure washer quickly in case of emergency. Understand the use of all product controls, output receptacles, and connections. Be sure that anyone who operates the pressure washer receives proper instruction. Do not let children operate the pressure washer without parental supervision.

 **WARNING**

**Running engine gives off carbon monoxide, an odorless, colorless, poison gas.**

**Breathing carbon monoxide can cause nausea, fainting or death.**

**Some chemicals or detergents may be harmful if inhaled or ingested, causing severe nausea, fainting or poisoning.**

- Operate pressure washer ONLY outdoors.
- Keep exhaust gas from entering a confined area through windows, doors, ventilation intakes or other openings.
- DO NOT operate pressure washer inside any building or enclosure, even if doors or windows are open.
- Use a respirator or mask whenever there is a chance that vapors may be inhaled.
- Read all instructions with mask so you are certain the mask will provide the necessary protection against inhaling harmful vapors.

 **WARNING**

**Fire and Burn Hazards**

- **The exhaust system gets hot enough to ignite some materials.**
- **Fuel and its vapors are extremely flammable and explosive.**
- **Fire or explosion can cause severe burns or death.**

**WHEN ADDING FUEL**

- Turn pressure washer OFF and let it cool at least 5 minutes before removing gas cap.
- Fill fuel tank outdoors with regular unleaded gas.
- DO NOT overfill tank. Allow space for fuel expansion.
- Keep fuel away from sparks, open flames, pilot lights, heat, and other ignition sources.
- DO NOT light a cigarette or smoke.

**WHEN OPERATING EQUIPMENT**

- DO NOT tip engine or equipment at angle which causes fuel to spill.
- DO NOT spray flammable liquids.

 **WARNING**

**The engine exhaust from this product contains chemicals known to the State of California to cause cancer, birth defects or other reproductive harm.**

 **WARNING**

**Use of pressure washer can create puddles and slippery surfaces.**

**High pressure spray could cause you to fall if you are too close to the cleaning surface.**

- Keep spray nozzle between 8 to 24 inches away from cleaning surface.
- Operate this unit on a stable surface.
- The cleaning area should have adequate slopes and drainage to reduce the possibility of a fall due to slippery surfaces.
- Be extremely careful if you must use the pressure washer from a ladder, scaffolding or any other relatively unstable location.
- Firmly grasp spray gun with both hands when using high pressure spray to avoid injury if gun kicks back.

 **WARNING**

**Rapid retraction of starter cord (kickback) will pull hand and arm toward engine faster than you can let go. Broken bones, fractures, bruises or sprains could result.**

- ALWAYS point gun in safe direction and squeeze spray gun trigger, to release pressure and avoid kickback each time, before starting engine. Engage trigger lock when not in use.
- When starting engine, pull cord slowly until resistance is felt and then pull rapidly to avoid kickback.
- After each starting attempt, where engine fails to run, always point gun in safe direction and squeeze spray gun trigger to release high pressure.

 **WARNING**

**Running engines produce heat. Temperature of muffler and nearby areas can reach or exceed 150°F (65°C).**

**Severe burns can occur on contact.**

**Exhaust heat/gases can ignite combustibles, structures or damage fuel tank causing a fire.**

- DO NOT touch hot surfaces and avoid hot exhaust gases.
- Allow equipment to cool before touching.
- Keep at least 5 ft. (152 cm) clearance on all sides of pressure washer including overhead.
- Code of Federal Regulation (CFR) Title 36 Parks, Forests, and Public Property require equipment powered by an internal combustion engine to have a spark arrester, maintained in effective working order, complying to USDA Forest service standard 5100-1C or later revision. In the State of California a spark arrester is required under section 4442 of the California Public resources code. Other states may have similar laws.

 **WARNING**

**Starter and other rotating parts can entangle hands, hair, clothing, or accessories.**

- DO NOT wear loose clothing, jewelry or anything that may be caught in the starter or other rotating parts.
- Tie up long hair and remove jewelry.

 **WARNING**

**High pressure spray can cause paint chips or other particles to become airborne.**

- Always wear eye protection when using this equipment or in vicinity of where equipment is in use.

 **WARNING**

**Unintentional sparking can result in fire or electric shock.**

**WHEN ADJUSTING OR MAKING REPAIRS TO YOUR PRESSURE WASHER**

- Disconnect spark plug wire from spark plug and place wire where it cannot contact spark plug.

**WHEN TESTING FOR ENGINE SPARK**

- Use approved spark plug tester.
- DO NOT check for spark with spark plug removed.

 **WARNING**

**The high pressure stream of water that this equipment produces can pierce skin and its underlying tissues, leading to serious injury and possible amputation.**

**Spray gun traps high water pressure, even when engine is stopped and water is disconnected, which can cause injury.**

- NEVER aim spray gun at people, animals or plants.
- DO NOT allow CHILDREN to operate pressure washer.
- NEVER repair high pressure hose. Replace it.
- NEVER repair leaking connections with sealant of any kind. Replace o-ring or seal.
- Keep high pressure hose connected to pump and spray gun while system is pressurized.
- ALWAYS point gun in safe direction and squeeze spray gun trigger, to release high pressure, every time you stop engine. Engage trigger lock when not in use.

 **CAUTION**

**Excessively high or low operating speeds increase risk of injury and damage to pressure washer.**

- DO NOT tamper with governed speed.
- DO NOT operate pressure washer above rated pressure.

 **CAUTION**

**A pressure washer produces a high pressure spray which increases risk of injury and damage to unit.**

- DO NOT secure spray gun in open position.
- DO NOT leave spray gun unattended while machine is running.
- NEVER use a spray gun which does not have a trigger lock or trigger guard in place and in working order.
- Always be certain spray gun, nozzles and accessories are correctly attached.

 **CAUTION**

**High pressure spray may damage fragile items including glass.**

- DO NOT point spray gun at glass when in jet spray mode.
- NEVER aim spray gun at plants.

 **CAUTION**

**Improper treatment of the pressure washer can damage it and shorten its life.**

- If you have questions about intended use, ask dealer or contact DEK Heavy Duty Power Equipment at [1] 800-393-0668.
- NEVER operate units with broken or missing parts, or without protective housing or covers.
- DO NOT by-pass any safety device on this machine.
- Before starting pressure washer in cold weather, check all parts of the equipment to be sure ice has not formed there.
- NEVER move machine by pulling on high pressure hose. Use handle provided on unit.
- Check fuel system for leaks or signs of deterioration, such as chafed or spongy hose, loose or missing clamps, or damaged tank or cap. Correct all defects before operating pressure washer.
- This equipment is designed to be used with DEK Heavy Duty Power Equipment's authorized parts **ONLY**. If equipment is used with parts that DO NOT comply with minimum specifications, user assumes all risks and liabilities.

**PRODUCT SPECIFICATIONS**

	Model				
	2550	2650	2700	3000	3600
Product Duty Rating	commercial	commercial	commercial	commercial	commercial
Rated Pressure (PSI)	2550	2650	2700	3000	3600
Rated Flow (GPM)	2.5	2.5	3.0	3.5	4.0
Pressure Valve Type	adjustable	adjustable	adjustable	adjustable	adjustable
Pump Type	axial	axial	triplex, plunger	triplex, plunger	triplex, plunger
Frame Pre-Treatment		galvanized	galvanized	galvanized	galvanized
Frame Covering		powder paint	powder paint	powder paint	powder paint
Wheels		Never-Go-Flat	Never-Go-Flat	Never-Go-Flat	Never-Go-Flat
High Pressure Hose	30 feet	30 feet	30 feet	30 feet	50 feet
Nozzles	5	5	5	5	5
Wand (4000 PSI rating)	yes	yes	yes	yes	yes
Soap Bottle Holder	no	yes	yes	yes	yes
Soap or detergent injector	yes	yes	yes	yes	yes
Folding Frame	yes	yes	yes	yes	yes
Engine	5.5 hp OHV	5.5 hp OHV	6.5 hp OHV	9.0 hp OHV	13.0 hp OHV
Max. Water Temperature Supply	100°F	100°F	100°F	100°F	100°F
Limited Warranty (commercial use/residential use)	1 yr./ 2 yr.	1 yr./ 2 yr.	1 yr./ 3 yr.	1 yr./ 3 yr.	1 yr./ 3 yr.
Fuel	Regular unleaded	Regular unleaded	Regular unleaded	Regular unleaded	Regular unleaded
Engine Oil	5W-30 (cold climate) or 10W-30	5W-30 (cold climate) or 10W-30	5W-30 (cold climate) or 10W-30	5W-30 (cold climate) or 10W-30	5W-30 (cold climate) or 10W-30
Pump Oil	High quality non-detergent 30 weight	High quality non-detergent 30 weight	High quality non-detergent 30 weight	High quality non-detergent 30 weight	High quality non-detergent 30 weight

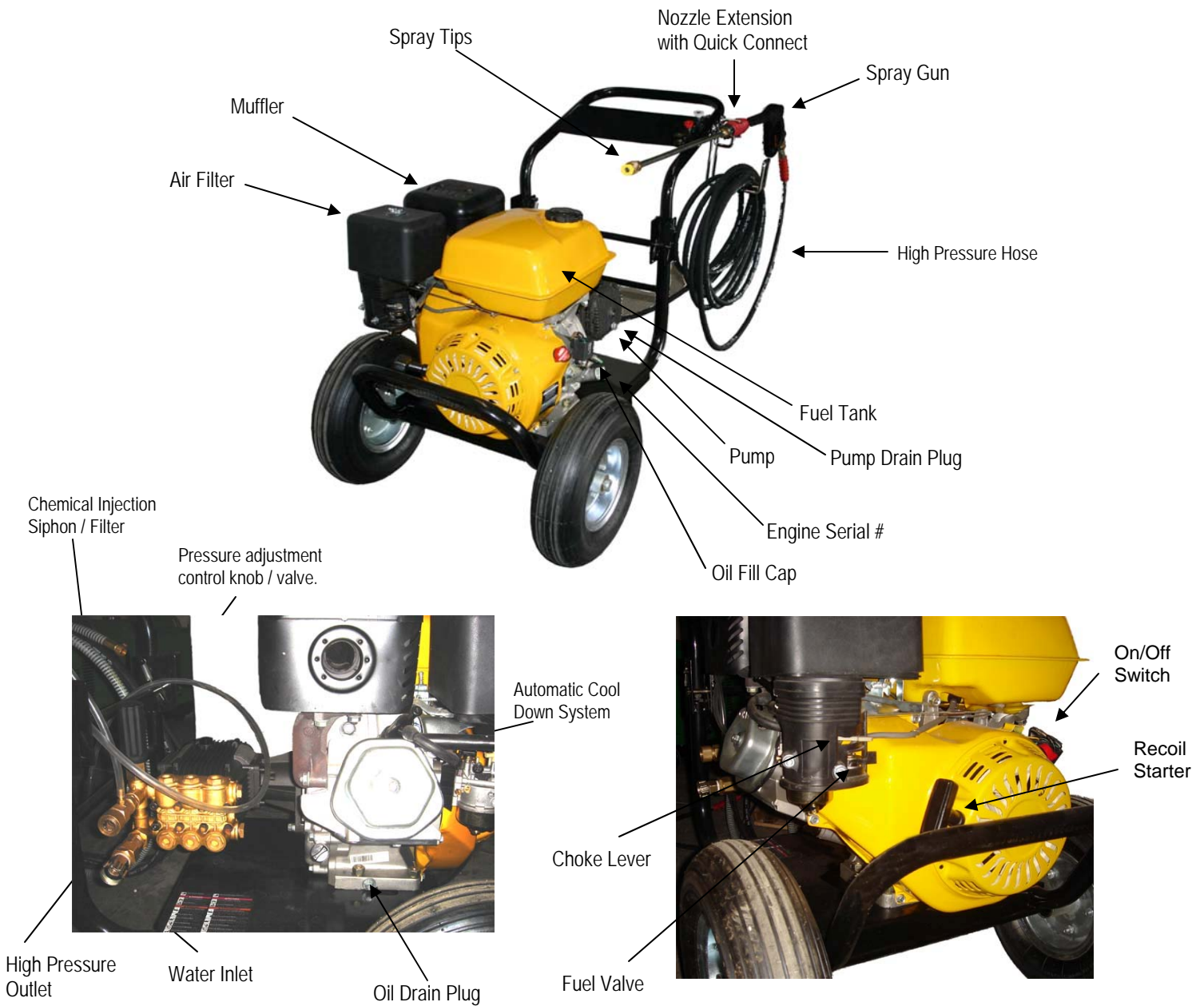

**Air Filter** — Protects engine by filtering dust and debris out of intake air.

**Automatic Cool Down System** — Cycles water through pump when water reaches 125°-155°F. Warm water will discharge from pump onto ground. This system prevents internal pump damage.

**Chemical Injection Siphon/Filter** — Use to siphon detergent or other pressure washer chemicals into the low pressure stream.

**Choke Lever** — Prepares a cold engine for starting.

**Engine Serial #** — serial number of pressure washer. Please have these readily available if calling for assistance.

**Fuel Tank** — Fill tank with regular unleaded fuel. Always leave room for fuel expansion.

**Fuel Valve** — Used to turn fuel on and off to engine.

**High Pressure Hose** — Connect one end to the water pump and the other end to the spray gun.

**High Pressure Outlet** — To connect high pressure hose.

**Muffler** — Reduces engine exhaust noise.

**Nozzle Extension with Quick Connect** — Allows you to switch between five different spray tips.

**Oil Drain Plug** — Drain oil from engine here.

**Oil Fill Cap** — Fill engine with oil here.

**On/Off Switch** — Set this switch to "On" before using recoil starter. Set switch to "Off" to switch off engine.

**Pump** — Develops high pressure.

**Pump Drain Plug** — Drain oil from pump here.

**Recoil Starter** — Use for starting the engine manually.

**Spray Gun** — Controls the application of water onto cleaning surface with trigger device. Includes safety latch.

**Spray Tips** — Chemical application tip, 0°, 15°, 25°, and 40°: for various high pressure cleaning applications.

**Water Inlet** — Connect garden hose here.

**ASSEMBLY**

**IMPORTANT:** Read entire operator's manual before you attempt to assemble or operate your new pressure washer.

**PREPARING PRESSURE WASHER FOR USE**

If you have any questions or require assistance with the assembly of your pressure washer or if parts are missing or damaged, call the pressure washer helpline at toll-free **1-800-393-0668** or direct [1] **919-550-3260**.

**To prepare your pressure washer for operation, you will need to perform these tasks:**

1. Fill out and send in the registration card.
2. Replace the pump shipping plug with the oil dipstick on the high pressure pump (Figure 1). **NOTE: THIS APPLIES TO MODELS: 2700PSI, 3200SI, 3600PSI**
3. Attach the wheels (Figure 2).
4. Attach the rubber feet (Figure 3).
5. Flip the handle bar up into the top position. To release the handle, press down on the spring loaded locking bar. (Figure 6).
6. Attach the hose bracket (Figure 4).
7. Attach the soap bottle bracket (Figure 5).
8. Add oil to engine. Requires between 0.8 quarts and 1.1 quarts of oil depending on the engine. **The engine has a low oil sensor and will not work unless the engine is COMPLETELY full to the top of the filler spout.**
9. Add fuel to fuel tank.
10. Connect high pressure hose to spray gun and pump.
11. Connect water supply to pump.
12. Connect nozzle extension to spray gun.
13. Select/attach quick connect spray tip to nozzle exten-

**Figure 1 — Pump Oil Dipstick**



Replace the oil shipping plug with the vented pump oil dipstick.

**Failure to replace the shipping plug may damage the pump.**

Pump comes pre-filled with pump oil. Verify the oil level is aligned with the sight glass on models: 2700psi - 3600psi or filled half-way on the 2550psi—2650psi models.



**Figure 2 — Attach wheels**

Insert the axle bolt through the axle bracket and tighten the nuts securely on each end of the axle bolt.



**Figure 3 — Attach rubber pads**

Insert the rubber pad bolt through the hole on the feet. Tighten the retainer nut securely.



**Figure 4 — Attach hose bracket**

Locate the hose bracket on the handle bar and insert the retaining bolts through the hole. Tighten the retaining nuts securely.



**Figure 5 — Attach soap bracket**

Connect the soap bottle bracket by inserting the prongs through the holes on the pressure washer deck.

**Figure 6 — Flip handle bar up.**

Push the spring loaded bar to unlock the handle bar.



**Add Engine Oil and Fuel**

- Place pressure washer on a level surface.

**CAUTION**

Any attempt to crank or start the engine before it has been properly filled with the recommended oil will result in equipment failure.

- Damage to equipment resulting from failure to follow this instruction will void warranty.

**Connect Hose and Water Supply to Pump**

**IMPORTANT:** To avoid pump damage, you must assemble the nozzle extension to the spray gun and attach all hoses before you start the engine.

1. Uncoil high pressure hose and attach quick connect end of hose to base of spray gun (Figure 4). Pull down on collar of quick connect, slide onto spray gun and let go of collar. Tug on hose to be sure of a tight connection.
2. Similarly, attach other end of high pressure hose to the high pressure outlet on pump. Pull down on collar of quick connect, slide onto pump and let go of collar. Pull on hose to be sure of a tight connection.
3. Before connecting garden hose to water inlet, inspect inlet screen (Figure 5). Clean screen if it contains debris or replace if damaged. Refer to the section "O-Ring Maintenance" if inlet screen is damaged. DO NOT run pressure washer if inlet screen is damaged.
4. Run water through garden hose for 30 seconds to clean out any debris. Turn off water.
5. Connect garden hose (not to exceed 50 feet in length) to water inlet. Tighten by hand (Figure 5).
6. Turn ON water and squeeze trigger on spray gun to purge pump system of air and debris.

**Figure 4 — Connect High Pressure Hose to Spray**

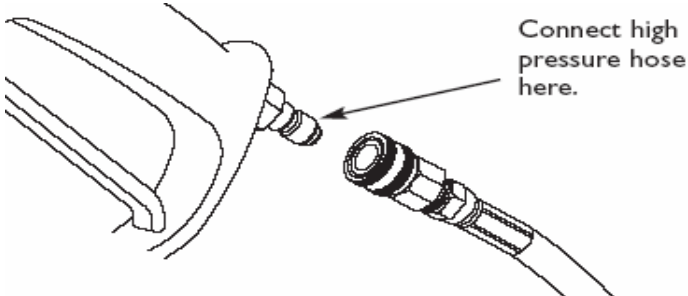

**NOTE:** Remove and discard all pump shipping caps before attaching hoses.

**IMPORTANT:** DO NOT siphon standing water for the water supply. Use ONLY cold water (less than 100°F).

**Figure 5 — Connect Garden Hose to Water Inlet**

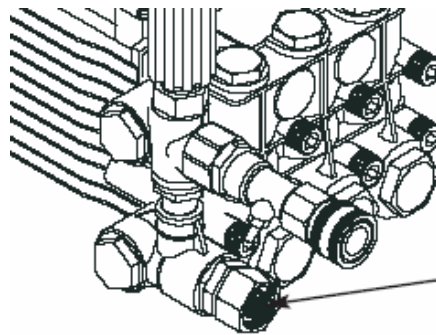

Inspect inlet screen. DO NOT use if damaged; clean if dirty.

**CAUTION**

There **MUST** be at least ten feet of unrestricted garden hose between the pressure washer inlet and any flow shut off device, such as a 'Y' shut-off connector or other convenience-type water shut-off valve.

- Damage to equipment resulting from failure to follow this instruction will void warranty.

**WARNING**

High pressure spray can cause paint chips or other particles to become airborne.

- Always wear eye protection when using this equipment or in vicinity of where equipment is in use.
- Before starting the pressure washer, be sure you are wearing adequate eye protection.

**Checklist Before Starting the Engine**

Review the unit's assembly to confirm you have performed all of the following:

1. Make sure handle is secure.
2. Make sure oil dipstick is installed into pump.
3. Check to make sure the pump is filled with oil.
4. Check for properly tightened hose connections.
5. Check to make sure there are no kinks, cuts, or damage to high pressure hose.
6. Check that oil has been added to proper level in engine crankcase.
7. Add proper fuel to fuel tank.
8. Provide a proper water supply (not to exceed 100°F).
9. Be sure to read "Warnings" and the entire owner's manual before using pressure washer.
10. Turn the adjustable pressure knob clockwise to reduce the initial pressure when the pump is started. This can be re-adjusted to desired pressure level for the application once the pump is operating.

## HOW TO USE THE PRESSURE WASHER

If you have any problems operating your pressure washer, please call the pressure washer helpline at **1-800-393-0668**.

### Pressure Washer Clearance



**WARNING**

Exhaust heat/gases can ignite combustibles, structures or damage fuel tank causing a fire.

- Keep at least 5 ft. (152 cm) clearance on all sides of pressure washer including overhead.

Place pressure washer in a well ventilated area, which will allow for removal of deadly exhaust gas. **DO NOT** place pressure washer where exhaust gas could accumulate and enter inside or be drawn into a potentially occupied building. Ensure exhaust gas is kept away from any windows, doors, ventilation intakes or other openings that can allow exhaust gas to collect in a confined area (Figure 6). Prevailing winds and air currents should be taken into consideration when positioning pressure washer.



**WARNING**

Running engine gives off carbon monoxide, an odorless, colorless, poison gas.

Breathing carbon monoxide can cause nausea, fainting or death.

- Operate pressure washer **ONLY** outdoors.
- Keep exhaust gas from entering a confined area through windows, doors, ventilation intakes or other openings.
- **DO NOT** operate pressure washer inside any building or enclosure, even if doors or windows are open.

**Figure 6 — Pressure Washer Clearance**

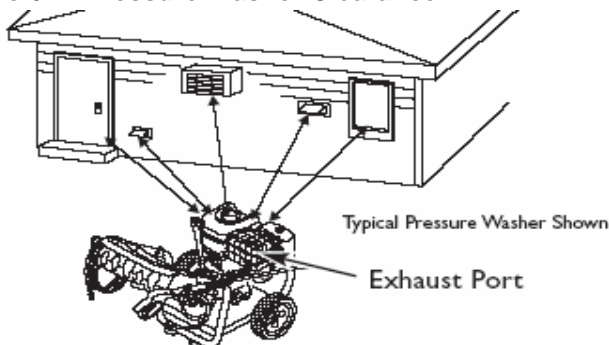

### To Start Engine:

The best way to start your pressure washer for the first time is to follow these instructions step-by-step. This starting information also applies if you have let the pressure washer sit idle for at least a day.

1. Place pressure washer near an outside water source capable of supplying water at a flow rate greater than 4.2 gallons per minute and no less than 20 PSI at pressure washer end of garden hose.
2. Check that the high pressure hose is tightly connected to spray gun and pump. See "Preparing Pressure Washer for Use" for illustrations.
3. Make sure unit is in level position.
4. Connect garden hose to water inlet on pressure washer pump. **TURN ON WATER.**
5. Squeeze spray gun trigger until a steady stream of water occurs.
6. Attach nozzle extension to spray gun (Figure 7). Tighten by hand.
7. Select desired quick connect spray tip and insert it into end of nozzle extension (see "Operation" to select correct spray tip).



**CAUTION**

**DO NOT** run the pump without the water supply connected and turned on.

- Damage to equipment resulting from failure to follow this instruction will void warranty.

**Figure 7 — Connect Nozzle Extension to Spray Gun**



**Figure 8 — Spray Gun with Trigger Lock Engaged**

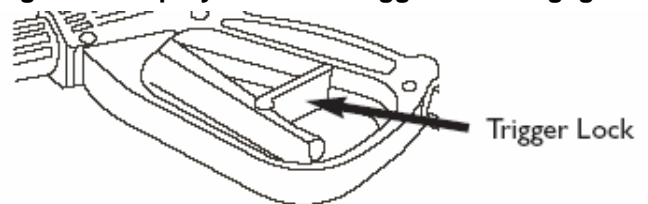

When starting engine, position yourself as recommended in Figure 9 and start engine according to instructions posted on the engine.

**NOTE:** Do not adjust the throttle speed of the engine. This speed is set at 3600 RPM by the factory.

**Figure 9 - Recommended Starting**

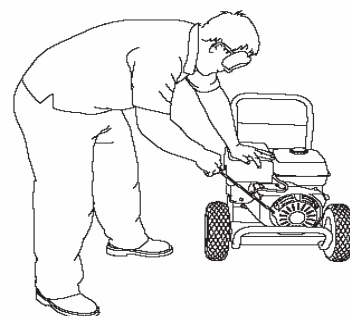



 **WARNING**

**Rapid retraction of starter cord (kickback) will pull hand and arm toward engine faster than you can let go. Broken bones, fractures, bruises or sprains could result.**

- ALWAYS point gun in safe direction and squeeze spray gun trigger, to release pressure and avoid kickback each time, before starting engine.
- When starting engine, pull cord slowly until resistance is felt and then pull rapidly to avoid kickback.
- After each starting attempt, where engine fails to run, always point gun in safe direction and squeeze spray gun trigger to release high pressure.

 **WARNING**

**Running engines produce heat. Temperature of muffler and nearby areas can reach or exceed 150°F(65°C).**

**Severe burns can occur on contact.**

**Exhaust heat/gases can ignite combustibles, structures or damage fuel tank causing a fire.**

- DO NOT touch hot surfaces and avoid hot exhaust gases.
- Allow equipment to cool before touching.
- Keep at least 5 ft. (152 cm) clearance on all sides of pressure washer including overhead.
- Code of Federal Regulation (CFR) Title 36 Parks, Forests, and Public Property require equipment powered by an internal combustion engine to have a spark arrester, maintained in effective working order, complying to USDA Forest service standard 5100-1C or later revision. In the State of California a spark arrester is required under section 4442 of the California Public resources code. Other states may have similar laws.

**How to Stop Pressure Washer**

1. Let engine idle for two minutes.
2. Turn engine off according to instructions posted on the engine.
3. ALWAYS point gun in a safe direction and squeeze spray gun trigger to release retained high water pressure.
4. Engage trigger lock on spray gun when not in use.

**How to Use Spray Tips**

The nozzle extension quick-connect allows the use of several different spray tips. Each spray tip provides a different spray pattern (Figure 10).

 **CAUTION**

**A pressure washer produces a high pressure spray which increases risk of injury and damage to unit.**

- Always wear eye protection when using this equipment or in vicinity of where equipment is in use.
- NEVER exchange spray tips without locking the trigger lock on the spray gun.

 **WARNING**

**The high pressure stream of water that this equipment produces can pierce skin and its underlying tissues, leading to serious injury and possible amputation.**

**Spray gun traps high water pressure, even when engine is stopped and water is disconnected, which can cause injury.**

- Keep high pressure hose connected to pump and spray gun while system is pressurized.
- ALWAYS point gun in safe direction and squeeze spray gun trigger, to release high pressure, every time you stop engine. Engage trigger lock when not in use.

**Follow these instructions to change spray tips:**

1. Engage trigger lock on spray gun.
2. Pull back collar on quick-connect and pull current spray tip off.
3. Select desired spray tip:
  - For gentle rinse, select white 40° or green 25° spray tip.
  - To scour surface, select yellow 15° or red 0° spray tip.
  - To apply chemical, select black spray tip.
4. Pull back on collar, insert new spray tip and release collar. Tug on spray tip to make sure it is securely in place.
5. For most effective cleaning, keep spray tip from 8 to 24 inches away from cleaning surface.
6. DO NOT get closer than 6 inches when cleaning automobile tires.

**Cleaning and Applying Chemical**

**IMPORTANT: Use detergents designed specifically for pressure washers.** Household detergents could damage the pump.

 **CAUTION**

**You must attach all hoses before you start the engine.**

- Starting the engine without all the hoses connected and without the water turned ON will damage the pump.
- Damage to equipment resulting from failure to follow this instruction will void warranty.

**To apply detergent follow these steps:**

1. Review spray tip use.
2. Prepare detergent solution as required by manufacturer.
3. Place chemical injection siphon/filter into detergent container.
4. Make sure black spray tip is installed.

**NOTE:** Detergent cannot be applied with high pressure spray tips (White, Green, Yellow, or Red).

**CAUTION**

Keep the chemical injection tube from coming in contact with the hot muffler.

- When inserting the filter into a detergent solution bottle, route the tube so as to keep it from inadvertently contacting the hot muffler.
5. Make sure garden hose is connected to water inlet. Check that high pressure hose is connected to spray gun and pump; start engine.
  6. Apply detergent to a dry surface, starting at lower portion of area to be washed and work upward, using long, even, overlapping strokes. DO NOT allow detergent to dry on (prevents streaking).
  7. Allow detergent to soak in between 3–5 minutes before washing and rinsing. Reapply as needed to prevent surface from drying.

**Pressure Washer Rinsing**

After you have applied detergent, scour the surface and rinse it clean as follows:

1. Apply trigger lock to spray gun.
2. Remove black chemical spray tip from nozzle extension.
3. Select and install desired high pressure spray tip following the instructions in "How to Use Spray Tips".
4. Keep spray gun a safe distance from the area you plan to spray.

**WARNING**

High pressure spray could cause you to fall if you are too close to the cleaning surface.

- Keep spray nozzle between 8 to 24 inches away from cleaning surface.
- Operate this unit on a stable surface.
- Be extremely careful if you must use the pressure washer from a ladder, scaffolding or any other relatively unstable location.
- Firmly grasp spray gun with both hands when using high pressure spray to avoid injury if gun kicks back.

5. Increase or decrease spray pressure by turning pressure control knob counterclockwise or clockwise respectively (Figure 11). Use lower pressure to wash items such as a car or boat. Use higher pressure to strip paint and degrease driveways.
6. Apply high pressure spray to small area and then check surface for damage. If no damage is found, you can assume it is okay to continue cleaning.
7. Start at top of area to be rinsed, working down with same overlapping strokes as used for cleaning.

**Figure 11 — Pressure Control Knob**

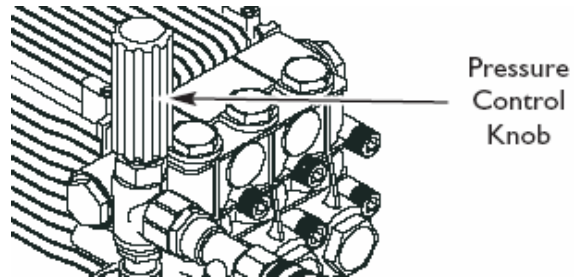

**Cleaning Detergent Siphoning Tube**

If you used the detergent siphoning tube, you must flush it with clean water before stopping the engine.

1. Place chemical injection siphon/filter in a bucket full of clean water.
2. Attach black low pressure spray tip.
3. Flush for 1-2 minutes.
4. Shut off engine.

**IMPORTANT:** Simply shutting OFF engine will not release pressure in the system. When the engine has shut down, squeeze the trigger on the spray gun to relieve the pressure in the hose.

**Automatic Cool Down System (Thermal Relief)**

If you run the engine on your pressure washer for 3-5 minutes without pressing the trigger on the spray gun, circulating water in the pump can reach temperatures above 125°F. The system engages to cool the pump by discharging the warm water onto the ground.

**Figure 10 — Spray Tips**

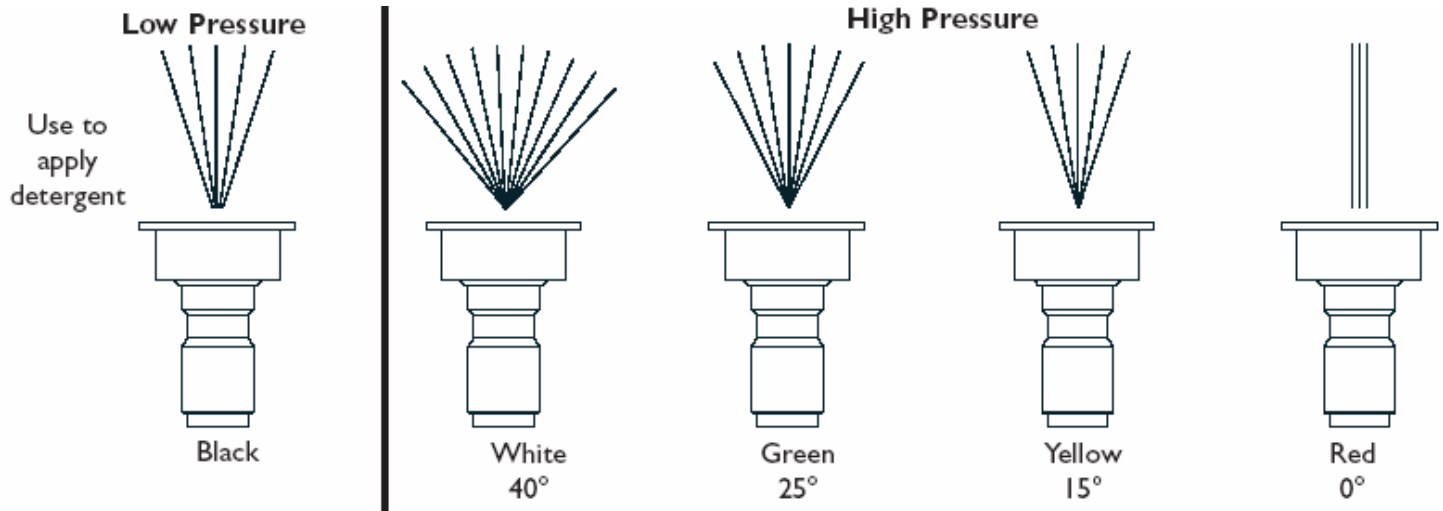

**GENERAL MAINTENANCE RECOMMENDATIONS**

The pressure washer warranty does not cover items that have been subjected to operator abuse or negligence. To receive full value from the warranty, the operator must maintain the pressure washer as instructed in this manual.

**NOTE:** Should you have questions about replacing components on your pressure washer, please call **1-800-393-0668** for assistance.

- Some adjustments will need to be made periodically to properly maintain your high pressure washer.
- All maintenance in this manual and the engine operator’s manual should be made at least once each season.
- If equipped with inflatable tires, keep the air pressure at the value marked on the tire or within 15 and 40 psi.

**Before Each Use**

1. Check engine oil level.
2. Check pump oil level through site glass.
3. Check water inlet screen for damage.
4. Check in-line filter for damage.
5. Check high pressure hose for leaks.
6. Check detergent siphoning tube and filter for damage.
7. Check spray gun, nozzle extension, and nozzles for leaks.
8. Rinse out garden hose to flush out debris.

**PRESSURE WASHER MAINTENANCE**

**Check and Clean Inlet Screen**

Examine the screen on the water inlet. Clean it if the screen is clogged or replace it if screen is damaged.

**Check High Pressure Hose**

The high pressure hose can develop leaks from wear, kinking, or abuse. Inspect the hose each time before using it. Check for cuts, leaks, abrasions or bulging of cover, damage or movement of couplings. If any of these conditions exist, replace the hose immediately.



**WARNING**

**The high pressure stream of water that this equipment produces can pierce skin and its underlying tissues, leading to serious injury and possible amputation.**

- NEVER repair high pressure hose. Replace it.
- Replacement hose rating MUST exceed maximum pressure rating of unit.

**Check Detergent Siphoning Tube**

Examine the filter on the detergent tube and clean if clogged. The tube should fit tightly on the barbed fitting. Examine the tube for leaks or tears. Replace the filter or tube if either is damaged.

**Check Gun and Nozzle Extension**

Examine the hose connection to the spray gun and make sure it is secure. Test the trigger by pressing it and making sure it springs back into place when you release it. Put the trigger lock in the on position and test the trigger. You should not be able to press the trigger.

**Check In-Line Filter**

Refer to Figure 12 and service the in-line filter if it becomes clogged, as follows:

**Figure 12 — Clean In-Line Filter**

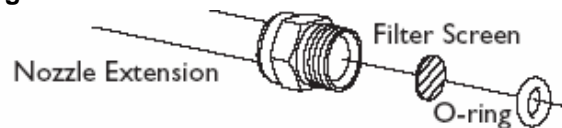

1. Detach spray gun and nozzle extension from high pressure hose. Detach nozzle extension from spray gun and remove o-ring and screen from nozzle extension. Flush the screen, spray gun, and adjustable nozzle extension with clean water to clear debris.
2. If screen is damaged, the o-ring kit contains a replacement in-line filter screen and o-ring. If undamaged, reuse screen.
3. Place in-line filter screen into threaded end of nozzle extension. Direction does not matter. Push screen in with eraser end of pencil until it rests flat at bottom of opening. Take care to not bend screen.
4. Place o-ring into recess. Push o-ring snugly against in-line filter screen.
5. Assemble nozzle extension to spray gun, as described earlier in this manual.

**Nozzle Maintenance**

A pulsing sensation felt while squeezing the spray gun trigger may be caused by excessive pump pressure. The principal cause of excessive pump pressure is a nozzle clogged or restricted with foreign materials, such as dirt, etc. To correct the problem, immediately clean the nozzle using the tools included with your pressure washer and follow these instructions:

1. Shut off engine and turn off water supply.
2. Remove spray tip from end of nozzle extension.
3. Remove in-line filter from other end of nozzle extension.
4. Use wire included in kit (or a small paper clip) to free any foreign material clogging or restricting spray tip (Figure 13).

**Figure 13 — Nozzle Maintenance**



5. Using a garden hose, remove additional debris by back flushing water through nozzle extension (Figure 14). Back flush between 30 to 60 seconds.

Figure 14 — Back flushing the Nozzle Extension

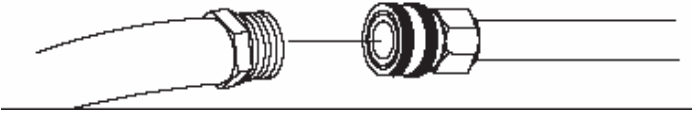

6. Reinstall spray tip and in-line filter into nozzle extension.
7. Reconnect nozzle extension to spray gun.
8. Reconnect water supply, turn on water, and start engine.
9. Test pressure washer by operating with each quick connect spray tip.

**O-Ring Maintenance**

Through the normal operation of your pressure washer, o-rings, which keep the connections of the hoses and spray gun tight and leak-free, may become worn or damaged.

An O-Ring Maintenance Kit is provided with your pressure washer which includes replacement o-rings, rubber washer and water inlet filter. Refer to the instruction sheet provided in the kit to service your unit's o-rings. Note that not all of the parts in the kit will be used on your unit.



**WARNING**

The high pressure stream of water that this equipment produces can pierce skin and its underlying tissues, leading to serious injury and possible amputation.

- NEVER repair leaking connections with sealant of any kind. Replace o-ring or seal.

To remove a worn or damaged o-ring; use a small flat-head screwdriver to get underneath the o-ring and pry it off.

**Pump Maintenance**

**Changing Pump Oil**

Change oil after first 20 hours of operation and then every 20 hours or 3 months, whichever occurs first. **NOTE:** When changing pump oil, use only high quality non-detergent 30 weight. Use no special additives.

**Change pump oil as follows:**

1. Clean area around brass oil drain plug at bottom of pump.
2. Remove oil drain plug. Drain oil completely into an approved container.
3. When oil has completely drained, install oil drain plug and tighten firmly.
4. Clean area around pump oil dipstick. Remove dipstick and fill pump with recommended oil to "Full" mark on dipstick. Visually check to ensure that there is approximately a 1" air gap between the top of the oil level and the top of the pump fill.
5. Install pump oil dipstick.
6. Wipe up any spilled oil.



**CAUTION**

Avoid prolonged or repeated skin contact with used motor oil.

- Used motor oil has been shown to cause skin cancer in certain laboratory animals.
- Thoroughly wash exposed areas with soap and water.

**Maintenance Schedule**

Item	Before each use	20hrs or every 3 month	50 hrs or every 3 months	100 hrs or every 6 months	300 hrs or every 1 year
Engine oil (Check)	X				
Engine Oil (Change)		X			
Air Cleaner (Check)	X				
Air Cleaner Wash			X		
Fuel filter Cup (Clean)				X	
Spark Plug (Clean)				X	
Spark Plug (Change)					X
Pump Oil		X			
Valve Clearance (Clean)					X*
Fuel Tank and Filter (Clean)				X*	
Fuel Tube (Check)					
Combustion Chamber (Clean)					

**Engine Maintenance**

**Changing Engine Oil**

Change oil after first 20 hours of operation and then every 20 hours or 3 months, whichever occurs first. **NOTE:** When changing engine oil, use only high quality SAE 10W-30. Use no special additives.

**Change pump oil as follows:**

1. Remove oil drain plug. Drain oil completely into an approved container.
2. When oil has completely drained, install oil drain plug and tighten firmly.
3. Fill engine with oil to the top of the filler spout.
4. Install filler spout plug.
5. Wipe up any spilled oil.



**KEEP OUT OF REACH OF CHILDREN. DON'T POLLUTE. CONSERVE RESOURCES. RETURN USED OIL TO COLLECTION CENTERS.**

 **CAUTION**

You must protect your unit from freezing temperatures.

- Failure to do so will permanently damage your pump and render your unit inoperable.
- Freeze damage is not covered under warranty.

 **CAUTION**

When storing fuel or equipment with fuel in the tank:

- Store away from furnaces, stoves, water heaters, or other appliances that have a pilot light or other ignition source because they can ignite vapors.

 **CAUTION**

When transporting equipment:

- Transport with fuel tank EMPTY or with fuel shut-off valve in the OFF position.

**STORING**

Before storing the unit for an extended period:

1. Be sure the storage area is free of excessive humidity and dust.
2. Service according to the table below:

STORAGE TIME	Recommended Service Procedure to prevent hard starting:
1 to 2 months	Fill with fresh gasoline and add gasoline conditioner*.
2 months to 1 year	Fill with fresh gasoline and add gasoline conditioner*. Drain the carburetor float bowl.
1 year or longer	Fill with fresh gasoline and add gasoline conditioner*. Drain the carburetor float bowl. Remove the spark plug. Put a tablespoon of engine oil into the cylinder. Turn the engine slowly with the recoil starter to distribute the oil. Reinstall the spark plug. Change the engine oil. After removal from storage, drain the stored gasoline into a suitable container, and fill with fresh gasoline before starting.
* Use gasoline conditioners that are formulated to extend storage life. Contact your authorized DEK generator dealer for conditioner recommendations.	

**Storage Preparation for Pressure Washer Engine**

1. Drain the carburetor by loosening the drain screw. Drain the gasoline into a suitable container. Place 4 ounces of fuel stabilizer in the fuel tank.
2. While the engine is warm, change the engine oil.
3. Remove the spark plug, and pour about a tablespoon of clean engine oil into the cylinder. Turn the engine several revolutions slowly with the recoil starter to distribute the oil, then reinstall the spark plug.
4. Slowly pull the starter grip until resistance is felt. At this point, the piston is coming up on its compression stroke and both the intake and exhaust valves are closed. Storing the engine in this position will help to protect it from internal corrosion.

**Storage Preparation for Pressure Pump**

Water should not remain in the unit for long periods of time. Sediments or minerals can deposit on pump parts and “freeze” pump action. If you do not plan to use the pressure washer for more than 30 days, follow this procedure:

1. Flush chemical injection hose by placing filter into a pail of clean water while running pressure washer in low pressure mode. Flush for one to two minutes.
2. Shut off engine and let it cool, then remove high pressure and garden hoses. Disconnect spark plug wire from spark plug.
3. Empty pump of liquids by pulling engine recoil handle about 6 times. This should remove most liquid from pump.
4. Ensure pump is clean and empty to prevent corrosion build up and freezing of pump components.
5. Store unit in a clean, dry area.

<b>Problem</b>	<b>Cause</b>	<b>Correction</b>
<b>Pump has following problems: failure to produce pressure, erratic pressure, chattering, loss of pressure, low water volume.</b>	1. Low pressure spray tip installed.	1. Replace spray tip with high pressure spray tip.
	2. Water inlet is blocked.	2. Clear inlet.
	3. Inadequate water supply.	3. Provide adequate water flow.
	4. Inlet hose is kinked or leaking.	4. Straighten inlet hose, patch leak.
	5. Clogged inlet hose strainer.	5. Check and clean inlet hose strainer
	6. Water supply is over 100°F.	6. Provide cooler water supply.
	7. High pressure hose is blocked or leaks	7. Clear blocks in outlet hose.
	8. Gun leaks.	8. Replace gun.
	9. Spray tip is obstructed.	9. Clean spray tip.
	10. Pump is faulty.	10. Contact authorized service facility.
<b>Detergent fails to mix with spray.</b>	1. Detergent siphoning tube is not submerged.	1. Insert detergent siphoning tube into detergent.
	2. Chemical filter is clogged or cracked.	2. Clean or replace filter/detergent siphoning tube.
	3. Dirty in-line filter.	3. See "Check In-Line Filter".
	4. High pressure spray tip installed.	4. Replace spray tip with low pressure spray tip.
<b>Engine shuts down during operation</b>	1. Out of gasoline.	1. Fill fuel tank.
	2. Low engine oil	2. Fill engine with oil.
<b>Engine is running rough or is smoking.</b>	1. Engine may have been tipped during transport.	1. Spark plug may be fouled. Replace spark plug.
	2. Air cleaner is dirty.	2. Clean or replace air cleaner.

PRODUCTS COVERED BY THIS WARRANTY:	LENGTH OF WARRANTY:* (FROM THE DATE OF ORIGINAL RETAIL PURCHASE)		
	NONCOMMERCIAL/ NON-RENTAL	COMMERCIAL	RENTAL
Engine	24 months	12 months	12 months
Centrifugal Pump and Frame Components	24 months	3 months	3 months
Diaphragm Pump and Frame Components	12 months	12 months	12 months
Generator Engine and Alternator	24 months	12 months	12 months
Generator Electrical and Frame Components	24 months	12 months	12 months

\*LENGTH OF WARRANTY: Batteries supplied with applicable products as standard, original equipment are covered by this warranty for a period of 12 months (noncommercial use) or 3 months (commercial/rental use) from the date of original retail product purchase. Consumable parts such as oil, spark plugs, filters are not covered by this warranty.

**TO QUALIFY FOR THIS WARRANTY:**

The product must be purchased in the United States from a dealer authorized by GXi International, LLC to sell those products. This warranty applies to first retail purchaser / owner during the applicable warranty time period. NO WARRANTY REGISTRATION IS NECESSARY TO OBTAIN WARRANTY ON DEK PRODUCTS. SAVE YOUR PROOF OF PURCHASE RECEIPT. IF YOU DO NOT PROVIDE PROOF OF THE INITIAL PURCHASE DATE AT THE TIME WARRANTY SERVICE IS REQUESTED, THE MANUFACTURING DATE OF THE PRODUCT WILL BE USED TO DETERMINE THE WARRANTY PERIOD.

**WHAT DEK POWER EQUIPMENT WILL REPAIR OR REPLACE UNDER WARRANTY:**

DEK will repair or replace, at its option, any part that is proven to be **defective in material or workmanship** under normal use during the applicable warranty time period subject to the exclusions stated herein. This warranty is void if the owner fails to follow the prescribed maintenance and operating procedures described in this manual. This specifically refers to ensuring routine oil changes are made, that fuel stabilizer is used for long-term storage, that the generator is not overloaded, and that the generator loads are distributed evenly between the A and B outlets.

DEK has the right to recover warranty administration costs from the owner if the root cause of the malfunction was found to be other than defective material or workmanship. In particular, this warranty does not cover: contaminants in the fuel or oil; damage caused by not following the prescribed warnings and operating practices; failure to follow proper maintenance and storage procedures; and physical damage due to shipping or handling or storage. Damage to the generator that occurs as a result of connecting a DEK generator to household wiring without the use of a UL approved transfer switch device that is connected to the home or business and grounded as per applicable local electrical codes, is not covered by this warranty.

Warranty repairs will be made without charge for parts and labor for the first year. After the first year, this limited warranty covers the costs of replacement parts only.

Anything replaced under warranty becomes the property of DEK. Parts replaced under warranty will be considered as part of the original product and any warranty on those parts will expire coincident with the original product warranty.

**TO OBTAIN WARRANTY SERVICE:**

You must take the DEK Power Equipment product, accessory, replacement part, apparel or the power equipment on which the accessory or replacement part is installed, and proof of purchase, at your expense, to any DEK Power Equipment service location in the United States, who is authorized to service that product, during the service location's normal business hours. If you are unable to obtain warranty service, or are dissatisfied with the warranty service you receive, take the following steps: First, contact the manager of the service center involved; normally this will resolve the problem. However, if you should require further assistance, write or call the DEK Customer Service.

**EXCLUSIONS:**

THIS WARRANTY DOES NOT EXTEND TO PARTS AFFECTED OR DAMAGED BY ACCIDENT AND/OR COLLISION, NORMAL WEAR, FUEL CONTAMINATION, USE IN AN APPLICATION FOR WHICH THE PRODUCT WAS NOT DESIGNED OR ANY OTHER MISUSE, NEGLIGENCE, INCORPORATION OR USE OF UNSUITABLE ATTACHMENTS OR PARTS, UNAUTHORIZED ALTERATION, OR ANY CAUSES OTHER THAN DEFECTS IN MATERIAL OR WORKMANSHIP OF THE PRODUCT.

**DISCLAIMER OF CONSEQUENTIAL DAMAGE AND LIMITATION OF IMPLIED WARRANTIES:**

DEK DISCLAIMS ANY RESPONSIBILITY FOR LOSS OF TIME OR USE OF THE PRODUCT, TRANSPORTATION, COMMERCIAL LOSS, OR ANY OTHER INCIDENTAL OR CONSEQUENTIAL DAMAGE. ANY IMPLIED WARRANTIES ARE LIMITED TO THE DURATION OF THIS WRITTEN LIMITED WARRANTY. This warranty is void if the manufacturing date and the serial number on the equipment has been removed or the equipment has been modified.

**EMISSION CONTROL SYSTEM INFORMATION**

The U.S. and California Clean Air Acts

EPA and California regulations require all manufacturers to furnish written instructions describing the operation and maintenance of emission control systems. The following instructions and procedures must be followed in order to keep the emissions from your DEK engine within the emission standards. Maintenance, replacement, or repair of the emission control devices and systems may be performed by any engine repair establishment or individual, using parts that are "certified" to EPA standards.

The emission control systems on your DEK engine were designed, built, and certified to conform with EPA and California emission regulations. We recommend the use of genuine DEK parts whenever you have maintenance done. These original-design replacement parts are manufactured to the same standards as the original parts, so you can be confident of their performance. The use of replacement parts that are not of the original design and quality may impair the effectiveness of your emission control system. A manufacturer of an aftermarket part assumes the responsibility that the part will not adversely affect emission performance. The manufacturer or re-builder of the part must certify that use of the part will not result in a failure of the engine to comply with emission regulations.

Other fine products offered by **DEK** Heavy Duty Power Equipment



Commercial Lawn Mowers

Rev: 2/26/08



Heavy Duty Pressure Washers



Rental Grade Chipper Shredders



Generator Accessories

DEK® is exclusively distributed by GXi International, LLC