



Charcoal Grill 580

**Product Guide
Model 13301696**

Tools needed for assembly:

- Phillips Screwdriver
- Flat Head Screwdriver
- Adjustable wrench

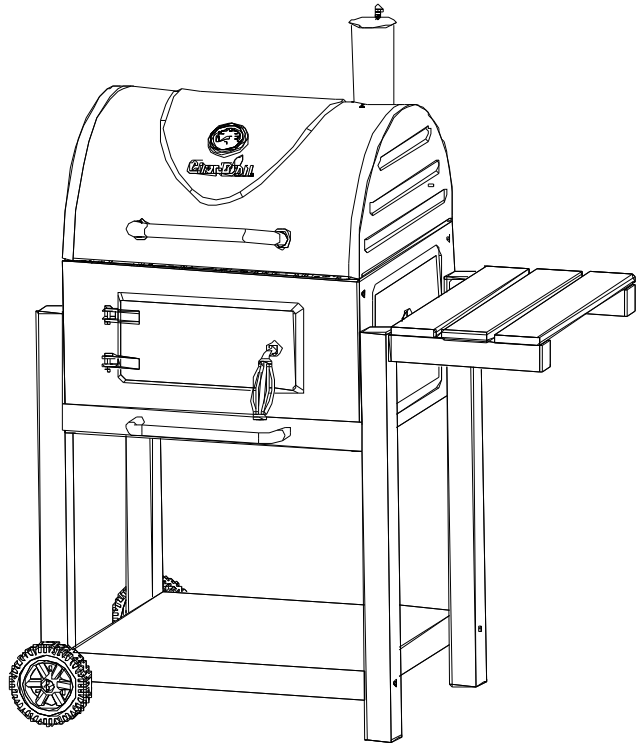

IMPORTANT: Fill out the product record information below.

Model Number _____
Date Purchased _____

FOR OUTDOOR USE ONLY

	WARNING	
<p>CARBON MONOXIDE HAZARD Burning charcoal inside can kill you. It gives off carbon monoxide, which has no odor. NEVER burn charcoal inside homes, vehicles, or tents.</p>		

	CAUTION	
<p>Read and follow all safety statements, assembly instructions, and use and care directions before attempting to assemble and cook.</p>		

	WARNING	
<p>Failure to follow all manufacturer's instructions could result in serious personal injury and/or property damage.</p>		

	CAUTION	
<p>Some parts may contain sharp edges! Wear protective gloves if necessary.</p>		

INSTALLER/ASSEMBLER:

Leave this manual with consumer.

CONSUMER:

Keep this manual for future reference.

	CAUTION	
<p>THIS UNIT IS HEAVY! DO NOT attempt to assemble without a helper.</p>		

If you have questions or need assistance during assembly, please call 1-800-241-7548.
To insure your satisfaction and for follow-up service, register your appliance online at www.charbroil.com/register

TABLE OF CONTENTS

Product Record Information	1
Safety Symbols	2
Preparing to use your Grill	3
Grill Maintenance	3
Cooking Tips	4-5
Limited Warranty	6
Parts List/ Parts Diagram	7
Assembly	8-16
Hardware List	17
Registration Card	20

This instruction manual contains important information necessary for the proper assembly and safe use of the appliance.

Follow all warnings and instructions when using the appliance.

Safety Symbols

The symbols and boxes shown below explain what each heading means. Read and follow all of the messages found throughout the manual.



DANGER: Indicates an imminently hazardous situation which, if not avoided, will result in death or serious injury.



WARNING: Indicates a potentially hazardous situation which, if not avoided, could result in death or serious injury.



CAUTION: Indicates a potentially hazardous situation or unsafe practice which, if not avoided, may result in minor or moderate injury.



FAILURE TO READ AND FOLLOW INSTRUCTIONS FOR LIGHTING CHARCOAL MAY RESULT IN SERIOUS PERSONAL INJURY AND OR PROPERTY DAMAGE.



Most surfaces on this unit are hot when in use. Use extreme caution. Keep others away from unit. Always wear protective clothing to prevent injury.

Keep children and pets away.

Do not move this unit during operation.

Never substitute gasoline, kerosene or alcohol for charcoal starter. In some states, the use of charcoal starter is prohibited by law. In this case, paraffin-based starter cubes can be substituted for charcoal starter. Never use charcoal starter fluid with an electric starter.



CALIFORNIA PROPOSITION 65

1. Combustible by-products produced when using this product contains chemicals known to the State of California to cause cancer, birth defects, or other reproductive harm.
2. This product contains chemicals, including lead and lead compounds, known to the State of California to cause cancer, birth defects or other reproductive harm.

Wash your hands after handling this product.



All surfaces can be hot during use. Use protection as required to prevent burning.

Do not use this unit on or near combustible surfaces or structures such as wood decks, dry leaves or grass, vinyl or wood siding, etc.

SEE OWNERS MANUAL FOR IMPORTANT SAFETY INFORMATION.



For residential use only. Do not use for commercial cooking.

PREPARING TO USE YOUR GRILL

Before cooking with your grill, the following steps should be closely followed to both cure the finish and season the interior steel. Failure to properly follow these steps may damage the finish and/or impart metallic flavors to your first foods.

- Brush all interior surfaces including grills and grates with vegetable cooking oil.
- Build a small fire on the charcoal grate, being sure not to lay coals against the walls.
- Close lid, position butterfly dampers at approximately one quarter turn open. This burn should be sustained for at least two hours. Begin increasing the temperature by opening the butterfly dampers halfway and adding more charcoal. Your grill is now ready for use.

Rust can appear on the inside of your grill. Maintaining a light coat of vegetable oil on the interior surfaces will aid in the protection of your grill. Exterior surfaces of the grill may need occasional touch up. We recommend the use of commercially available black high temperature spray paint. NEVER PAINT THE INTERIOR OF THE GRILL!

Please see information regarding Uncoated Cast Iron Grates below.

First Time Use:

Before using a cast iron grate or other cast iron cooking tool, wash it thoroughly with a mild dishwashing liquid to remove the protective wax coating applied for shipping. Rinse with hot water and dry completely with a soft cloth or paper towel. NEVER ALLOW TO DRAIN DRY OR WASH IN A DISHWASHER. Now season the grates to prevent rust and sticking.

Seasoning:

A solid vegetable shortening is recommended for the initial seasoning. Spread a thin coating of solid vegetable shortening over the entire surface, including all corners, with a paper towel. Do not use salted fats such as butter or margarine. Preheat grill for 15 minutes; carefully place grates in the grill. Allow the grill to heat grates for 1 to 1 ½ hours. Allow the fire to burn out on its own, and leave cooking grates in grill until they are cool. Your cast iron cooking grates are now ready to use.

To Prevent Rusting:

Re-season your grates frequently, particularly when new. If rust occurs, it is an indication that the grates have not been seasoned enough or the seasoning has been burned off. Clean with a heavy brush like Char-Broil's Brush Hawg. Reapply vegetable shortening and heat as indicated above to re-season the grates.

Maintenance:

Do not do a burn-off after you grill, but rather leave the cooking residues on the grates to keep a protective coating on the cast iron. Do a burn-off just before you grill. The more you use your cast iron grates, the easier the maintenance will be. Store in a dry place. If you store your grates for an extended period of time, grease very lightly with vegetable shortening, then wipe dry with a paper towel.

GRILLING

Charcoal is recommended, however, wood or a combination of both may be used as the fuel source for grilling with the fuel source placed and ignited on the ash pan. Do not build too large of a fire. We recommend starting a fire with no more than 2 pound of charcoal (approximately 30 briquettes) and adding more as needed during cooking. After allowing the fire to burn down, place the cooking grate on the unit. Failure to read and follow instructions for lighting charcoal may result in serious personal injury and/or property damage.

GRILL MAINTENANCE

Frequency of clean up is determined by how often the grill is used. Make sure coals are completely extinguished before cleaning inside of the unit. Thoroughly rinse with water and allow to air dry before using again. Wipe out the interior of the unit with a cloth or paper towels.

When finished cooking, and the unit has adequately cooled, clean out all remaining ashes. Ashes collect moisture, which can lead to premature rusting and decay. Periodically coating the interior surfaces with vegetable oil will aid in the protection of your unit. Also, occasional touch up of the exterior paint will be required. Black, high-temperature spray paint is recommended. NEVER PAINT THE INTERIOR OF THE UNIT.

Cooking Surface: If a bristle brush is used to clean any of the grill cooking surfaces, ensure no loose bristles remain on cooking surfaces prior to grilling. It is not recommended to clean cooking surfaces while grill is hot.

COOKING TIPS

Building Your Fire



- 1.) Stack charcoal briquettes or wood into a pyramid-shaped pile on top of the charcoal grate. We recommend using 2 pound (approximately 30 briquettes) to start your fire, adding more as needed.
- 2.) If using lighter fluid, saturate the charcoal briquettes with lighter fluid and let it soak in for approximately 5 minutes. If using a chimney starter, electric starter, or other type of fire starter, light your fire according to the manufacturer's instructions.
- 3.) After allowing the lighter fluid to properly soak in, light the pile of briquettes in several locations to ensure an even burn. ***Always light the fire with the grill lid open.***
Leave lid open until briquettes are fully lit. Failure to do this could trap fumes from charcoal lighter fluid in grill and may result in a flash fire when lid is opened.
- 4.) Never add charcoal lighter fluid to hot or warm coals as flashbacks may occur causing injury.
- 5.) You are ready to begin cooking when the pile of briquettes ashes over and produces a red glow (approximately 12 – 15 minutes).
- 6.) Depending on your cooking method, either leave the briquettes in a pile or spread evenly across the charcoal grate using a long-handled poker.





****Always use caution when handling hot coals to prevent injury.***

Know When Your Fire is Ready

Successful charcoal grilling depends on a good fire. The general rule for knowing when your coals are ready for grilling is to make sure that 80 percent or more of the coals are ashy gray. If you have less than that, the coals are not ready, and if all of them are glowing red hot, the fire is probably too hot. Here are a few steps you can take to adjust the temperature of your fire:

- If it is too hot, spread the coals out a bit more, which makes the fire less intense.
- Raise or lower the adjustable charcoal grate.
- Partially close the vents in the grill, which reduces the amount of oxygen that feeds the fire.
- Use the indirect grilling method, with coals to either side of a drip pan and the food over the pan rather than directly over the coals.
- In the event of a severe flare-up, spray the flames with water from a squirt bottle. Be careful, spraying with water tends to blow ashes around and make a mess.
- Add briquettes 2 or 3 at a time to increase the burn time. Allow 10 minutes for coals to ash over before adding more.

	WARNING	
Always open lid <i>BEFORE</i> opening the ash door to check fire or fuel.		
Always open the ash door slowly. Never attempt to look inside the grill while opening the ash door when the grill is in use.		
Failure to follow these instructions could result in injury.		
Unburned gas can accumulate and cause a flash fire if the lid is not opened first.		

THE HEAT OF THE COALS			
	seconds you can hold the palm of your hand 4 inches above the coals	temperature range (F°)	visual cues
 HOT COALS	2	400 to 450	barely covered with gray ash; deep red glow
 MODERATELY HOT TO HOT COALS	3	375 to 450	thin coating of gray ash; deep red glow
 MODERATELY HOT COALS	4	325 to 375	significant coating of gray ash; red glow
 MODERATELY COOL COALS	5	300 to 325	thick coating of gray ash; dull red glow

Direct and Indirect Grilling

Direct Grilling - For most grilling, the ignited coals are spread in a single layer under the food. This is called direct grilling and is appropriate for relatively quick-cooking items such as hamburgers, steaks and most seafood. The single layer of coals emits even, steady heat, whether the grill lid is open or closed, and represents the way most people grill. For more control, pile some of the coals on one side of the grill where they will emit intense heat. You can move the food around on the grill, setting it over the very hot coals when you want to sear it or when a thick piece needs to cook a little more quickly. You can also use the adjustable charcoal grate and dampers to control the temperature in your grill.

Indirect Grilling - For items that take longer to cook, you will want to use indirect grilling. This method is for long, slow cooking in a covered grill. For indirect cooking, the coals are piled two or three coals deep on one side of the grill, or divided and piled on two sides. This leaves an empty space next to the coals or between them. Food cooked over indirect heat is often started over direct heat and then moved to the cooler (empty) part of the grill for even, slow cooking. To make the heat as even as possible, construct two piles of coals. It is common to place a metal drip pan in the empty space beside or between the coals, which is filled with water, wine, beer, broth, or a combination. Place the food directly over the drip pan. This injects a little extra moisture into the cooking environment and also catches dripping juices, which makes clean-up a little easier and reduces the possibility of flare-ups. (Remember to keep a spray bottle filled with water on hand to extinguish any flare-ups.) Once you get used to the indirect method, you may prefer to use it for more grilling tasks. Although it may take a little longer, it is an excellent cooking method and a sure way to prevent the food from burning and to promote even cooking.

Grilling with Wood Chips/Wood Chunks

For a more robust smoke flavor while using charcoal briquettes or lump charcoal, try adding wood chips or several wood chunks to the fire. Wood chunks are available in a variety of natural flavors, and can be used alone or in addition to charcoal. As a general rule, any hardwood that bears a fruit or nut is suitable for cooking. However, different woods have very different tastes. Experiment with different woods to determine your personal favorite, and always use well-seasoned wood. Green or fresh-cut wood can turn food black, and tastes bitter.

Our Recommendations:

Chicken - Alder, Apple, Hickory, Mesquite, Sassafras, Grapevines

Beef - Hickory, Mesquite, Oak, Grapevines

Pork - Fruitwoods, Hickory, Oak, Sassafras

Lamb - Fruitwoods, Mesquite

Veal - Fruitwoods, Grapevines

Seafood - Alder, Mesquite, Sassafras, Grapevines

Vegetables – Mesquite

USDA Recommended Internal Cooking Temperatures	
Ground Meat	
Beef, Pork, Veal, Lamb.....	160°F
Turkey, Chicken.....	165°F
Fresh Beef, Veal, Lamb	
Medium Rare.....	145°F
(let stand 3 minutes before cutting)	
Medium.....	160°F
Well Done.....	170°F
Poultry	
Chicken & Turkey, whole.....	165°F
Poultry Parts.....	165°F
Duck & Goose.....	165°F
Fresh Pork	
Medium Rare.....	145°F
(let stand 3 minutes before cutting)	
Medium.....	160°F
Well Done.....	170°F

LIMITED WARRANTY

This warranty only applies to units purchased from an authorized retailer. Manufacturer warrants to the **original consumer-purchaser** only that this product shall be free from defects in workmanship and materials after correct assembly and under normal and reasonable home use for the periods indicated below beginning on the date of purchase*. The manufacturer reserves the right to require that defective parts be returned, postage and or freight pre-paid by the consumer for review and examination.

<u>SCOPE OF COVERAGE</u>	<u>PERIOD OF COVERAGE</u>	<u>TYPE OF FAILURE COVERAGE</u>
All Parts	1 year from date of purchase*	PERFORATION, MANUFACTURING, AND MATERIAL DEFECTS ONLY

*Note: A dated sales receipt WILL be required for warranty service.

The original consumer-purchaser will be responsible for all shipping charges for parts replaced under the terms of this limited warranty.

This limited warranty is applicable in the United States and Canada only, is only available to the original owner of the product and is not transferable. **Manufacturer requires proof of your date of purchase. Therefore, you should retain your sales slip or invoice.** Registering your product is not a substitute for proof of purchase and the manufacturer is not responsible for or required to retain proof of purchase records.

This limited warranty applies to the functionality of the product ONLY and does not cover cosmetic issues such as scratches, dents, corruptions or discoloring by heat, abrasive and chemical cleaners or any tools used in the assembly or installation of the appliance, surface rust, or the discoloration of stainless steel surfaces. **RUST is not considered a manufacturing or materials defect.**

This limited warranty will not reimburse you for the cost of any inconvenience, food, personal injury or property damage.

ITEMS MANUFACTURER WILL NOT PAY FOR:

1. Shipping cost, standard or expedited, for warranty and replacement parts
2. Service calls to your home.
3. Repairs when your product is used for other than normal, single-family household or residential use.
4. Damage, failures, or operating difficulties resulting from accident, alteration, careless handling, misuse, abuse, fire, flood, acts of God, improper installation or maintenance, installation not in accordance with electrical or plumbing codes, or use of products not approved by the manufacturer.
5. Any food loss due to product failures or operating difficulties.
6. Replacement parts or repair labor costs for units operated outside the United States or Canada.
7. Pickup and delivery of your product.
8. Repairs to parts or systems resulting from unauthorized modifications made to the product.
9. The removal and/or reinstallation of your product.

DISCLAIMER OF IMPLIED WARRANTIES and LIMITATION OF REMEDIES

Repair or replacement of defective parts is your exclusive remedy under the terms of this limited warranty. In the event of parts availability issues, the manufacturer reserves the right to substitute like or similar parts that are equally functional.

Manufacturer will not be responsible for any consequential or incidental damages arising from the breach of either this limited warranty or any applicable implied warranty, or for failure or damage resulting from acts of God, improper care and maintenance, grease fire, accident, alteration, replacement of parts by anyone other than Manufacturer, misuse, transportation, commercial use, abuse, hostile environments (inclement weather, acts of nature, animal tampering), improper installation or installation not in accordance with local codes or printed manufacturer instructions.

THIS LIMITED WARRANTY IS THE SOLE EXPRESS WARRANTY GIVEN BY THE MANUFACTURER. NO PRODUCT PERFORMANCE SPECIFICATION OR DESCRIPTION WHEREVER APPEARING IS WARRANTED BY MANUFACTURER EXCEPT TO THE EXTENT SET FORTH IN THIS LIMITED WARRANTY. ANY IMPLIED WARRANTY PROTECTION ARISING UNDER THE LAWS OF ANY STATE, INCLUDING IMPLIED WARRANTY OF MERCHANTABILITY OR FITNESS FOR A PARTICULAR PURPOSE OR USE, IS HEREBY LIMITED IN DURATION TO THE DURATION OF THIS LIMITED WARRANTY.

Neither dealers nor the retail establishment selling this product has any authority to make any additional warranties or to promise remedies in addition to or inconsistent with those stated above. Manufacturer's **maximum liability**, in any event, shall not exceed the purchase price of the product paid by the original consumer.

NOTE: Some states do not allow an exclusion or limitation of incidental or consequential damages, so some of the above limitations or exclusions may not apply to you. This limited warranty gives you specific legal rights as set forth herein. You may also have other rights which vary from state to state. In the state of California only, if refinishing or replacement of the product is not commercially practicable, the retailer selling this product or the Manufacturer will refund the purchase price paid for the product, less the amount directly attributable to use by the original consumer-purchaser prior to discovery of the nonconformity. In addition, in the state of California only, you may take the product to the retail establishment selling this product in order to obtain performance under this limited warranty.

If you wish to obtain performance of any obligation under this limited warranty, you should write to:

**Consumer Relations
P. O. Box 1240
Columbus, GA 31902-1240**

Consumer returns will not be accepted unless a valid Return Authorization is first acquired. Authorized returns are clearly marked on the outside of the package with an RA number and the package is shipped freight/postage pre-paid. Consumer returns that do not meet these standards will be refused.

WS_1 Rev04

PARTS LIST

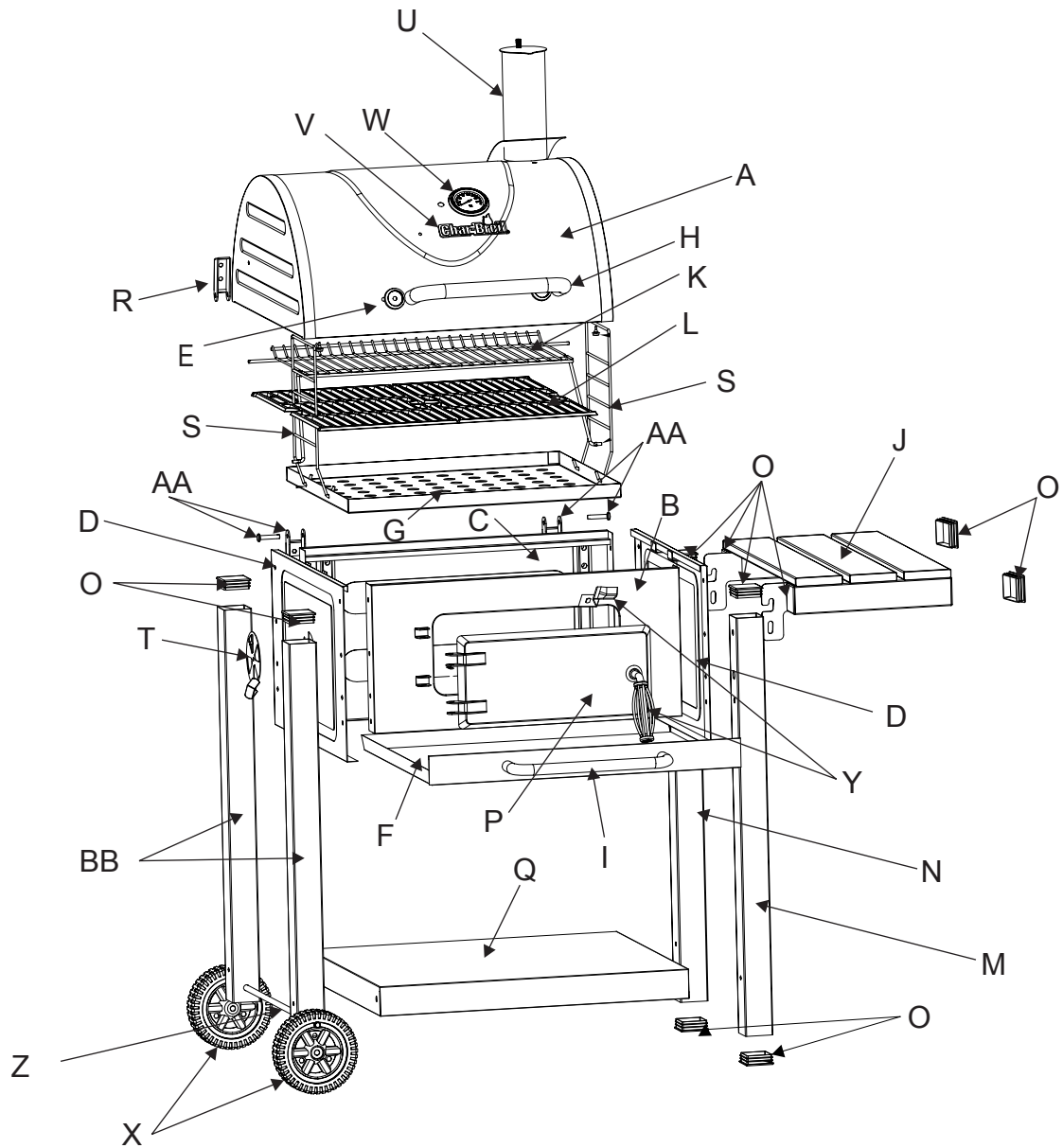

Key	Qty	Description
A	1	LID ASSEMBLY
B	1	FIREBOX FRONT PANEL
C	1	FIREBOX BACK PANEL
D	2	FIREBOX SIDE PANEL
E	2	BEZEL, F/LID HANDLE
F	1	ASH PAN
G	1	CHARCOAL PAN
H	1	HANDLE ,F/ LID
I	1	HANDLE, F/ ASH PAN
J	1	SIDE SHELF ASSEMBLY
K	1	SWING AWAY GRATE
L	2	COOKING GRATE
M	1	LEG, RIGHT FRONT
N	1	LEG, RIGHT REAR

Key	Qty	Description
O	10	LEG CAP
P	1	DOOR, CLEAN OUT
Q	1	BOTTOM SHELF
R	2	UPPER HINGE, F/LID
S	2	HANGER, F/ CHARCOAL PAN
T	2	BUTTERFLY DAMPER WHEEL
U	1	SMOKE STACK ASSEMBLY
V	1	LOGO PLATE KIT
W	1	TEMPERATURE GAUGE
X	2	WHEEL
Y	1	HANDLE KIT, F/CLEAN OUT DOOR
Z	1	WHEEL AXLE
AA	2	LOWER HINGE, F/LID
BB	2	LEG, LEFT FRONT/ REAR
Not Pictured		
...	1	HARDWARE PACK
...	1	ASSEMBLY INSTRUCTION, ENGLISH
...	1	ASSEMBLY INSTRUCTION, SPANISH

ASSEMBLY

1 First, get a helper, this unit is heavy and will require a second person for lifting and moving. Open the carton and lay it flat. This will give you a protective surface during assembly.

Assemble firebox side panels to the outside of the firebox back panel using $\frac{1}{4}$ -20 x $\frac{3}{4}$ " screws and $\frac{1}{4}$ " flange nuts. Make sure to use the top hole and the third hole counting from top down.

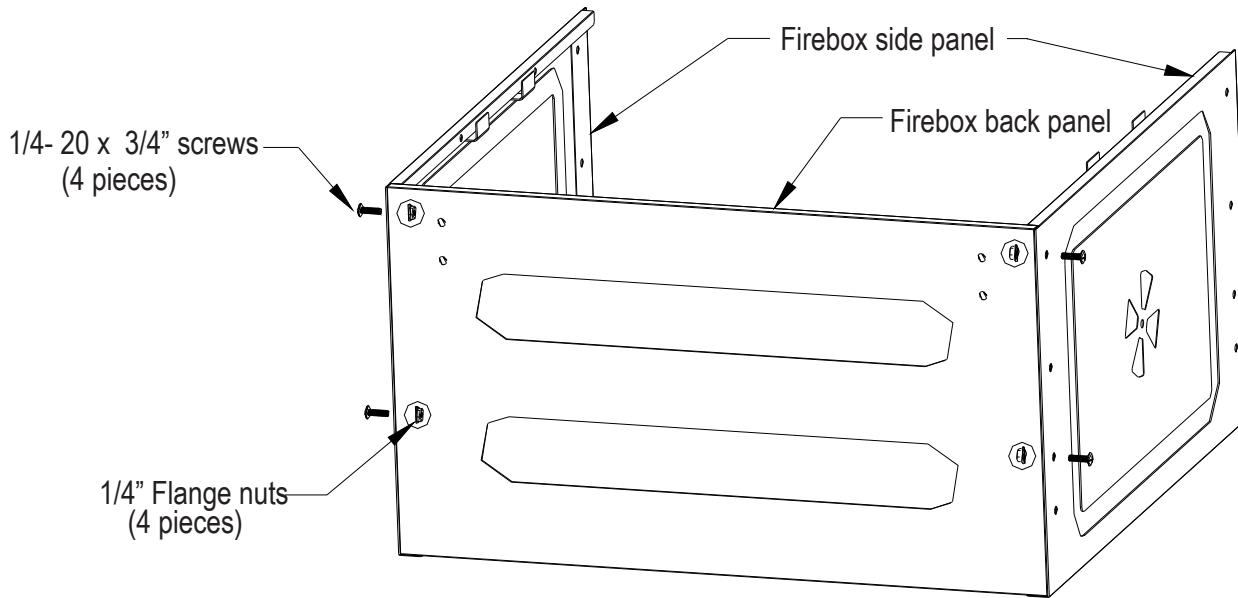

2 Assemble firebox front panel to firebox side panels using $\frac{1}{4}$ -20 x $\frac{3}{4}$ screws and $\frac{1}{4}$ " flange nuts, as shown, tighten all screws. Again make sure to use the top and third hole down.

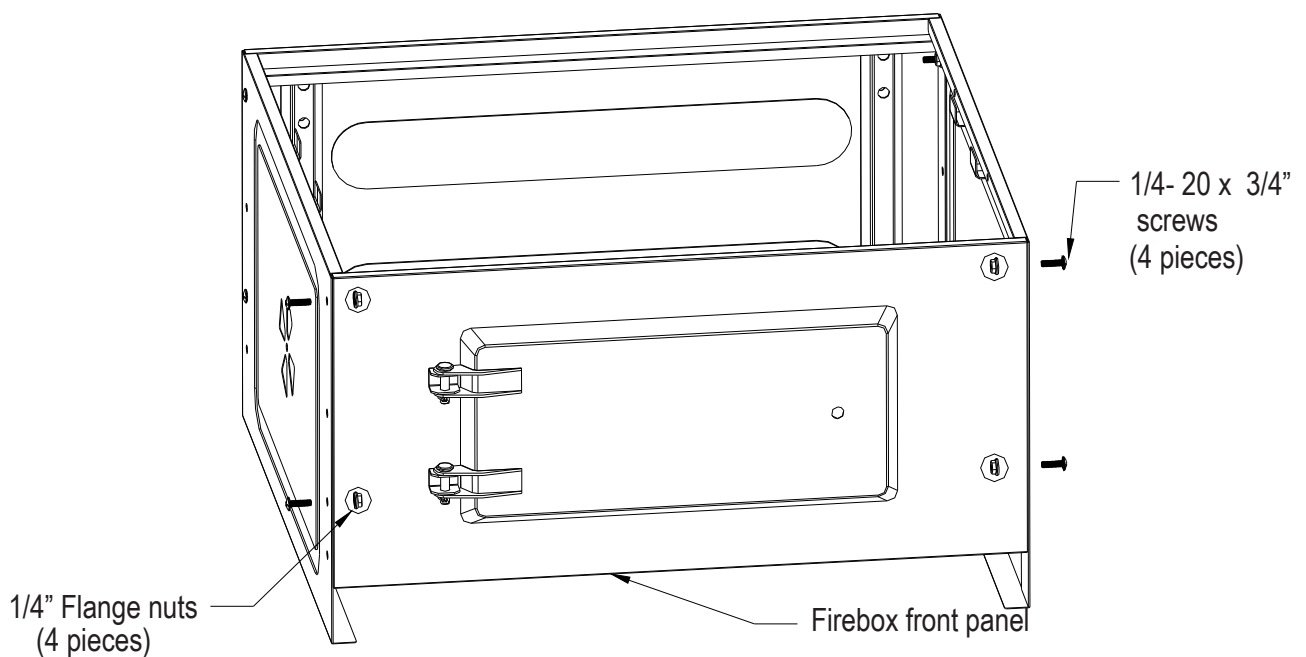

3 Assemble 2 left legs, 1 right rear leg and 1 right front leg to firebox and bottom shelf . Use four 1/4-20 x 2 1/2 "screws for the bottom shelf and eight 1/4-20 x 3/4" screws for firebox, tighten screws as shown in the figure.

Note: For easier assembly, lay grill with its front panel to the floor, attach the front legs, and then flip over onto its back panel to attach the back legs

Note: When attaching legs, make sure that the top 2 holes on right legs are facing each.

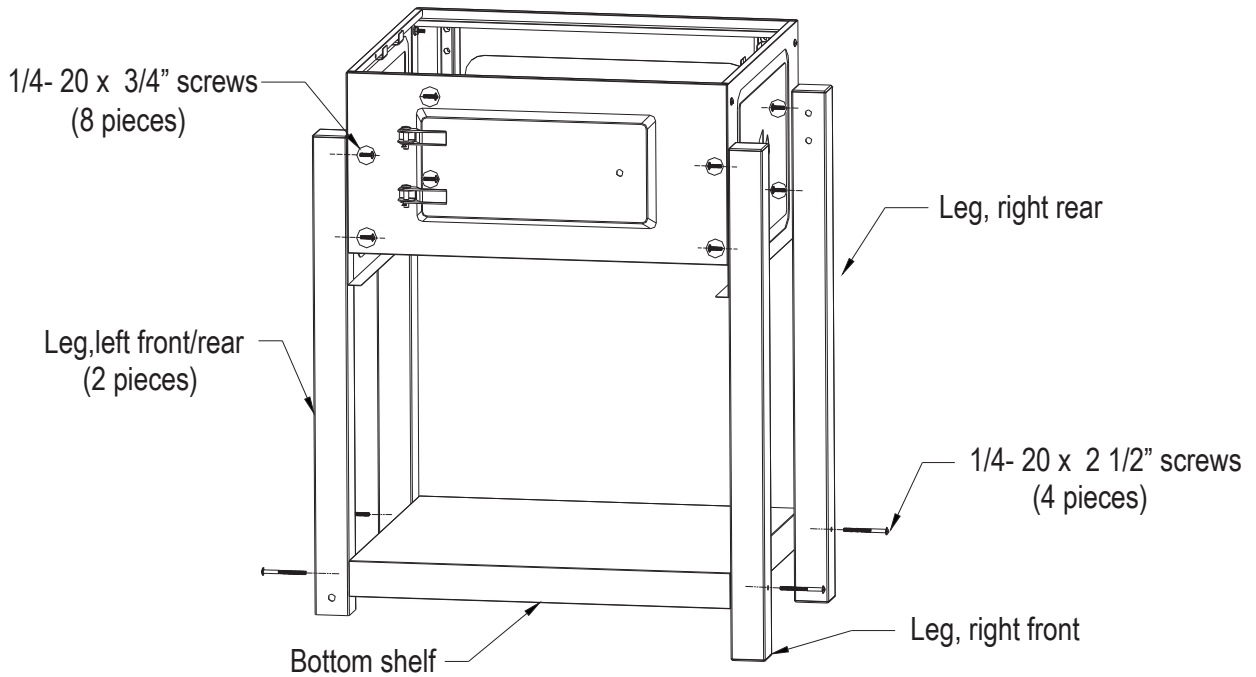

4 Set the grill upright, insert the wheel axle into left legs holes and assemble the two wheels. Install two 23.5 mm dia. washers onto axle. Insert large hitch pins into wheel axle holes. (Smaller hitch pins are for the lid.)

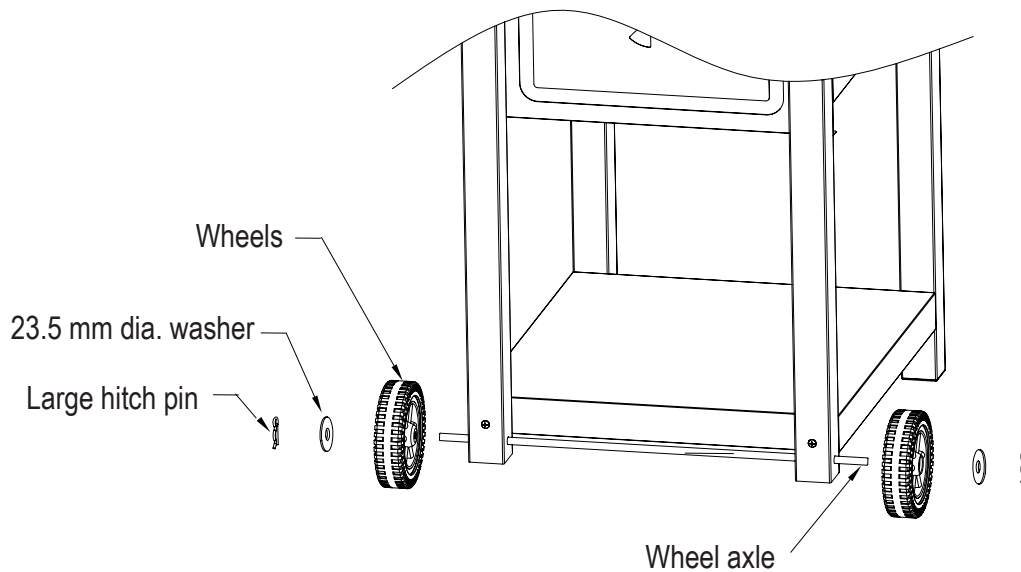

5 Attach butterfly damper wheels on outside of grill using two 1/4 - 20 x -3/4" screw and two 1/4" flange nut ,do not fully tighten the flange nut, this will allow for smooth rotation of the damper.

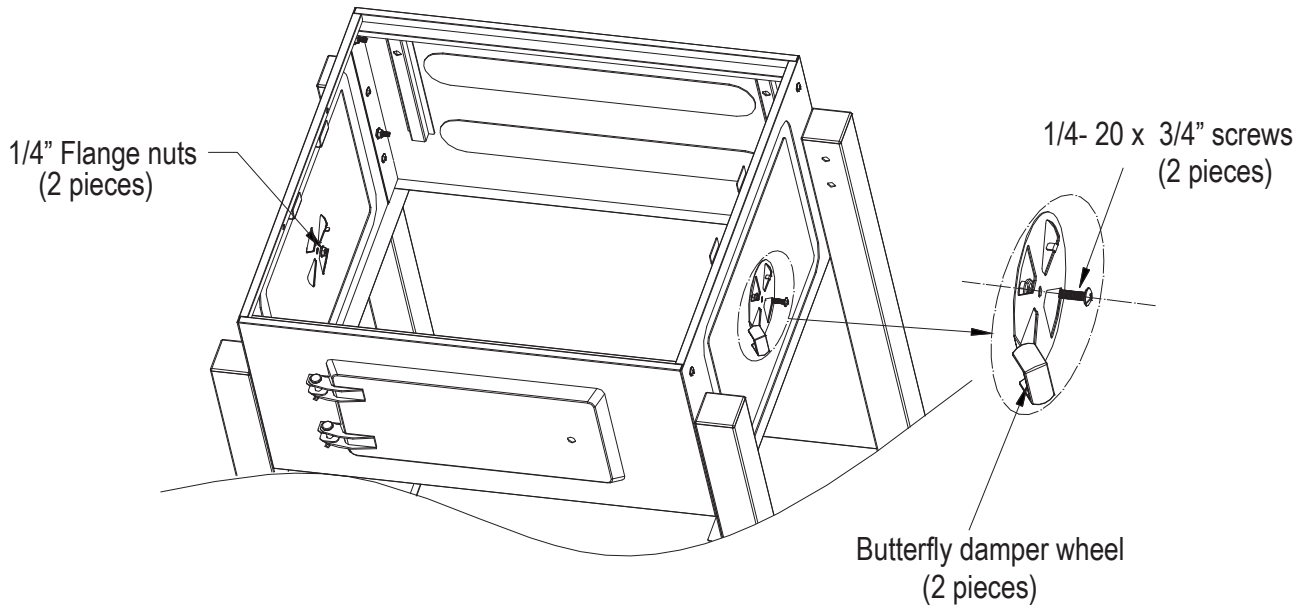

6 Attach the lower hinges to back panel by using four 1/4 - 20 x 1 1/2" screws

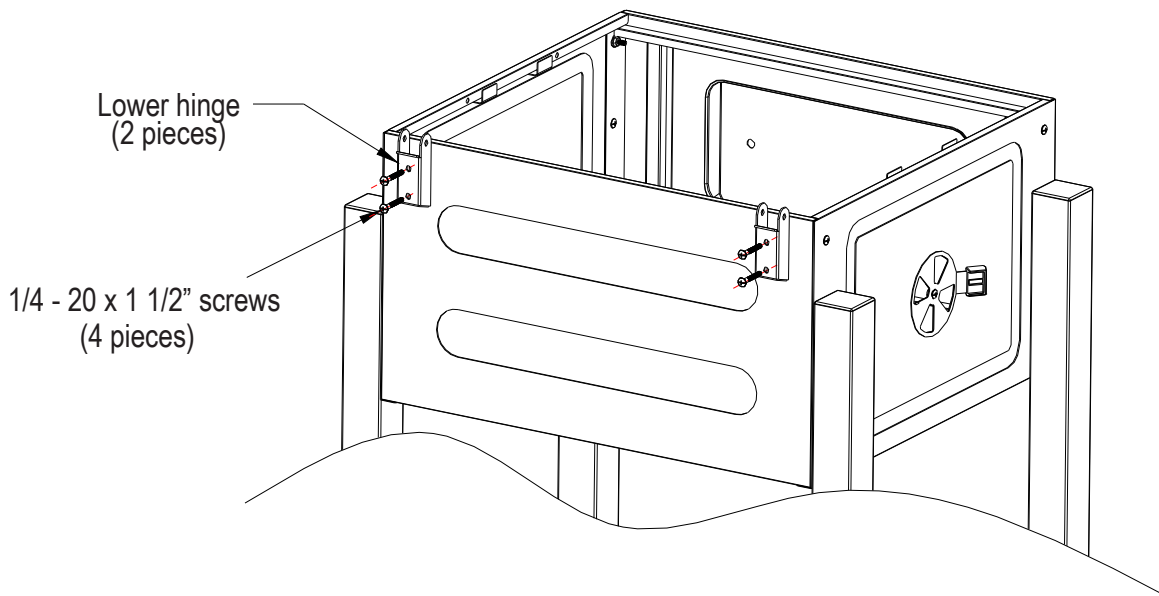

- 7** Assemble charcoal door spacer to charcoal door handle with front door latch and washer by using flange nut as shown.
Note: Check orientation of handle during assembly. It should point down when door is latched.

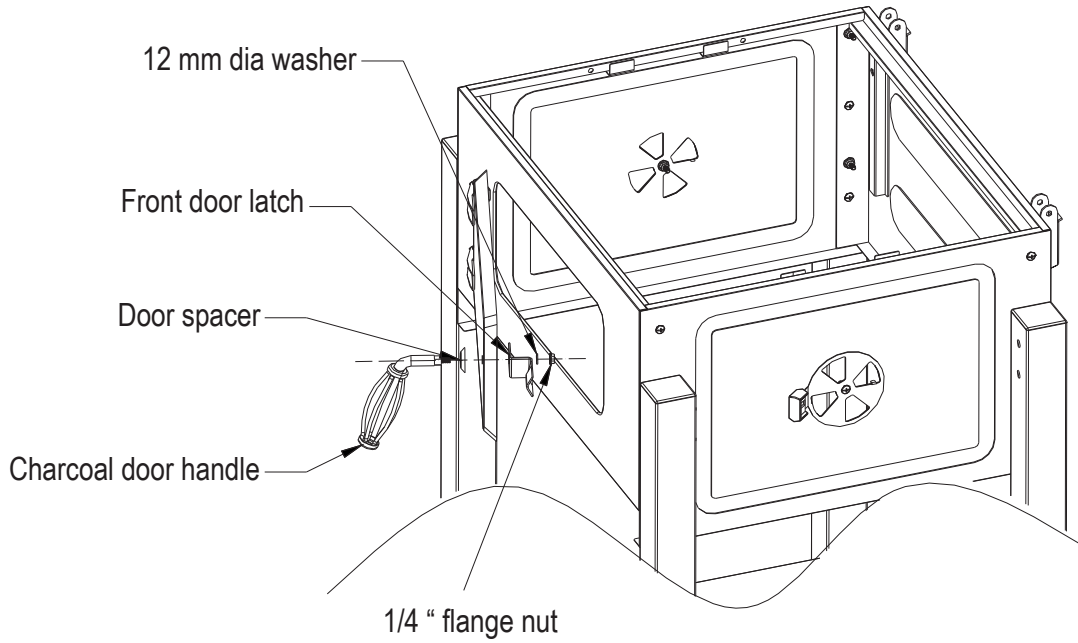

- 8** Attach upper hinges to lid by using four 1/4-20 x 1 1/4" screw and four 1/4" flange nuts.

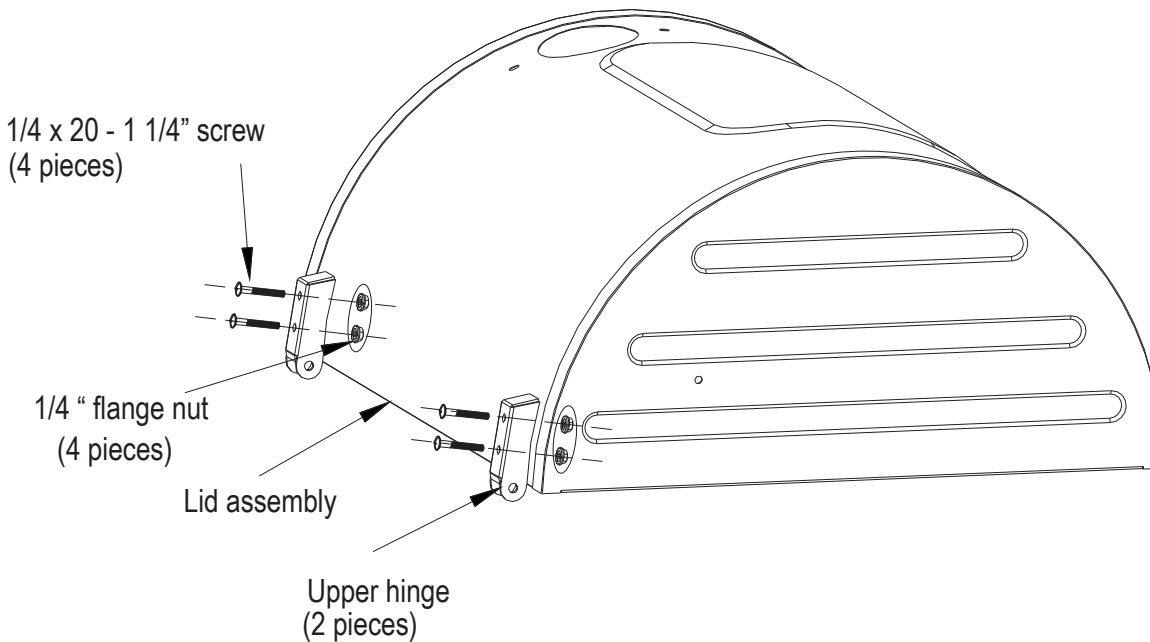

9 Place lid assembly on top of firebox then align hinge holes. Attach lid to firebox using 2 hinge pins . Once hinge pins are in place, insert hitch pin into hole in hinge pins.

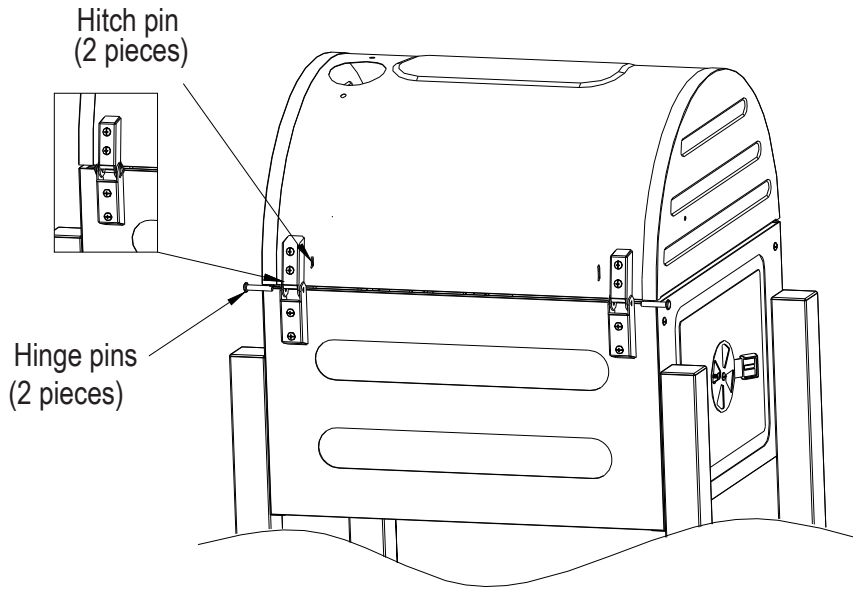

10 Attach lid handle to lid assembly using 2 handle bezels and two 1/4-20 x 3/4" screws and two washers as shown below. Insert silicone lid bumper onto the two holes on sides of lid assembly.

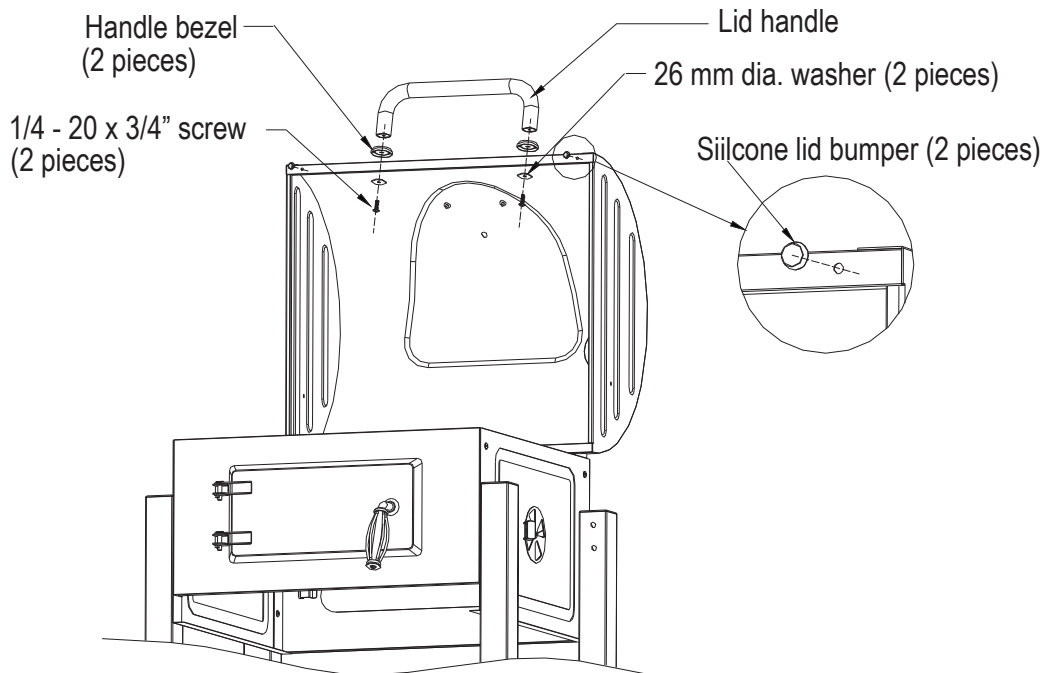

11 Insert smoke stack assembly into lid attach using two 1/4-20 x 3/4" screws and two 1/4" flange nuts.

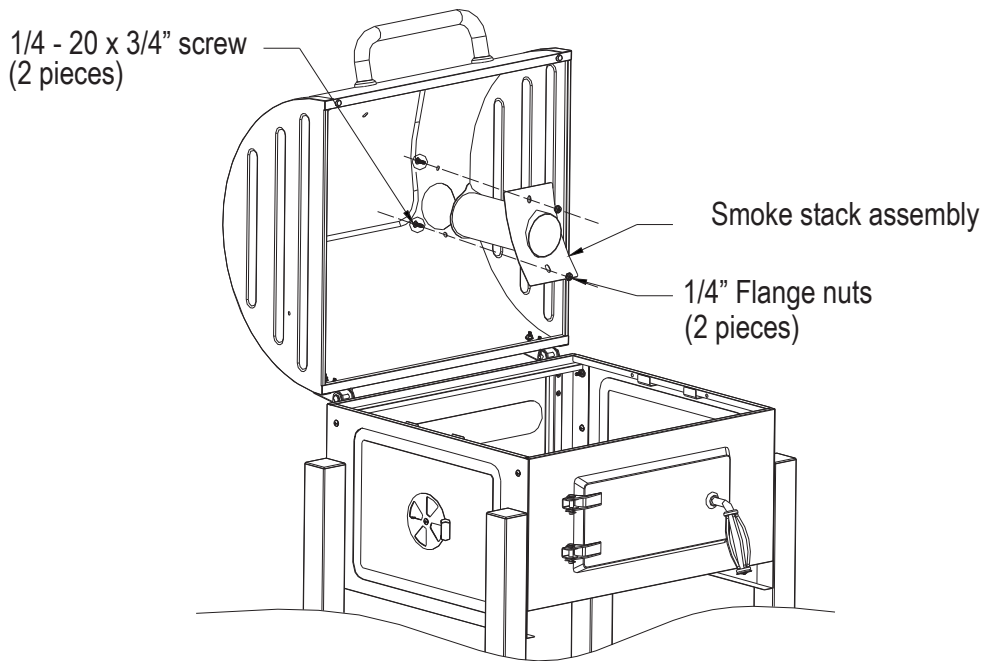

12 Attach side shelf assembly to right side of grill using four 1/4 - 20 x 1/2" screws, tighten.
Note: For ease of assembly- tighten top screw on each leg before mounting the side shelf. Assemble shelf using the upper holes. Raise and hold the shelf to the right position then attach the 2 bottom screws and tighten.

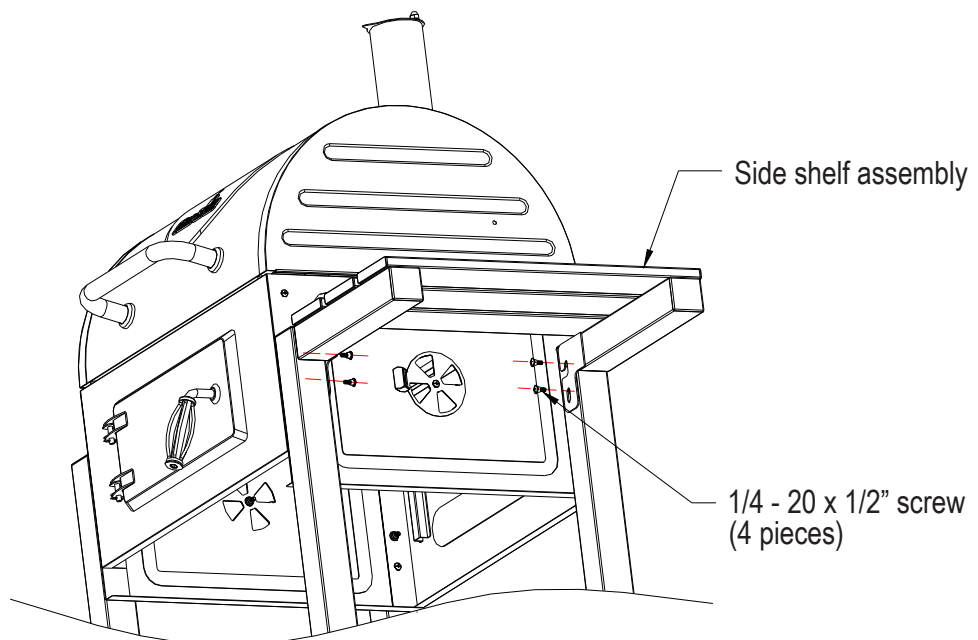

13

Attach ash pan handle to ash pan using two 1/4 - 20 x 3/4" screws.

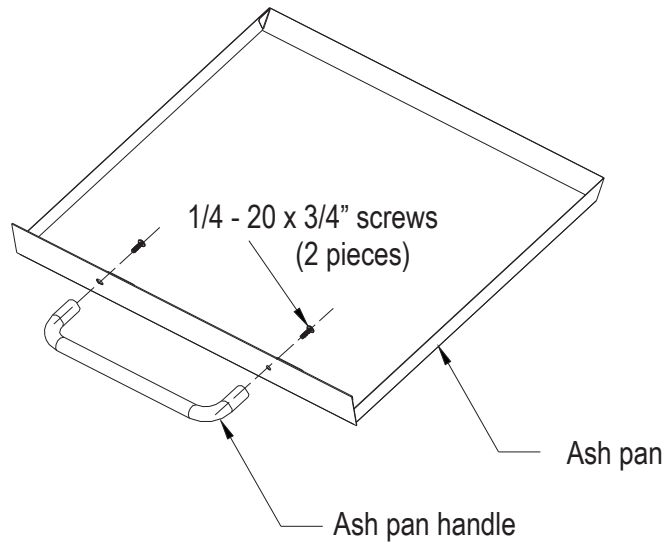

14

Insert the completed ash pan into slot underneath the main body of the grill.

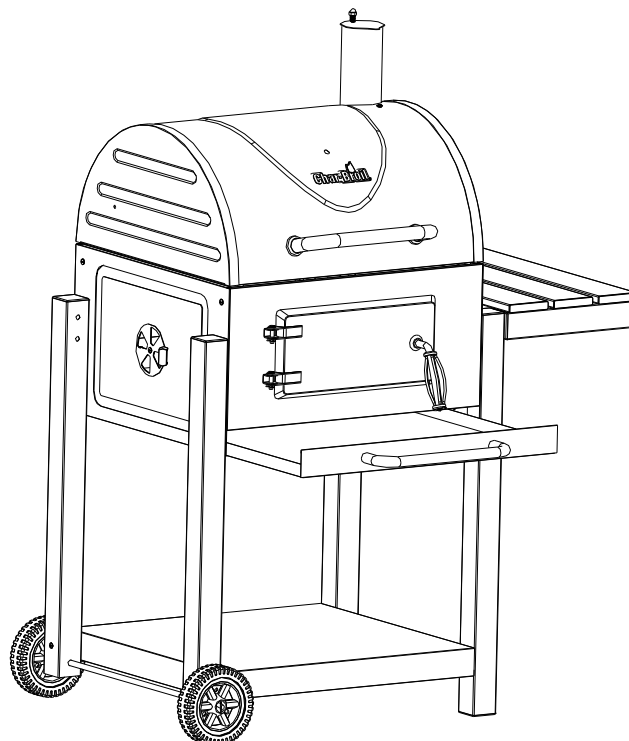

15

Install swing away grate into the holes at the bottom of the lid and at the top of grill firebox.

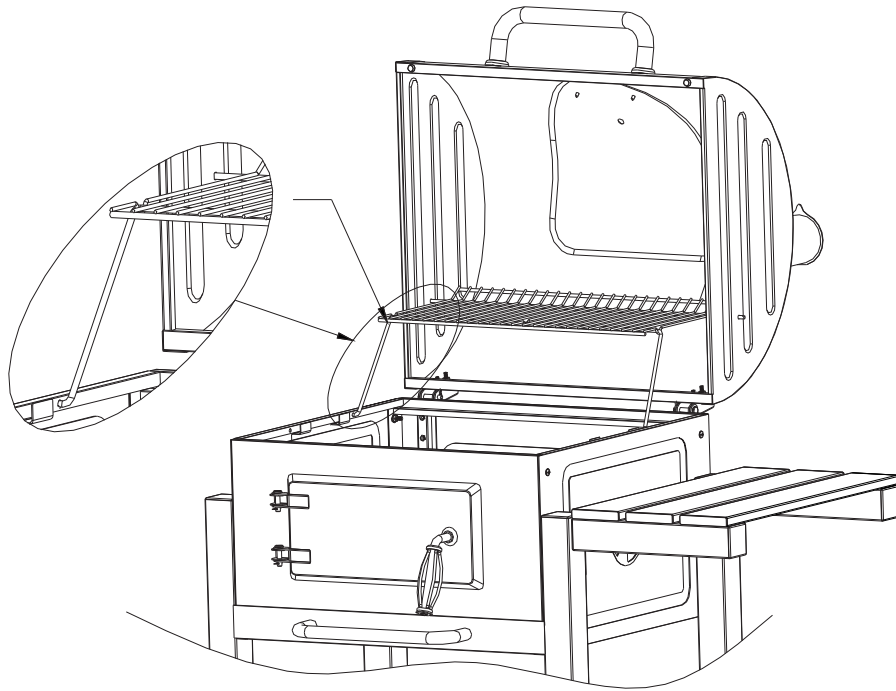

16

Attach 2 charcoal pan hangers to charcoal pan and place charcoal pan into grill. The charcoal pan hangers will hook onto the tabs on the inside of the grill.

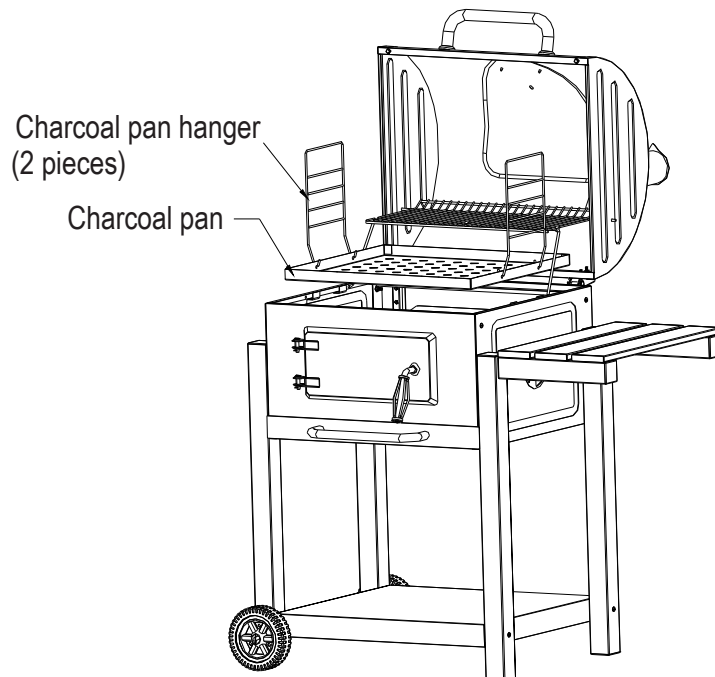

17

Place 2 cast iron cooking grate into the firebox. The cast iron cooking grates will rest on the front and rear edges of the firebox.

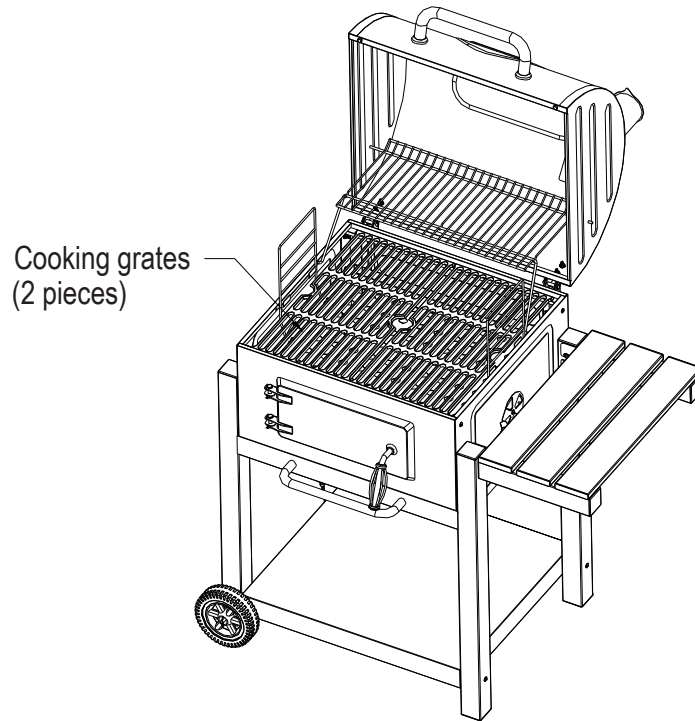

18

Remove nut from temperature gauge. Install temperature gauge into lid assembly and attach using nut.

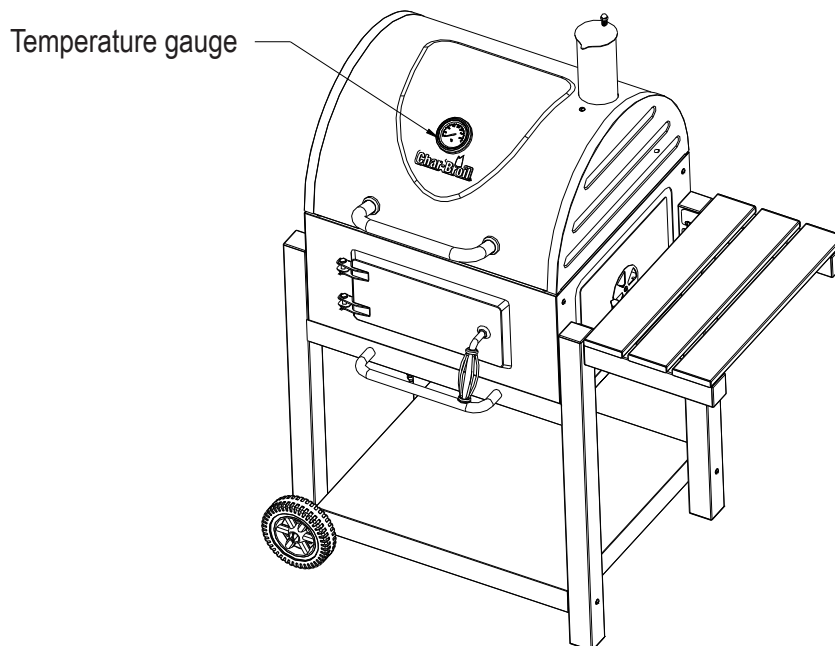

HARDWARE LIST

Hardware as shown is not actual size. You may have spare hardware after assembly is complete.

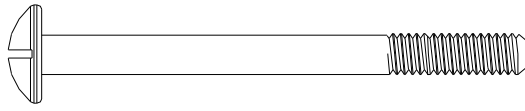

1/4 - 20 x 2 1/2" Screw 4 pieces

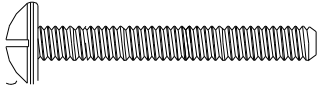

1/4" - 20 x 1 1/2" Screw 4 pieces

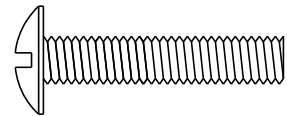

1/4" - 20 x 1 1/4" Screw 4 pieces

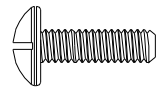

1/4" - 20 x 3/4" Screw 24 pieces

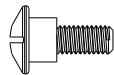

1/4- 20 x 1/2 " Screw 4 pieces

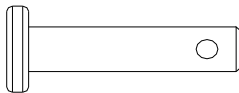

Hinge Pin 2 pieces

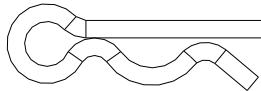

Hitch Pin 2 pieces



1/4" Flange Nut 17 pieces

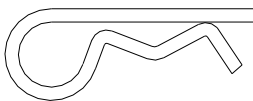

Large Hitch Pin 2 pieces

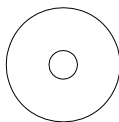

Lid Handle Washer 26 mm OD 2 pieces



Door Washer 12 mm OD 1 piece

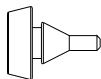

Silicone Lid Bumper 2 pieces

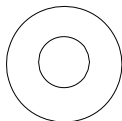

Wheel washer 23.5 mm OD 2 pieces

Notes:



Please register your product online at:
 Registre su producto en línea en:
 Veuillez enregistrer votre produit à l'adresse:

www.charbroil.com/register

(If you register online, you do not need to send in this registration card.)
 (Si registra en línea, no es necesario enviar esta tarjeta de registro.)
 (Si vous enregistrez votre produit en ligne, il n'est pas nécessaire d'envoyer la carte d'enregistrement.)

PLEASE FILL OUT THIS CARD AND ATTACH A COPY OF YOUR SALES RECEIPT. RETURN IT WITHIN 10 DAYS OF PURCHASE. FOR WARRANTY SERVICE PROOF OF PURCHASE WILL BE REQUIRED. THIS WARRANTY IS NON-TRANSFERABLE.

LLENE ESTA TARJETA Y DEVUELVALA DENTRO DE LOS 10 DIAS DE LA COMPRA. PARA EL SERVICIO DE GARANTIA ES NECESARIO QUE PRESENTE SU COMPROBANTE DE COMPRA. CONSERVE LA FACTURA. ESTA GARANTIA ES INTRANSFERIBLE.

VEUILLEZ COMPLETER CETTE CARTE ET LA RETOURNER DANS LES 10 JOURS SUIVANT L'ACHAT. POUR OBTENIR LE SERVICE SOUS GARANTIE, UNE PREUVE D'ACHAT DOIT ETRE PRESENTEE. VEUILLEZ CONSERVER VOTRE FACTURE. LA PRESENTE GARANTIE N'EST PAS TRANSFERABLE.

*Required | Necesario | Exigé

~ PLEASE PRINT ~ IMPRIMA POR FAVOR ~ S'IL VOUS PLAÎT IMPRIMER ~

* **1** First Name | Nombre | Prénom _____ Initial | Inicial | Initiale _____ Last Name | Apellido | Nom de Famillie _____

Address (number & street) | Dirección (número y calle) | Adresse (numéro et rue) _____ Apt Number | Nº de apart | Nº d'appt. _____

City | Ciudad | Ville _____ State | Estado | Province _____ Zip Code | Código Zip | Code Postal _____

* **2** E-mail Address | Dirección de correo electrónico | Adresse électronique _____ * **3** Phone Number | Número telefónico | Numéro de téléphone _____

* **4** Model Number | Número de modelo | Numéro de modèle _____

Char-Broil, LLC
 Columbus, GA 31904
 OUTDOOR GAS GRILL
 Model 443201500

TYPE OF GAS: LP/PROPANE at 11 in.c
 NAT at 7 in.c

For outdoor use only. If Stored indoors, Detach and Leave Cylinder Outdoor.
 CAUTION: Use only the gas pressure regulator supplied with this appliance.
 This regulator is set for an outlet pressure of 11 inches water column (0.40 psi).
 Turn off LP supply at cylinder when appliance is not in use.

Serial No. 000036
 Part No. 4584606
 This appliance can be used with LP gas and Natural gas. It is shipped from the factory adjusted for use with LP gas. Follow the instructions packaged with the Natural Gas Conversion Kit (Part Number 4584606) for gas conversion.
 458 21 158-2006 | CSA 1.6-2006
 Outdoor Cooking Gas Appliances

Serial Number | Número de serie | Numéro de série _____

STICKER ON PRODUCT

6 Date of Purchase | Fecha de compra | Date de l'achat _____ \$ _____

7 Store Name | Nombre de la tienda | Nom du magasin _____

8 Purchase Price | Precio de compra | Prix d'achat _____

9 Your Gender | Sexo | Sexe:
 Male | Masculino | Masculin
 Female | Femenino | Féminin

10 Which product are you registering?
 ¿Qué producto está registrando?
 Quel produit enregistrez-vous?

1. Gas Grill | Parrilla a gas | Gril au gaz
 2. Electric Grill | Parrilla eléctrica | Gril électrique
 3. Smoker | Ahumador | Fumoir
 4. Charcoal Grill | Parrilla a carbón | Barbecue au charbon
 5. Cooker/Fryer | Cocina/freidora | Cuisieur/Friteuse
 6. Other | Otro | Autre

Mail to: / Enviar a: / Envoyer à :

Char-Broil Warranty Registration
P.O. Box 1240
Columbus, GA 31902-1240

* **5** Attach copy of your sales receipt here.

Adjunte aqui la copia de su recibo de compra

Veillez attacher une copie de votre reçu ici.

We respect your privacy. | Respetamos su privacidad. | Nous respectons votre vie privée.

- If you prefer not to receive special offers and promotions from Char-Broil, please check here:
- Marque aquí si no desea recibir ofertas y promociones especiales de Char-Broil:
- Si vous préférez ne pas recevoir d'informations concernant des offres spéciales et des promotions de Charbroil, veuillez cocher ici:

Thank you for completing this questionnaire. | Gracias por completar este cuestionario. | Merci d'avoir bien voulu remplir ce questionnaire.

THANK YOU FOR YOUR RECENT PURCHASE FROM



CHECK OUT THESE GREAT FEATURES ON OUR WEBSITE

- Valuable product information
- Inspiring grilling accessories
- Reliable customer support
- Delicious recipes and tips from chefs
- Exciting events and promotions
- And much more!

REGISTER YOUR PRODUCT TO RECEIVE A
SPECIAL OFFER
CHARBROIL.COM/REGISTER