

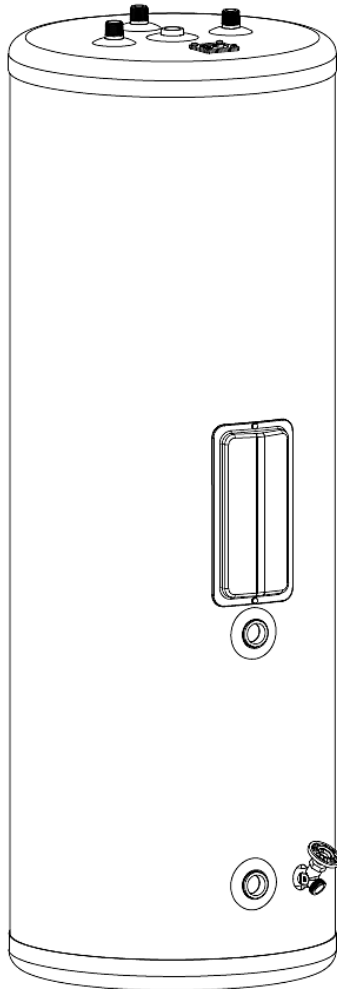

Westinghouse

Indirect Water Heaters



INSTALLATION

START-UP

MAINTENANCE

PARTS

Models

WI030 / WI040 / WI050

WI060 / WI080 / WI100

For Residential and Commercial Use

⚠ WARNING

This manual must only be used by a qualified installer/service technician. Read all instructions in this manual before installing. Perform steps in the given order. Failure to comply could result in substantial property damage, severe personal injury, or death.

NOTICE: *Westinghouse reserves the right to make product changes or updates without notice and will not be held liable for typographical errors in literature.*

The surfaces of these products contacted by consumable water contain less than 0.25% lead by weight, as required by the Safe Drinking Water Act, Section 1417.

NOTE TO CONSUMER: PLEASE KEEP ALL INSTRUCTIONS FOR FUTURE REFERENCE.

SPECIAL ATTENTION BOXES

The following defined terms are used throughout this manual to bring attention to the presence of hazards of various risk levels, or to important product information.

DANGER

DANGER indicates an imminently hazardous situation which, if not avoided, will result in death or serious injury.

WARNING

WARNING indicates a potentially hazardous situation which, if not avoided, could result in death or serious injury.

CAUTION

CAUTION indicates a potentially hazardous situation which, if not avoided, may result in minor or moderate injury.

CAUTION

CAUTION used without the safety alert symbol indicates a potentially hazardous situation which, if not avoided, may result in property damage.

FOREWORD

This manual is intended to be used in conjunction with other literature provided with the Indirect Water Heater. This includes all related control information. It is important that this manual, all other documents included with this system, and additional publications including the *Code for the Installation of Heat Producing Appliances* (latest version), be reviewed in their entirety before beginning any work.

Installation should be made in accordance with the regulations of the local code authorities and utility companies which pertain to this type of water heating equipment.

FOR THE INSTALLER

This water heater must be installed by qualified and licensed personnel. The installer should be guided by the instructions furnished with the water heater, and with local codes and utility company requirements.

INSTALLATIONS MUST COMPLY WITH:

Local, state, provincial, and national codes, laws, regulations and ordinances.

TABLE OF CONTENTS

PART 1 – GENERAL SAFETY INFORMATION	3
A. PRECAUTIONS	3
B. WHEN SERVICING THE WATER HEATING SYSTEM.....	4
C. HEATER WATER	4
D. FREEZE PROTECTION	4
E. CHEMICAL VAPOR CORROSION	4
F. WATER TEMPERATURE ADJUSTMENT	5
PART 2 – PREPARE THE WATER HEATER	5
A. LOCATING THE WATER HEATER	6
B. WATER CHEMISTRY REQUIREMENTS	7
PART 3 – HEATER PIPING	8
A. PLUMBING	8

B. BOILER CONNECTIONS 9

C. DOMESTIC PIPING INLET..... 9

D. AUXILIARY CONNECTIONS..... 9

E. FILLING THE HEATER..... 9

F. TEMPERATURE AND PRESSURE RELIEF VALVE 9

G. SCALDING 10

H. POTABLE EXPANSION TANK..... 11

I. PRESSURE DROP SIZING FOR CIRCULATOR..... 11

J. PIPING 12

PART 4 – HEATER CONTROL AND WIRING 14

 A. CONTROL 14

 B. WIRING..... 15

 C. WIRING DIAGRAMS 15

PART 5 – START-UP AND OPERATION..... 16

PART 6 – MAINTENANCE AND TROUBLESHOOTING 18

CUSTOMER INSTALLATION RECORD FORM..... 20

PART 1 – GENERAL SAFETY INFORMATION

A. PRECAUTIONS

This water heater is approved for indoor installations only, and it not intended for use as a pool heater. Clearance to combustible materials: 0” top, bottom, sides and back. Heater must have room for service: 24” front, 6” top, and 0” sides are minimum recommended service clearances. (A combustible door or removable panel is acceptable front clearance.) This water heater has been approved for closet installation, and installation on combustible flooring. Install the water heater in a location where temperature and pressure relief valve discharge or a leak will not result in damage to the surrounding area. If such a location is not available, install an auxiliary catch pan.

⚠ WARNING

INSTALLER – Read all instructions in this manual before installing. Perform steps in the order given.
--

USER – This manual is for use only by a qualified heating installer/service technician. Have this heater serviced/inspected by a qualified service technician annually.
--

FAILURE TO ADHERE TO THE GUIDELINES ON THIS PAGE CAN RESULT IN SUBSTANTIAL PROPERTY DAMAGE, SEVERE PERSONAL INJURY, OR DEATH.
--

⚠ WARNING

NOTE: If the heater is exposed to the following, do not operate until all corrective steps have been made by a qualified serviceman:

- | |
|--|
| <ol style="list-style-type: none"> 1. FIRE 2. DAMAGE 3. WATER |
|--|

Any claims for damage or shortage in shipment must be filed immediately against the transportation company by the consignee.
--

CAUTION

High heat sources (sources generating heat 100°F / 37°C or greater, such as stove pipes, space heaters, etc.) may damage plastic components of the water heater as well as plastic vent pipe materials. Such damages ARE NOT covered by warranty. It is recommended to keep a minimum clearance of 8” from high heat sources. Observe heat source manufacturer instructions, as well as local, state, provincial, and national codes, laws, regulations and ordinances when installing this water heater and related components near high heat sources.

NOTE: OBTAIN ALL APPLICABLE PERMITS AND OBEY ALL LOCAL CODES.

NOTE: Install all system components and piping in such a manner that does not reduce the performance of any fire rated assembly.
DO NOT USE THIS WATER HEATER IF ANY PART HAS BEEN UNDERWATER. Immediately call a qualified service technician.

CAUTION

Any claims for damage or shortage in shipment must be filed immediately against the transportation company by the consignee.

B. WHEN SERVICING THE WATER HEATING SYSTEM

- To avoid electric shock, disconnect electrical supply before performing maintenance.
- To avoid severe burns, allow water heater and associated equipment to cool before servicing.

C. HEATER WATER

- Do not use petroleum-based cleaning or sealing compounds in a water heating system. Gaskets and seals in the system may be damaged. This can result in substantial property damage.
- Do not use "homemade cures" or "heater patent medicines". Damage to heater, substantial property damage, and/or serious personal injury may result.

NOTICE FOR SINGLE-WALL HEAT EXCHANGER MODELS

Per the Uniform Plumbing Code:

Single-wall heat exchangers are permitted if they satisfy all of the following requirements:

1. The heat transfer medium is potable water or contains only substances which are recognized as safe by the U.S. Food and Drug Administration (FDA).
2. The pressure of the heat transfer medium is maintained less than the normal minimum operating pressure of the potable water system (steam systems must comply with this statement).
3. The equipment is permanently labeled to indicate that only additives recognized as safe by the FDA shall be used as the heat transfer medium.

Other heat exchanger designs may be permitted where approved by the Administrative Authority.

D. FREEZE PROTECTION

NOTE: Consider piping and installation when determining heater location. Place water heater as close to the boiler as possible, in a location not prone to freezing.

CAUTION

Failure of the water heater due to freeze related damage IS NOT covered by warranty.

CAUTION

In water heaters with single wall heat exchangers, the heat transfer fluid must be water or nontoxic food grade glycol, FDA rated "generally recognized as safe" (GRAS) and having a toxicity rating or class of 1, as listed in Clinical Toxicology of Commercial Products, 5th edition. Ensure the system is permanently labeled to indicate any additives used in the heat transfer fluid.

WARNING

NEVER use any toxic chemical, including automotive, standard glycol antifreeze, or ethylene glycol made for hydronic (non-potable) systems. These chemicals can attack gaskets and seals in water systems, are poisonous if consumed, and can cause injury or death.

E. CHEMICAL VAPOR CORROSION

NOTE: DAMAGE TO THE WATER HEATER OR RELATED COMPONENTS CAUSED BY EXPOSURE TO CORROSIVE VAPORS IS NOT COVERED BY WARRANTY. The limited warranty is voided when failure of water tank is due to a corrosive atmosphere. (Refer to the limited warranty for complete terms and conditions).

PRODUCTS TO AVOID	AREAS LIKELY TO HAVE CONTAMINANTS
Spray cans containing fluorocarbons	Dry cleaning/laundry areas and establishments
Permanent wave solutions	Swimming pools
Chlorinated waxes/cleaners	Metal fabrication plants
Chlorine-based swimming pool chemicals	Beauty shops
Calcium chloride used for thawing	Refrigeration repair shops
Sodium chloride used for water softening	Photo processing plants
Refrigerant leaks	Auto body shops
Paint or varnish removers	Plastic manufacturing plants
Hydrochloric or Muriatic acid	Furniture refinishing areas and establishments
Cements and glues	New building construction
Antistatic fabric softeners used in clothes dryers	Remodeling areas
Chlorine-type bleaches, laundry detergents, and cleaning solvents	Garages and workshops
Adhesives used to fasten building products	

Table 1 – Chemical Contaminants

F. WATER TEMPERATURE ADJUSTMENT

If the water heater is going to have a set temperature above 120°F, you must use an ASSE 1017 rated mixing valve to avoid severe burns or death from scalding temperature.

⚠ WARNING

Households with small children, disabled, or elderly persons may require a 120°F or lower temperature setting to prevent severe personal injury or death due to scalding.

APPROXIMATE TIME / TEMPERATURE RELATIONSHIPS IN SCALDS

120°F	More than 5 minutes
125°F	1 ½ to 2 minutes
130°F	About 30 seconds
135°F	About 10 seconds
140°F	Less than 5 seconds
145°F	Less than 3 seconds
150°F	About 1 ½ seconds
155°F	About 1 second

Table 2

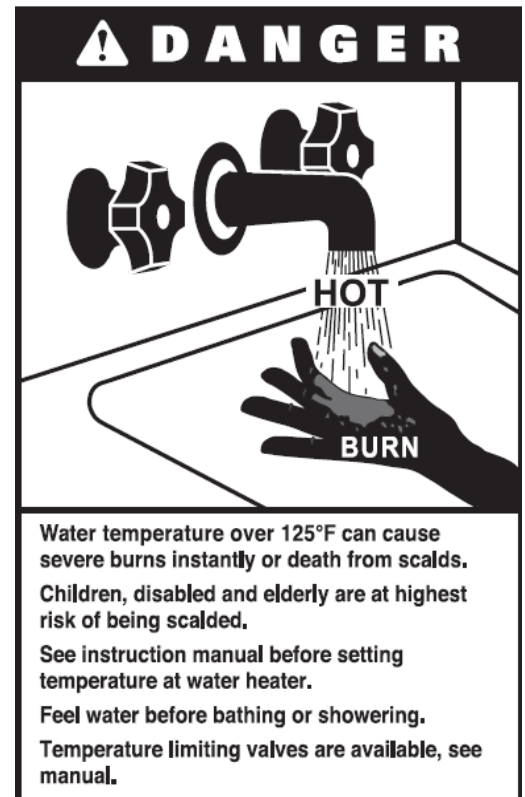

PART 2 – PREPARE THE WATER HEATER

CAUTION

UNCRATING HEATER – Any claims for damage or shortage in shipment must be filed immediately against the transportation company by the consignee.

CAUTION

COLD WEATHER HANDLING – If the heater has been stored in a very cold location (BELOW 0°F) before installation, handle with care until the plastic components come to room temperature.

Remove all sides of the shipping crate to allow the heater to be moved into its installation location.

NOTE: A drain valve is included with the water heater.

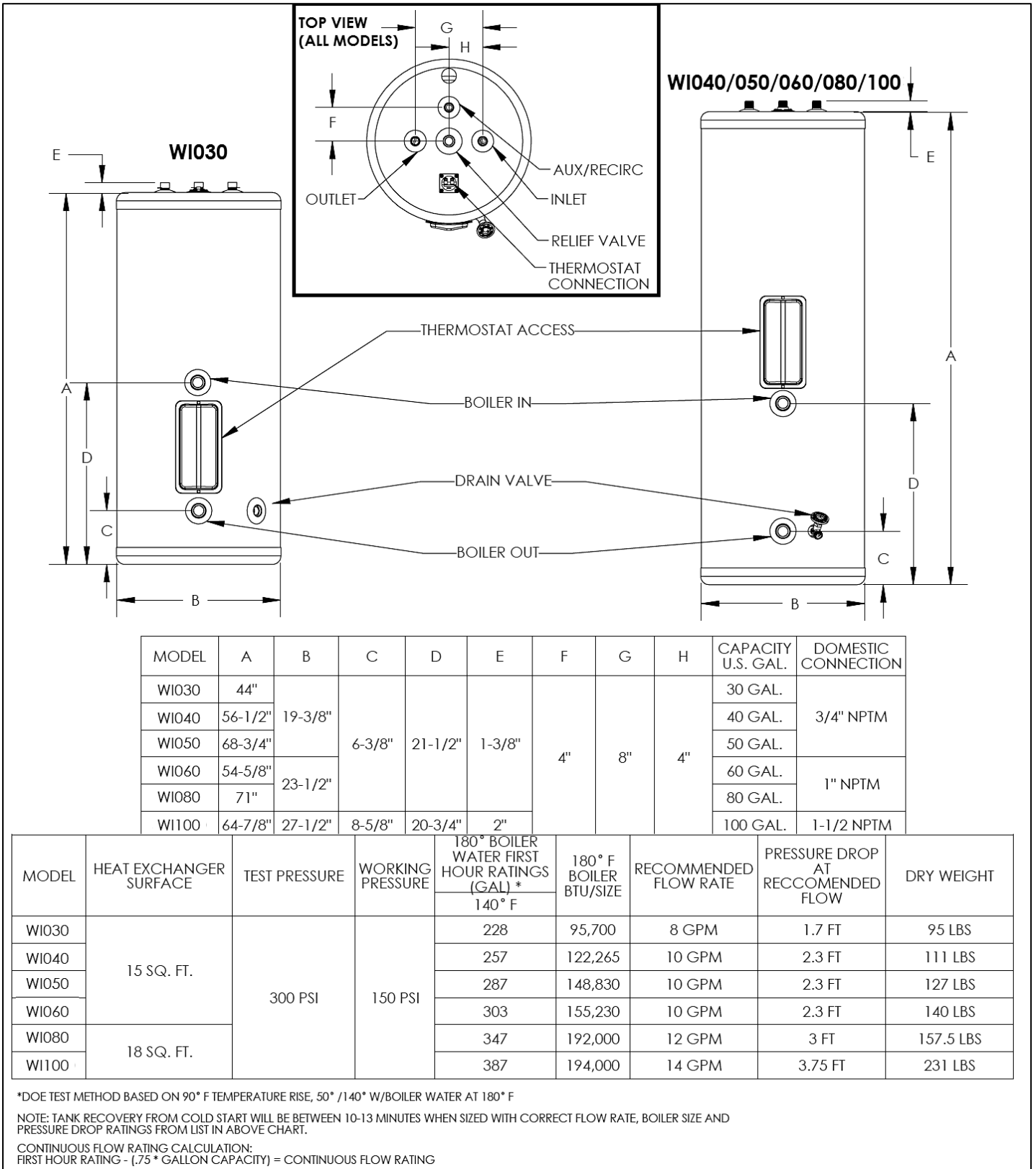

Figure 1 – Specifications and Dimensions

A. LOCATING THE WATER HEATER

This water heater is certified for indoor use only. DO NOT INSTALL OUTDOORS. Outdoor installations ARE NOT covered by warranty.

Choose a location for the water heater as centralized to the piping system as possible. Also, locate the water heater and domestic water piping where it will not be exposed to freezing temperatures. All piping should be insulated. Additionally, place the water heater so that the drain, controls, and inlets/outlets are easily accessible.

CAUTION

Locate the water heater where any leakage from the relief valve, related piping, tank, or connections will not result in damage to surrounding areas or lower floors of the building. The water heater should be located near a floor drain, or installed in a drain pan. Westinghouse will NOT be held liable for leakage damages.

NOTE: To save on heating costs and improve energy efficiency, keep the distance between the boiler and water heater to a minimum to reduce heat loss from excess piping and keep friction loss to a minimum. Ensure all piping between the boiler and water heater is properly insulated to minimize heat loss.

The water heater may be located some distance from the boiler provided the circulator meets flow requirements through the coil. The greater the distance from the water heater to the boiler, the longer the response will be to a call for domestic hot water.

CAUTION

DO NOT install this water heater in close proximity to high heat sources (temperatures greater than 100°F, such as boiler flue pipes, ducting, etc.). Doing so could result in damages to the water heater. Such damages ARE NOT covered by warranty. Westinghouse recommends a clearance of at least 6" from the water heater to high heat sources.

This water heater must be installed vertical on a level surface.

WARNING

Ensure water heater location can support the entire filled weight of the tank. Failure to properly support the tank could result in property damage, serious personal injury, or death.

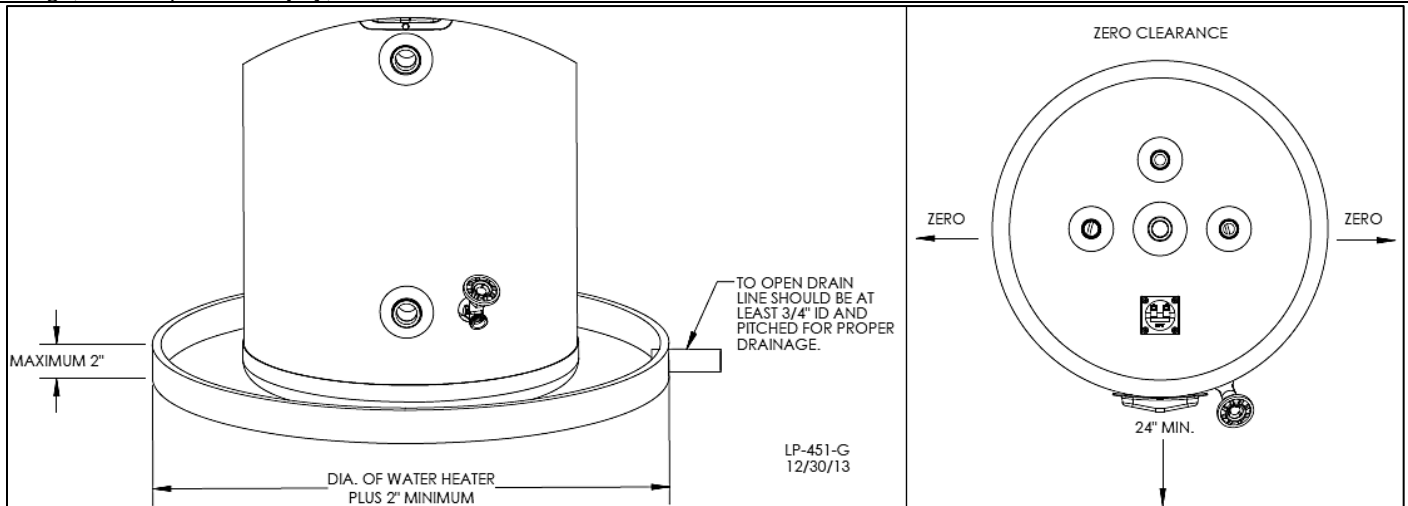

Figure 2 – Recommended Service Clearances

NOTE: If you do not provide the minimum clearances shown in Figure 2, it might not be possible to service the heater without removing it from the space.

DANGER

This water heater must not be located near flammable liquids such as gasoline, butane, liquefied propane, adhesives, solvents, paint thinners, etc., as the controls of this water heater could ignite these vapors and cause an explosion, resulting in property damage, severe personal injury, or death.

B. WATER CHEMISTRY REQUIREMENTS

CAUTION

Chemical imbalance of the water supply may affect efficiency and cause severe damage to the water heater and associated equipment. Westinghouse recommends having water quality professionally analyzed to determine whether it is necessary to install a water softener. It is important that the water chemistry on both the domestic hot water and central heating sides are checked before installing the water heater, as water quality will affect the reliability of the system. Failure of a water heater due to lime scale build-up, low pH, or other chemical imbalance IS NOT covered by the warranty.

CAUTION

Operating temperatures above 135°F will further accelerate the build-up of lime scale and may shorten the service life of the water heater. Failure of the water heater due to lime scale build-up on the heating surface, low pH, or other chemical imbalance IS NOT covered by the warranty.

Outlined on the following page are water quality parameters which need to be met in order for the system to operate efficiently for many years.

Water Hardness

Water hardness is mainly due to the presence of calcium and magnesium salts dissolved in water. The concentration of these salts is expressed in mg/L, ppm, or grains per gallon as a measure of relative water hardness. Grains per gallon is the common reference measurement used in the U.S. water heater industry. Hardness expressed as mg/L or ppm may be divided by 17.1 to convert to grains per gallon. Water may be classified as very soft, slightly hard, moderately hard, or hard based on its hardness number. The minerals in the water precipitate out as the water is heated and cause accelerated lime scale accumulation on a heat transfer surface. This lime scale build-up may result in premature failure of the water heater. Operating temperatures above 135°F will further accelerate the build-up of lime scale and may shorten the service life of the water heater.

Water that is classified as hard and very hard must be softened to avoid water heater failure.

CLASSIFICATION	MG/L OR PPM	GRAINS/GAL
Soft	0 – 17.1	0 - 1
Slightly Hard	17.1 – 60	1 – 3.5
Moderately Hard	60 – 120	3.5 – 7.0
Hard	120 – 180	7.0 – 10.5
Very Hard	180 and over	10.5 and over

If the hardness of the water exceeds the maximum level of 7 grains per gallon, water should be softened to a hardness level no lower than 5 grains per gallon. Water softened as low as 0 to 1 grain per gallon may be under-saturated with respect to calcium carbonate, resulting in water that is aggressive and corrosive.

pH of Water

pH is a measure of relative acidity, neutrality or alkalinity. Dissolved minerals and gases affect water pH. The pH scale ranges from 0 to 14. Water with a pH of 7 is considered neutral. Water with a pH lower than 7 is considered acidic. Water pH higher than 7 is considered alkaline. A neutral pH (around 7) is desirable for most potable water applications. **Corrosion damage and tank failures resulting from water pH levels of lower than 6 or higher than 8 ARE NOT covered by the warranty.** The ideal pH range for water used in a water heater is 7.2 to 7.8.

Total Dissolved Solids

Total Dissolved Solids (TDS) is a measurement of all minerals and solids dissolved in a water sample. The concentration of total dissolved solids is usually expressed in parts per million (ppm).

Water with a high TDS concentration will greatly accelerate lime and scale formation in the hot water system. Most high TDS concentrations precipitate out of the water when heated. This can generate a scale accumulation that will greatly reduce the service life of a water heater.

The manufacturer of the water heater has no control over water quality, especially TDS levels in your system. Total dissolved solids in excess of 2,000 ppm will accelerate lime and scale formation on the element or heat exchanger. Water heater failure due to total dissolved solids in excess of 2,000 ppm is a non-warrantable condition. **Failure of a water heater due to lime scale build up IS NOT covered by the warranty.**

Hardness: 7 grains

Chloride levels: 100 ppm

pH levels: 6-8

TDS: 2000 ppm

Sodium: 20 Mgl

PART 3 – HEATER PIPING

A. PLUMBING

It is mandatory that all plumbing be done in accordance with federal, local, and state plumbing codes and practices. Failure to properly install the water heater WILL VOID the warranty. It is also necessary to use both thread tape and pipe dope on all mechanical plumbing connections.

CAUTION

When filling the water heater, open a hot water tap to release air in the tank and piping. Failure to do so could lead to improper water heater operation.

CAUTION

DO NOT pipe this water heater with black iron, galvanized steel, steel, or lead pipe. Doing so will result in premature product failure and property damage, and WILL VOID the product warranty.

B. BOILER CONNECTIONS**CAUTION**

Use two wrenches when tightening water piping at heater. Use one wrench to prevent the heater return or supply line from turning. Failure to prevent piping connections from turning could cause damage to heater components.

Use a 1" nominal minimum pipe size when piping with zone valves or circulators.

On the water heater, the boiler supply connects to the outlet of the circulator. The circulator inlet is to be connected to the hot outlet side of the boiler. Be sure that the arrow on the circulator is facing the correct flow direction. (See pressure drop sizing for circulator, this manual.) On the tank, the boiler return is to be connected to the return side of the boiler. The return(s) from heating loop(s) should have a flow check or swing check valve installed before the return pipe from the tank.

In a steam boiler, the tank supply must be connected to the boiler well below the minimum water level. A strainer and drain valve should be installed at the boiler for periodic draining of scale and sludge. Banging and steam bound traps will occur if the boiler water supplied to the heat exchanger has steam or is slightly above the low water cut off.

CAUTION

Never use dielectric fittings or galvanized steel fittings on any domestic water connections. Use only copper or brass fittings. Failure to follow this caution will result in premature heater failure. Such failure is NOT covered by warranty.

C. DOMESTIC PIPING INLET

Use both thread tape and pipe dope to connect to the all stainless steel ¾" domestic inlet and outlet. A shut off valve between the city water supply and tank inlet is recommended for ease of service.

It may be recommended to use a back flow preventer – check local codes. If a back flow preventer or a no return valve is used, a thermal expansion tank must be installed on the cold water supply between the tank and valve. If the tank is replacing a tankless coil in the boiler, disconnect coil plumbing and use the cold inlet pipe and hot water outlet pipes for the water heater.

D. AUXILIARY CONNECTIONS

The auxiliary connections are additional connections for a recirculation line. These connections must be installed in accordance with all local and national codes or any applicable standard that prevails. Auxiliary connections are ¾" on all models. Never use dielectric unions or galvanized steel fittings. Use only copper or brass fittings. Sealant must be used on all connections.

 WARNING

Never connect auxiliary connections to any system that uses glycol or other solutions formulated for hydronic systems. These auxiliary connections are to be used only in a potable water system. Failure to follow this warning could result in serious injury or death.

E. FILLING THE HEATER**CAUTION**

When filling the water heater, open a hot water tap to release air in the tank and piping. The tank to ensure proper water heater operation. Failure to ensure the water heater is full before turning it on will result in damage to the water heater, and could result in property damage. Such damages ARE NOT covered by water heater warranty.

- Make certain that the field installed drain valve is completely closed.
- Open the shut-off valve in the cold water supply line.
- Open the hot water faucets to allow air to vent from the heater and piping.
- Allow sufficient time for the heater to completely fill with water.

F. TEMPERATURE AND PRESSURE RELIEF VALVE

On all models, an appropriate T&P valve must be supplied and installed as described in Figure 4.

Use both thread tape and pipe dope to install an NPT brass T&P relief valve for hot water storage tanks, as required by local codes, but not less than valves certified as meeting the requirements for relief valves for hot water heaters (ANSI Z21.22 and CAN1-4.4) by a nationally recognized lab that maintains periodic inspection of production listed equipment. Make sure the relief valve is sized to the BTU/Hour capacity and storage capacity of the water heater. The T&P relief valve must be plumbed down so discharge can exit at least 6" above the structural floor. The relief line cannot be in contact with any live electrical parts. If the relief valve constantly weeps, install an expansion tank, and see expansion tank manufacturer's instructions for suggestions.

WARNING

Do not thread a cap or plug into the relief valve under any circumstances! Explosion and property damage, serious injury, or death may result.

WARNING

To avoid water damage or scalding due to relief valve operation:

- Discharge line must be connected to relief valve outlet and run to a safe place of disposal. Terminate the discharge line in a manner that will prevent possibility of severe burns or property damage should the relief valve discharge.
- Discharge line must be as short as possible and the same size as the valve discharge connection throughout its entire length.
- Discharge line must pitch downward from the valve and terminate at least 6" above the floor drain, making discharge clearly visible.
- The discharge line shall terminate plain, not threaded, with a material serviceable for temperatures of 375°F or greater.
- Do not pipe discharge to any location where freezing could occur.
- No valve may be installed between the relief valve and heater or in the discharge line. Do not plug or place any obstruction in the discharge line.
- Test the operation of the relief valve after filling and pressurizing the system by lifting the lever. Make sure the valve discharges freely. If the valve fails to operate correctly, immediately replace with a new properly rated relief valve.
- Test T&P valve at least once annually to ensure the waterway is clear. If valve does not operate, turn the heater "off" **and call a plumber immediately.**
- Take care whenever operating relief valve to avoid scalding injury or property damage.

FAILURE TO COMPLY WITH THE ABOVE GUIDELINES COULD RESULT IN FAILURE OF RELIEF VALVE OPERATION, RESULTING IN POSSIBILITY OF SUBSTANTIAL PROPERTY DAMAGE, SEVERE PERSONAL INJURY, OR DEATH.

WARNING

RE-INSPECTION OF T&P RELIEF VALVES: T&P valves should be inspected AT LEAST ONCE EVERY THREE YEARS, and replaced, if necessary, by a licensed plumbing contractor or qualified service technician, to ensure that the product has not been affected by corrosive water conditions and to ensure that the valve and discharge line have not been altered or tampered with illegally. Certain naturally occurring conditions may corrode the valve and its components over time, rendering the valve inoperative. Such conditions can only be detected if the valve and its components are physically removed and inspected. **Do not attempt to conduct an inspection on your own.** Contact your plumbing contractor for a re-inspection to assure continued safety.

DANGER

FAILURE TO RE-INSPECT THIS VALVE AS DIRECTED COULD RESULT IN UNSAFE TEMPERATURE AND/OR PRESSURE BUILDUP WHICH CAN RESULT IN SEVERE PROPERTY DAMAGE, SERIOUS PERSONAL INJURY, OR DEATH.

G. SCALDING

WARNING

An ASSE 1017 or ASSE 1070 temperature limiting or mixing valve is recommended in installations servicing disabled or elderly persons, or children. Mixing valves do not eliminate the risk of scalding.

To avoid scalding:

- Set the water heater set point temperature as low as possible.
- Feel water before bathing or showering.
- If thermostatic valves are required, use devices specifically designed for such purpose. Install these devices in accordance with instructions provided by the manufacturer.

Failure to install a temperature limiting or mixing valve and follow these instructions could result in property damage, or severe personal injury or death due to scalds.

This water heater can deliver scalding water. Be careful whenever using hot water to avoid scalding injury. Certain appliances, such as dishwashers and automatic clothes washers may require increased water temperature. By setting the thermostat on this heater to obtain the increased water temperature required by these appliances, you may create the potential for scald injury.

APPROXIMATE TIME / TEMPERATURE RELATIONSHIPS IN SCALDS	
120°F	More than 5 minutes
125°F	1 ½ to 2 minutes
130°F	About 30 seconds
135°F	About 10 seconds
140°F	Less than 5 seconds
145°F	Less than 3 seconds
150°F	About 1 ½ seconds
155°F	About 1 second

To protect against injury, you should install a mixing valve in the water system. This valve will reduce point of discharge temperature by mixing cold and hot water in branch supply lines. Such valves are available from your local plumbing supplier.

Table 3

Table 3 details the relationship of water temperature and time with regard to scald injury and may be used as a guide in determining the safest water temperature for your applications.

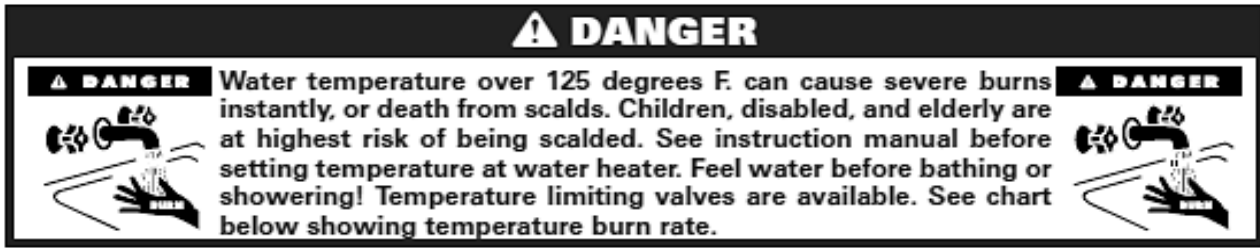

H. POTABLE EXPANSION TANK

A potable hot water expansion tank may be required to offset heated water expansion. If there is a back flow preventer or any other type of no return or check valve on the system, a thermal expansion tank is mandatory. The expansion tank must be sized for the entire water volume of the hot water system. A weeping relief valve indicates the need for an expansion tank. See Typical Expansion Tank installation, Fig. 4, for more details.

I. PRESSURE DROP SIZING FOR CIRCULATOR

The boiler circulator flow rate must meet the requirements found in Figure 1 or the published ratings cannot be achieved. The flow chart below represents the pipe run, water heater, and heat exchanger ONLY and does not include any flow checks, zone valves, or friction loss through the boiler. That resistance must be added to the value found in the chart below.

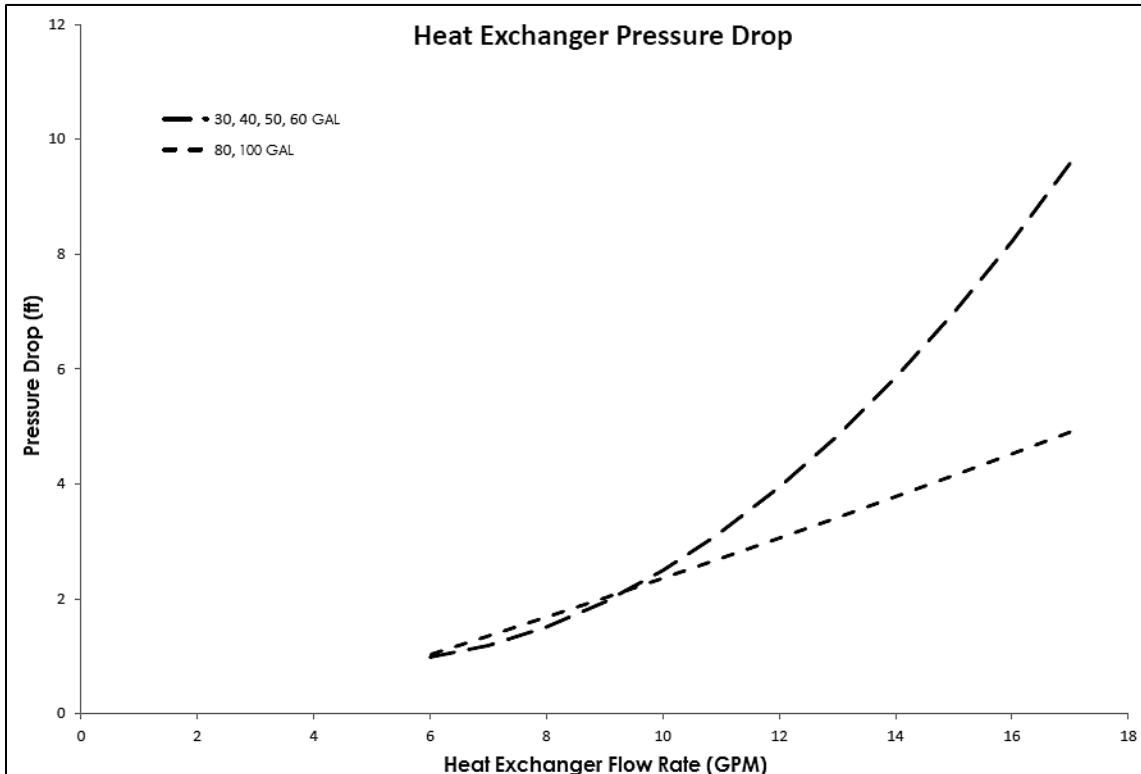

Figure 3 – Pressure Drop Through the Heat Exchanger

J. PIPING

Figure 4 – Typical Expansion Tank Application with Auxiliary Line – LP-451-A

NOTES:

1. Minimum pipe size should match connection size. Upsize pipe accordingly if greater flow is required.
2. A thermal expansion tank suitable for potable water must be sized and installed within this piping system between the backflow preventer and the cold water inlet.
3. All circulators should have an integral flow check.
4. Drains and check valve between unit and storage tank will assist in purging air from system.
5. This drawing is meant to demonstrate system piping only. The installer is responsible for all equipment and detailing required by local codes. In Massachusetts, you must install a vacuum relief valve per 248 CMR.
6. Mixing valve application is optional, but recommended to help prevent scalding. See Part 3 for more information.

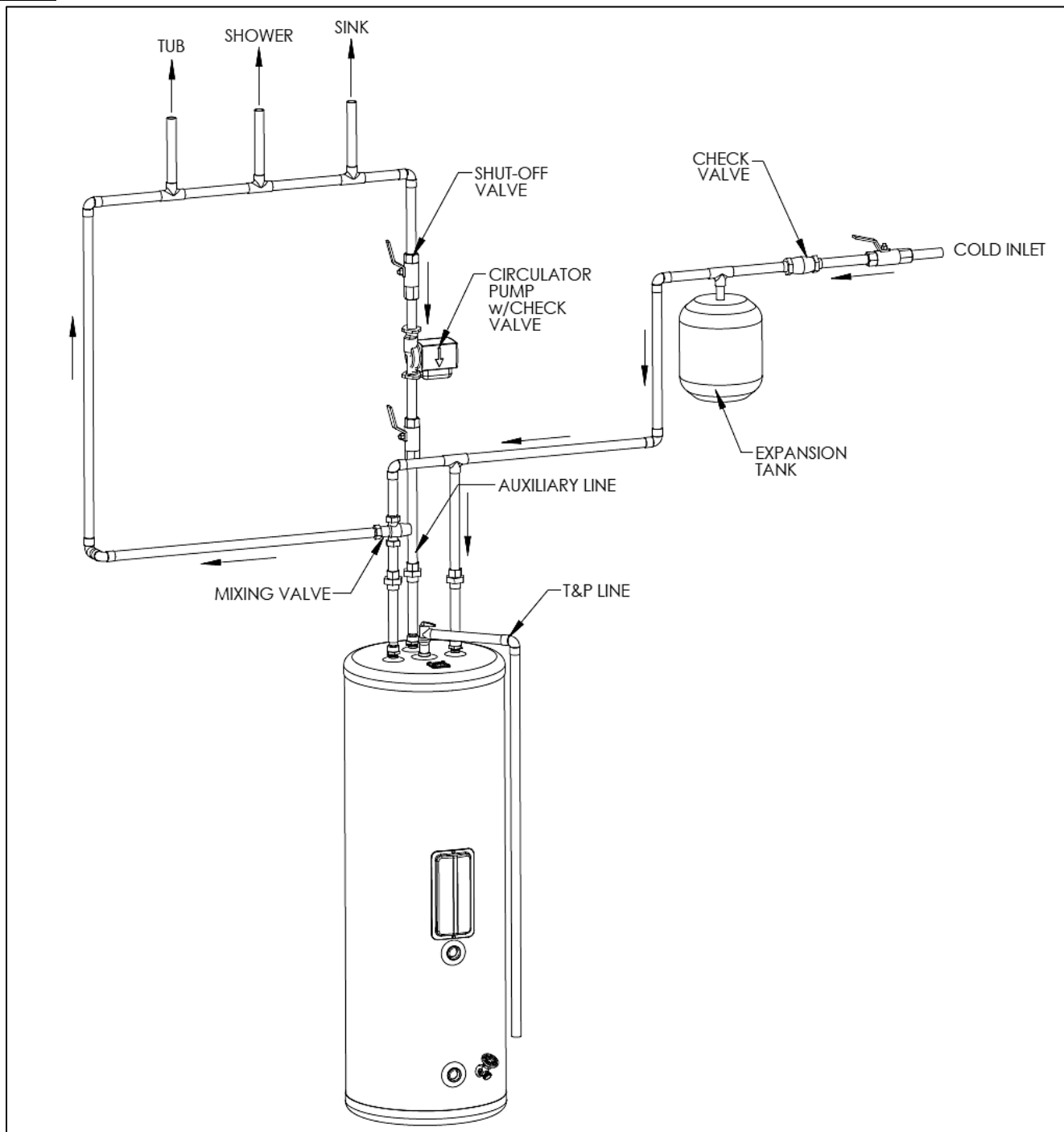
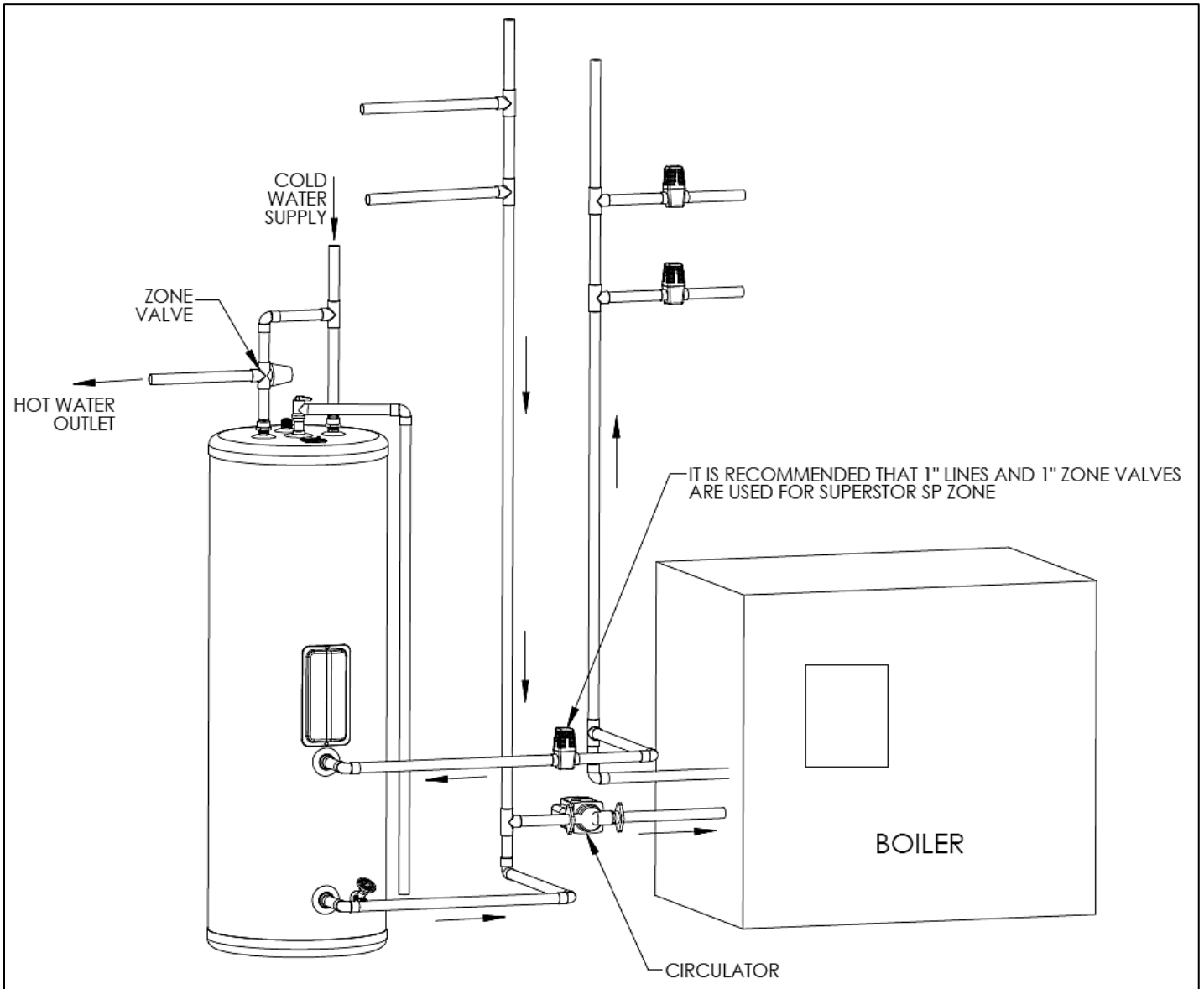

Figure 5 – Zoning with Zone Valves – LP-451-B

NOTES:

1. Minimum pipe size should match connection size. Upsize pipe accordingly if greater flow is required.
2. A thermal expansion tank suitable for potable water must be sized and installed within this piping system between the backflow preventer and the cold water inlet.
3. All circulators should have an integral flow check.
4. Drains and check valve between unit and storage tank will assist in purging air from system.
5. This drawing is meant to demonstrate system piping only. The installer is responsible for all equipment and detailing required by local codes. In Massachusetts, you must install a vacuum relief valve per 248 CMR.
6. Mixing valve application is optional, but recommended to help prevent scalding. See Part 3 for more information.

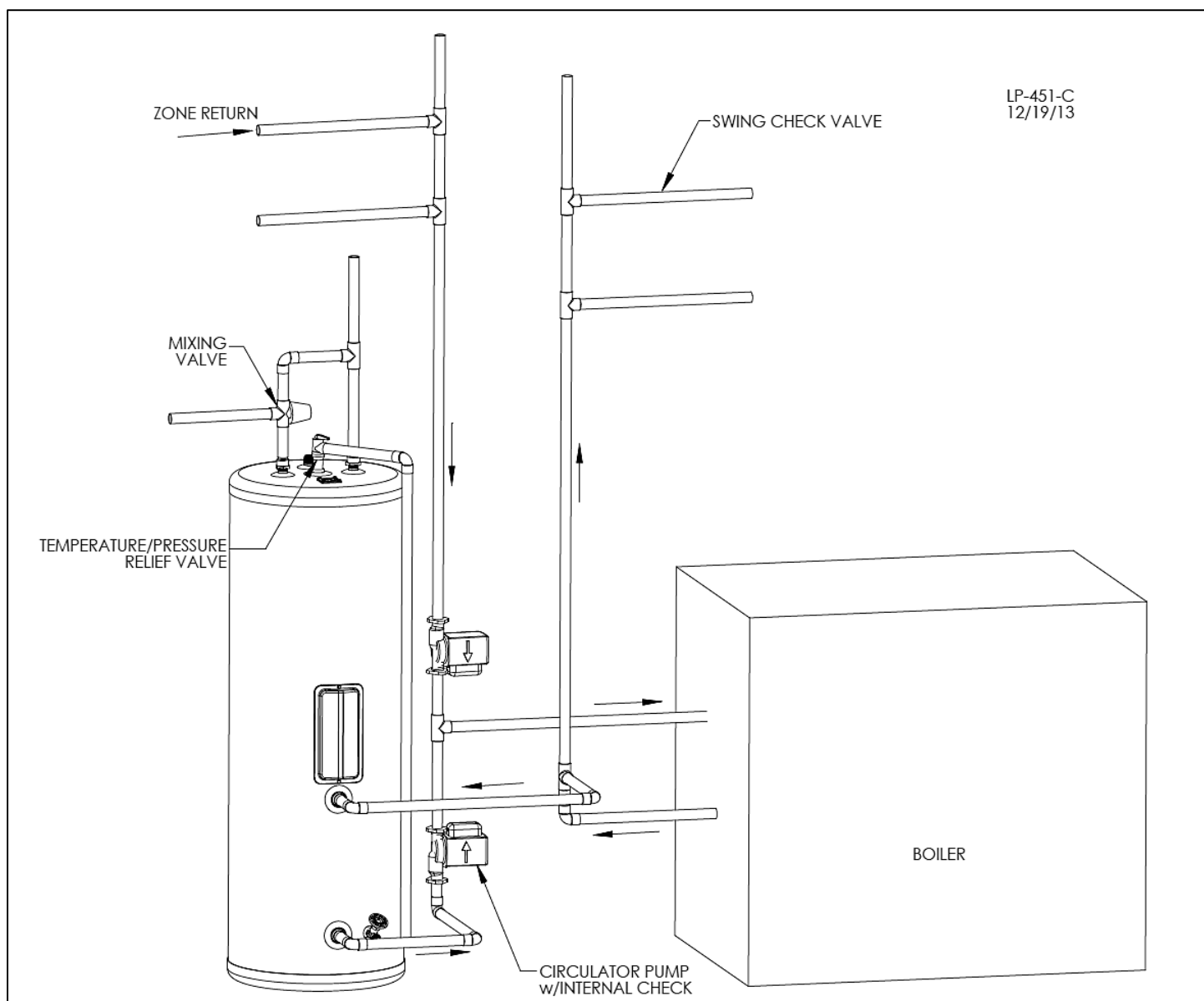

Figure 6 – Zoning with Circulators

NOTES:

1. Minimum pipe size should match connection size. Upsize pipe accordingly if greater flow is required.
2. A thermal expansion tank suitable for potable water must be sized and installed within this piping system between the backflow preventer and the cold water inlet.
3. All circulators should have an integral flow check.
4. Drains and check valve between unit and storage tank will assist in purging air from system.
5. This drawing is meant to demonstrate system piping only. The installer is responsible for all equipment and detailing required by local codes. In Massachusetts, you must install a vacuum relief valve per 248 CMR.
6. Mixing valve application is optional, but recommended to help prevent scalding. See Part 3 for more information.

PART 4 – HEATER CONTROL AND WIRING

A. CONTROL

A surface mount thermostatic control has been provided for accurate temperature adjustment.

⚠ DANGER

⚠ DANGER Water temperature over 125 degrees F. can cause severe burns instantly, or death from scalds. Children, disabled, and elderly are at highest risk of being scalded. See instruction manual before setting temperature at water heater. Feel water before bathing or showering! Temperature limiting valves are available. See chart below showing temperature burn rate.

⚠ DANGER

B. WIRING

Wiring is to be done in accordance with all applicable local and state codes. Turn off all power related to the boiler starting and wiring procedures. It is recommended that a disconnect switch be installed between the boiler control and water heater.

CAUTION

When wiring the water heater and controls, be sure to label all wires for ease of future maintenance. Wiring errors can cause improper and dangerous operation.

A thermostat connection has been provided on the top of the water heater for easy wiring and accurate control. See Figure 7. Connect the wires from the thermostat to the terminals marked + (Positive) or - (Negative).

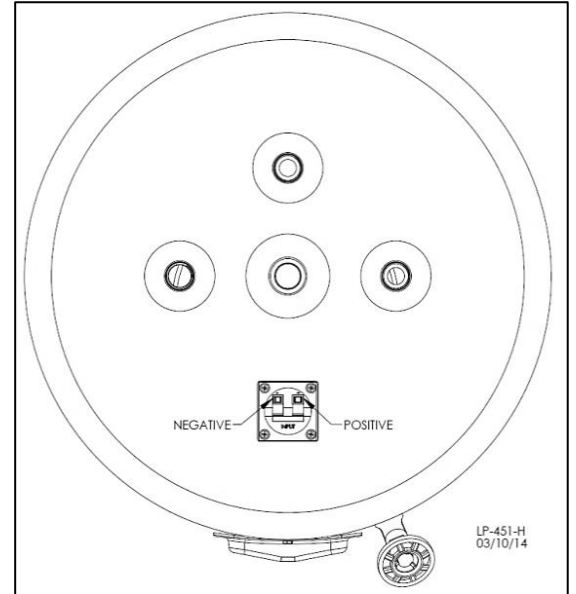

Figure 7 – Thermostat Connection

C. WIRING DIAGRAMS

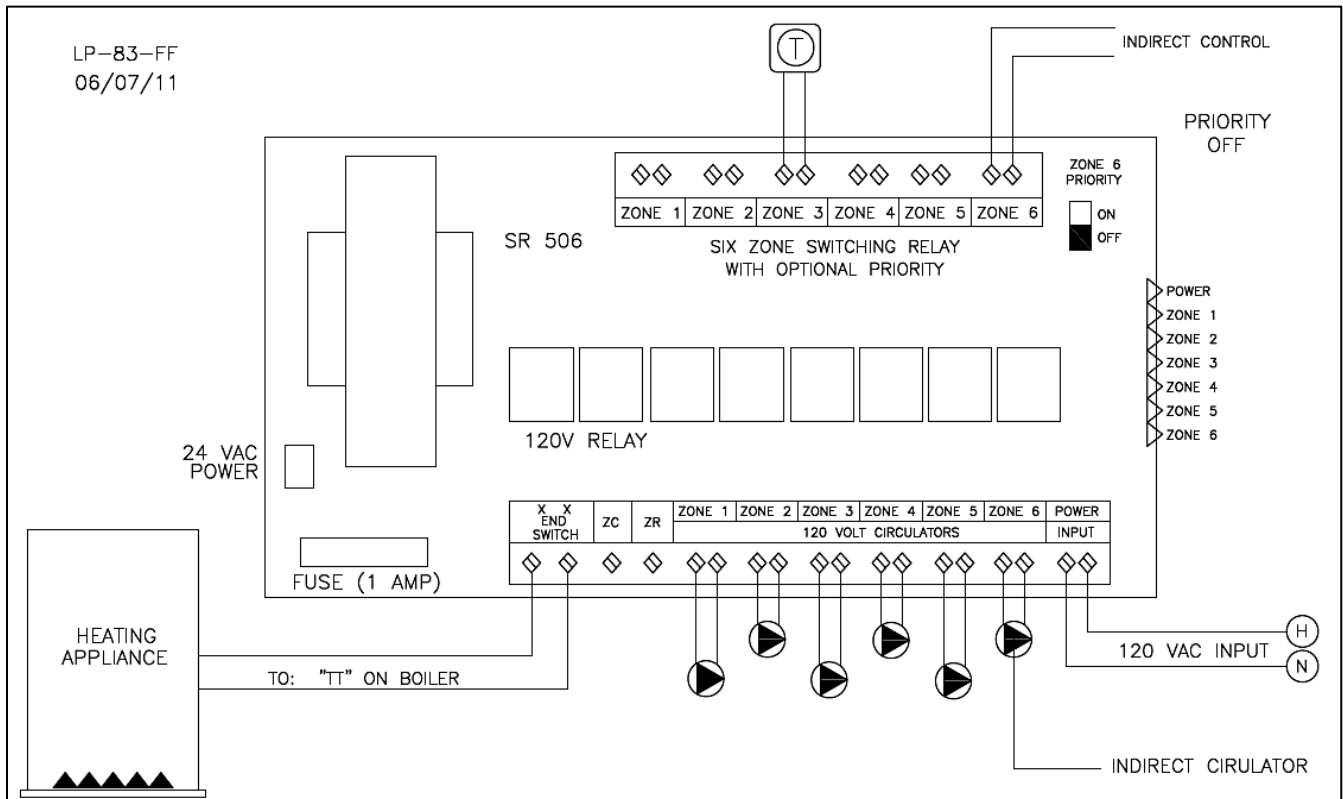

Figure 8 – Wiring with Circulators

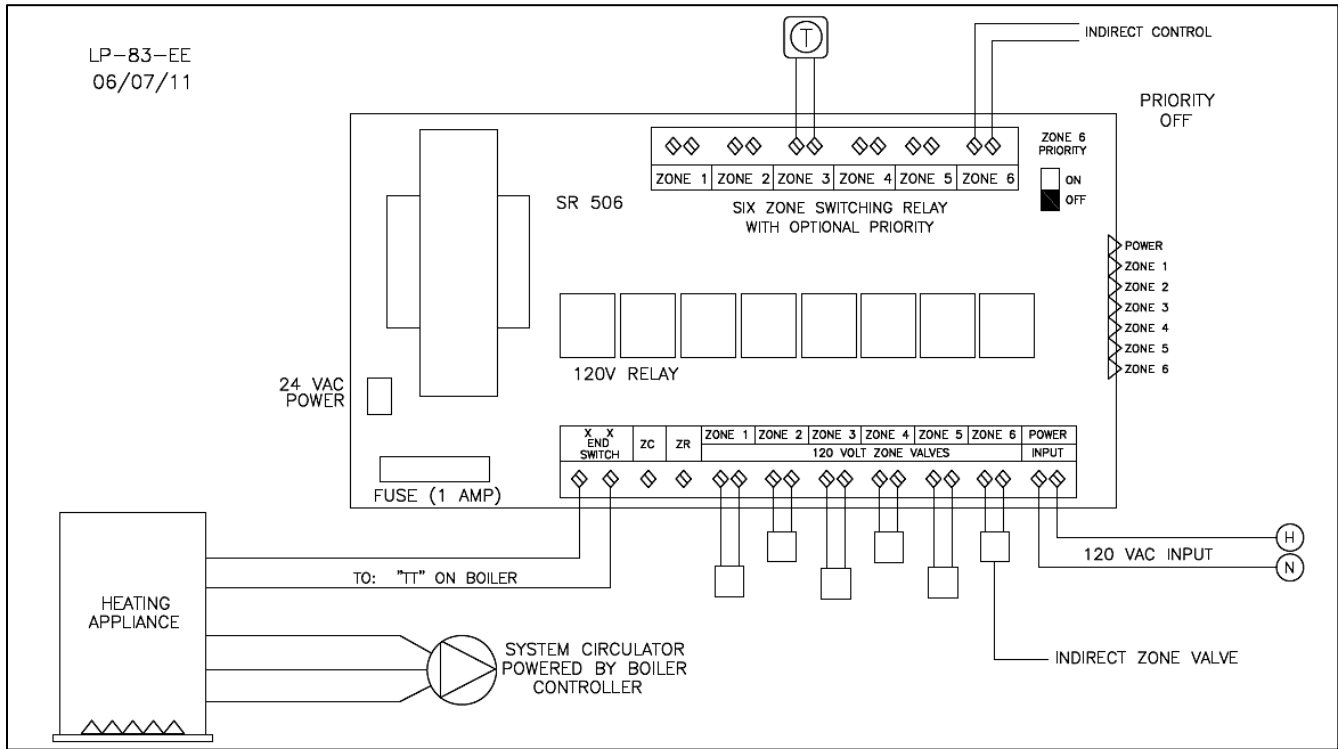

Figure 9 – Wiring with Zone Valves

PART 5 – START-UP AND OPERATION

1. Fill the water heater by opening the cold water shut-off valve. Purge air from the system by opening a hot water outlet at a fixture in a kitchen or bathroom. When water flows freely from the outlet, the system is purged.
2. Check the system for leaks.

CAUTION

Fix any leaks before continuing the installation. Any leaks can result in serious property damage and personal injury.

3. After ensuring there are no leaks within the system, flush the system to clear any soldering residue. Many soldering fluxes contain Zinc Chloride, which can corrode stainless steel.

Draw at least three times the volume of the water heater to properly flush the system.

4. Initiate a call for hot water. Ensure each zone valve or circulator operates only when its thermostat calls for heat. Purge each zone of air to ensure proper operation.
5. Set the water heater to the desired temperature. Boiler high limit should be set at least 20°F higher than the heater temperature. Set the low limit of the boiler control at the minimum setting – this will call the burner on only to satisfy the tank control.

We recommend a water heater temperature setting of 120°F. However, a lower temperature setting may be required to comply with local and state codes for normal operation. The differential should be set at 10° to 15°F. You may prefer a setting of either higher or lower water temperature. A mixing valve in conjunction with a high temperature setting may be used for high demand applications (spas, hot tubs, whirlpools).

6. When the system is completely flushed, purged of air, and the temperature is set, turn on the boiler. Observe operation. Ensure the boiler shuts down after the indirect water heater set point is satisfied.

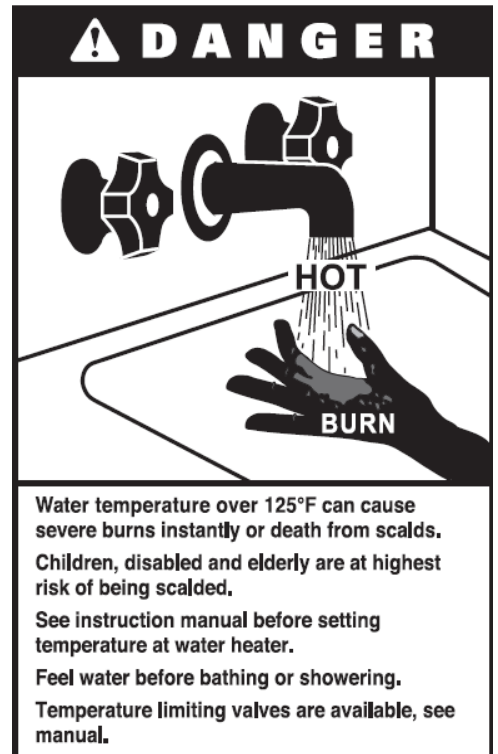

CAUTION

If draining of the heater is necessary, open the temperature and pressure valve or a hot water tap to prevent vacuum buildup in the tank and piping.

⚠ WARNING

Risk of scald injury increases as you increase water temperature.

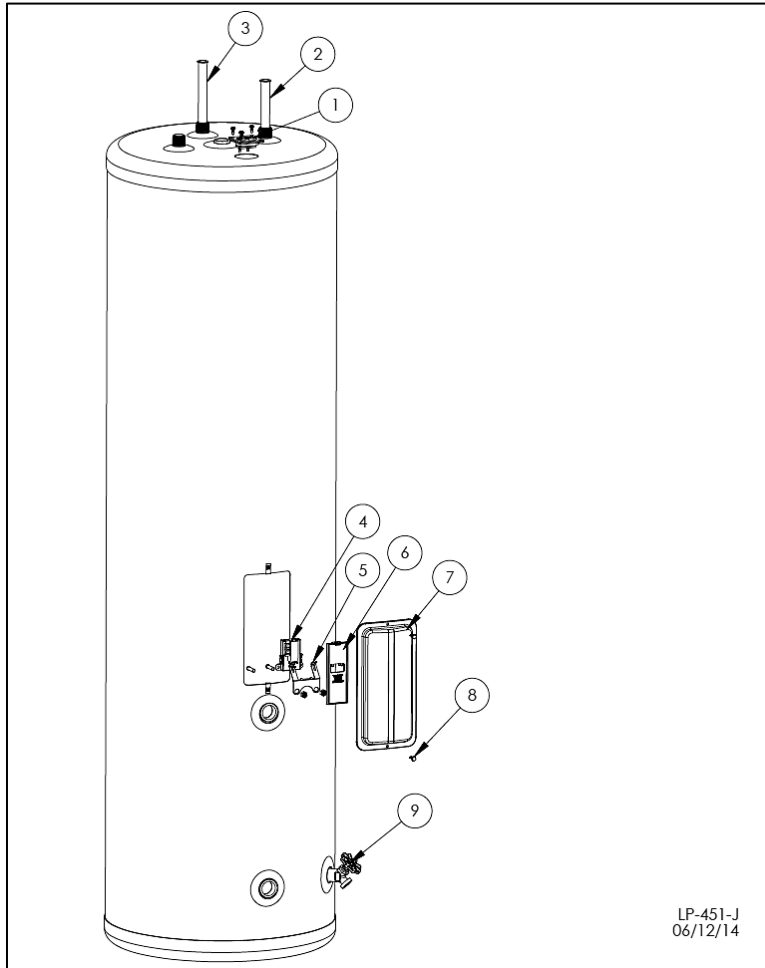

Figure 10 – Replacement Parts

ITEM #	PART #	DESCRIPTION
1	6070P-035	TERMINAL BLOCK W/ SCREWS
2	6070P-038	DIP TUBE COLD INLET – WI030
	6070P-039	DIP TUBE COLD INLET – WI040
	7700P-062	DIP TUBE COLD INLET – WI050
	6070P-041	DIP TUBE COLD INLET – WI060
	6070P-042	DIP TUBE COLD INLET – WI080 AND WI00
3	6070P-044	DIP TUBE AUXILIARY INLET – WI030
	6070P-045	DIP TUBE AUXILIARY INLET – WI040 AND WI060
	6070P-046	DIP TUBE AUXILIARY INLET – WI050
	6070P-047	DIP TUBE AUXILIARY INLET – WI080
	6070P-048	DIP TUBE AUXILIARY INLET – WI100
4	TD1012	THERMOSTAT
5	6060P-633	MOUNTING CLIP
6	6060P-634	PROTECTIVE COVER
7	H3000	ELECTRIC ACCESS PANEL
8	6075P-006	SCREWS (#8 SELF-THREADING)
9	6070P-009	COMBINATION DRAIN VALVE

Table 4 – Replacement Parts List

PART 6 – MAINTENANCE AND TROUBLESHOOTING

Periodic maintenance should be performed by a qualified service technician to assure that all the equipment is operating safely and efficiently. The owner should make necessary arrangements with a qualified heating contractor for periodic maintenance of the heater. Installer must also inform the owner that the lack of proper care and maintenance of the heater may result in a hazardous condition.

INSPECTION ACTIVITIES		DATE LAST COMPLETED			
		1 st YEAR	2 nd YEAR	3 rd YEAR	4 th YEAR*
PIPING					
Near heater piping	Check heater and system piping for any sign of leakage; make sure pipes are properly supported.				
SYSTEM					
Visual	Do a full visual inspection of all system components. Ensure all components (including boilers, water treatment systems, mixing valves, circulators, etc.) are operating properly and have been maintained.				
Functional	Test all functions of the system. Perform any maintenance required by local codes. Verify system pressure is in the safe operating range.				
Temperatures	Check control for temperature accuracy. *In installed in system - verify safe settings on Mixing Valve.				
ELECTRICAL					
Smoke and CO detector	*Verify devices are installed and working properly. Change batteries if necessary.				
Circuit Breakers	Check to see that the circuit breaker is clearly labeled. Exercise circuit breaker.				
Connections	Check wire connections. Make sure they are tight.				
RELIEF AND DRAIN VALVE					
Relief Valve	Lift and release the relief valve on the water heater. Make certain that the valve operates properly by allowing several gallons to flush through the discharge line. Replace if valve is blocked or does not operate properly. NOTE: DISCHARGED WATER MAY PRESENT A SCALD RISK. TAKE CAUTION WHEN OPERATING RELIEF VALVE.				
Drain Valve	Open the drain valve and drain a few quarts of water from the bottom of the tank to flush any hard water deposits. Replace if valve is blocked or does not operate properly. NOTE: DRAINED WATER MAY PRESENT A SCALD RISK. TAKE CAUTION WHEN OPERATING DRAIN VALVE.				
FINAL INSPECTION					
Check for combustible materials	Check area around heater for combustible materials, such as gasoline or paint thinner. If combustible materials are found, move away from the heater to a safe location.				
Check list	Verify that you have completed entire check list. WARNING: FAILURE TO DO SO COULD RESULT IN SERIOUS INJURY OR DEATH				
Homeowner	Review what you have done with the homeowner.				
INITIAL AND DATE AFTER INSPECTION/SERVICE. CONTINUE INSPECTIONS ON ANNUALLY BEYOND THE FOURTH YEAR.					

Table 5 - *If applicable to system.

TROUBLESHOOTING

NO HOT WATER

PROBLEM	POSSIBLE SOLUTION
Zone valve not opening	Open manually to replace.
Circulator not operating	Check or replace
Tank control set too low	Raise tank temperature* (SEE NOTE BELOW)
Boiler control set too low	Raise boiler temperature
Wiring incorrect	Recheck wiring
Tank control failure	Replace control
Zone valve failure	Replace valve
Circulator failure	Replace circulator
Air trap in loop	Purge air

NOT ENOUGH HOT WATER

PROBLEM	POSSIBLE SOLUTION
Zone valve restriction	1" full bore replace zone valve
Circulator arrow reversed	Reverse circulator
Tank temperature too low	Raise tank temperature* (SEE NOTE BELOW)
Boiler temperature too low	Raise boiler temperature
Boiler sized too small	Check sizing chart
Tank sized too small	Check sizing chart
Demand flow rate too high	Install mixing valve, raise tank temperature*
Air trap in loop	Purge to remove air Install flow regulator
Heat and tank come on together	Recheck wiring or set indirect as priority over central heating. Draw tank down and lower thermostat. Recheck.
Not enough space heat	Boiler sized too small. Consult chart.
Slow recovery	Circulator head capacity too low

T & P VALVE DISCHARGES

PROBLEM	POSSIBLE SOLUTION
Tank temperature too high	Lower temperature on tank
Water expands when heated	Install expansion tank
Water pressure too high	Install pressure reducing valve

HOT TUBS, SPAS, MULTIPLE SHOWERS, HIGH DEMAND

PROBLEM	POSSIBLE SOLUTION
Pressure too low	Check line pressure for restriction
Recovery of tank slow	Slow startup boiler. See chart. Boiler sized too small. See chart.
Not enough hot water	Check flow rate and compare to chart Demand too great. Check flow rates and compare to chart. Install mixing valve and/or flow restricting valve and raise tank and boiler temperature*.

Table 6 - *See scald warning below.

⚠ WARNING

When raising tank temperature, the risk of scald injury increases. To avoid scald injury, use a water tempering or mixing valve and extreme caution when using hot water. Consult codes for conformance.

⚠ DANGER



Water temperature over 125 degrees F. can cause severe burns instantly, or death from scalds. Children, disabled, and elderly are at highest risk of being scalded. See instruction manual before setting temperature at water heater. Feel water before bathing or showering! Temperature limiting valves are available. See chart below showing temperature burn rate.



CUSTOMER INSTALLATION RECORD FORM

The following form should be completed by the installer for you to keep as a record of the installation in case of a warranty claim. After reading the important notes at the bottom of the page, please also sign this document.

Customer's Name:	
Installation Address:	
Date of Installation:	
Installer's Code/Name:	
Product Serial Number(s):	
Comments:	
Installer's Phone Number:	
Signed by Installer:	
Signed by Customer:	

IMPORTANT:

Customer: Please only sign after the installer has reviewed the installation, safety, proper operation, and maintenance of the system. In the case that the system has any problems, please call the installer. If you are unable to make contact, please contact your Westinghouse Sales Representative.

Distributor/Dealer: Please insert contact details.

® WESTINGHOUSE are trademarks of Westinghouse Electric Corporation. Used under license by HTP, Inc All Rights Reserved.