



# User's Manual

**UPRIGHT FREEZER**    **WHS-502FWEW1(E)**  
**WHS-502FWEB1(E)**  
**WHS-502FWESS1(E)**

Before using your product, please read this manual carefully and keep it for future reference.



# TABLE OF CONTENTS

---

NAMES OF THE PARTS.....	2
IMPORTANT SAFETY INSTRUCTIONS.....	3
INSTALLATION INSTRUCTION	
BEFORE USING YOUR FREEZER .....	3
INSTALLING YOUR FREEZER.....	3
ELECTRICAL CONNECTION.....	4
OPERATING YOUR FREEZER	
TEMPERATURE CONTROL.....	5
DEFROSTING.....	5
STORAGE OF FROZEN FOODS.....	5
CARE AND MAINTENANCE	
CLEANING YOUR FREEZER.....	6
VACATION TIME.....	6
MOVING YOUR FREEZER.....	6
ENERGY SAVING TIPS.....	6
TROUBLESHOOTING GUIDE.....	7

# NAMES OF THE PARTS

---

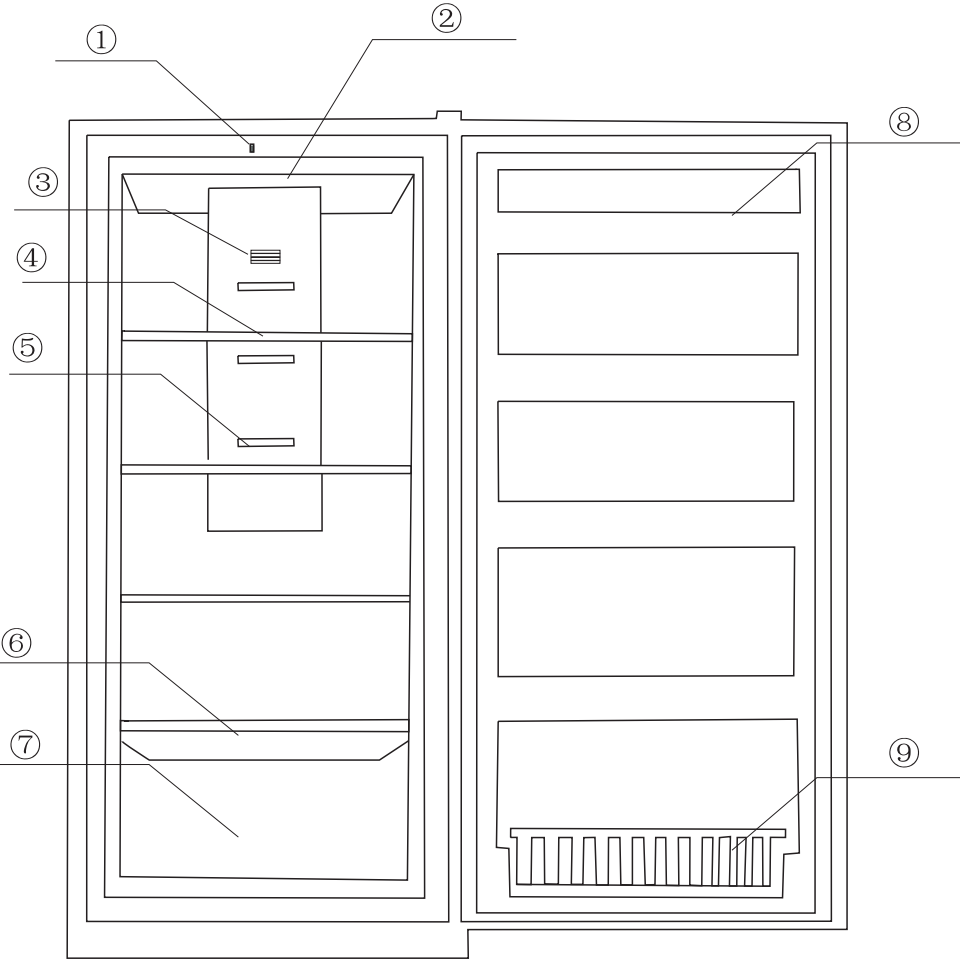

- 1.Lamp switch
- 2.Lamp cover
- 3.Temperature sensor
- 4.Wire shelf
- 5.Airflow outlet

- 6.Airflow inlet
- 7.Wire drawer
- 8.Door tray
- 9.Wire door tray

✔ **WARNING** ✔ : Never touch the interior of the Freezer Chamber or frozen foods in the compartment with wet hands as this could result in injury.

# IMPORTANT SAFETY INSTRUCTIONS

<b>⚡ WARNING ⚡</b>	To reduce the risk of fire, electrical shock, or injury when using your freezer, follow these basic precautions:
<ul style="list-style-type: none"><li>• Read all instructions before using the freezer.</li><li>• <b>DANGER or WARNING:</b> Risk of child entrapment.</li><li>• To avoid the possibility of child entrapment, please take the following precautions before disposing your freezer.<ul style="list-style-type: none"><li>- Remove all doors from the unit.</li><li>- Leave the shelves in place so that children may not easily climb inside.</li></ul></li><li>• Never allow children to operate, play with, or crawl inside the freezer.</li><li>• <b>Refrigerants:</b> All refrigeration products contain refrigerants, which under the guidelines of federal law must be removed before disposal of product. It is the consumer's responsibility to comply with federal and local regulations when disposing of this product.</li><li>• Never clean freezer parts with flammable fluids. The fumes can create a fire hazard or explosion.</li><li>• Do not store or use gasoline or any other flammable vapors and liquids in the vicinity of this or any other freezer. The fumes can create a fire hazard or an explosion.</li></ul> <p style="text-align: center;"><b>-Save these instructions-</b></p>	

## INSTALLATION INSTRUCTIONS

### Before Using Your Freezer

- Remove the exterior and interior packing.
- Before connecting the freezer to the power source, let it stand upright for approximately 4 hours. This will reduce the possibility of a malfunction in the cooling system from improper handling during transportation.
- Clean the interior surface with lukewarm water using a soft cloth. (Cleaning instruction on page 6)

### Installing Your Freezer

- This appliance is designed to be free standing only, and should not be recessed or built-in.
- Place your freezer on a floor that is strong enough to support the freezer when it is fully loaded.
- Allow 5 inches of space between the back and sides of the freezer, which allows the proper air ventilation. Adjust the feet to keep the freezer level.
- Locate the freezer away from direct sunlight and sources of heat (stove, heater, radiator, etc.). Direct sunlight may affect the acrylic coating and heat sources may increase electrical consumption. Ambient temperature below 50°F (10°C) or above 85°F (29°C) will hinder the performance of this appliance. **This unit is not designed for use in a garage or any other outside installation.**
- Avoid locating the freezer in moist areas.
- Plug the freezer into dedicated, properly installed-grounded wall outlet. Do not under any circumstances cut or remove the third (ground) prong from the power cord. Any questions concerning power and/or grounding should be directed toward a certified electrician or an authorized service center. **This unit is not designed to be installed in an RV or used with an inverter.**
- After plugging the appliance into a wall outlet, turn the unit on and allow the unit to cool down for 2~3 hours before placing food in the freezer compartment.
- This unit is designed for in-home use only. Not designed for medical applications.

## Electrical Connection

### ⚠ WARNING ⚠

Improper use of the grounded plug can result in the risk of electrical shock. If the power cord is damaged, have it replaced by an authorized service center.

This freezer should be properly grounded for your safety. The power cord of this freezer is equipped with a three-prong plug which mates with standard three prong wall outlets to minimize the possibility of electrical shock.

Do not, under any circumstances, cut or remove the third ground prong from the power cord supplied.

This freezer requires a standard 115/120 Volt A.C. ~/60Hz electrical outlet with three-prong ground.

This freezer is not designed to be used with an inverter.

The cord should be secured behind the freezer and not left exposed or dangling to prevent accidental injury.

Never unplug the freezer by pulling the power cord. Always grip the plug firmly and pull straight out from the receptacle.

Do not use an extension cord with this appliance. If the power cord is too short, have a qualified electrician or service technician install an outlet near the appliance. Use of an extension cord can negatively affect the performance of the unit.

# OPERATING YOUR FREEZER

## Temperature Control

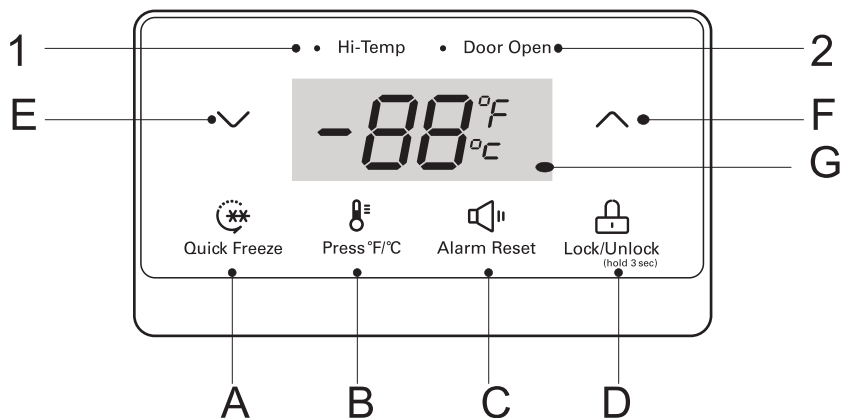

### Alarm lamps

1. Hi-Temp (High temperature alarm)
2. Door Open (Door keep open for 60 seconds alarm )

### Buttons

- A. Quick Freeze button      B. °C or °F temperature switch button  
C. Alarm Reset button      D. Lock / Unlock button  
E. Temperature setting / Quick Freeze time setting (v) down  
F. Temperature setting / Quick Freeze time setting (^) up

### Functions

#### Freezer temperature setting

Press buttons E (temperature down) or F (temperature up) to set the freezer temperature.

The temperature display G will blink. Set the temperature range from 7°F to -8°F-14°C to -22°C).

Once the temperature is selected, press button D to set and exit. The temperature setting mode will exit automatically after 10 seconds if no buttons are pressed

#### Quick Freeze Function setting

Press button A to start Quick Freeze. The temperature display will read "-11°F" or "-24°C" and the Quick Freeze duration time is 6 hours. To stop Quick Freeze press button A again.

To change the Quick Freeze duration time, press and hold button A for 3 seconds until the time display starts to blink to enter Quick Freeze time setting. Press buttons E or F to select the Quick Freeze duration time of 6 hours or 48 hours. Press button D to set and exit. The time duration setting mode will exit automatically after 10 seconds if no buttons are pressed.

For energy savings, the manufacturer recommends the 6 hours setting.

# CARE AND MAINTENANCE

## Cleaning Your Freezer

- Upon installation of your new appliance, it is recommended that it be cleaned thoroughly.
- Turn off the freezer first and then unplug the unit from the wall outlet.
- Remove all food contents.
- Wash the inside with a damp warm cloth soaked in lukewarm water and baking soda solution. The solution should be about 2 tablespoons of baking soda to a quart of water.
- Be sure to keep the door gasket (seal) clean to keep the unit running efficiently.
- The outside of the freezer should be cleaned with mild detergent and warm water.
- Dry the interior and exterior with a soft cloth.

## Vacation Time

- Turn off the freezer first and then unplug the unit from the wall outlet.
- Remove all the food.
- Clean the freezer.
- Leave the door open slightly to avoid possible formation of condensation, mold, or odors.
- Use extreme caution in the case of children. The unit should not be accessible to child's play.
- **Short vacations:** Leave the freezer operating during vacations of less than three weeks.
- **Long vacations:** If the appliance will not be used for several months, remove all food and unplug the power cord. Clean and dry the interior thoroughly. To prevent odor and mold growth, leave the door open slightly: blocking it open if necessary or have the door removed.

## Moving Your Freezer

- Turn off the freezer first and then unplug the unit from the wall outlet.
- Remove all the food.
- Securely tape down all loose items inside your freezer.
- Tape the doors shut.
- Be sure the freezer stays in the upright position during transportation.
- Let the unit stand in the upright position for approximately 4 hours prior to restarting the unit.

## Energy Saving Tips

- The freezer should be located in the coolest area of the room, away from heat producing appliances or heating ducts, and out of the direct sunlight.
- Let hot foods cool to room temperature before placing in the freezer. Overloading the freezer forces the compressor to run longer. Foods that freeze too slowly may lose quality, or spoil.
- Be sure to wrap foods properly, and wipe containers dry before placing them in the freezer. This cuts down on frost build-up inside the freezer.
- Organize and label food to reduce door openings and extended searches. Remove as many items as needed at one time, and close the door as soon as possible.

# TROUBLESHOOTING GUIDE

You can solve many common freezer problems easily, saving you the cost of a possible service call. Try the suggestions below to see if you can solve the problem before calling for service.

PROBLEM	POSSIBLE CAUSE
Freezer does not operate.	Not plugged in. The circuit breaker tripped or a blown fuse.
Compressor turns on and off frequently.	The room temperature is hotter than normal. A large amount of food has been added to the freezer. The door is opened too often. The door is not closed completely. The temperature control is not set correctly. The door gasket does not seal properly. The freezer does not have the correct clearances. The freezer has recently been disconnected for a period of time. 4 hours are required for the freezer to cool down completely.
Temperature inside the freezer is too warm.	Temperature control is set too warm. Turn the control to a cooler setting and allow several hours for the temperature to stabilize. Door is kept open too long or is opened too frequently. Warm air enters the freezer every time the door is opened. Open the door less often. The door is not closed completely. The door gasket does not seal properly. A large amount of warm or hot food might have been stored recently. Wait until the freezer has had a chance to reach its selected temperature. The freezer has recently been disconnected for a period of time. 4 hours are required for the freezer to cool down completely.
Temperature inside the freezer is too cold.	Temperature control is set too cold. Turn the control to a warmer setting and allow several hours for the temperature to stabilize.
Temperature of external freezer surface is warm.	The exterior freezer walls can be as much as 30°F warmer than room temperature. This is normal while the compressor works to transfer heat from inside the freezer cabinet.
Popping or cracking sound when compressor comes on.	Metal parts undergo expansion and contraction, as in hot water pipes. This is normal. Sound will level off or disappear as freezer continues to run.
Bubbling or gurgling sound, like water boiling.	Refrigerant (used to cool freezer) is circulating throughout the system. This is normal.
Vibrations.	Check to assure that the freezer is on a level surface. Floor is uneven or weak. Freezer rocks on the floor when it is moved slightly. Be sure floor can adequately support freezer. Level the freezer by putting wood or metal shims under part of the freezer. The freezer is touching the wall. Re-level the freezer and move it from the wall. See "Installation Instructions".
Moisture forms on inside freezer walls.	Weather is hot and humid, which increases internal rate of frost build-up. This is normal. Door is slightly open. Door is kept open too long, or is opened too frequently. Open the door less often. The door is not sealed properly.
Moisture forms on outside of freezer.	Door is slightly open, causing cold air from inside the freezer to meet warm moist air from outside.
The door will not close properly.	The freezer is not on a level surface. The gasket is dirty.



For more information, please visit our website  
[www.midea.com](http://www.midea.com)

