

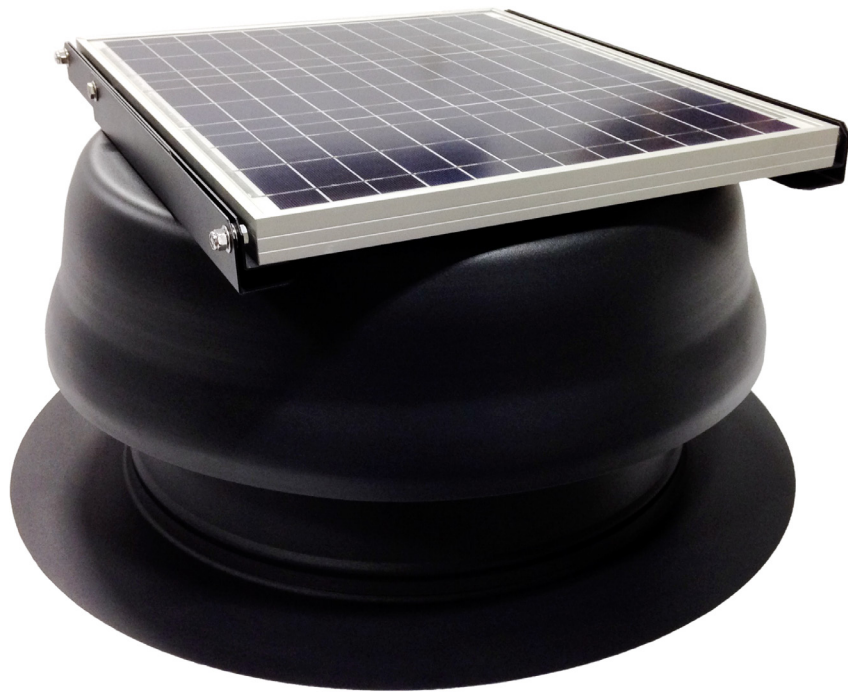

Installation Guide



CV-2000
CV-3000



ATTENTION: PLEASE READ THROUGH THIS ENTIRE INSTRUCTION GUIDE BEFORE PROCEEDING WITH YOUR INSTALLATION. MAKE SURE YOU HAVE THE REQUIRED TOOLS AND MATERIALS TO COMPLETE THE INSTALLATION OF YOUR SOLAR ATTIC FAN BEFORE BEGINNING.

Getting Started

Your Cardinal Ventilation solar attic fan is designed for easy installation with composite shingle roofs or other low-profile roofing materials which may accommodate self-flashing roofing products. For installation of our products on metal or tile roofs, please contact Cardinal Ventilation for information about our Curb-Mount Adapter Kits designed for these roof types.



Your local building code may require specific fasteners or anchoring systems not discussed in this installation guide. If installing this product in an area of either Florida or Texas that has been designated as a high velocity wind zone area, review applicable building code requirements for additional installation instructions.

What's Needed



Cordless Drill with Nut Driver



Weatherproof Roofing Grade Sealant



Self-Tapping Screws with Rubber Bonded Washers



Roofing Knife



Reciprocating Saw



Ladder



Measuring Tape



Marker or Carpenter Pencil

Safety Information

Safety precautions should be taken when performing the roofing work described in this installation guide. You can significantly reduce your risk of danger by following the below recommendations:

- Do not perform roofing work in wet or windy conditions
- Tie-off both yourself and your equipment when working on steep pitched roofs to avoid falls
- Wear safety glasses and protective gloves when using power tools
- Always wear slip-resistant shoes when working on the roof
- Do not cut through any rafters or structural members of the roof during installation
- Leave the solar panel covered until your installation is complete

Choosing the Right Location

Choose a location to install your solar attic fan that allows for balanced air flow throughout the attic space. The solar fan should be installed roughly centered on the roof and three feet below the ridge line. For optimum performance, choose an area on the south side of your roof that is not shaded or blocked from the sun for extended periods throughout the day. If a location on the southern side of your roof is not available, you may raise the solar panel mounting bracket and face the fan unit toward the south for better sun exposure. Your solar attic fan should not be installed any closer than within 10 feet to an existing passive vent, ridge vent, or additional fan unit.

Ventilation Requirements

In order for your Cardinal Ventilation solar attic fan to operate at maximum performance, your attic must have enough intake ventilation (net free area) to support the amount of air that your fan is moving. We recommend a minimum of 5.5 square feet of net free area intake ventilation for best performance.

Installing the Fan

Step 1 - Cut the Hole

After choosing the location where your solar attic fan will be installed, find the closest rafter to that location and determine if your roof has either 16" on center or 24" on center rafter spacing. If your roof has 24" on center rafter spacing, find the center point between two rafters and mark it as the center of the vent hole. For roofs with 16" on center spacing, mark the rafter itself as the center of the vent hole. Partially insert a screw into the center point mark. Using the screw as a reference point, trace out a 10" radius circle (20" across) as shown in Figure 1. Next, use a reciprocating saw to cut out the traced hole pattern from the roof decking. Remove the cut out decking material from around the hole as needed.

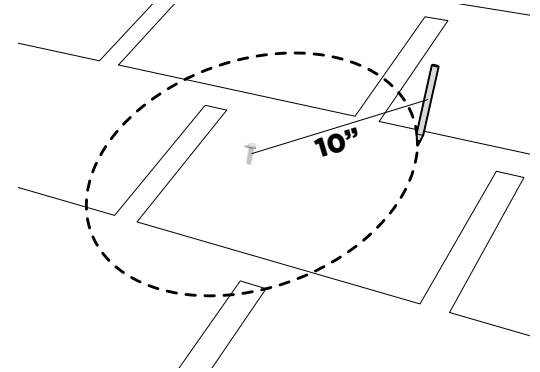

ATTENTION: DO NOT CUT THROUGH ANY RAFTERS OR STRUCTURAL MEMBERS WHILE CUTTING THE VENT HOLE. ONLY CUT OUT THE ROOF DECKING.

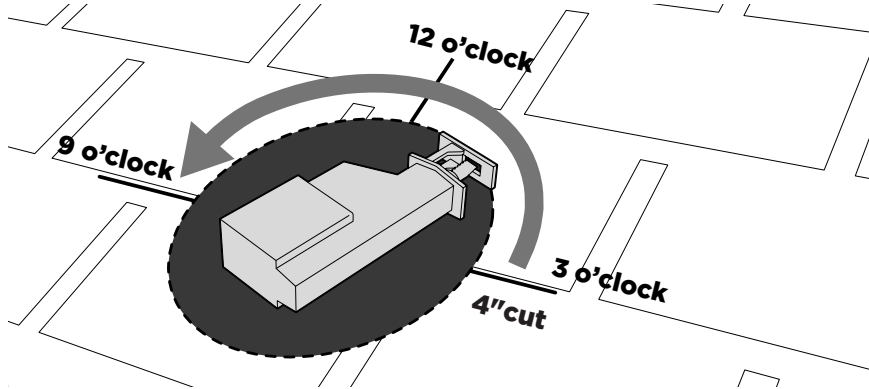

Figure 2 - Releasing the Shingles

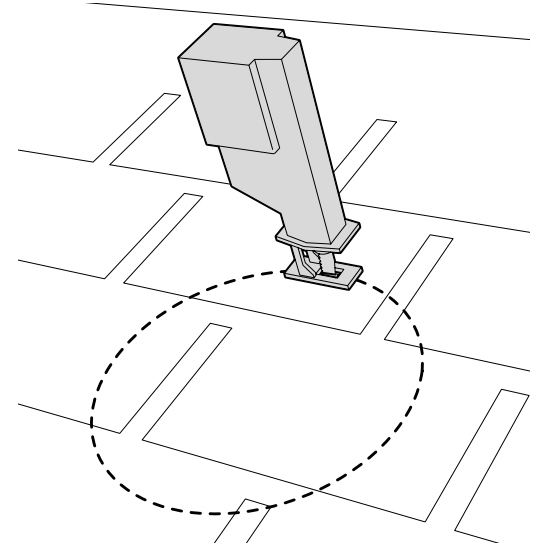

Figure 1 - Cutting the Hole

Step 2 - Release the Shingles

Insert the reciprocating saw sideways between the shingles and roof decking. Starting at the 3 o'clock position of the vent hole, begin cutting in a sweeping motion under the shingles, sawing through any roofing nails or staples. Continue cutting counter-clockwise around the vent hole until reaching the 9 o'clock position. Using a roofing knife, cut a 4 inch horizontal slit in the shingles at the 9 o'clock and 3 o'clock positions of the hole, allowing the fan's flashing to slide underneath the shingles.

Step 3 - Mount the Fan

Apply weatherproof caulking to the bottom side of the fan unit (see Figure 3). Align the fan unit with the vent hole so that the sticker "solar panel pivot's this way" is facing the desired direction. If the solar panel is to remain in the flat unraised position, the sticker will be on the topside (12 o'clock position) of the fan unit.

Next, slide the fan underneath the shingles until the fan reaches the top of the vent hole. Secure the fan flashing to the roof with self-tapping screws through the pre-drilled holes in the base flashing. Apply caulk around the fan unit where the shingles meet the flashing, across the 4" slit cuts, and over any exposed screw heads to weatherproof your installation.

Remove the cardboard cover from the solar panel and your solar attic fan should begin working.

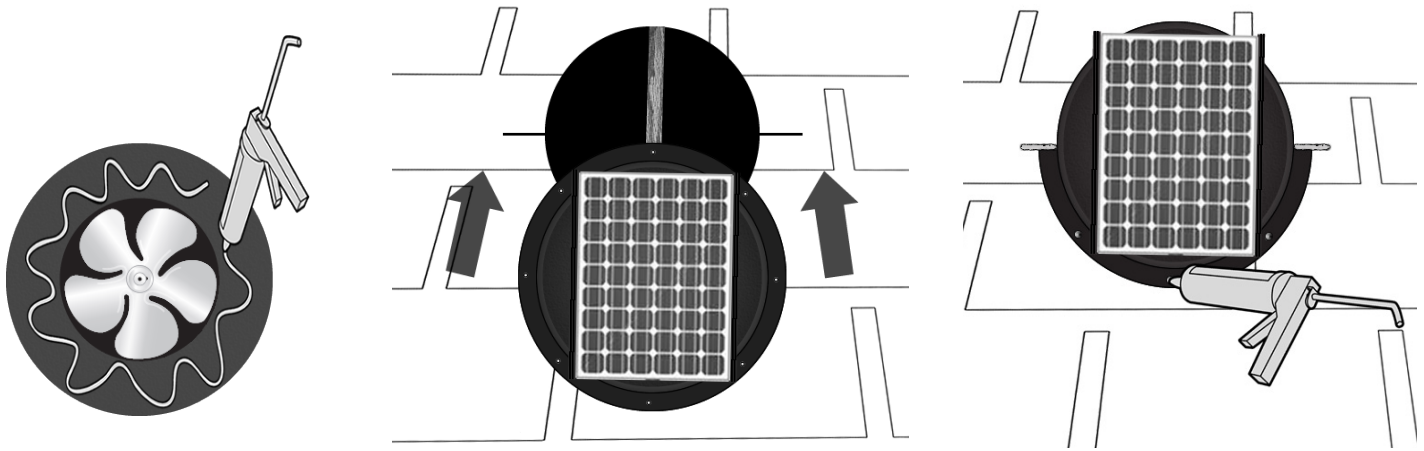

Figure 3 - Mounting the Fan

Adjusting the Solar Panel

The solar panel on your Cardinal Ventilation solar attic fan may either be left down in the horizontal mounted position as received from the factory, or the solar panel bracket may be raised to pivot the solar panel toward the south in order to get better sun exposure. To raise the solar panel, first remove the set bolts from the solar panel mounting brackets as shown in Figure 4. You will need 7/16" wrench and a pair of pliers to remove the set bolts and lock nuts.

Once the set bolts are removed, raise the solar panel and fold out the bracket legs. Align the mounting holes in the bracket legs with those on the base brackets. Insert the set bolt and washer through the mounting holes in the brackets and secure each in place with a lock nut.

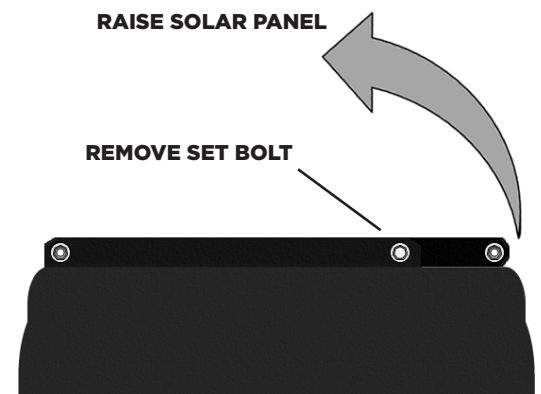

Figure 4 - Adjusting the Solar Panel



Do not raise the solar panel if installing this product in an area of either Florida or Texas that has been designated as a high velocity wind zone area. The solar panel must remain in the flat horizontal position due to building code requirements.

Warranty Registration

Cardinal Ventilation offers an industry leading 25-year standard parts warranty on your new solar attic fan. For more information about the terms and conditions of our warranty, please see our website for details.



YOUR WARRANTY MUST BE REGISTERED WITHIN 90 DAYS OF INSTALLATION. Please visit our website at www.cardinalventilation.com to register your warranty.