

CATSKILL

C R A F T S M E N , I N C .

Assembly Instructions Model 1480DOR

Empire Island



GENERAL:

1. You have purchased model 1480DOR.
2. Should you need assistance or need to replace a damaged or missing part simply give us a call M-F at 607-652-7321 from 7:30 am - 4:30 pm Eastern and we'll send you the prepaid part via UPS usually that same day! You may also email us: info@catskillcraftsmen.com.
3. Read the assembly instructions and the enclosed brochure before beginning assembly. Assembly is easy if you read and follow the instructions step by step. See our website for assembly tips and videos: www.catskillcraftsmen.com
4. The only tools needed are a hammer, a small and a medium Phillips head screwdriver and a medium flat blade screwdriver. A pencil is also needed. A power screwdriver will speed assembly, but is not required. Place a few drops of vegetable oil on the threads of wood screws before screwing into the solid hardwood parts.
5. Glides are sometimes pre-packed with screws. These are not used.
6. Instructions (left/right, top/bottom) are given as you face an assembled unit.

CABINET PARTS

Not To Scale

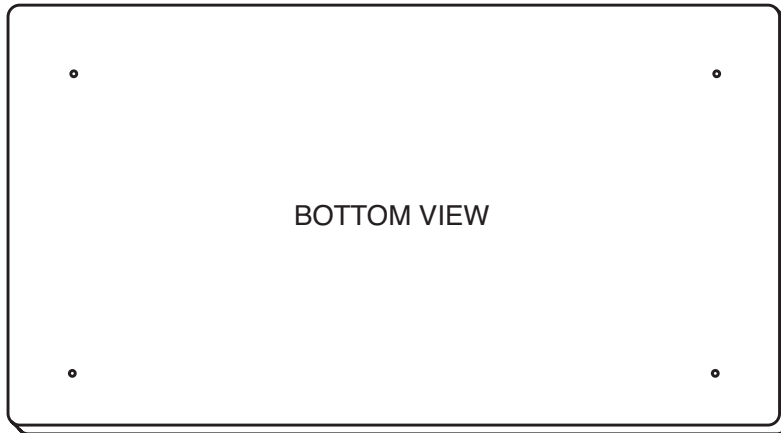

(1) Table Top-1480
44" x 26" x 1 1/4"

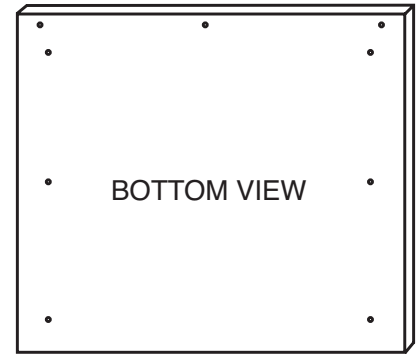

(2) Pull Out Cutting Board Tops
22" x 19 1/2" x 3/4"

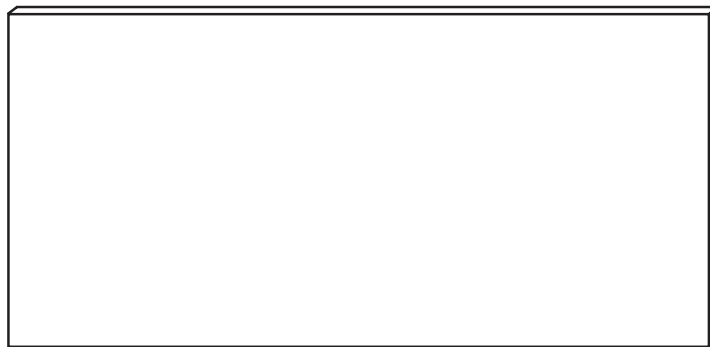

(1) Bottom Shelf-1480
39 3/16" x 22 1/8" x 7/16"

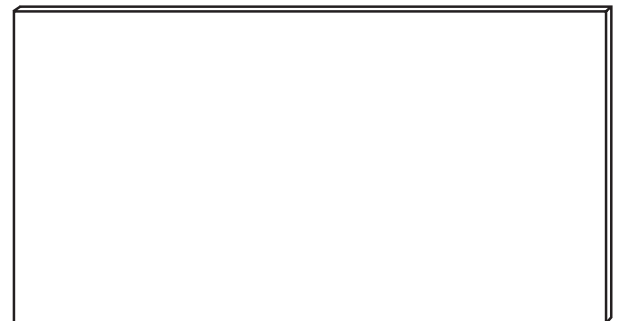

(1) Drawer Bottom-1480
31 9/16" x 21 3/4" x 1/4"



(1) Middle Shelf-1480DOR (Edge Banded)
39 3/16" x 21 7/16" x 7/16"

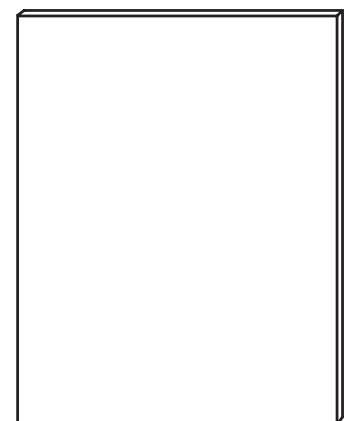

(2) Side Panel Inserts-1480
20 9/16" x 22 11/16" x 1/4"



(2) Right Leg-1480DOR
32 1/2" x 4" x 7/8"
(Inside View)

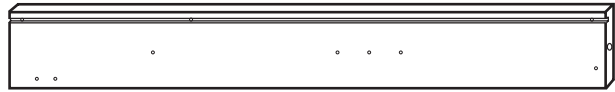

(2) Left Leg-1480DOR
32 1/2" x 4" x 7/8"
(Inside View)

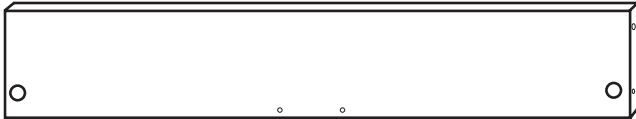

(1) Top Back Brace-1480DOR
33 7/16" x 7 3/8" x 3/4"
(Inside View)



(1) Top Front Brace-1480DOR
33 7/16" x 2" x 3/4"
(Inside View)

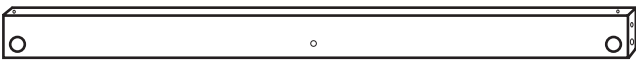

(2) Front/Back Bottom Brace-1480DOR
33 7/16" x 2" x 3/4"
(Inside View)



(1) Left Drawer Side-1480DOR
21 1/4" x 4 3/8" x 3/4"
(Outside View)



(1) Right Drawer Side-1480DOR
21 1/4" x 4 3/8" x 3/4"
(Inside View)

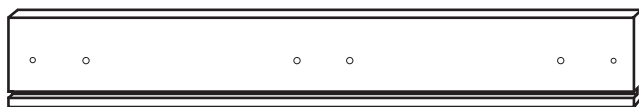

(1) Drawer Front-1480DOR
33 1/4" x 5 3/16" x 3/4"
(Inside View)

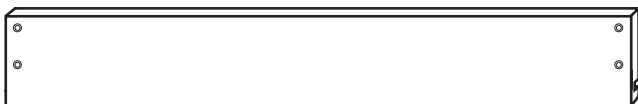

(1) Drawer Back-1480DOR
32 7/16" x 4 3/8" x 3/4"
(Outside View)

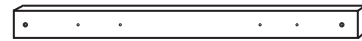

(4) Cutting Board Glide Support-1480DOR
19" x 3/4" x 3/4"
(Inside View)



(4) Cutting Board Side Rail-1480DOR
18" x 1 1/4" x 3/4"
(Inside View)



(2) Cutting Board Front-1480DOR
21 3/4" x 2" x 3/4"
(Inside View)

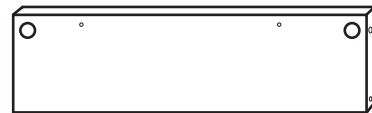

(2) Top Side Brace-1480DOR
22 1/4" x 5 1/8" x 3/4"
(Inside View)



(4) Mid/Bot Side Brace-1480DOR
22 1/4" x 2 1/4" x 3/4"
(Inside View)



(2) Drawer Glide Support-1480DOR
22 1/4" x 1 1/2" x 3/4"
(Outside View)

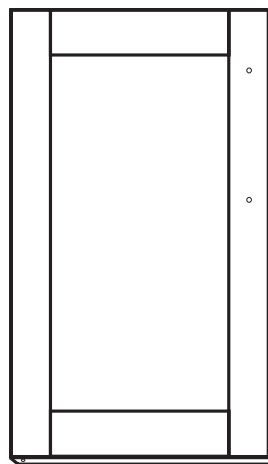

(2) Right Door -1480DOR
22 1/4" x 16 5/8" x 3/4"
(Inside View)

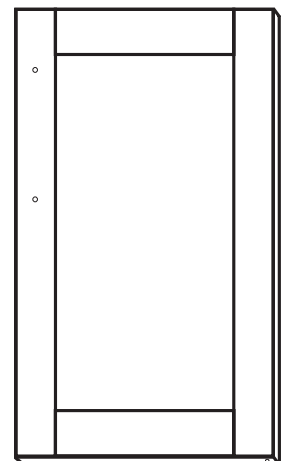

(2) Left Door-1480DOR
22 1/4" x 16 5/8" x 3/4"
(Inside View)

HARDWARE

Note: Not to scale



1 3/4" Phillips Flat Head Bolt (12)

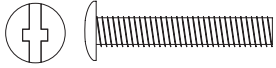

MSKRU M5-25 For Handles (16)



1 1/4" Phillips Flat Head #8 Screw (12)



1 3/4" Phillips Flat Head #8 Screw (12)



2 1/2" Phillips Flat Head #8 Screw (6)

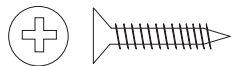

"L" Bracket Screws

5/8" Phillips Flat Head #6 Screw (8)

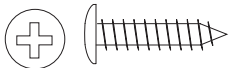

Glide Screws

7/16" Phillips Pan Head #6 Screw (24)



3/4" Long 3/16" DIA. Steel Pin (20)
(Brace Ends and Glide Supports)



1 1/2" Long 3/16" DIA. Steel Pin (18)
(Shelf Supports and Doors)

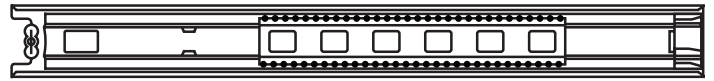

18" Full Ext Glide Sets (3)



10-24 Hex Nut (12)

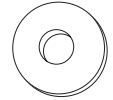

1/2" Flat Washer (16)

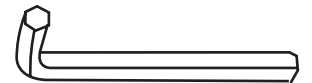

Allen Wrench



5/8" Wooden Disk (12)

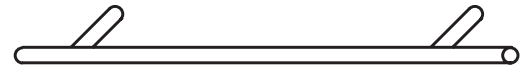

Bar Handle (8)



Bastion Post (10)



Bastion Set Screw (10)

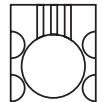

Bastion Barrel Nut (10)

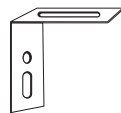

"L" Bracket (4)

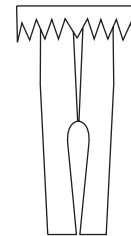

Caster Socket (4)

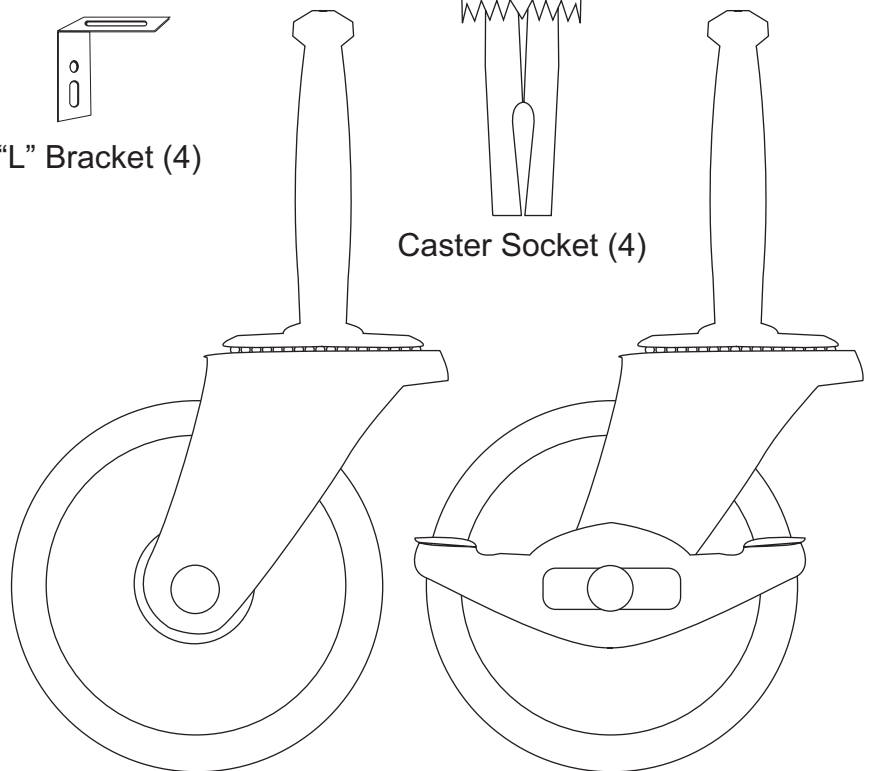

Caster (2)

Caster with Stops (2)

MAGNET PACK



Magnet (4)

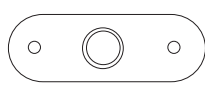

Magnet Plate (4)

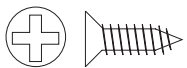

1/2" Phillips Flat Head #4 Screw (4)

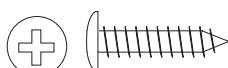

5/8" Pan Head Screw (8)

TIPS ON HOW THE BASTION FASTENING SYSTEM WORKS

1. The Bastion fastening system consists of a steel post (threaded on one end with a hole through the shaft on the other end); a Barrel Nut (cylindrical barrel-shaped with threaded open end & holes through the sides); and a Set Screw (Phillips slot on one end, pointed on the other)

2. To attach Posts: A) Dip threads of Post in vegetable oil. B) Align threaded end of Post with hole in wood, tap on slotted end with hard hammer until threads enter, then tighten down using a flat head screw driver or the provided allen wrench (See the Illus. Bas. 3 for alternate seating methods). **DO NOT TRY TO HAMMER THE POST ALL THE WAY IN AS IT WILL STRIP THE POST HOLE.** C) When solid shaft of Post hits wood, back out approximately 1 turn until the hole in the posts is properly aligned as per step by step directions. For example: the holes in the posts on the inside of the drawer front will be parallel with the long length of the drawer front when properly seated.

3. A) Place a Barrel Nut into the nut access hole, so that the threads in the nut face out. The small notches on either side of the nut opening, indicate the location of the holes through the sides of the nut. B) Insert the posts through the end of the braces (or drawer sides); through the holes in the sides of the nut. When properly aligned, you will see the hole in the post inside the barrel nut. Post hole should be slightly off-center toward the wood.

4. Insert the Set Screw into the threaded end of the nut and tighten down. The tip of the Set Screw will seek the center of the hole in the Post as it is tightened down, forcing the Nut toward the main shaft of the Post. This is what tightens the wooden parts together. Set screws should thread easily – **DON'T CROSS THREAD!** If Set Screw doesn't thread easily, check position of the hole in Post.

5. If the wooden parts are not tight against each other, the Post needs to be screwed a half turn at a time until wood joints are tight.

Illustration Bas. 1

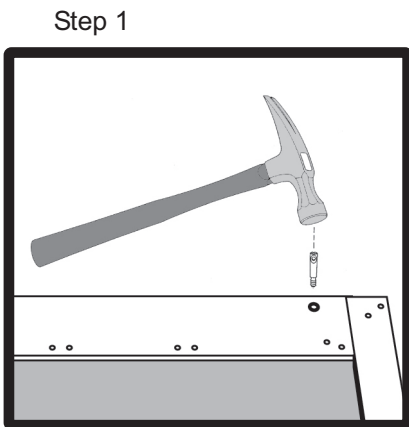
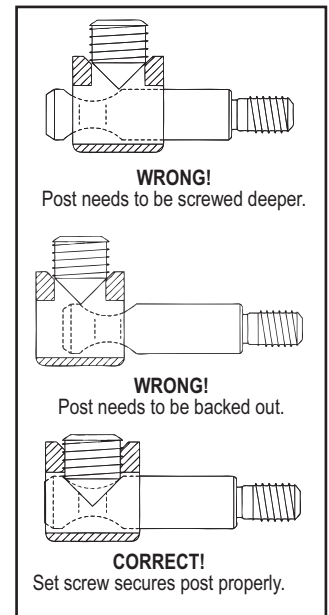
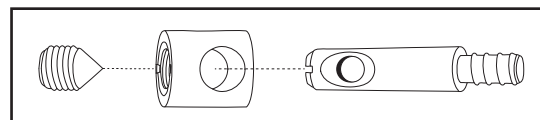
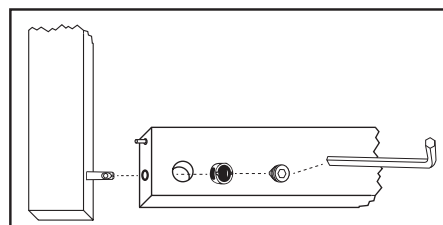

Illustration Bas. 2



Step 2



Allen Wrench Provided

Illustration Bas. 3

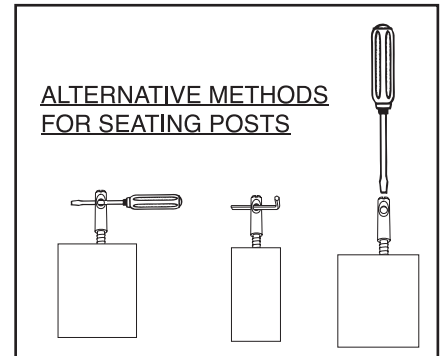

See video on our website!

If you have any questions regarding assembly or missing or damaged parts, call our customer support number:

607-652-7321 or 888-732-7321.

Customer Support Hours are 8am-5pm Mon. - Fri. Eastern Time zone.

STEP 1

Slide Out Cutting Board Assembly - Part 1

2 Pull Out Cutting Board Tops, 2 Cutting Board Fronts, 4 Cutting Board Sides.

Lay Pull Out Cutting Board Top on its back so holes face up. Then attach the Cutting Board Front to the Top, so that the counter sunk holes face up, using 2 1/2" #8 screws (the curved edge should face outward). Now attach the Cutting Board Side Rails to the Top so that the glide holes face out and the counter sunk holes face up, using 1 3/4" #8 screws.

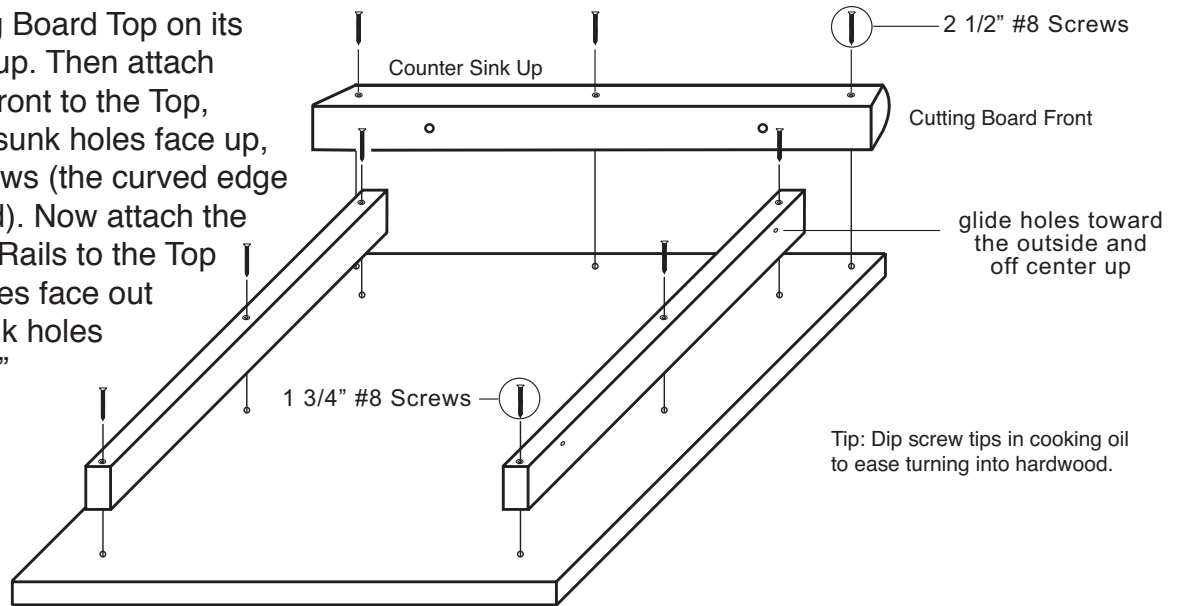

STEP 2

Slide Out Cutting Board Assembly - Part 2

A. Take all of the glides and detach the inserts by fully extending the glides and pressing down on the black tab and pulling them out.

B. Attach Glide Inserts to the sides of the Slide Out Cutting Boards using Two (2) 7/16" #6 Pan Head Screws.

C. Attach Handles to the Cutting Board Top using M5-25 machine screws. Glides should be almost 1/8" to the front edge of the Sides.

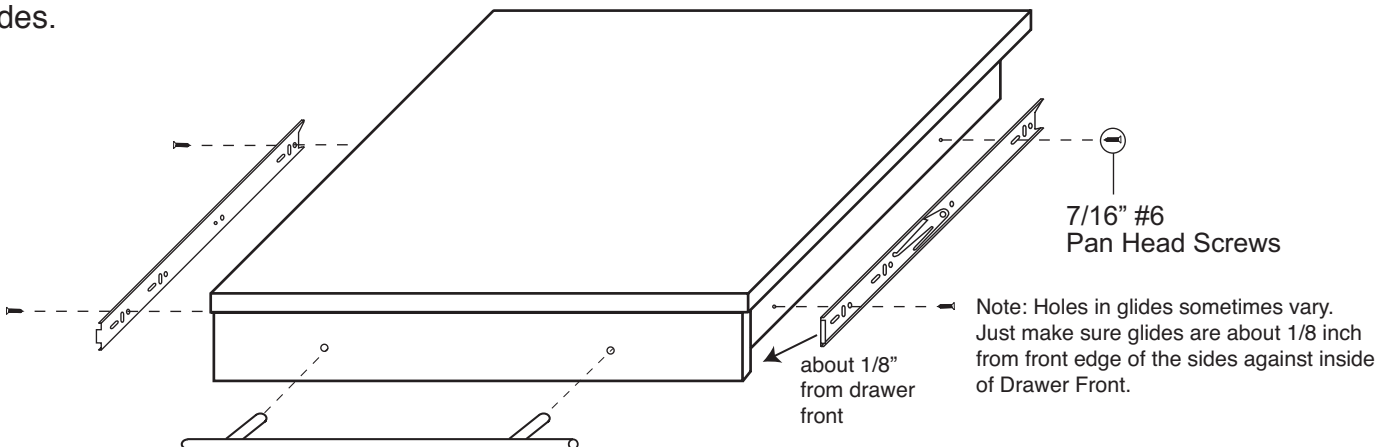
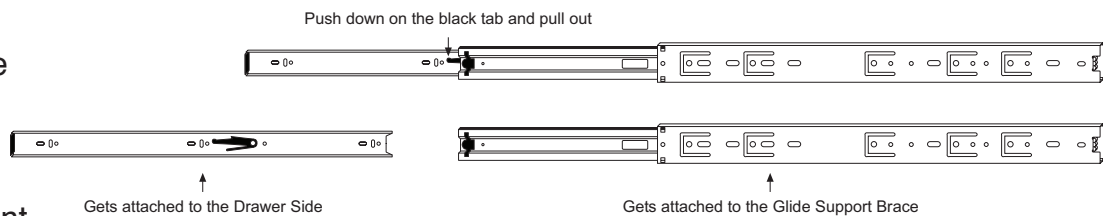

STEP 3

Drawer Assembly

2 Drawer Sides, 1 Drawer Back, 1 Drawer Front, 1 Drawer Bottom

Attach Drawer Back to Drawer Sides using 1 1/4" #8 screws, then insert Drawer Bottom into slots best side up. Put Bastion Posts into Drawer Front & secure to Drawer Sides using Barrel Nuts & Set Screws. Attach Handles using Pan Head M5-25 Machine Screws. Screw the Glide Inserts to the Drawer Sides using 7/16" Phillips Pan Head #6 Screws. Glide inserts will be almost flush with the inside of the Drawer Front when mounted.

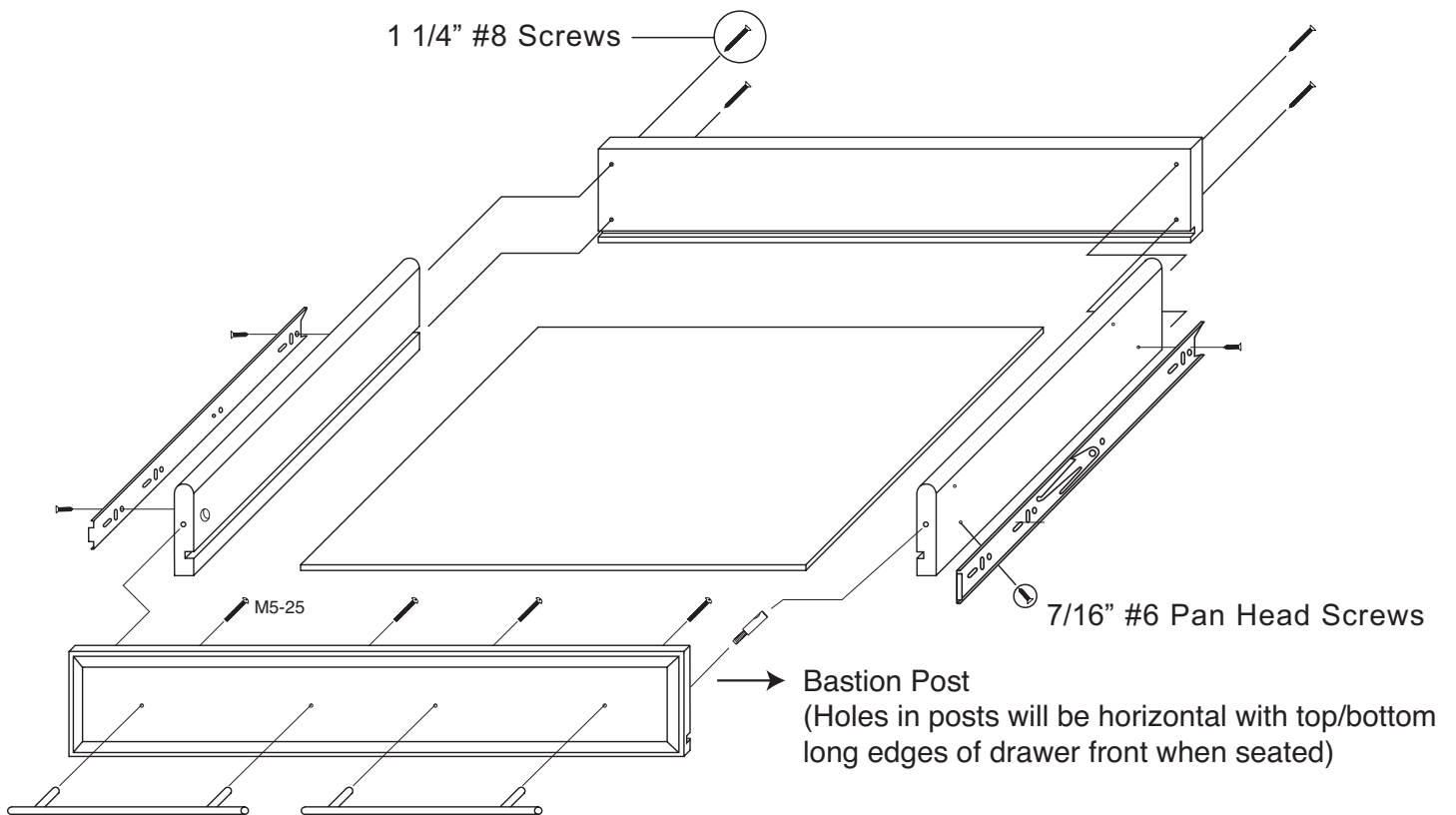

STEP 4

Brace Preparation

Insert 3/4" Pins into each end of the Top and Bottom Braces and Drawer Glide Supports.
OK if Pins are loose.

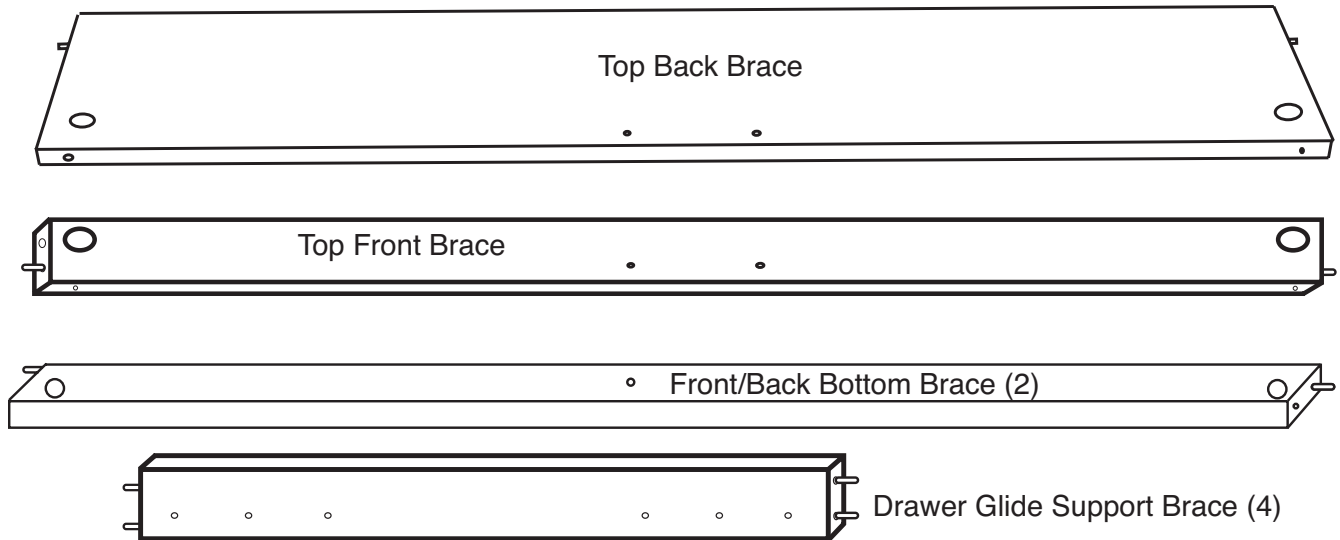

STEP 5

Leg Preparation

Insert Bastion Posts into the 2 sets of Legs as illustrated.

Tighten the Bastion down all the way, then back it out about 1 turn so that the hole in the Bastion Post is perpendicular to the long edge of the Leg. See illustration or video on Bastion System at www.catskillcraftsmen.com.

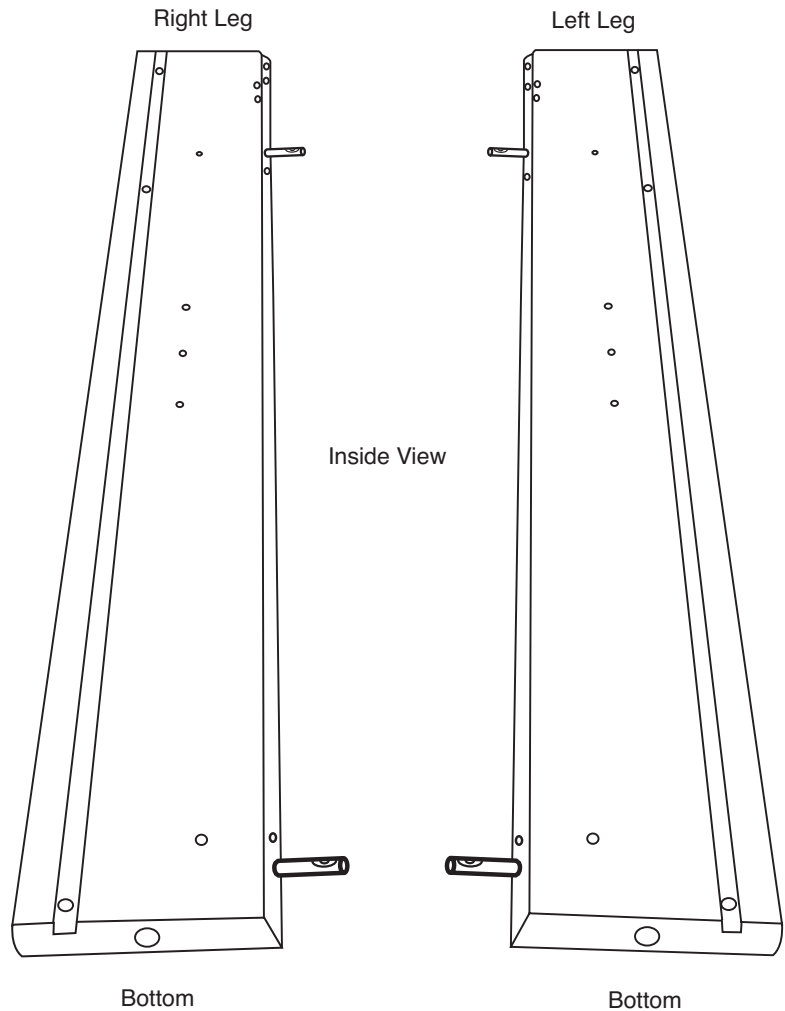

STEP 6

Front and Back Panel Assembly

A. The Back Panel Assembly consists of a Right and Left Rear Legs, Top Back Brace, Bottom Brace, a Left Door and a Right Door. Insert 1 1/2 inch Pins into the top and bottom of the Right and Left Doors. Be sure to add a Washer over the Pins on the bottom of the doors. Insert the Bottom Door Pins into the holes in the bottom brace as illustrated. Insert the Pins in the top of the doors into the Top Back Brace as illustrated.

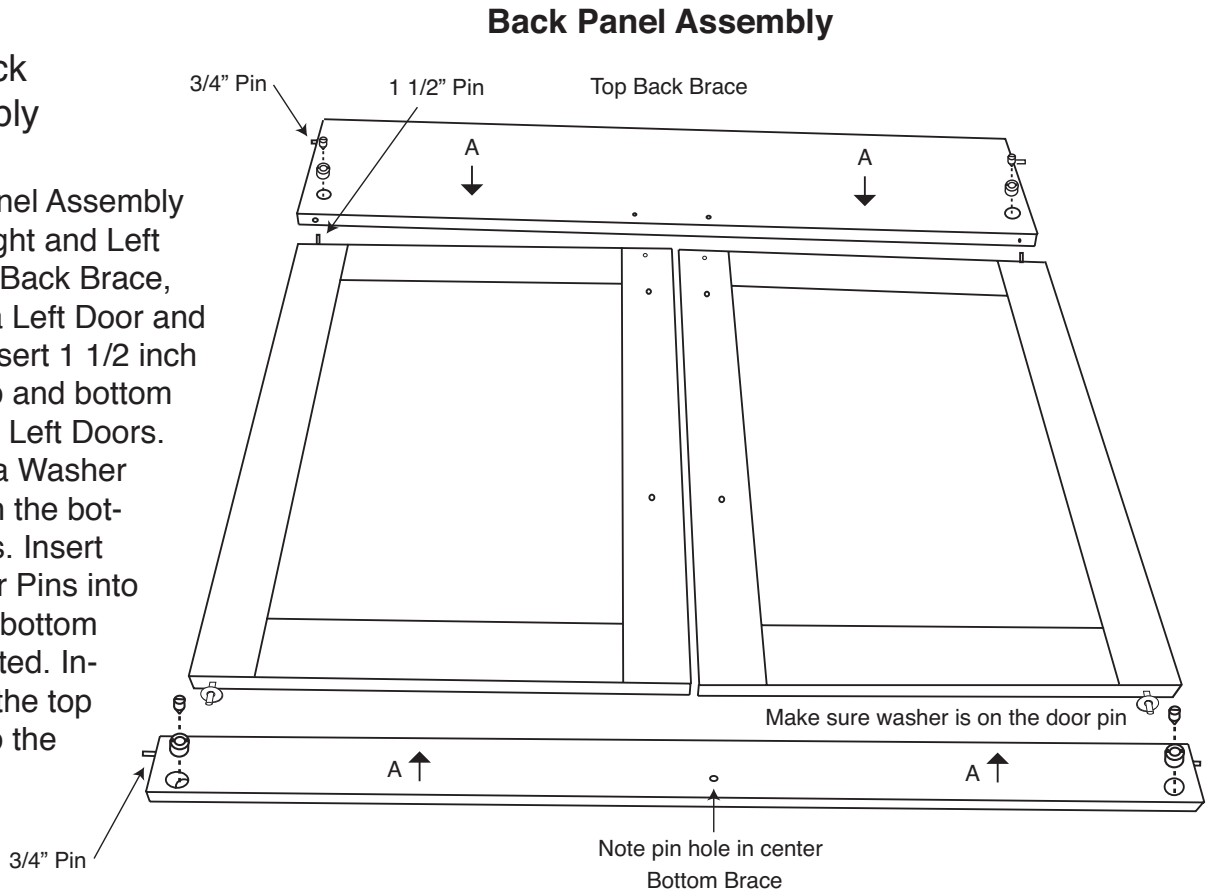

B. Fasten the Legs to the one side top/bottom, then the other side using the Bastion Posts and Pins already inserted in steps 4 and 5. Insert Barrel Nuts into the Nut Access Holes and tighten down with Set Screws.

C. Repeat the entire process for the Front Panel Assembly.

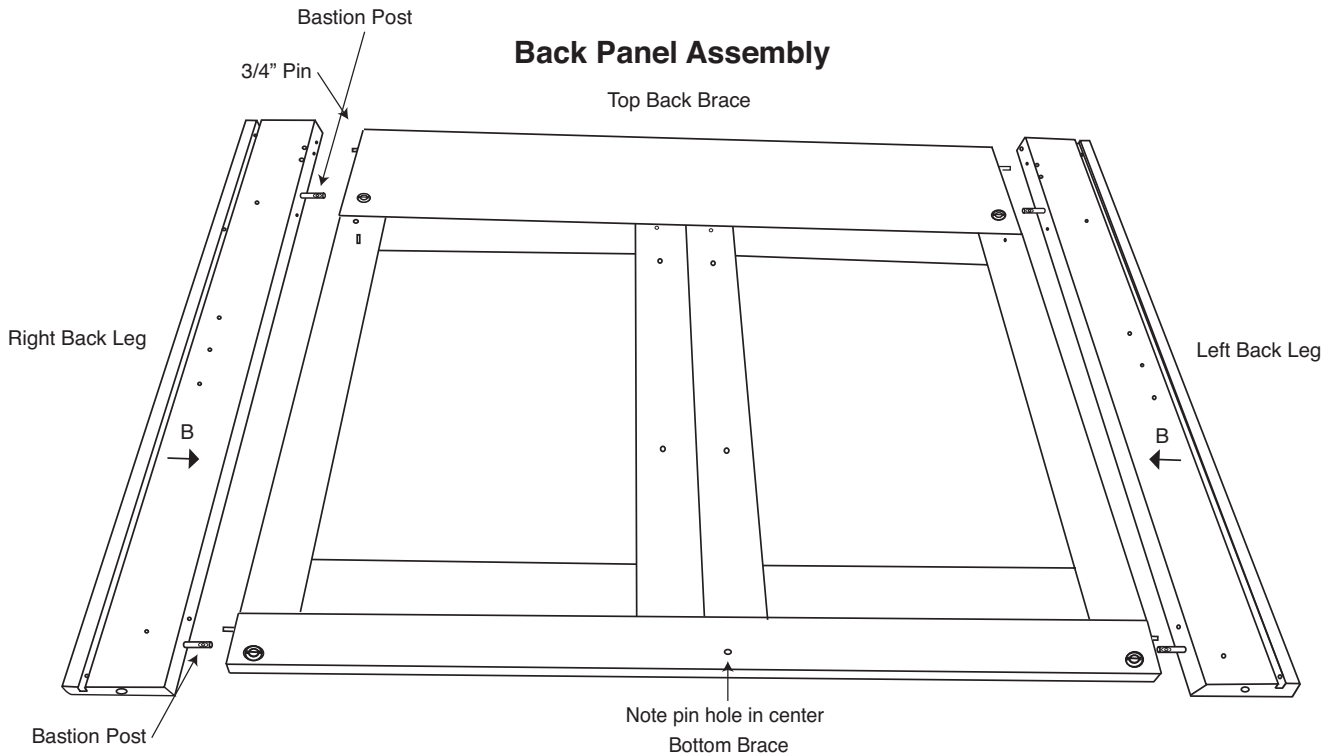

STEP 7

Attach Magnet Plates

Using 1/2" Phillips Flat Head #4 screws from your Magnet Pack attach the Magnet Plates to the small pilot holes at the top of the Doors. Bumps on Plate go against wood.

Back Panel Assembly

1/2" Phillips Flat Head #4 Screw

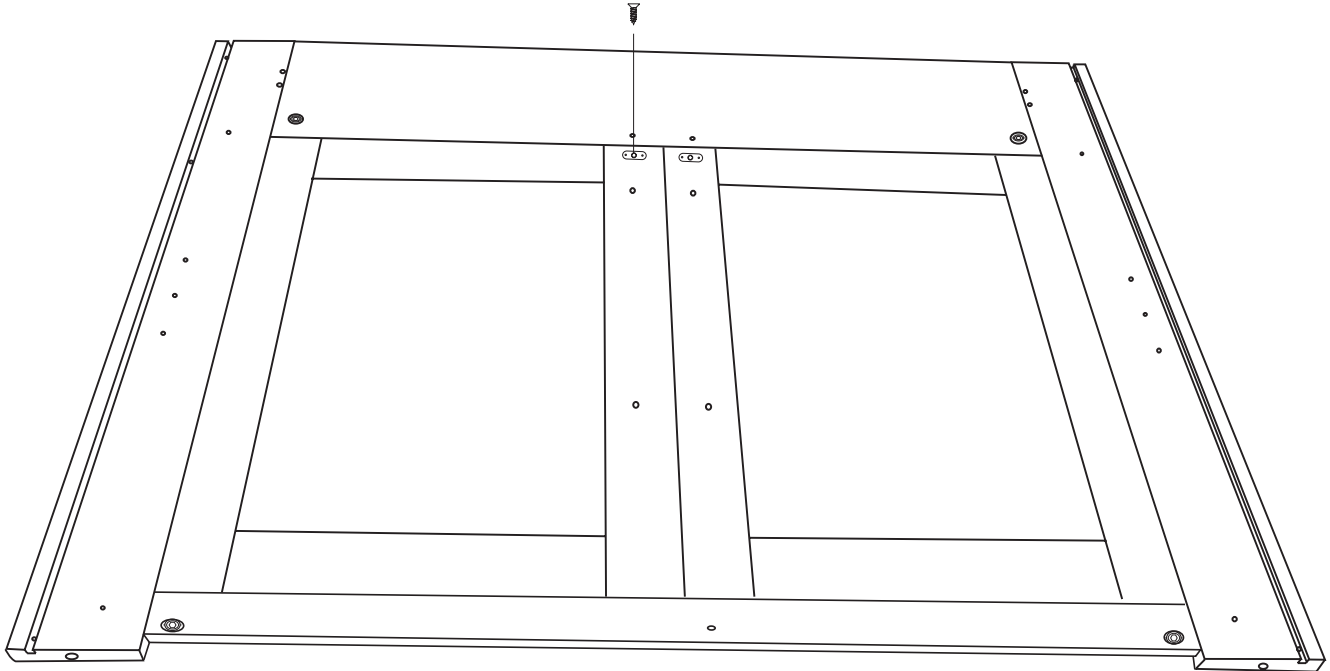

Front Panel Assembly

1/2" Phillips Flat Head #4 Screw

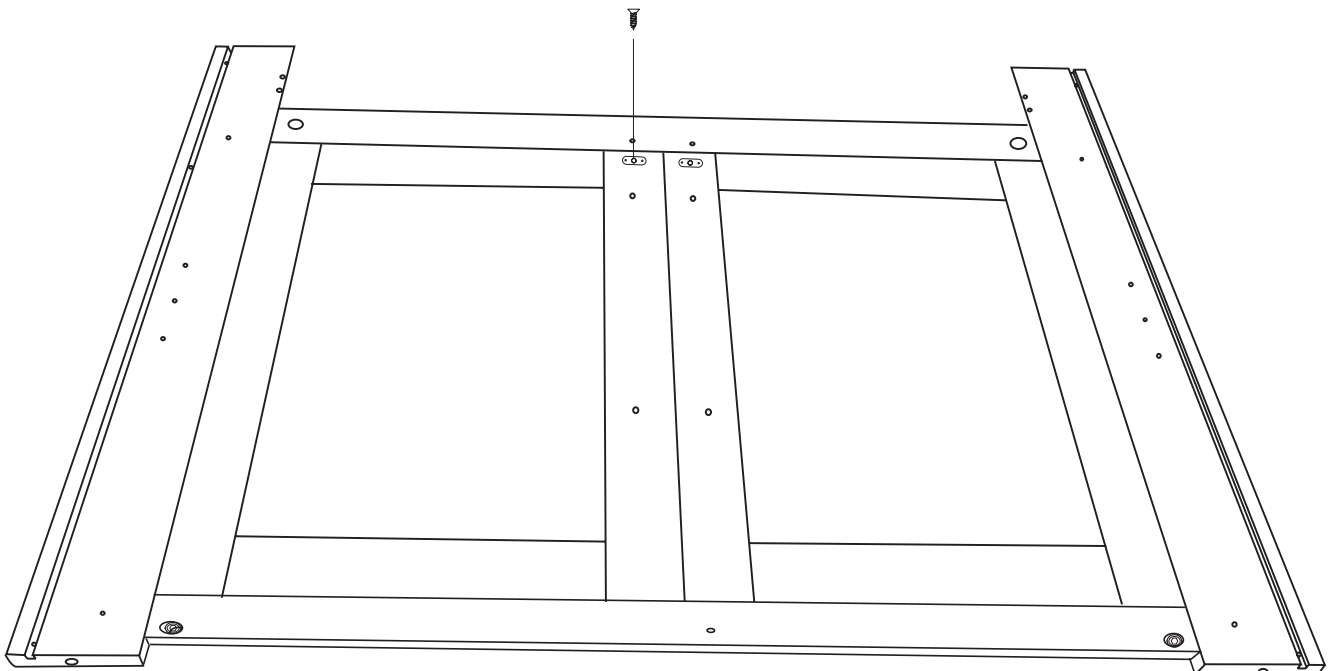

STEP 8

Insert Caster Sleeves and Cutting Board Glides

A. Insert the Caster Sleeves into the holes in the bottom of the Legs and tap in with a hammer until the teeth grabs the wood - don't pound flat! Repeat for the front assembly.

B. Attach the Magnets to the bottom inside edge of the Glide Supports using the round head screws included in the Magnet Pack.

C. Attach the Glide Supports to the Top Back Brace using 1 1/4" #8 screws. Be sure to insert 3 Washers between the Glide Support and the Top Back Brace as illustrated below.

D. Attach the Cutting Board Glides using 7/16" #6 Pan Head Screws to the Cutting Board Glide Support so that they extend to the outside of the cart. The front edge of the Glide is almost flush with the front edge of the Glide Support as in the illustration. Two holes in the Glide Support are not used.

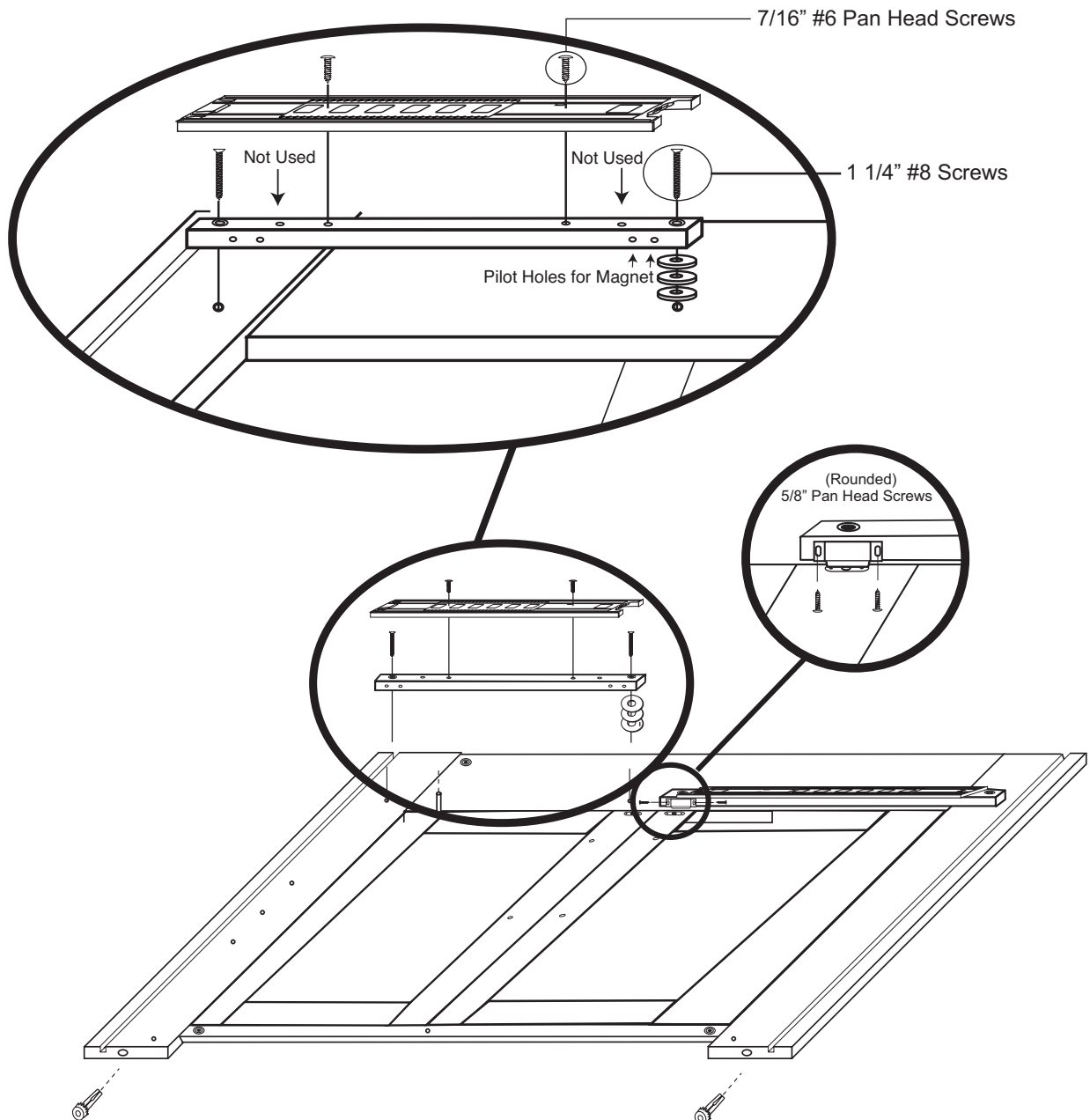

STEP 9

Brace Prep

A. Attach the Drawer Glides to the Glide Support Sticks using two 7/16" #6 screws. Slide top part of glide to expose pilot holes in glide support sticks.

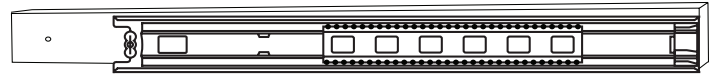

Illustration 9A

The front edge of the glide will overhang the front edge of the Glide Support Stick by 1/8 inch. See Illustration 9A.

The Glide Sticks have 6 holes - only 2 are used. The pilot holes should be facing down and the glide is slightly below the long edge of the stick when positioned properly.

B. Attach Bottom Side Braces (illustration 9B), Middle Side Braces, (illustration 9C) Top Side Braces and drawer glide support sticks (illustration 9D) to the back assembly using 1 3/4 machine screws and nuts. Position braces as illustrated.

Note: This step requires access to both sides of the back panel in order to insert the machine screws (bolts) from the front & attach the nuts/braces on the inside with help. The easiest way is to invert the top on a table so that one side overhangs the table top giving you access from the bottom to the holes in one of the legs. This allows you to insert the bolts through the holes in the front of the leg, through the leg, into the ends of the bottom, middle and top braces. Secure with a nut. Repeat with the other side. If you don't have a suitable table, you can place the unit on the floor and prop up one side about 6" to allow you access to the bolt holes. With a friend, you can stand the back panel upright and work from that position. The doors could swing free at this point so be careful not to mash your fingers.

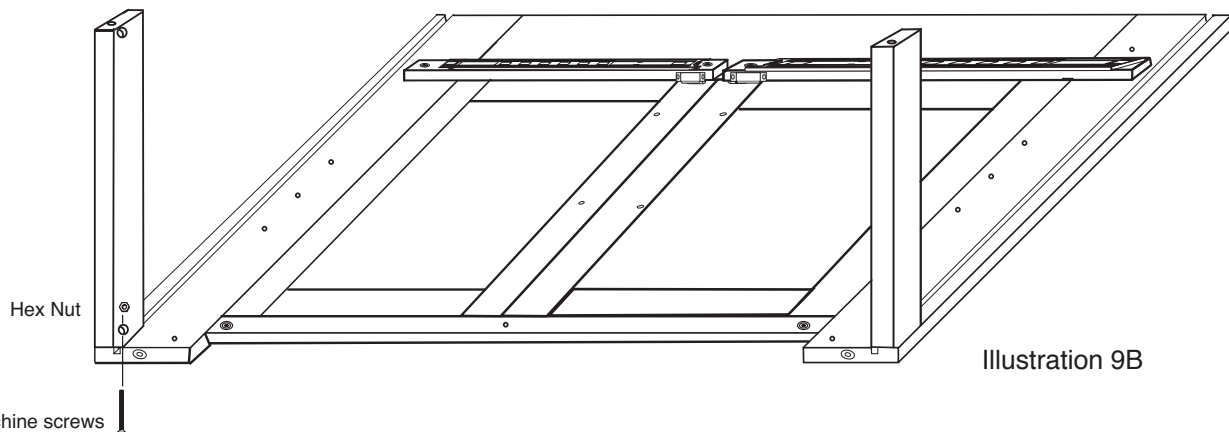

Illustration 9B

Note: See our assembly video at www.catskillcraftsmen.com for tips on assembling this cart alone.

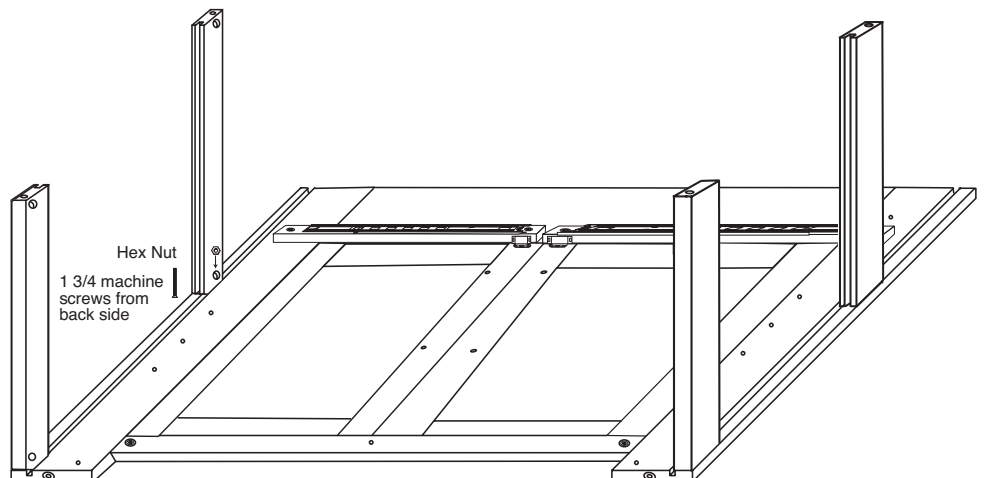

Illustration 9C

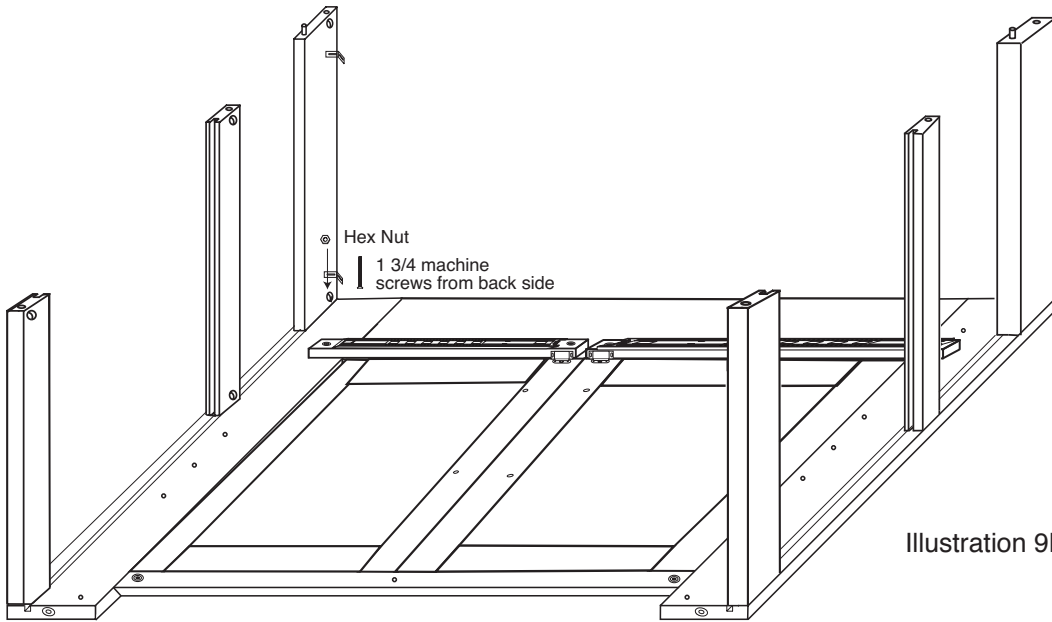

Illustration 9D

TIP: Place a towel or tablecloth (movable) on the table, that will allow you to rotate the Back Assembly without scratching the tabletop.

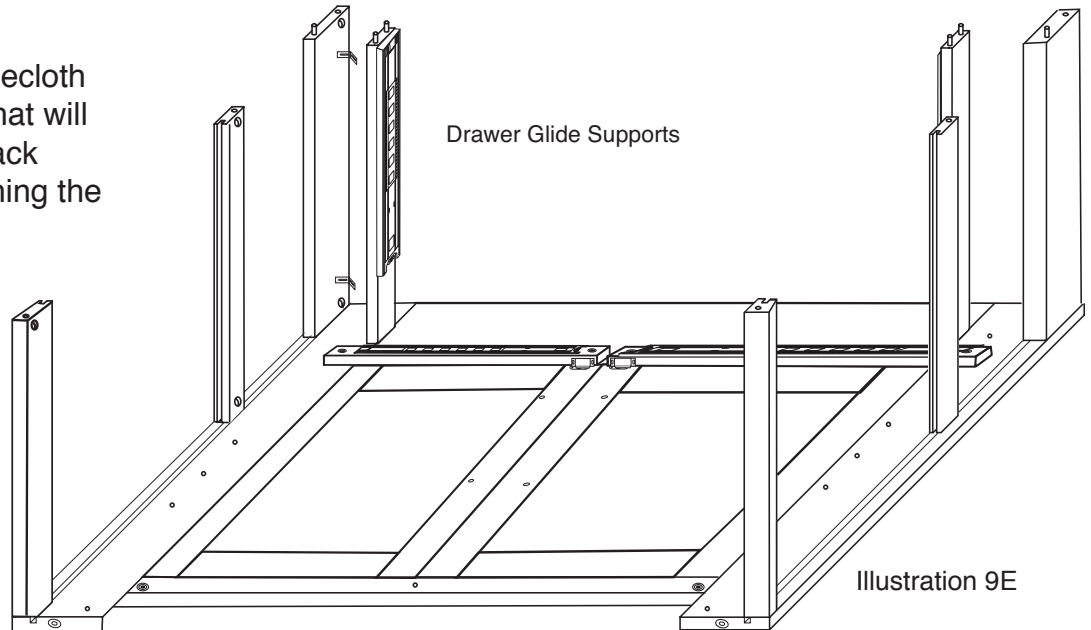

Illustration 9E

C. Insert the Side Panels into the slots of the Bottom/Middle Side Braces. Best side out! (Illustration 9F)

E. Attach the Drawer Glide Supports. Start by aligning the 2 Pins in each end of the Sticks into the pin holes in the leg. Make sure Glide is positioned as illustrated in 9E and 9F.

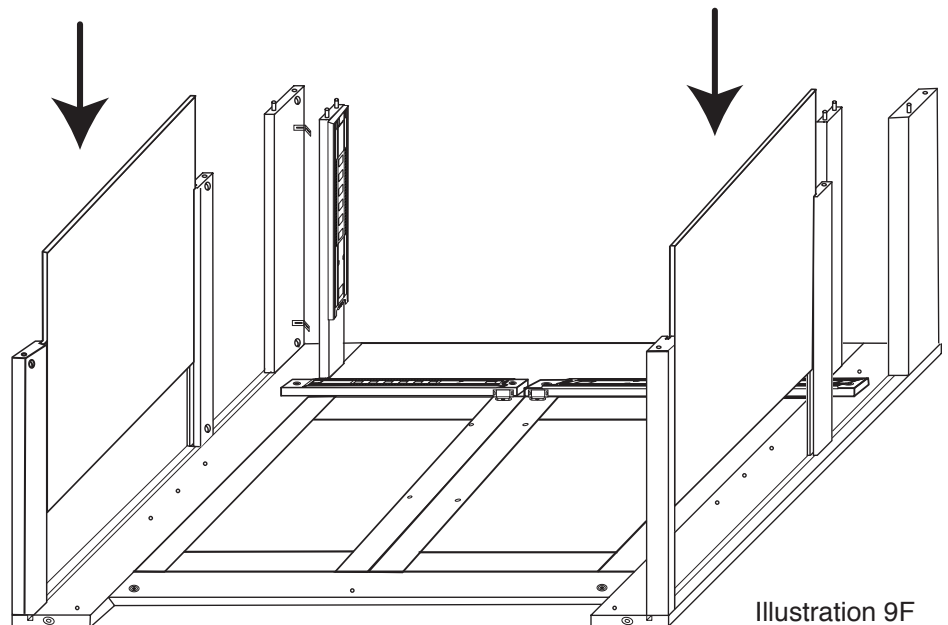

Illustration 9F

STEP 10

Attach Front Assembly

2 Person Job!!

A. Attach the front assembly to the sides using Pins and 1 3/4" Machine Screws/Nuts.

B. Insert the castors into the caster sockets.

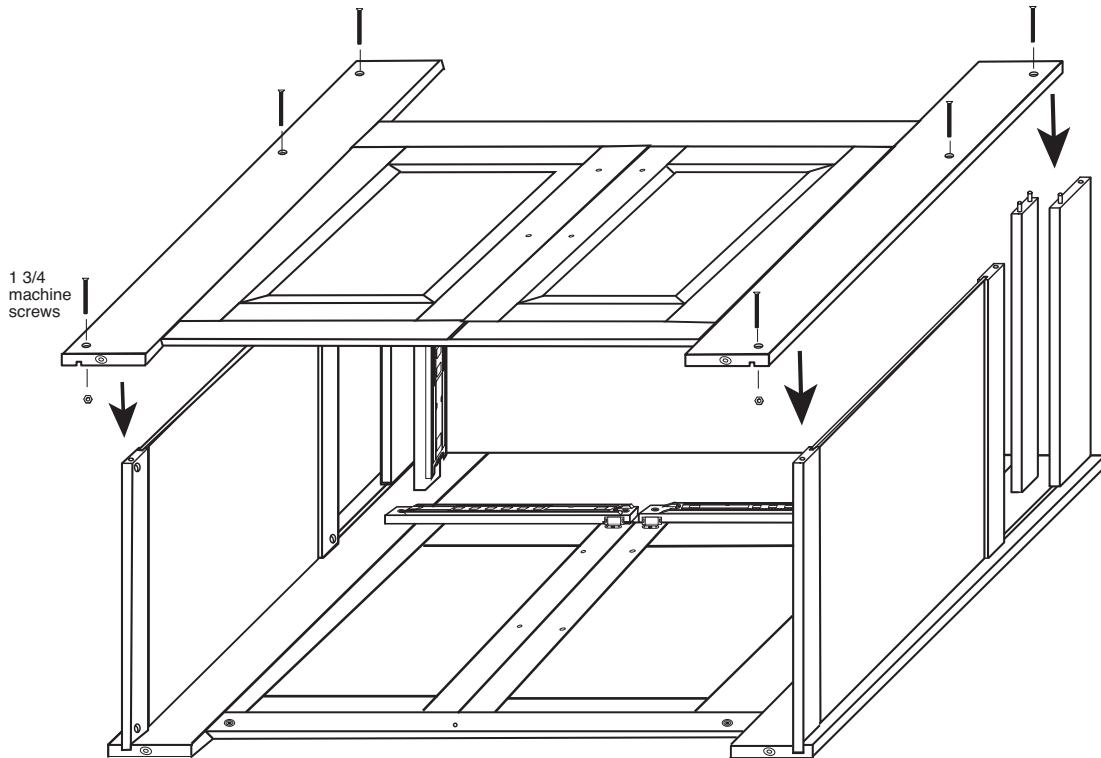

Illustration 10A

Tip: Don't try to align all the pins at the same time. Better to work from one end toward the other. i.e. insert Pins on right sides lowering Front Assembly and align Pins on left side until all Pins are seated.

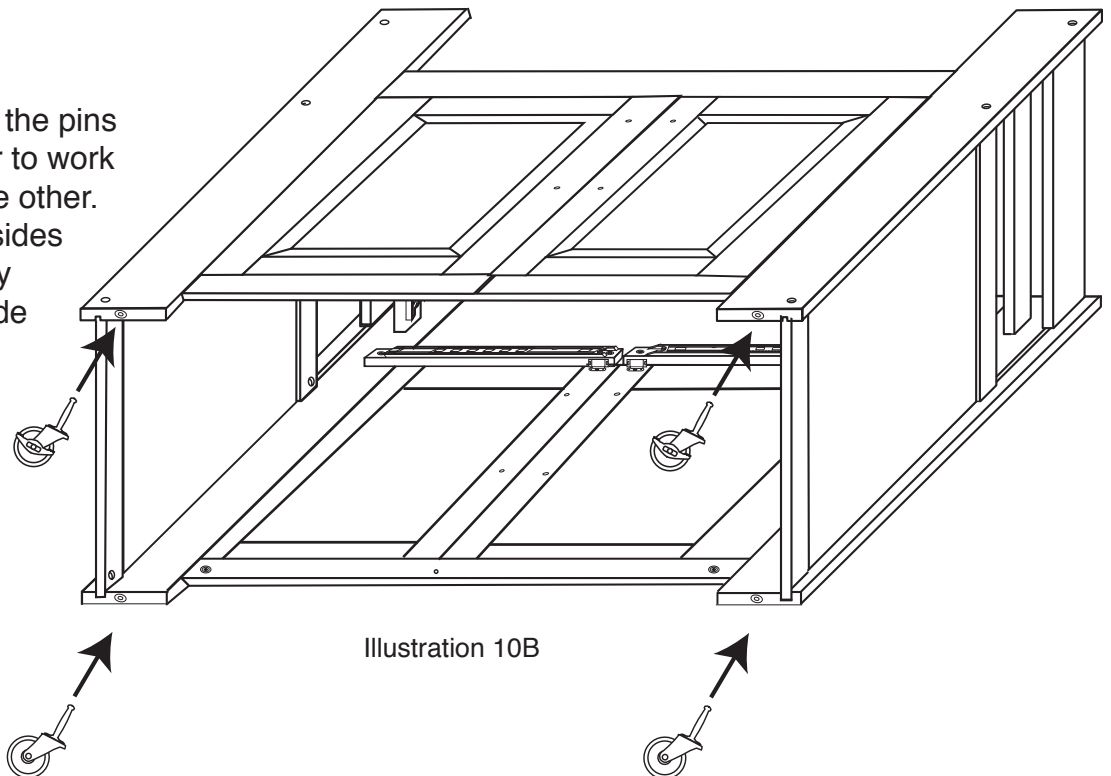

Illustration 10B

STEP 11

Castors and Shelf Pins

A. Upright the unit.

B. Insert (6) 1 1/2" pins into the pin holes at the bottom (1 in each leg and 1 in each bottom brace). The Middle Shelf has 3 adjustable heights, determine which height to use and insert the 1 1/2" pins into the appropriate holes in the legs, as the Middle Shelf is adjustable.

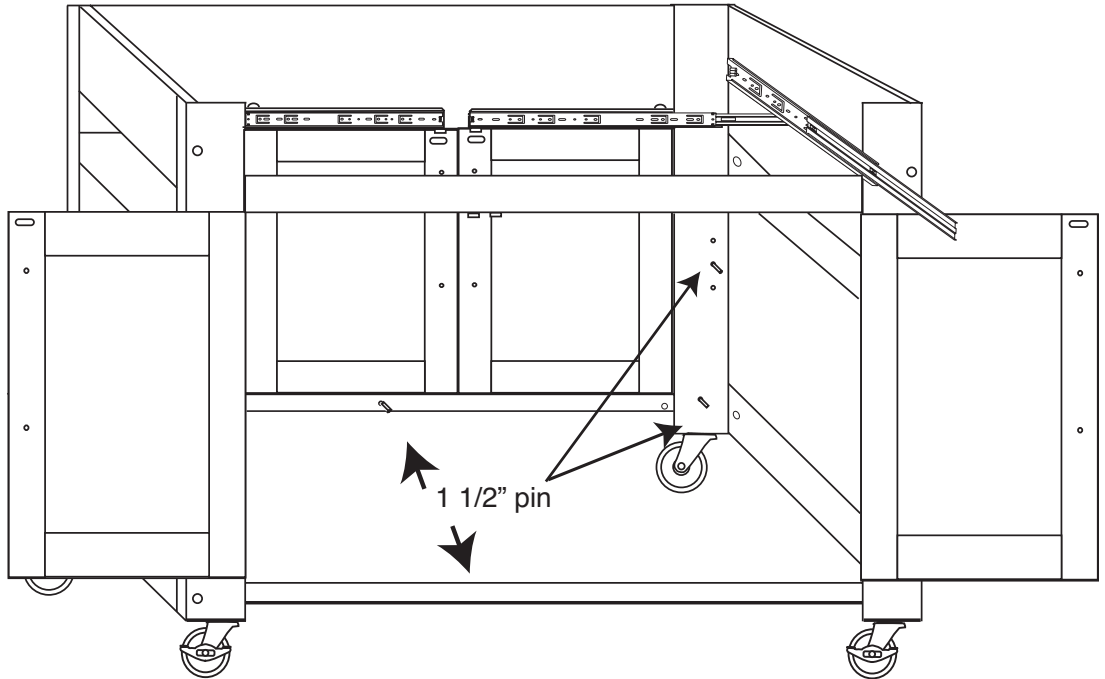

STEP 12

Tabletop

Lay Top upside-down on flat smooth surface and screw on the "L" brackets using 5/8" #6 flat head screws as in illustration. Attach the "L" bracket to the top using the hole, not the slot on the "L" bracket. Then flip assembled unit upright and attach the Top to the assembled unit using 5/8" #6 flat head screw through the "L" brackets into the pilot holes in the top side brace

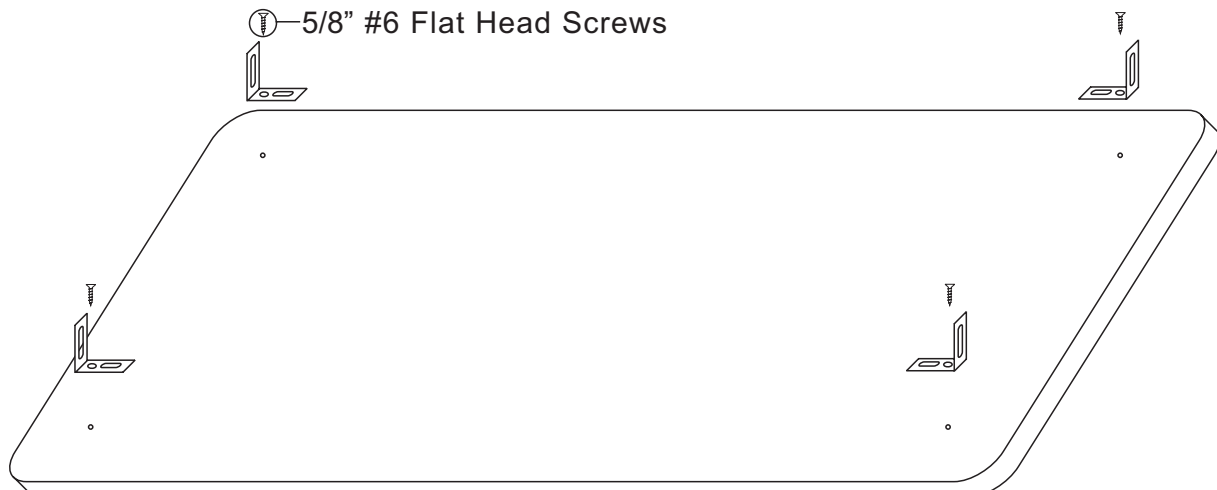

STEP 13

Insert Shelves

Slide in the Bottom Shelf and fit it over the Bottom Pins. Then slide in the Middle Shelf (with edge banding) and fit it over the middle set of Pins.

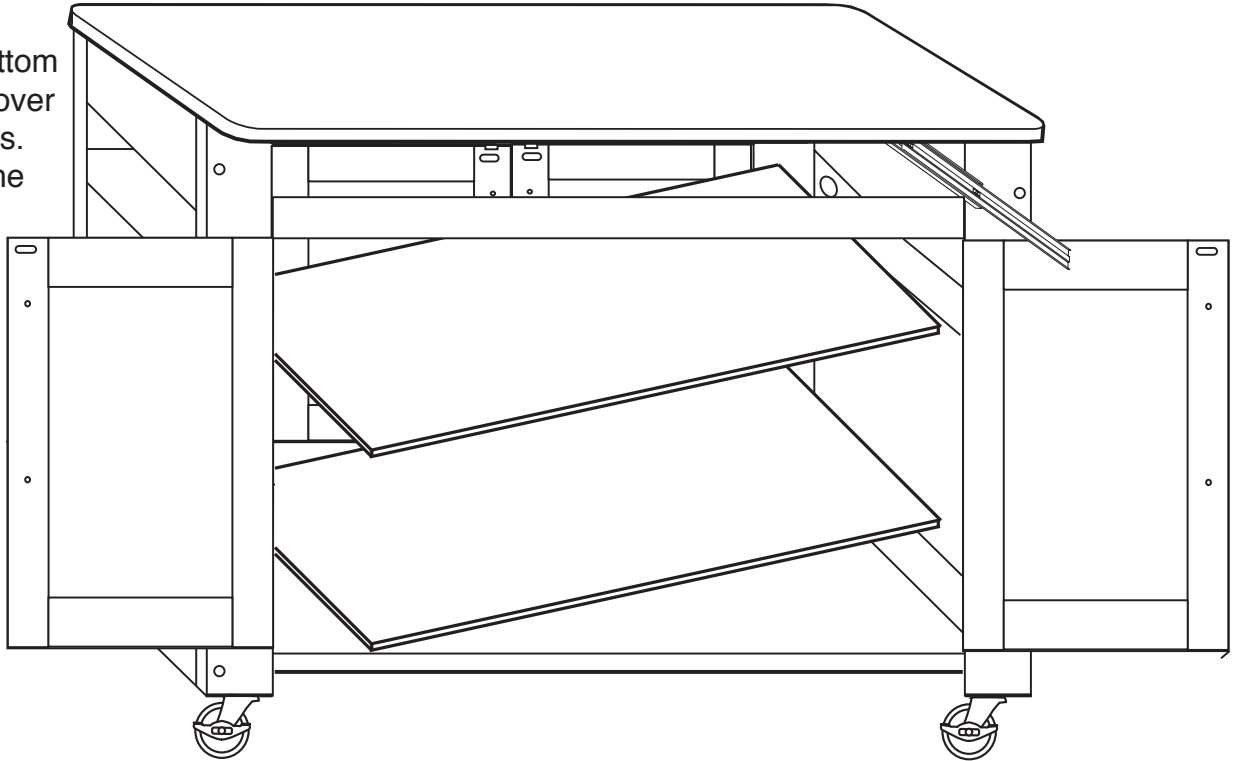

STEP 14

Add Drawer and Cutting Boards

Slide the Drawer into the front of the cart then slide the Slide Out Cutting Boards into the sides of the cart. Drawer will push in halfway and seem to stop.

It is O.K. to apply greater pressure to align ball bearings properly then glides will work smoothly.

Then tap in the 5/8 Wooden Plugs into the holes in the Legs.

Tip: Give Drawer/Boards a hard shove inward to seat.

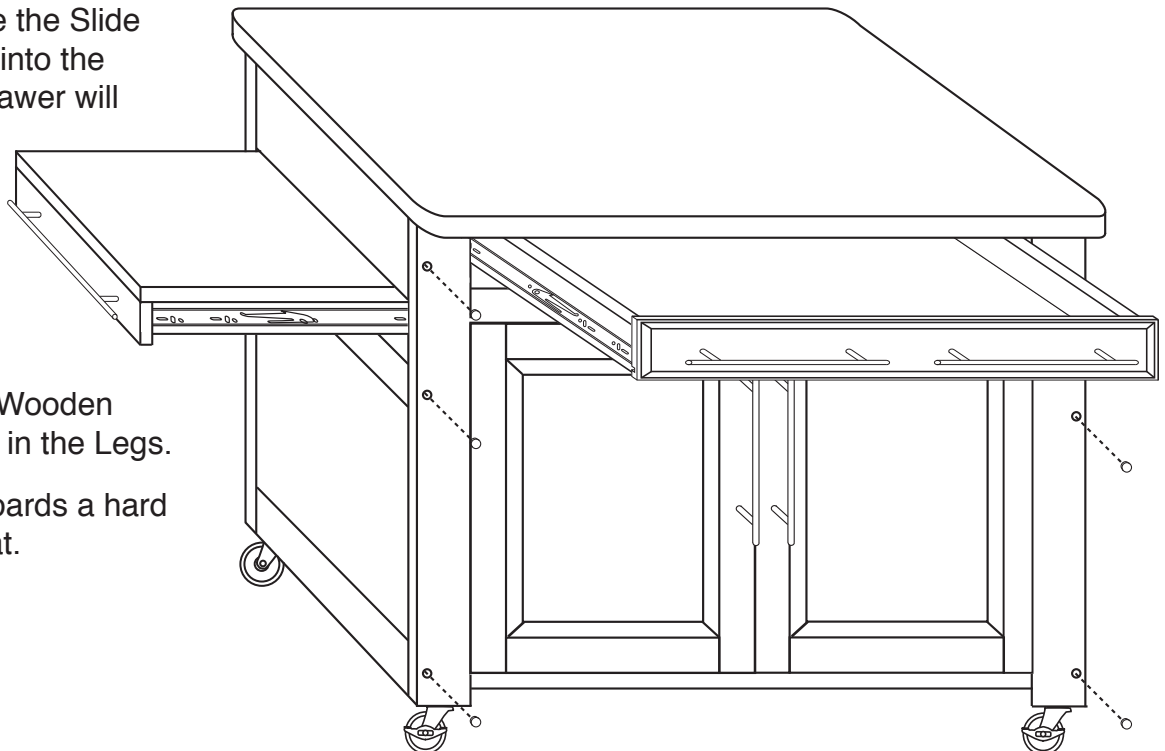



For continued beauty and long life of your Catskill Craftsmen cart, we recommend Catskill Craftsmen's Butcher Block Oil.

Our Butcher Block Oil is available directly from Catskill Craftsmen's factory. For one eight ounce (8 fl. oz.) bottle, which is sufficient for two applications, simply send \$6.95 along with the completed coupon to the address below. Visit us online at www.catskillcraftsmen.com to browse our assortment of butcher block care products. Visa and Mastercard are accepted online .



Catskill Craftsmen, Inc.
15 West End Ave.
Stamford, NY 12167-1296



BUTCHER BLOCK OIL COUPON

Please send me _____ # of bottle(s) of the Catskill Craftsmen Butcher Block Oil at \$6.95 per bottle. My check or money order is enclosed for a total of \$_____.

Item code: 1480DOR

Name _____

Address _____

City _____

State _____ Zip _____

Please make checks payable to Catskill Craftsmen Inc. 15 West End Ave., Stamford, NY 12167-1296