

**PLEASE READ AND FOLLOW ALL WARNINGS**



**Air Nibbler**

**Read Operating Instructions**

Always become familiar with all the instructions and warnings before operating any power tool.



**Always Wear Approved Eye Protection**

Impact resistant eye protection should meet or exceed the standards as set forth in the United States ANSI Z87.1, Occupational and Educational Eye and Face Protection. Look for the marking Z87.1 on your eye protection to insure that it is an approved style. For further information, ANSI Z87.1, Occupational and Educational Eye and Face Protection, is available from the American National Standards Institute, Inc., 11 West 42nd Street, New York, NY 10036.



**Hearing Protection is Recommended**

Hearing protection should be used when the noise level exposure equals or exceeds an 8 hour time-weighted average sound level of 85 dBA. Process noise, reflective surfaces, other tools being operated nearby, all add to the noise level present in your work area. If you are unable to determine your noise level exposure, we recommend the use of hearing protection.



**Avoid Prolonged Exposure to Vibration**

Tools can vibrate during use. Prolonged exposure to vibration or very repetitive hand and arm movements, can cause injury. Stop using any tool if discomfort, tingling feeling or pain occurs. You should consult your physician before resuming use of the tool.



**90 PSIG Maximum**

This tool is designed to operate at

an air pressure of 90 pounds per square inch gauge pressure (90 PSIG) maximum, at the tool. Use of higher air pressure can, and may cause injury. Also, the use of higher air pressure places the internal components under loads and stresses they were not designed for, causing premature failure. The air supply should be clean and dry, preferably lubricated. For best results, drain the moisture from your compressor daily.

**WARNING:**

Some dust created by power sanding, sawing, grinding, drilling, and other construction activities contains chemicals known to cause cancer, birth defects or reproductive harm. Some examples of these chemicals are:

- Lead from lead-based paints
- Crystalline silica from bricks, cement and other masonry products
- Arsenic and chromium from chemically treated lumber

Your risk from these exposures varies, depending on how often you do this type of work. To reduce your exposure to these chemicals, work in a well-ventilated area and work with approved safety equipment such as those dust masks that are specially designed to filter out microscopic particles.

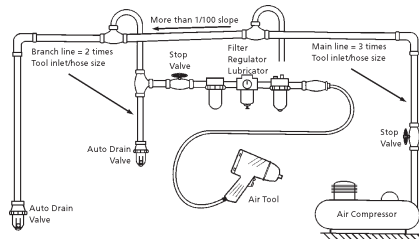

**Description**

Florida Pneumatic air nibbler weights two pounds but can cuts through mild steel without deforming or burring metal. Cuts around templates with ease.



devices as furnished by the manufacturer. Where an air tool is modified or altered, the modifier shall provide the safeguards to enable it to be safely used in the operations intended and to comply with any applicable provisions as contained in ANSI B186.1.

**Safety Instructions**

The following instructions are furnished as general guidelines for use of your pneumatic tool. They cannot comprehensively cover all possible or conceivable uses of the subject tool. For additional information on the safe use of air tools, we advise you to obtain a copy of ANSI B186.1 Safety Code for Portable Air Tools, available from the following source:

American National Standards Institute, Inc.  
11 West 42nd Street  
New York, NY 10036.

The use of the word "shall" in the following instructions, indicates that adherence to the particular requirement is necessary to conform to ANSI B186.1.

**Tool Application and Usage**

Portable tools shall be used only for the purposes intended in their design and within the capacity for which they were intended and rated. It shall be the tool owner's and/or employer's responsibility to instruct each operator in the safe use of the tool. Tools shall not be used without guards and safety

**Tool Installation**

Pressure regulators shall be used to limit air pressure to the rated pressure where the supply pressure exceeds the tool's rated pressure. Air hoses and lines shall be relieved of compressed air before being disconnected or disjoined, unless there is automatic valve closing protection at the joint being separated. Synthetic lubricants which can cause deterioration of elastomer seals shall not be used in air systems of air tools.

**Tool Maintenance**

It shall be the tool owner's and/or employer's responsibility to assure that tools are maintained in a safe operating condition. Tool maintenance and repair shall be performed by authorized, trained, competent personnel. Tools shall be disconnected from their compressed air supply before repairs are attempted. Repairs shall be consistent with the manufacturer's recommended procedures. Tool, hoses and fittings shall be replaced if unsuitable for safe operation. It shall be the tool owner's and/or employer's responsibility to keep required rating markings and warnings on the tool in legible condition.

*Read these instructions carefully before attempting to install, operate or service this Florida Pneumatic product. Failure to comply with the instructions could result in personal injury and/or property damage! Retain these instructions for future reference.*

Florida Pneumatic Manufacturing Corporation  
851 Jupiter Park Lane, Jupiter, Florida 33458  
Toll Free 1-800-327-9403



Strokes per min.....	2,600
Maximum capacity.....	16-gauge steel
Width of cut.....	3/16" (4.5mm)
Minimum cutting radius.....	1 3/8" Dia.
Weight.....	2 1/4 lbs.
Length.....	7"
Average air consumption.....	4 CFM
Recommended hose size.....	3/8" I.D.
Air inlet.....	1/4"NPT
Maximum operating pressure.....	90 PSI

**Parts Breakdown for FP-711A**

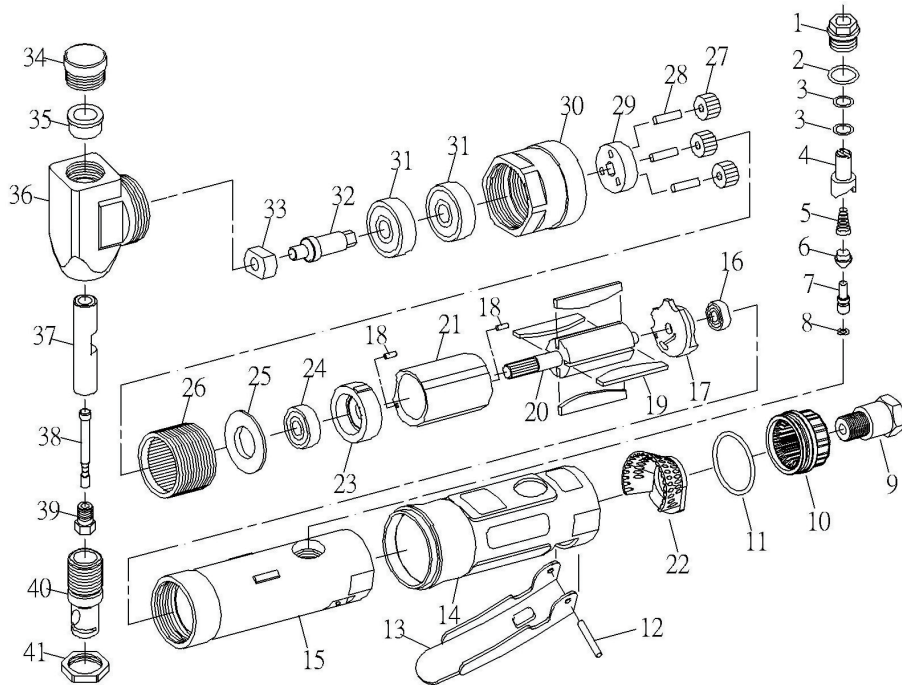

**Replacement Parts for FP-711A**

NO	PART NO	PART NO	Q'TY	NO	PART NO	PART NO	Q'TY
1	9ST70001	SCREW	1	22	970022A	CONE MUFFLER	1
2	9ST70002	O-RING (P12)	1	23	9ST70023	FRONT PLATE	1
3	9ST70003	O-RING (P8)	2	24	970024A	BEARING (608ZZ)	1
4	9ST70004	AIR REGULATOR	1	25	935025	WASHER	1
5	950332	SPRING	1	26	935026	THREAD RING GEAR(42T)	1
6	970429	VALVE STEM BUSHING	1	27	924527	IDLER GEAR (18T)	3
7	9ST70007	VALVE STEM	1	28	9ST70028	IDLER GEAR PIN	3
8	9OB-04	O-RING(3.5*1.4)	1	29	920325-2	GEAR PLATE	1
9	9ST70009	AIR INLET	1	30	935030	CLAMP NUT	1
10	9ST70010A	EXHAUST SLEEVE	1	31	924531	BEARING (6200ZZ)	2
11	9ST70011	O-RING (26.7*1.78)	1	32	920117	CRANK SHAFT	1
12	970432	SPRING PIN	1	33	920118	CAM	1
13	970013BK	LEVER	1	34	920119	HEAD CAP	1
14	9ST70014	RUBBER	1	35	920120	BUSHING	1
15	9ST70015	HOUSING	1	36	920121	HEAD	1
16	920312	BEARING (696ZZ)	1	37	920122	SLIDE SPINDLE	1
17	9ST70017	REAR PLATE	1	38	935038A	PUNCH	1
18	9ST70018	PIN	2	39	935039A	SCREW	1
19	920019	ROTOR BLADE	4	40	935040A	DIE	1
20	935020	ROTOR(6T)	1	41	935041	NUT	1
21	9ST70021	CYLINDER	1				

**Limited Warranty**

Florida Pneumatic warrants its tools to be free from defects in material and workmanship for two years from the date of purchase. This warranty does not apply to tools which have been abused, misused, modified or repaired by someone other than Florida Pneumatic or its authorized service centers. If a Florida Pneumatic proves defective in material of workmanship within one year after purchase, return it to any authorized service center or to Florida Pneumatic, freight prepaid. Please enclose your name, address and adequate proof of purchase date with a brief description of the defect. Florida Pneumatic will, at its option, repair or replace defective tools, free of charge. Repairs or replacements are warranted as described above for the remainder of the warranty period. Florida Pneumatic's sole liability and your exclusive remedy under this warranty is limited to repair or replacement of the defective tool. There are no other warranties expressed or implied and Florida Pneumatic shall not be liable for incidental, consequential or special damages, or any other damages, costs or expense of repair or replacement as described above.