

Dana Point II 5 Pc. Set—  
Dana Point II 44 " Square Glass Top Table

Owner's Manual

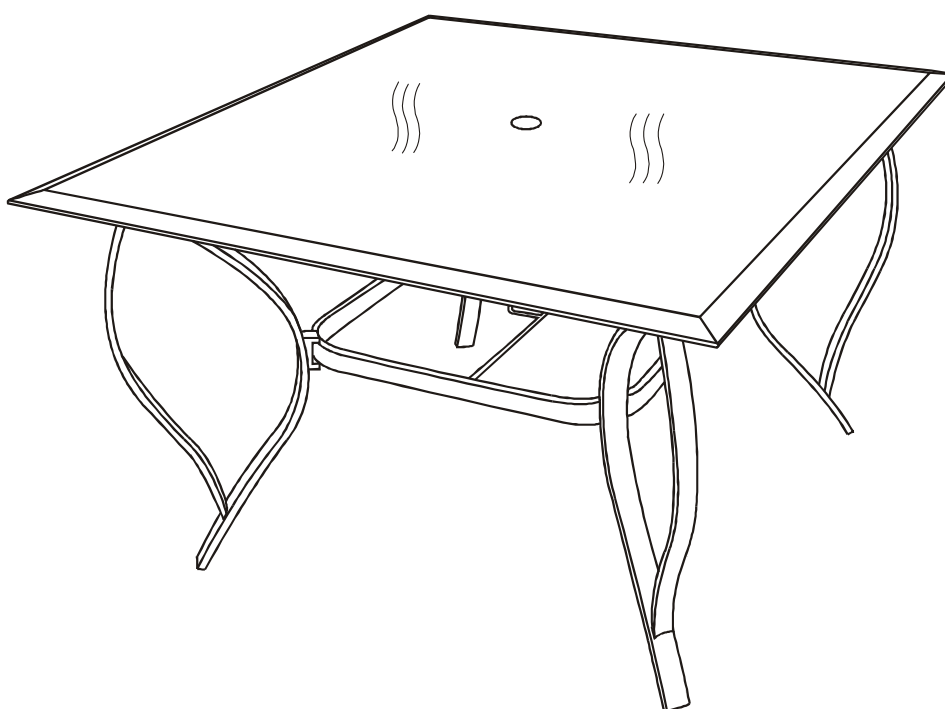

If you have any problems with this product, DO NOT RETURN IT TO THE STORE .

CALL OUR CUSTOMER SERVICE HOT-LINE AT

866-851-3006

8am-8pm (EST), Monday-Friday

## WARRANTY

**This warranty is a limited warranty, and applies to the original purchase only. Proof of purchase is required. This is a residential warranty and does not apply to commercial use. This collection carries a 5 year limited warranty and is valid from original date of purchase to the original owner (proof of purchase required): NOTE: Glass breakage is not a warranted item.**

### **Frame (Cast, Extruded Aluminum) – 5 Years**

If the furniture frame fails structurally (i.e. broken frame or welds) within 5 years from the purchase date, we will replace in the original color and style, if available or in a similar color and style if the original has been discontinued. Damage to frames or welds due to freeze damage and/or improper assembly are not covered.

### **Frame (Steel, Wrought Iron) – One Year**

Wrought Iron and steel furniture is warranted for (1) year from the original purchase date against defects in manufacturing and/or workmanship. **NOTE:** Steel and wrought iron are not warranted for rust, corrosion, or rust staining.

### **Wicker Weave (Resin) and/or Straps – One Year**

Straps and/or wicker weave shall be warranted against separation or breaking for one (1) year from the date of purchase. Discoloration and /or fading due to exposure to elements, chemicals or harsh cleaning products are not covered.

### **Powder Coat and/or Paint – One Year**

Finishes shall be warranted against blistering, cracking, or peeling for a period of one (1) year from the original date of purchase. We will replace in the original color and style, if available or in similar color and style if the original has been discontinued. Scratches, chips, and abrasion due to normal wear and tear are not covered.

### **Fabrics and Cushions – One Year**

All fabrics and cushions shall be warranted against separation at the seams for a period of one (1) year from the original date of purchase by the initial consumer. We will repair or replace any cushion or fabric in the original color and style, if available, or in similar color and style if the original has been discontinued. Fading or discoloration due to exposure to harsh chemicals is not covered.

### **Umbrellas – One Year**

Umbrellas are warranted against failure structurally within one year from the date of purchase, due to manufacturer's defects only. Umbrella bases are not covered. **Note: Umbrellas should only be used with a table and umbrella base. Do not use in high wind or storms.**

### **Component Parts – One Year**

If a component part fails due to manufacturing defects within one (1) year from the date of purchase, we will, replace the part.

### **Alternative Stone Tops – One Year**

Tops are warranted for one (1) year against defects in manufacturing and/or workmanship.

### **Shipping**

If required, we will pay for shipping of replacement products for the period of one (1) year from the date of purchase. After (1) year it will be the original purchasers' responsibility to pay for freight and packaging.

### **Exclusions**

Failure caused by unreasonable or abusive use, fire, freight damage, acts of nature (such as, but not limited to freezing or high winds), suntan oil or other chemicals, normal fading, scratching or chipping of the finish, fading, weathering or staining or discoloration of furniture, accidental damage, repair, or modifications by customer, glass breakage, normal wear and tear are excluded from the warranty.

Furniture used in commercial, contract or any other non-residential applications; clearance items, display models, and all other as is purchased items are not covered under this warranty. In addition, BJI, Inc. will not be responsible for loss of use or time, inconvenience, travel, packaging, or any other consequential/incidental damages. In no event shall BJI, Inc.'s responsibility exceed the value of the replacement part/product.

### **Care and Maintenance**

Be careful to never allow water to build up in frames as this will cause corrosion and freeze damage in cold climates. Wash all frames with a solution of mild soap and water. Rinse with clean water and dry with a soft absorbent cloth towel. Frames can be treated with a liquid wax for maximum protection against UV rays and/or salty damp air. If your set includes cushions, slings, and/or an umbrella they may be cleaned by hand with a solution of soap and water with a clean water rinse. (Never machine wash cushions, slings or umbrella covers as this will result in shrinkage or damage).

After cleaning cushions tip on end and allow to drip dry. (Never use a commercial or home dryer to tumble dry fabric goods). Do not use bleach or solvents to clean any product! This will void the warranty.

**Lack of original receipt will void warranty!**

### **Customer Service: Monday-Friday 8:00 a.m.-8:00 p.m. EST**







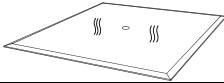

By FAX: 502-410-0702

By PHONE: 866-851-3006

Address: 2700 Stanley Gault parkway, Suite 130, Louisville, KY, 40223

**CAUTION:** Read all the instructions before assembly. Failure to do so may result in faulty assembly and potential injury!  
 Assemble product on a soft, non-abrasive surface such as a carpet or cardboard to avoid damaging the item. Seek assistance to assemble bulky or heavy items. After final alignment, make sure all bolts and nuts are securely tightened with screw head covers pressed in place.

**PARTS LIST**

Item	Part Name	Picture	Qty
A	Table Rim with Glass		1
B	Connector Ring		1
C	Table Leg		4
D	Hex Head Bolt M6*25mm		4
E	Hex Head Bolt M6*20mm		8
F	Washer (M6)		12
G	Bolt Cap		12
H	Wrench		1

**Don't tighten Bolts until Product is completely assembled.**

- Step 1. Take the plastic glass clamp off from the Table Rim (A), then take the glass top away from the Table Rim and place the Glass top on a soft surface carefully.
- Step 2. Turn the Table Rim (A) upside down (See figure 1)
- Step 3. Assembly the Table Legs (C) to Table Rim (A) with Bolts (D) and Washer (F) by using Wrench (H) (shown in figure 1).
- Step 4. Assembly the Leg Connector ring (B) to Table Legs (C) with Bolts (E) and Washer (F) by using Wrench (H) (show in figure 1).
- Step 5. Tighten all bolts with Wrench (H).
- Step 6. Cover all bolt heads with bolt Caps (G) provided.
- Step 7. Verify all bolts are securely tightened before use.

Figure 1

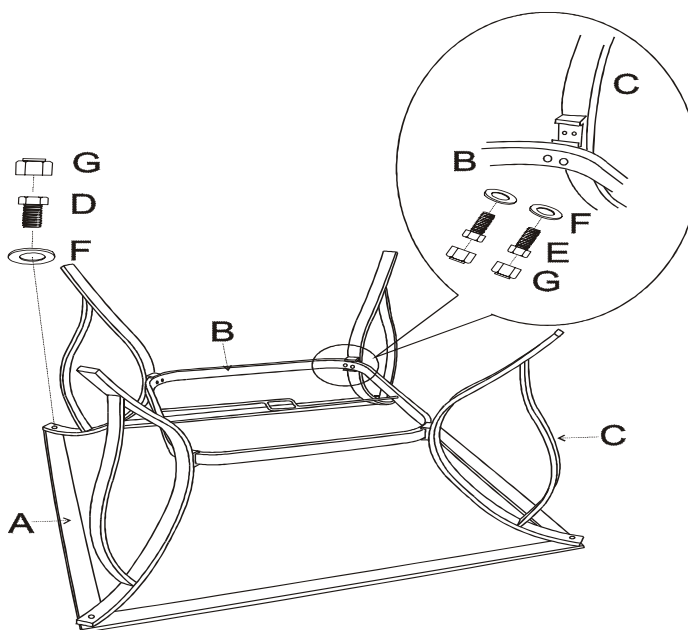

Step 8. Turn your table right side up, Place the glass top on the table rim carefully. (See Figure 2)

**Now your table is ready for enjoyment!**

**WARNING:**

1. Do not crawl, stand, or sit on glass table tops.
2. Do not set or lay heavy items on glass table tops.
3. Avoid extreme hot & cold items being placed on glass table tops.
4. This glass table top is produced with tempered glass which is designed to safely shatter in small pieces when impacted or stressed beyond strength limitations.

Figure 2

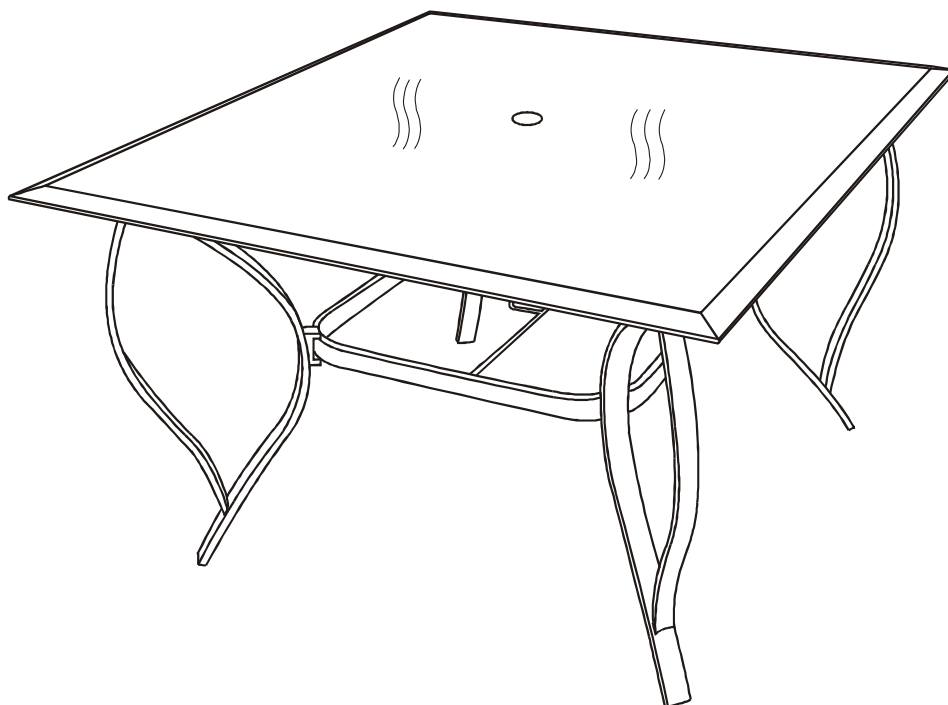

Dana Point II 5 Pc. Set—  
Dana Point II Sling Swivel rocker

Owner's Manual

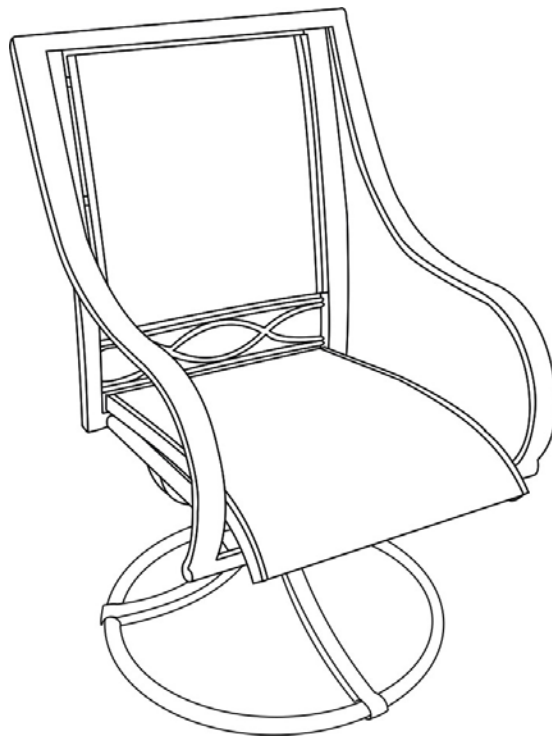

If you have any problems with this product, DO NOT RETURN IT TO THE STORE.

CALL OUR CUSTOMER SERVICE HOT-LINE AT

866-851-3006

8am-8pm (EST), Monday-Friday

Page 1 of 4

## WARRANTY

**This warranty is a limited warranty, and applies to the original purchase only. Proof of purchase is required. This is a residential warranty and does not apply to commercial use. This collection carries a 5 year limited warranty and is valid from original date of purchase to the original owner (proof of purchase required):**  
**NOTE: Glass breakage is not a warranted item.**

### **Frame (Cast, Extruded Aluminum) – 5 Years**

If the furniture frame fails structurally (i.e. broken frame or welds) within 5 years from the purchase date, we will replace in the original color and style, if available or in a similar color and style if the original has been discontinued. Damage to frames or welds due to freeze damage and/or improper assembly are not covered.

### **Frame (Steel, Wrought Iron) – One Year**

Wrought Iron and steel furniture is warranted for (1) year from the original purchase date against defects in manufacturing and/or workmanship. **NOTE:** Steel and wrought iron are not warranted for rust, corrosion, or rust staining.

### **Wicker Weave (Resin) and/or Straps – One Year**

Straps and/or wicker weave shall be warranted against separation or breaking for one (1) year from the date of purchase. Discoloration and /or fading due to exposure to elements, chemicals or harsh cleaning products are not covered.

### **Powder Coat and/or Paint – One Year**

Finishes shall be warranted against blistering, cracking, or peeling for a period of one (1) year from the original date of purchase. We will replace in the original color and style, if available or in similar color and style if the original has been discontinued. Scratches, chips, and abrasion due to normal wear and tear are not covered.

### **Fabrics and Cushions – One Year**

All fabrics and cushions shall be warranted against separation at the seams for a period of one (1) year from the original date of purchase by the initial consumer. We will repair or replace any cushion or fabric in the original color and style, if available, or in similar color and style if the original has been discontinued. Fading or discoloration due to exposure to harsh chemicals is not covered.

### **Umbrellas – One Year**

Umbrellas are warranted against failure structurally within one year from the date of purchase, due to manufacturer's defects only. Umbrella bases are not covered. **Note: Umbrellas should only be used with a table and umbrella base. Do not use in high wind or storms.**

### **Component Parts – One Year**

If a component part fails due to manufacturing defects within one (1) year from the date of purchase, we will, replace the part.

### **Alternative Stone Tops – One Year**

Tops are warranted for one (1) year against defects in manufacturing and/or workmanship.

### **Shipping**

If required, we will pay for shipping of replacement products for the period of one (1) year from the date of purchase. After (1) year it will be the original purchasers' responsibility to pay for freight and packaging.

### **Exclusions**

Failure caused by unreasonable or abusive use, fire, freight damage, acts of nature (such as, but not limited to freezing or high winds), suntan oil or other chemicals, normal fading, scratching or chipping of the finish, fading, weathering or staining or discoloration of furniture, accidental damage, repair, or modifications by customer, glass breakage, normal wear and tear are excluded from the warranty.

Furniture used in commercial, contract or any other non-residential applications; clearance items, display models, and all other as is purchased items are not covered under this warranty. In addition, BJI, Inc. will not be responsible for loss of use or time, inconvenience, travel, packaging, or any other consequential/incidental damages. In no event shall BJI, Inc.'s responsibility exceed the value of the replacement part/product.

### **Care and Maintenance**

Be careful to never allow water to build up in frames as this will cause corrosion and freeze damage in cold climates. Wash all frames with a solution of mild soap and water. Rinse with clean water and dry with a soft absorbent cloth towel. Frames can be treated with a liquid wax for maximum protection against UV rays and/or salty damp air. If your set includes cushions, slings, and/or an umbrella they may be cleaned by hand with a solution of soap and water with a clean water rinse. (Never machine wash cushions, slings or umbrella covers as this will result in shrinkage or damage).

After cleaning cushions tip on end and allow to drip dry. (Never use a commercial or home dryer to tumble dry fabric goods).

Do not use bleach or solvents to clean any product! This will void the warranty.











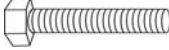
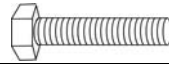

**Lack of original receipt will void warranty!**

**Customer Service: Monday-Friday 8:00 a.m.-8:00 p.m. EST**

By FAX: 502-410-0702  
 By PHONE: 866-851-3006  
 Address: 2700 Stanley Gault parkway, Suite 130, Louisville, KY, 40223

**CAUTION:** Read all the instructions before assembly. Failure to do so may result in faulty assembly and potential injury!  
 Assemble product on a soft, non-abrasive surface such as a carpet or cardboard to avoid damaging the item. Seek assistance to assemble bulky or heavy items. After final alignment, make sure all bolts and nuts are securely tightened with screw head covers press in place.

**PARTS LIST**

Item	Part Name	Picture	Qty
A	Seat Frame and Back		1
B	Seat		1
C	T-Rocker		1
D	Base		1
E	Hex Head Bolt M6X15mm		2
F	Hex Head Bolt M6X40mm		2
G	Hex Head Bolt M8X45 mm		4
H	Steel Washer (M6)		4
I	Spring Washer (M8)		4
J	Nut (M8)		4
K	Hex Head Cap (M6)		2
L	Hex Head Cover (M8)		4
M	Open Wrench		1
N	Combine Wrench		1

**Don't tighten Bolts until Product is completely assembled.**

Step 1. Attach the Seat (B) to chair Frame and Back (A) With Bolts M6X40 (F), Bolt M6X15 (E) and Steel Washers (H), as Figure 1.

Figure 1

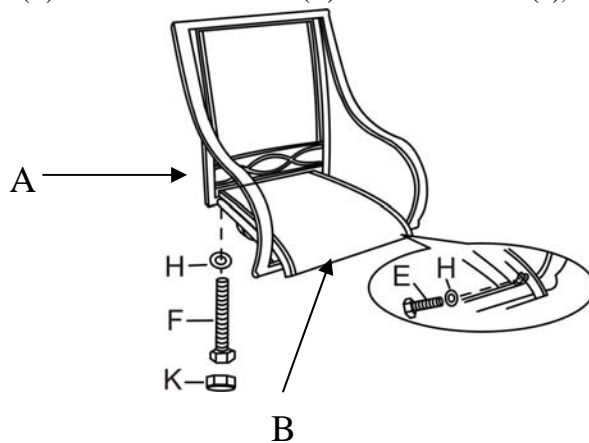

Step 2 .Attach the T-Rocker (C) to chair Frame and Back (A) With Bolts M8X45 (G), Spring Washers (I), And nuts (J ). See Figure 2.

Note: Make sure the T-Rocker is assembled correctly. See Figure 2.

Step 3. Insert the chair Frame and Back (A) into Base (D) See Figure 3

Step 4 Tighten all bolt and nut with Wrench (M, N), Cover the Hex head with Caps (K, L).

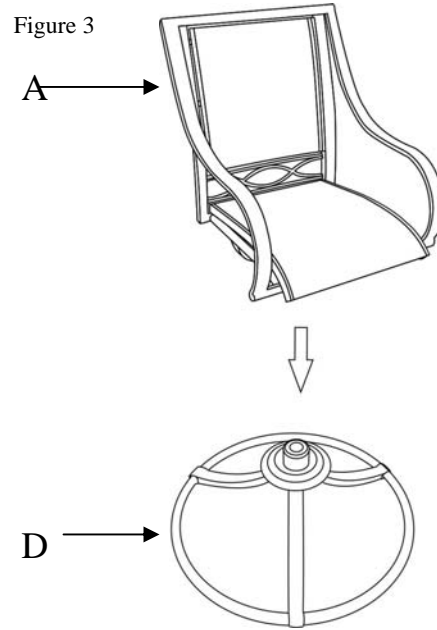
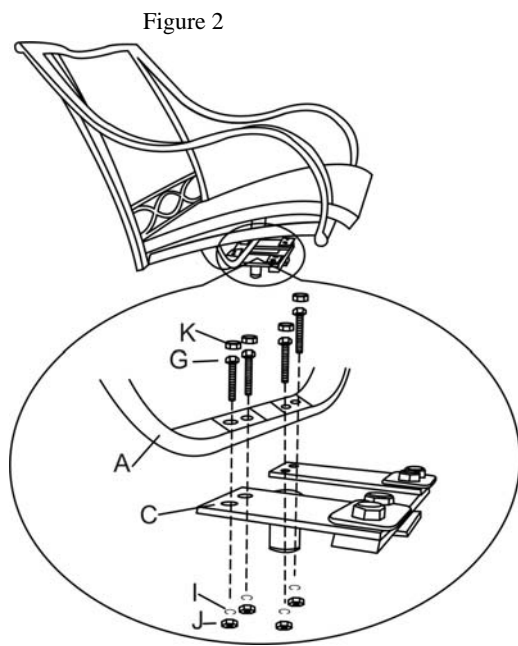

Step 5. Check and be sure the chair is assembled tightly and stable before you use.

Please check that all nuts are tight periodically

**Now the chair is ready for your enjoyment.**

