

Model Numbers: MCAC0008US, MCAC0009US, MCAC0008CN, MCAC0009CN,
MCAC3000US, MCAC3001US, MCAC3002US

EZcool & EZcool Duo

Owner's Manual

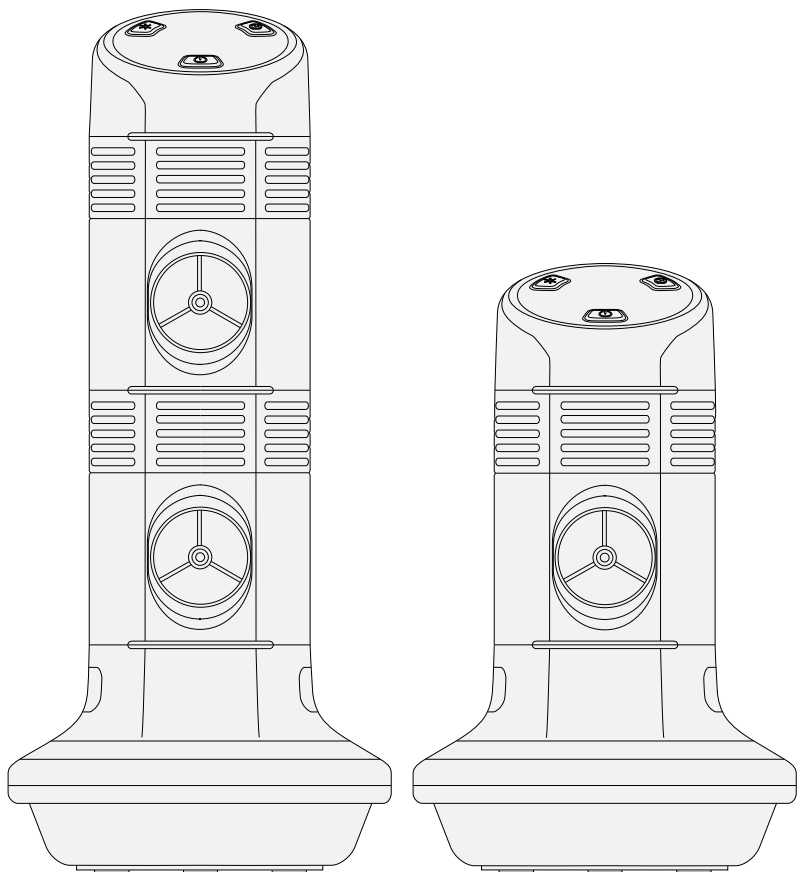

Thank you for choosing Lifesmart.
PLEASE READ THESE INSTRUCTIONS AND KEEP THIS
OWNER'S MANUAL IN A SAFE PLACE.



Table of Contents

	PAGE
Contents	2
Safety	2
Operation	3
Care	5
FAQ	10
Troubleshooting.....	11
Warranty	12

Package Contents

EZcool Evaporative Cooler
AC/DC Power Adapter
Quick Step Guide
Owner's Manual

Safety

READ AND SAVE THIS MANUAL FOR FUTURE REFERENCE.

WARNING: To reduce the risk of fire, electric shock, or injury:

1. Make sure that the power source complies with the electrical requirements of the product.
2. Do not use this product with damaged or missing filter(s).
3. If the product is not working correctly, has missing parts, has been dropped, damaged, or dropped in water, call 1-800-320-6478 for evaluation, adjustment, or repair.
4. To protect against electrical shock, do not immerse unit, plug, or cord in water or spray with liquids.
5. Keep the power cord away from heated surfaces.
6. Do not operate the product if the unit, power cord, or plug is damaged in any manner.
7. Do not run the cord under any carpets, throw rugs, runners, or similar coverings.
8. Do not route cord under furniture or appliances, and place cord away from trafficked area where it will not be tripped over.
9. Do not insert or allow any foreign objects to enter the intake or exhaust air openings.

10. Do not block or tamper with the atomizing nozzles, as it may reduce or impede the product's performance.
11. Disconnect the power cord before moving or performing any maintenance on the product.
12. This product must be grounded. Plug into an appropriate ground fault circuit interrupter (GFCI) protected outlet that is properly installed and in accordance with all local codes and ordinances.
13. Do not hang or mount the product on a wall or ceiling.
14. This product should not be used in potentially dangerous conditions, such as flammable, explosive, or chemically loaded atmospheres.
15. Do not store outside or near hazardous materials.

Operation

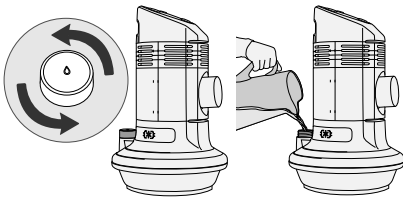

1. Remove tank cap and fill water tank (with potable water only) to the bottom of the fill basket. (approximately one gallon)

NOTE: Do not overfill tank.

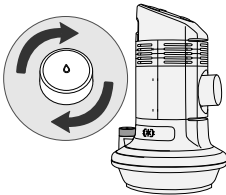

2. Replace cap and tighten until fully sealed.

NOTE: Unit will not function properly if cap is not tight.

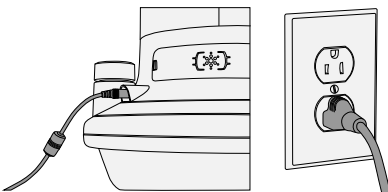

3. Plug AC/DC power adapter supply into the power port on the unit. Plug the three-pronged plug into an outlet.

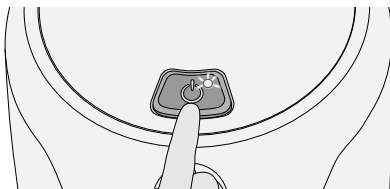

4. Press the POWER button at the top of the unit to turn on the evaporative cooler. Green light will illuminate.

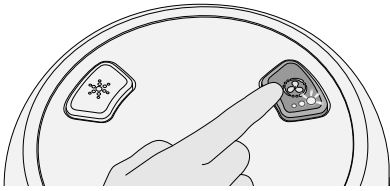

5. Press the FAN button to turn on fan. Adjust air speed by pressing button: (high, med, low) Green light will illuminate.

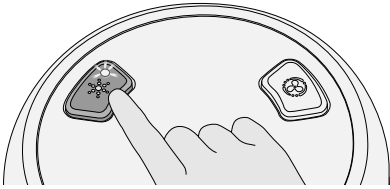

6. Press the COOL button to activate atomization. Green light will illuminate.

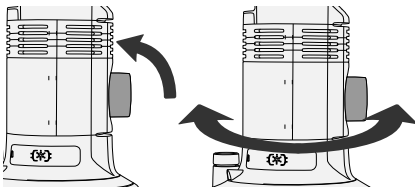

7. Adjust the cooling port(s) to the desired positions up-down and side-to-side.

POWER OFF

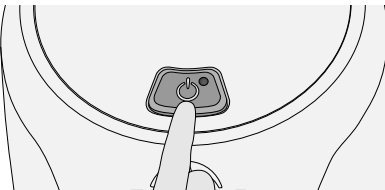

Press the POWER button to turn off. Green light will turn off.

NOTE: The EZcool evaporative cooler will continue to atomize for a short time while the unit depressurizes. Be sure to turn off product before unplugging.

Care

CLEANING & STORING PRODUCT



- Clean the cooler with a soft cloth and mild soap solution.

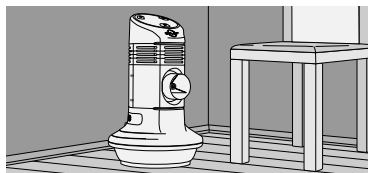

- Store the cooler in a clean and dry place.



No Water in System
When Storing

- DO NOT STORE COOLER WITH WATER IN THE SYSTEM FOR MORE THAN 5 DAYS.

EMPTYING WATER TANK

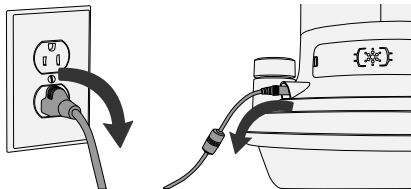

- Unplug the power supply.

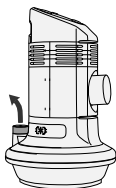
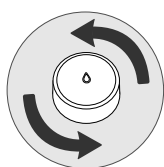

- Remove the water tank fill cap.

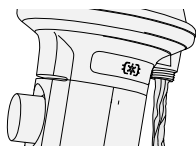

- Carefully turn the cooler over to allow water to drain out.

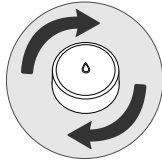
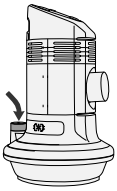

- Replace fill cap and turn until sealed.

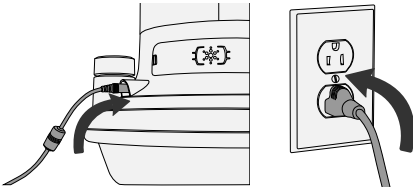

- Plug the cooler in and run COOL function until the atomized water stops.

CONDITIONING WATER TANK

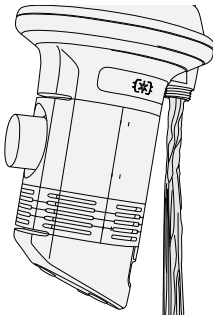

- If an unpleasant odor is detected, a quick conditioning of the water tank should correct the issue.
- Completely drain water tank. (See Emptying Water Tank)

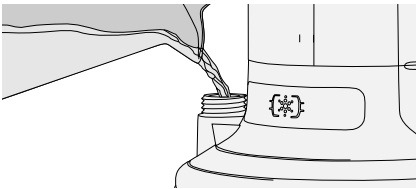

- Fill tank with 1 gallon of potable water.

NOTE: Do not overfill tank.

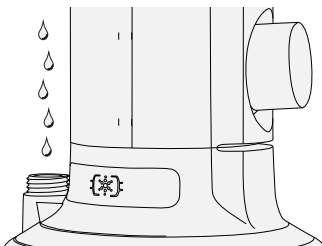

- Add 3 to 5 drops of unscented chlorine bleach to the full water tank.

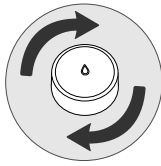
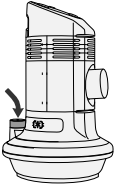

- Replace cap and turn until sealed.

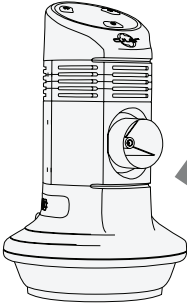

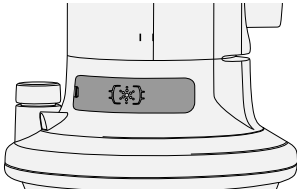

- The cooler is conditioned and ready for operation.

REPLACING FILTERS



NOTE: Each cooler has two filters:

*one for water 
and one for air *

- Locate the filter access doors on the sides of the cooler.

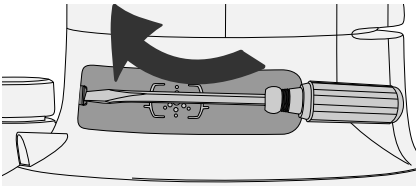

- Place small flathead screwdriver into slot on access door near back of unit and gently move the screwdriver towards back of unit until door can be removed.

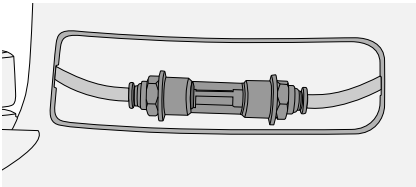

- The filters are connected to the tubing at the blue fittings.

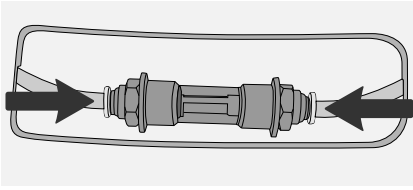

- Press the blue fittings towards the middle of the filter while gently pulling the tubing out of the filter.

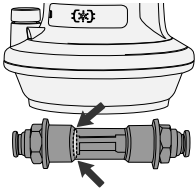

- Orient the red band in the new filter towards the rear of the cooler.

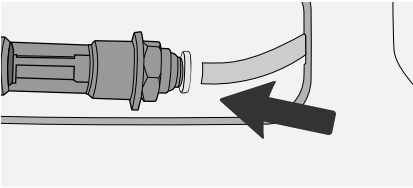

- Firmly insert tubing into the fittings on either side of the replacement filter.

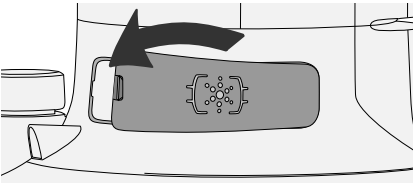

- Reinstall filter access door. Repeat steps for filter on opposite side.

Optimal Operating Placement

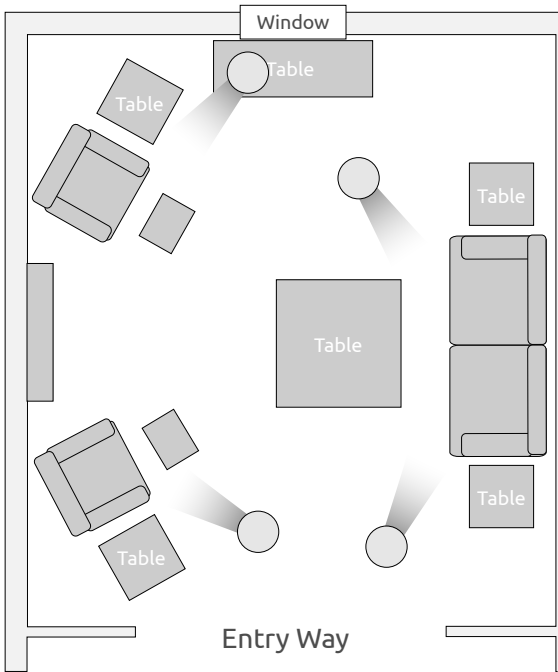

GOOD AREAS

- On floor with good airflow
example - by entryway of room
- Near open window
- On a table
- Directed towards user(s)

RECOMMENDED CLEARANCE

- 3 feet (0.9m) from front

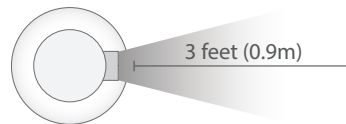

CAUTION: DO NOT COVER UNIT WITH FABRIC

FAQ

What is the run time with COOL on and how much water does it take?

EZcool – 10 + hours

EZcool Duo – 6 + hours

Both the EZcool and EZcool Duo will hold up to 1 gallon of water.

Can it be left outdoors?

It is not recommended to leave your cooler outside when it is not being used. (Think of it like a portable stereo - you can use it outdoors, but not recommended to leave outdoors.)

Where can you use the EZcool evaporative coolers?

The EZcool evaporative coolers were designed to be used both outdoors and indoors.

What type of water can you fill the cooler with?

You should use potable (drinkable) water.

Does ice water make it colder?

Water temperature does not noticeably impact the cooling performance.

What happens if the cooler runs out of water?

If the cooler runs out of water, it will simply stop atomizing water. No harm will be done by operating the cooler without water.

Where is the best place to use the unit?

(See Optimal Operating Placement Image on page 9)

Should there be a certain amount of space around the cooler?

Yes, there should be 3 feet of space in front of the port.
(See Recommended Clearance image on page 9)

Troubleshooting

PROBLEM	CAUSE	CORRECTION
Power button is not illuminating	<ul style="list-style-type: none"> a) POWER button is in the OFF position b) Power cord is not connected c) Wall outlet is not providing power 	<ul style="list-style-type: none"> a) Press POWER button one time b) Connect power cord and press POWER button one time c) Find an alternate power outlet
No air coming from port	FAN button is in the OFF position	Press FAN button to activate (high, med, low)
No atomization coming from port	<ul style="list-style-type: none"> a) COOL button is in the OFF position b) Water tank is empty c) Tank cap is not fully tightened d) Water filter is clogged 	<ul style="list-style-type: none"> a) Press COOL button one time b) Fill tank with water c) Tighten tank cap d) Replace water filter
Water streaming from nozzle(s) during shutdown	Water tank is overfilled	Open tank cap to release pressure. Drain tank to bottom of fill basket. During next start up the cooling function may stream water for a few seconds until the lines have been cleared.
Water streaming from nozzle(s) during operation	Air filter is clogged	Replace air filter

Warranty

1 YEAR LIMITED WARRANTY

The manufacturer warrants this unit against defects in materials and workmanship on functional parts, for a period of 1 year from the original date of purchase. Your sales receipt showing the date of purchase of the product is your proof of purchase. Keep it in a safe place for future reference.

This product is made with the highest quality materials and is warranted to be free from defects in materials and workmanship at the time of purchase. This limited warranty applies to products manufactured or distributed by the manufacturer, are delivered in the continental United States or Canada and extends to the original purchaser, or gift recipient. This warranty becomes valid at the time of purchase and terminates either by the specified time frame listed above and/or owner transfer. Any refunds or monetary compensations must be claimed through the place of purchase (retailer), and not through the manufacturer. Any extended warranties (warranties that cover above and beyond this manufacturer warranty) that are sold through a retailer or third party, are not directly correlated with this products' limited warranty, and may be redirected to said retailer or third party for coverage.

This warranty does not apply to the space cooler filters (air and water); these are expendable parts that require regular replacement to ensure optimal performance of your space cooler.

The purchaser may be asked to provide the supplier with proof of purchase documents (including the date of purchase) if requested. Any evidence of alteration, erasing, or forgery of proof of purchase documents will be just cause to VOID this limited warranty. Products, in which the serial number has been defaced or removed are not eligible for warranty coverage.

This warranty does not apply if the unit has been subject to negligence, fabrication, misuse, abuse, or repairs, alteration by non-manufacturer authorized personnel, inappropriate installations, or any case beyond the control of the manufacturer. Examples of warranty invalidation may also include, but are not limited to:

- Use of lacquer or paints in (and around) the unit.
- Normal wear/tear/weathering.
- Pet/consumer accidents.

The manufacturer shall not be liable for any loss due to use (or misuse) of the unit or other incidental or consequential costs, expense or damages without irrefutable foundations. Under no circumstances shall the manufacturer or any of its representatives be held liable for injury to any person or damage to any property, however arising. Any implied warranty shall have duration equal of the applicable warranty stated above. Specifications are subject to change without notice or obligation.

This limited warranty gives the original purchaser specific legal rights. Other rights may vary from state to state.