

Dana Point II Sling Double Glider

Owner's Manual

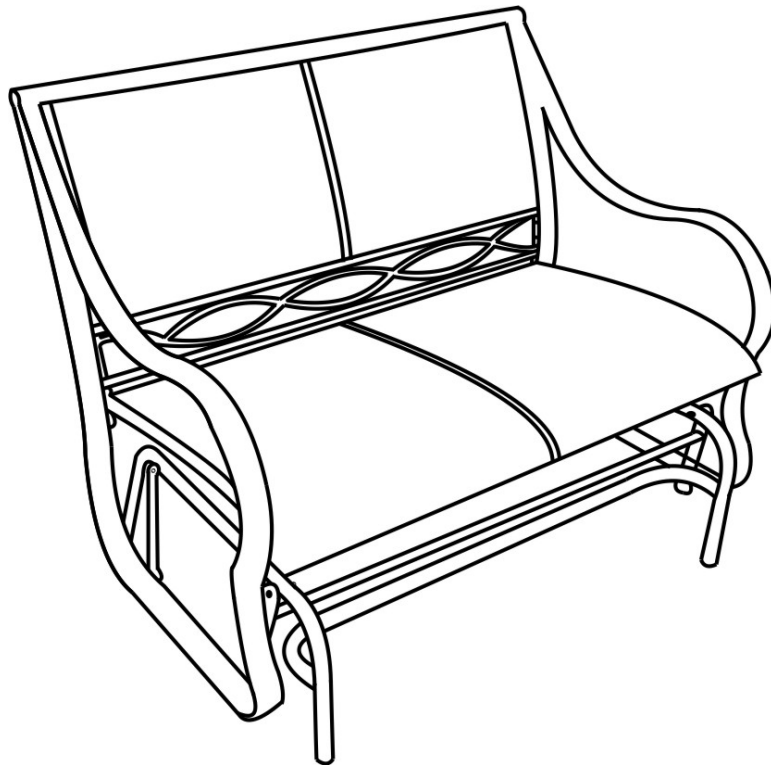

If you have any problems with this product, DO NOT RETURN IT TO THE STORE .

CALL OUR CUSTOMER SERVICE HOT-LINE AT

866-851-3006

8am-8pm (EST) ,Monday-Friday

WARRANTY

This warranty is a limited warranty, and applies to the original purchase only. Proof of purchase is required. This is a residential warranty and does not apply to commercial use. This collection carries a 5 year limited warranty and is valid from original date of purchase to the original owner (proof of purchase required): NOTE: Glass breakage is not a warranted item.

Frame (Cast, Extruded Aluminum) – 5 Years

If the furniture frame fails structurally (i.e. broken frame or welds) within 5 years from the purchase date, we will replace in the original color and style, if available or in a similar color and style if the original has been discontinued. Damage to frames or welds due to freeze damage and/or improper assembly are not covered.

Frame (Steel, Wrought Iron) – One Year

Wrought Iron and steel furniture is warranted for (1) year from the original purchase date against defects in manufacturing and/or workmanship. **NOTE:** Steel and wrought iron are not warranted for rust, corrosion, or rust staining.

Wicker Weave (Resin) and/or Straps – One Year

Straps and/or wicker weave shall be warranted against separation or breaking for one (1) year from the date of purchase. Discoloration and /or fading due to exposure to elements, chemicals or harsh cleaning products are not covered.

Powder Coat and/or Paint – One Year

Finishes shall be warranted against blistering, cracking, or peeling for a period of one (1) year from the original date of purchase. We will replace in the original color and style, if available or in similar color and style if the original has been discontinued. Scratches, chips, and abrasion due to normal wear and tear are not covered.

Fabrics and Cushions – One Year

All fabrics and cushions shall be warranted against separation at the seams for a period of one (1) year from the original date of purchase by the initial consumer. We will repair or replace any cushion or fabric in the original color and style, if available, or in similar color and style if the original has been discontinued. Fading or discoloration due to exposure to harsh chemicals is not covered.

Umbrellas – One Year

Umbrellas are warranted against failure structurally within one year from the date of purchase, due to manufacturer's defects only. Umbrella bases are not covered. **Note: Umbrellas should only be used with a table and umbrella base. Do not use in high wind or storms.**

Component Parts – One Year

If a component part fails due to manufacturing defects within one (1) year from the date of purchase, we will, replace the part.

Alternative Stone Tops – One Year

Tops are warranted for one (1) year against defects in manufacturing and/or workmanship.

Shipping

If required, we will pay for shipping of replacement products for the period of one (1) year from the date of purchase. After (1) year it will be the original purchasers' responsibility to pay for freight and packaging.

Exclusions

Failure caused by unreasonable or abusive use, fire, freight damage, acts of nature (such as, but not limited to freezing or high winds), suntan oil or other chemicals, normal fading, scratching or chipping of the finish, fading, weathering or staining or discoloration of furniture, accidental damage, repair, or modifications by customer, glass breakage, normal wear and tear are excluded from the warranty.

Furniture used in commercial, contract or any other non-residential applications; clearance items, display models, and all other as is purchased items are not covered under this warranty. In addition, BJI, Inc. will not be responsible for loss of use or time, inconvenience, travel, packaging, or any other consequential/incidental damages. In no event shall BJI, Inc.'s responsibility exceed the value of the replacement part/product.

Care and Maintenance

Be careful to never allow water to build up in frames as this will cause corrosion and freeze damage in cold climates. Wash all frames with a solution of mild soap and water. Rinse with clean water and dry with a soft absorbent cloth towel. Frames can be treated with a liquid wax for maximum protection against UV rays and/or salty damp air. If your set includes cushions, slings, and/or an umbrella they may be cleaned by hand with a solution of soap and water with a clean water rinse. (Never machine wash cushions, slings or umbrella covers as this will result in shrinkage or damage).

After cleaning cushions tip on end and allow to drip dry. (Never use a commercial or home dryer to tumble dry fabric goods).

Do not use bleach or solvents to clean any product! This will void the warranty.

Lack of original receipt will void warranty!

Customer Service: Monday-Friday 8:00 a.m.-8:00 p.m. EST

By FAX: 502-410-0702

By PHONE: 866-851-3006











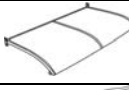

Address: 2700 Stanley Gault parkway, Suite 130, Louisville, KY, 40223

CAUTION: Read all the instructions before assembly. Failure to do so may result in faulty assembly and potential injury!

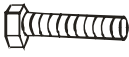
Assembly product on a soft, non-abrasive surface such as a carpet or cardboard to avoid damaging the item. Seek assistance to assemble bulky or heavy items. After final alignment, make sure all bolts and nuts are securely tightened with screw head covers press in place.

PARTS LIST

Figure 1

Item	Part Name	Picture	Qty
A	Left Arm		1
B	Right Arm		1
C	Seat		1
D	Back		1
E	Base		1
F	Hex Head Bolt M6X15mm		4
G	Allen Head Bolt M6X20mm		8
H	Hex Head Bolt M6X45mm		4
I	Steel Washer (M6)		16
J	Plastic Space		4
K	Allen Head Cap		8
L	Hex Head Cap		8
M	Allen Wrench		1
N	Wrench		1

Don't tighten Bolts until Product is completely assembled.

Step 1. Attach Arm (A, B) to seat frame (C) and back (D) with bolts, washers as Figure1.

Figure 1

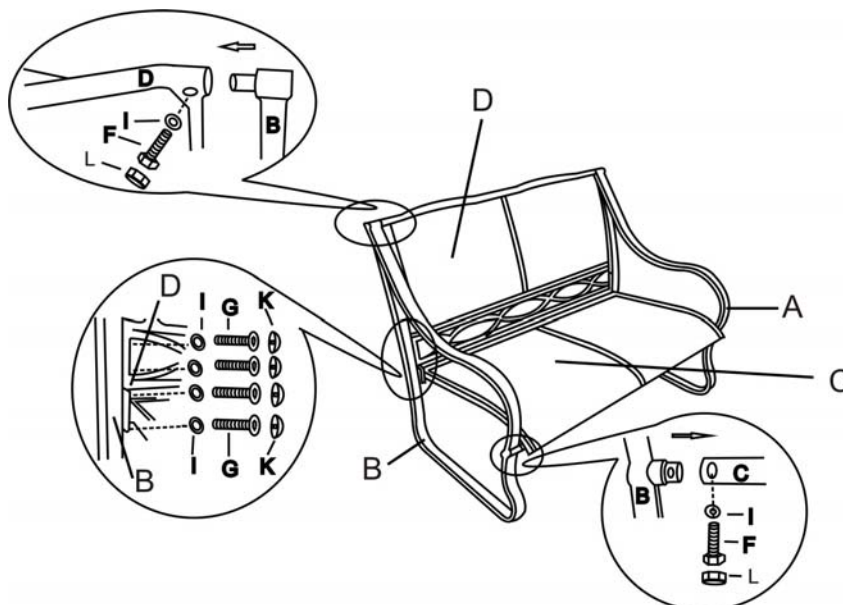

Step 2 Place back & seat assembled over base (E) Attach Hangers of Base (E) to Right Arm (B) and Left Arm (A) with Bolts (H), Steel washers (I) and Plastic Spaces (J), as Figure 2.

Step 3 Check the alignment, and adjust if necessary, if all are right, tighten all bolts and nut with wrench (M and N)).

Step 4 Cover the bolts and nuts with caps (K and L).

Now your glide is ready for your enjoyment.

Figure 2

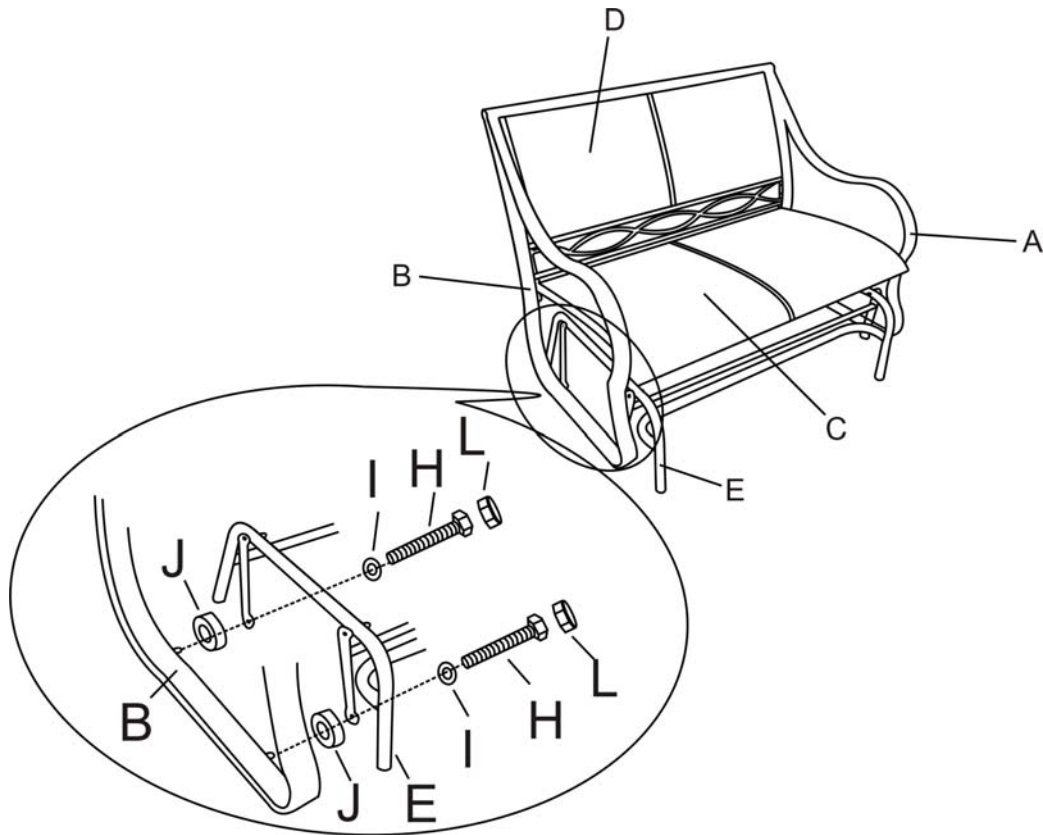

Figure 3

