

HE4011R0TX

“Chelmsford” Entry Mirror
Assembly Instructions



Southern
ENTERPRISES

For assistance with assembly,
contact:

Southern Enterprises Inc.
Customer Service 1-800-633-5096
service@seidal.com
www.seidal.com

PO#12639

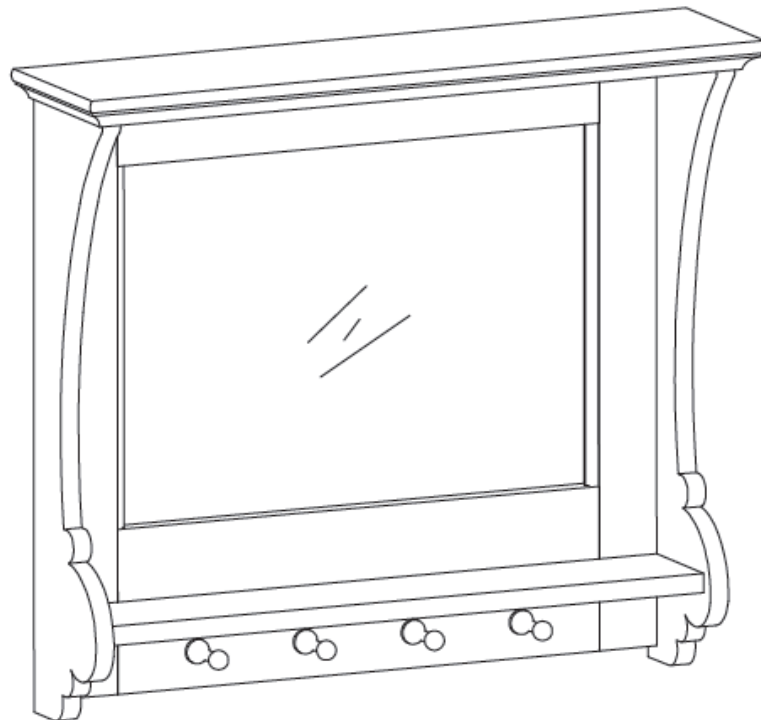









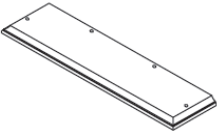
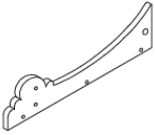
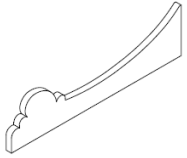
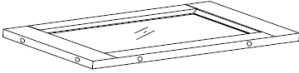
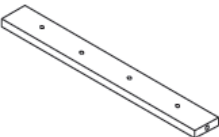
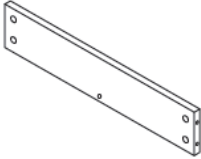

HE4011R0TX

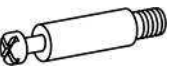
“Chelmsford” Entry Mirror

Parts List

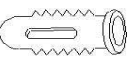
Please check packaging for all parts and hardware before discarding. Unpack and lay parts on clean, padded surface like carpet or blanket. Check that you have all parts indicated. Call customer service if hardware is missing. Before beginning assembly, carefully study the diagrams below and sort your hardware according to the pictures. Using the incorrect hardware will cause damage.

<p>A  Quantity Of 1</p> <p>Top Panel</p>	<p>B  Quantity Of 1</p> <p>Left Side Panel</p>	<p>C  Quantity Of 1</p> <p>Right Side Panel</p>
<p>D  Quantity Of 1</p> <p>Back Panel</p>	<p>E  Quantity Of 1</p> <p>Bottom Stretcher</p>	<p>F  Quantity Of 1</p> <p>Shelf</p>
<p>G  Quantity Of 4</p> <p>Hanger</p>	<p>H  Quantity Of 4</p> <p>Bolts $\phi 5/32$"x 25</p>	<p>I  Quantity Of 1</p> <p>Wrench</p>
<p>J  Quantity Of 17</p> <p>Cam Bolt $\phi 1/4$"x1-1/2"</p>	<p>K  Quantity Of 17</p> <p>Cam Lock $\phi 5/8$"x1/2"</p>	<p>L  Quantity Of 1</p> <p>Cam-Tool</p>
<p>M  Quantity Of 2</p> <p>Screws</p>	<p>N  Quantity Of 2</p> <p>Plastic Anchor</p>	<p>O  Quantity Of 6</p> <p>Cotton Mat</p>

Care and Cleaning Instructions:
 Before using, wipe with a clean, dry cloth. Periodically apply furniture wax to renew the finish. Avoid rubbing or scratching the surface with rough or abrasive objects.

Call customer service at 1-800-633-5096 for assistance, questions, or parts.

Assembly Tool Required
No.2 Phillips Screw Driver



HE4011R0TX “Chelmsford” Entry Mirror Assembly Instruction

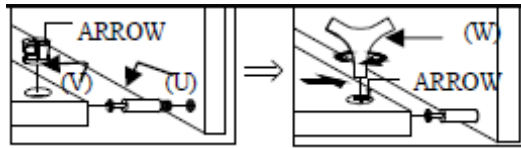

NOTE: Make sure the mounting holes on the back of Back Panel (D) are on the top part of the panel.

Step 1:

Rotate 3 Cam-Bolts (J) into corresponding holes in Cross-Panel (F).

Step 2:

Insert Cam-Bolts (J) into holes in panels (D) and (E) and secure using Cam-Locks (K).

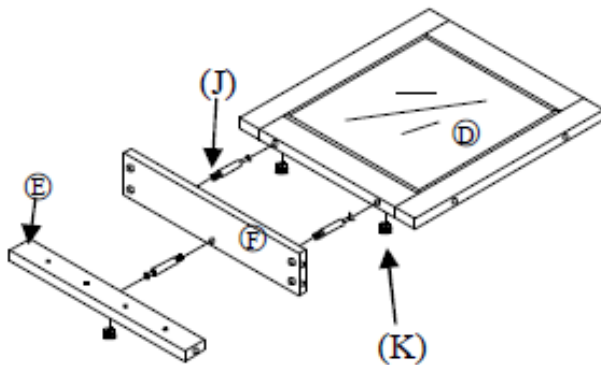

Figure 1

Step 3:

Rotate 10 Cam-Bolts (J) into holes in Side Panels (B) and (C).

Step 4:

Insert Cam-Bolts (J) into holes in panels (D), (E), (F) and secure using Cam-Locks (K).

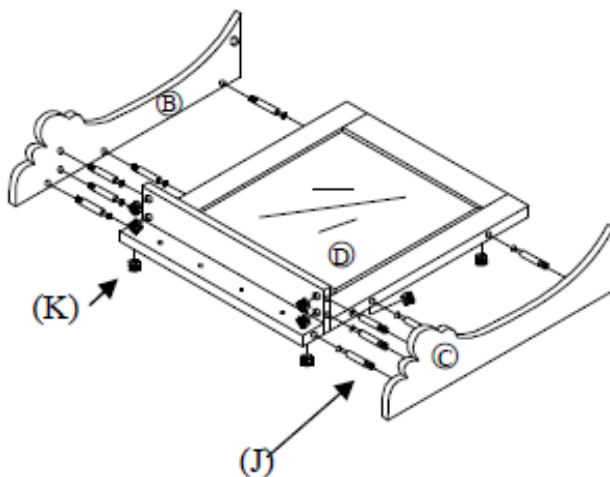

Figure 2

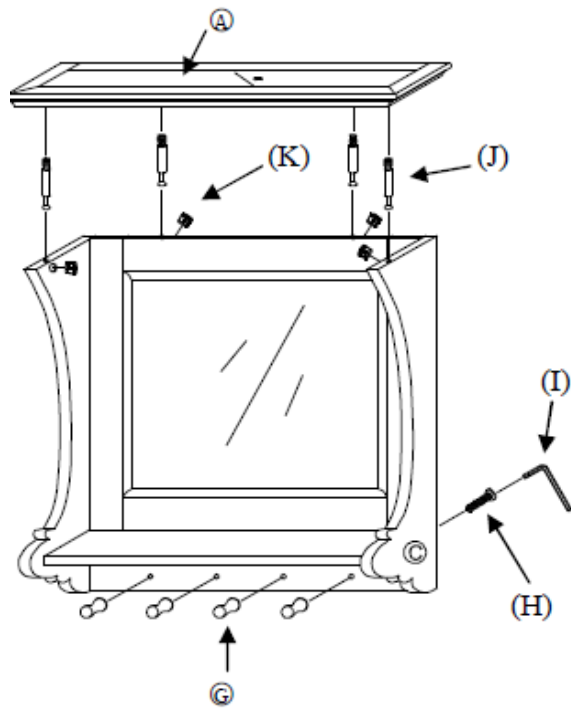

Figure 3

Step 5:

Rotate 4 Cam-Bolts (**J**) into holes in Top Panel (**A**).

Step 6:

Insert Cam-Bolts (**J**) into holes in panels (**B**), (**C**), (**D**) and secure using Cam-Locks (**K**).

Step 7:

Attach the 4 wooden pegs (**G**) to rear panel (**E**) using 4 screws (**H**) which are inserted through the back of panel (**E**).

Tighten using Allen Wrench (**I**).

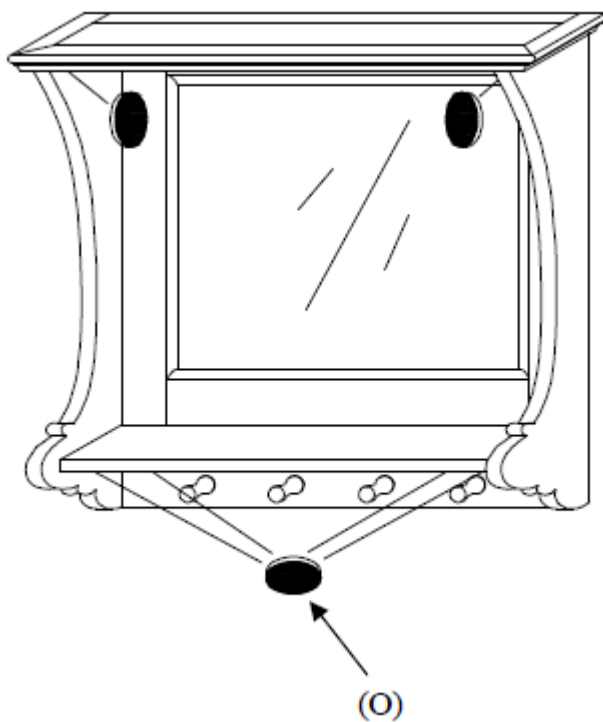

Figure

Step 8:

Cover Cam-Locks (**K**) with Cotton Mats (**O**) provided.

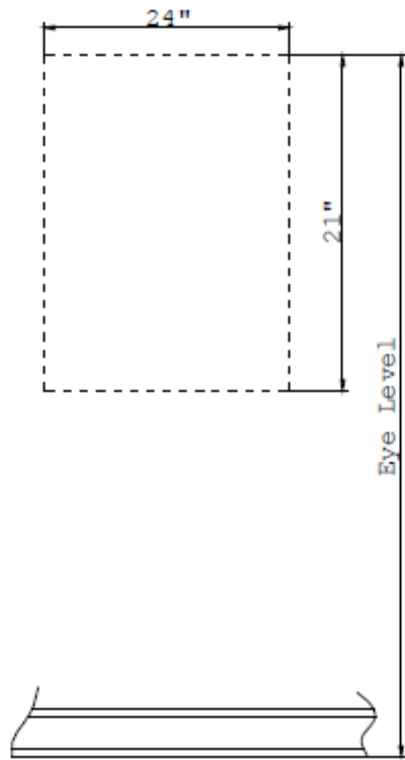

Figure 5

Step 9:

Locate the wall mirror on a solid wall and at a comfortable height off the floor, normally eye level.

Measure the wall and mark the wall mirror width and height. See Figure 5.

Please mount at least one screw directly into a wall stud. Wall anchor is not needed when mounting the screw directly into a wall stud.

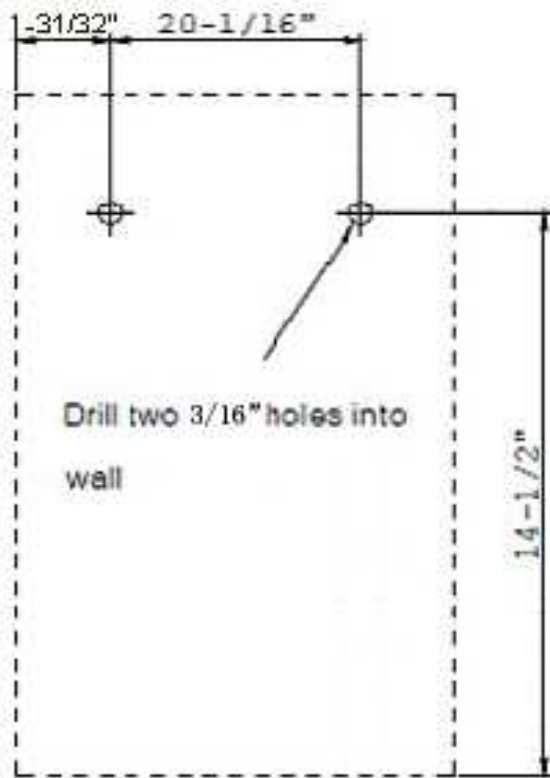

Figure 6

Step 10:

Measure the wall and mark the location of the center of each of the two screw mounting holes, see Figure 6.

Using the level, make sure that the two marks are level to the wall.

Using the power drill and 3/16 inch drill bit, drill two 3/16 inch holes through the wall board at the mounting hole marks.

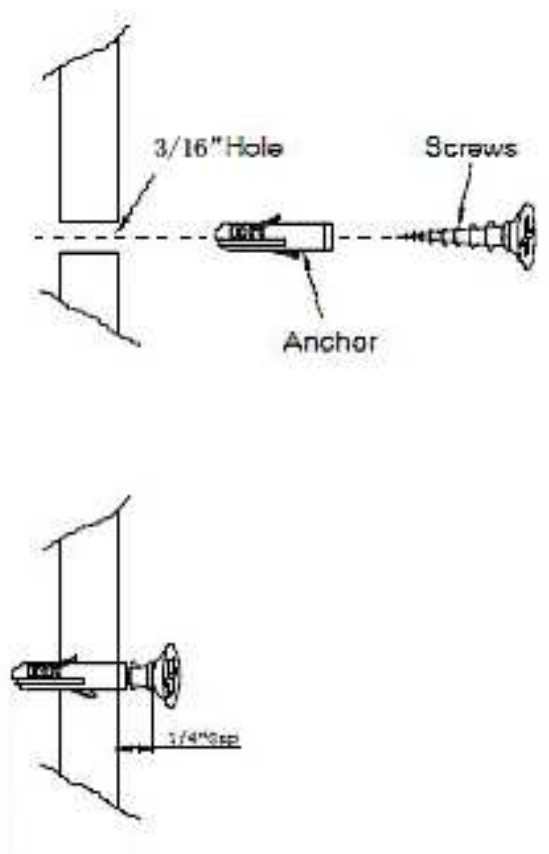

Figure 7

NOTE: Make sure not to drill into electrical wiring or plumbing pipes.

Step 11:
 Insert one of the plastic anchors into one of the two 3/16” holes, see Figure 7. Make sure that the wall anchor is flush with the wall.

NOTE: It may be necessary to use a small hammer to gently tap the anchor into place.

Step 12: Using the Phillips head screwdriver install one screw into each of the anchors, see Figure 7. Turn the screw in until there is a gap of 1/4” between the head of screw and the wall surface.

Figure 8

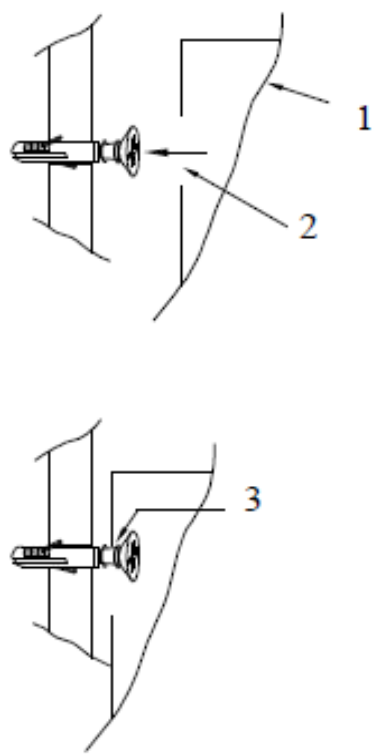

Step 13:
 Install the wall mirror (1, Figure 8) onto the two mounting screws using the mounting holes (2, Figure 8). The proper and secure mounting of the wall mirror is when the top edge of each of the mounting holes is resting securely on the mounting screw (3, Figure 8).

NOTICE
 Using the level, check to make sure that the wall mirror is horizontally level and vertically plumb (straight up and down).

Parts Replacement Form

Customer Information

Name

Address

City/State/Zip Code

Phone Number

Please indicate where you purchased this item: Store/Website/Catalog

Please indicate color/size/style number:

Style No Needed	Parts Letter	Parts Description	Quantity
--------------------	--------------	-------------------	----------

Please immediately examine this product carefully. Any request for missing parts or damage replacement must be received within 90 days of your receipt of the product. Replacement, if available, will be honored within this time frame. Parts will not be available for items arriving fully assembled. We do not recommend modifying product(s) and we are not responsible for any damages due to product modification(s). If damages or missing parts are not reported within 90 days of your receipt, we are under no obligation to provide parts or replacement merchandise.

Please contact Southern Enterprises at 800-633-5096 or in Dallas 972-869-0111/ 9am – 4pm Mon-Fri Central time if you have product issues or email us at service@seidal.com. Please ask for customer service representative for issues involving damages or replacement parts. Please ask for technical assistance representative for any issues with product and assembly/construction

Please contact the retailer that you purchased from for returns.

Customer Service 1-800-633-5096
service@seidal.com



Southern
ENTERPRISES

Southern Enterprises, Inc.
600 Freeport Parkway, Suite 200
Coppell, Texas 75019