



AGIO INTERNATIONAL COMPANY LTD.

SHUNDE SHIAN FURNITURE INDUSTRIES CO. LTD.

PATIO FURNITURE & ACCESSORIES ASSEMBLY INSTRUCTIONS



STOP - IMPORTANT

If you have any problems with this product (missing or damaged parts, assembly issues), please

DO NOT RETURN TO THE RETAILER/STORE

where you purchased the product. Call our Customer Service Hotline at:

1-800-416-3511

Between 9:00 AM and 5:00 PM Eastern Time, Monday through Friday

Or visit our website at: www.agio-usa.com

To expedite any future warranty claims, retain the instruction sheet, warranty card, and receipt for future use. you are encouraged to register your purchase on our website at www.agio-usa.com

For additional online video support on assembly, troubleshooting, and care and maintenance of your outdoor furniture, please visit our website at: www.agio-usa.com/support

ASSEMBLY INSTRUCTIONS

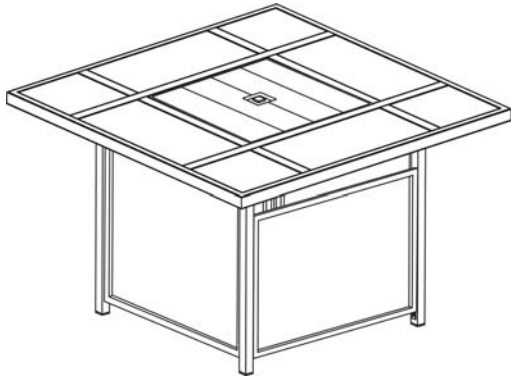

CSA Model 99010



ARL00200

Installer: Leave these instructions with consumer.

Consumer: Keep these instructions for future reference.

⚠ DANGER
 If you smell gas:

1. Shut off gas to the appliance.
2. Extinguish any open flame.
3. If odor continues, keep away from the appliance and immediately call your gas supplier or fire department.

⚠ WARNING:
 Improper installation, adjustment alteration, service or maintenance can cause injury or property damage. Read the installation, operating and maintenance instructions thoroughly before installing or servicing this equipment.

⚠ WARNING
 Do not store or use gasoline or other flammable vapors and liquids in the vicinity of this or any other appliance. An LP-cylinder not connected for use shall not be stored in the vicinity of this or any other appliance.

⚠ WARNING: For Outdoor Use Only

FOR USE WITH 20LB (9KG) PROPANE CYLINDER WITH TYPE 1 CONNECTION OR FOR USE WITH NATURAL GAS AFTER CONVERSION KIT IS INSTALLED (MUST BE PROFESSIONALLY INSTALLED) ALSO THE LP REGULATOR MUST BE SUPPLIED BY THE MANUFACTURER.

⚠ DANGER	CARBON MONOXIDE HAZARD
	<p>This appliance can produce carbon monoxide which has no odor.</p> <p>Using it in an enclosed space can kill you.</p> <p>Never use this appliance in an enclosed space such as a camper, tent, car or home.</p>

WARNING:
 USE FACTORY APPROVED REPLACEMENT PARTS AND ACCESSORIES ONLY. USE OF UNAPPROVED PART OR ACCESSORIES CAN VOID THE WARRANTY ON THIS PRODUCT AND RESULT IN A HAZARDOUS CONDITION. PLEASE CONTACT US FOR INFORMATION REGARDING REPLACEMENT HOSES, THERMOCOUPLES, ELECTRODES, IGNITION MODULES, LAVAROCKS, LOGS, FIRE ICE, ETC.



Questions, Problems, Missing Parts? Before returning to your retailer, call our customer service department in the US and Canada at 1-800-416-3511, Monday-Friday, 9 a.m.–5 p.m. Eastern Time.

TABLE OF CONTENTS

Important Safety Information	3
Important About Propane	4
Specifications	4
Parts Identification List	5-6
Installation	7-11
Batteries	11
Lighting Instructions	12
Maintenance	12
Troubleshooting Guide	13
Warranty	14

IMPORTANT SAFETY INFORMATION

The installation must conform with local codes or, in the absence of local codes, with the National Fuel Gas Code, ANSI Z223.1/NFPA 54; International Fuel Gas Code. ; Natural Gas and Propane Installation Code, CSA B149.1; or Propane Storage and Handling Code, B149.2, as applicable.

The appliance must be isolated from the gas supply piping system by closing its equipment shutoff valve during any pressure testing of the gas supply system at test pressure equal to or less than 1/2 psi (3.5kPa).

The appliance area must be kept clear and free from combustible materials, gasoline and other flammable vapors and liquids.

Do not use this appliance if any part has been under water. Immediately call a qualified service technician to inspect the appliance and to replace any part of the control system and any gas control which has been under water.

Children and adults should be alerted to the hazards of high surface temperatures and kept at a safe distance to avoid burns or clothing ignition.

Young children should be carefully supervised when they are anywhere near the appliance.

Clothing or other flammable material should not be hung from the appliance, or placed on or near the appliance.

Any screen or guard removed for servicing an appliance must be replaced prior to operating the appliance.

Installation and repair should be done by a qualified service person. The appliance should be inspected before use and at least annually by a professional service person. More frequent cleaning may be required as necessary. It is imperative that the control compartments, burners and circulating air passageways of the appliance be kept clean.

Do NOT burn solid fuels in this gas fireplace.

CAUTION: The propane gas pressure regulator provided with this appliance must be used. This regulator is set for an outlet pressure of 11 inches water column.

This outdoor gas appliance is not intended to be installed in or on recreational vehicles and/or boats.

Before each use of this gas appliance, open the LP (Liquid Propane) Tank Drawer and inspect the LP Hose. If there is evidence of excessive abrasion or wear, or the hose is cut, it must be replaced prior to the gas appliance being put into operation. Use only the replacement hose assembly specified in this manual. Inspect the burner before each use of the appliance. The burner must be replaced prior to the appliance being put into operation if it is evident that the burner is damaged. Use only the burner listed in these instructions.

Keep the fuel supply hose away from any heated surfaces.

IMPORTANT SAFETY INFORMATION ABOUT PROPANE (LP) GAS

A self contained LP-gas cylinder for use with this appliance must have a capacity of 20 lbs. and must be equipped with a Type 1 connector and an OPD (overfill protection device). See Figure 1.

The LP-gas supply cylinder to be used must be constructed and marked in accordance with the specification for LP-gas cylinders of the U.S. Department of Transportation (DOT) or the National Standard of Canada, *CAN/CSA-B339, Cylinder, Sphere and Tubes for the Transportation of Dangerous Goods*.

- The cylinder supply system must be arranged for vapor withdrawal.
- The cylinder used must include a collar to protect the cylinder valve.
- This appliance shall be used only outdoors in a well-ventilated space and shall not be used in a building, garage or any other enclosed space.
- When this appliance is not in use, the gas must be turned off at the supply cylinder.
- Storage of this appliance indoors is permissible only if the cylinder is disconnected and removed from the appliance.
- Cylinders must be stored outdoors in a well-ventilated area out of the reach of children. Disconnected cylinders must have threaded valve plugs tightly installed and must not be stored in a building, garage or any other enclosed areas.

CSA (Canadian Standards Association) certified to ANSI Z21.97•CSA 2.41-2012 “Outdoor Decorative Gas Appliances”

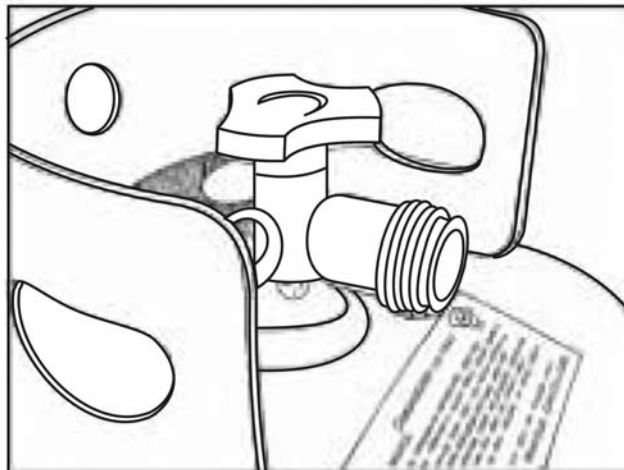











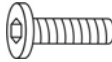
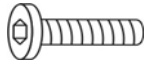







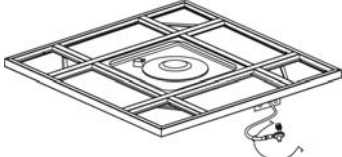
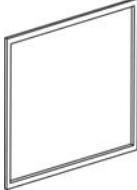
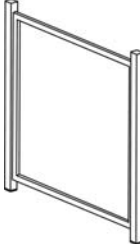





Figure 1

SPECIFICATIONS

INPUT	40,000 Btu/hr	30,000 Btu/hr Low fire
Propane Regulator Pressure	11 inches water column	
Clearances to combustible surfaces	Sides 24in./61cm	Top: 72 in. / 183 cm

PARTS IDENTIFICATION LIST

	PART	DESCRIPTION	PART#	QTY
A		CONTROL KNOB	FP1245	1
B		GAS VALVE	FP0307	1
C		THERMOCOUPLE	FP0004	1
D		LP REGULATOR HOSE	65-FP-0181	1
E		ELECTRODE	65-FP-0128	1
F		ORIFICE ELBOW	FP0310	1
G		IGNITION MODULE	FP0006	1
H		PROPANE ORIFICE	ZCF0021	1
I		"AAA" BATTERY(1.5V)	HW0705	1
J		LAVA ROCK SET	FP0002	1
K		FOOTCAP	FC0743	4
L		1/4" X 15 MM BOLT	HW0034	8
M		1/4" X 20 MM BOLT	HW0036	4
O		1/4" X 40 MM BOLT	HW0086	4
P		HEX BOLT DRIVER	HW0006	1
Q		BOLT COVER	HW0105	18
R		WASHERS-1	HW0004	14
S		WASHERS-2	HW0712	4
T		NUTS	HW0717	2
U		HEX BOLT DRIVER	HW0008	1

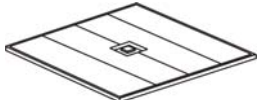
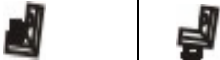
V		TABLE RIM		1
W		BACK PANEL		1
X		LEFT SIDE PANEL		1
Y		RIGHT SIDE PANEL		1
Z		DOOR PANEL		1
AA		LP SUPPORT		1
BB		TILE-1		4
CC		TILE-2		4
DD		MIDDLE SUPPORT		1
EE		TABLE COVER		1
FF		BOTTOM/ TOP CONNECTOR		1

INSTALLATION

1. Identify parts packed in carton against the parts list. Remove all protective materials and set parts on a flat, non-abrasive surface.
2. Attach the back panel to side panels by using four 1/4"x40 mm bolts and washers as shown in Figure 2. Guide bolts through holes in back panel, into pre-drilled holes in the side panels. **Hand tighten only.**

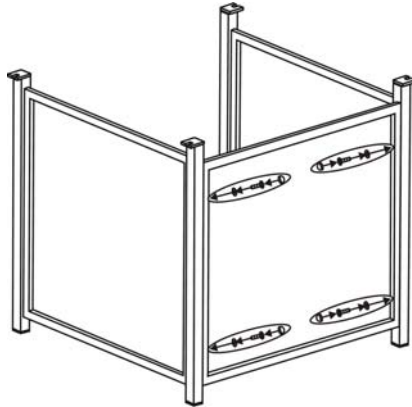

Figure 2

3. Attach the middle support to the side panels by using two 1/4"x15 mm bolts and washers as shown in Figure 3. Guide bolts through the holes in the middle support, into pre-drilled holes in the side panels. **Hand tighten only.**

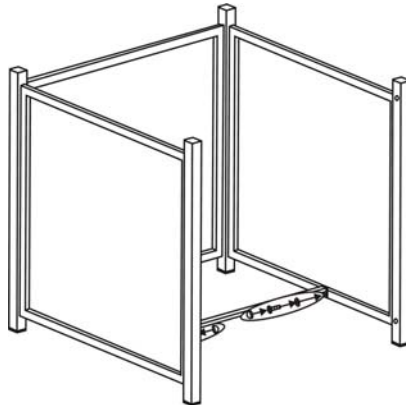

Figure 3

4. Attach the "L" connector to right side panel by using a 1/4"x15 mm bolt and washer as shown in Figure 4. Guide bolt through hole in "L" connector, into pre-drilled hole in the right side panel. **Do not over tighten.**

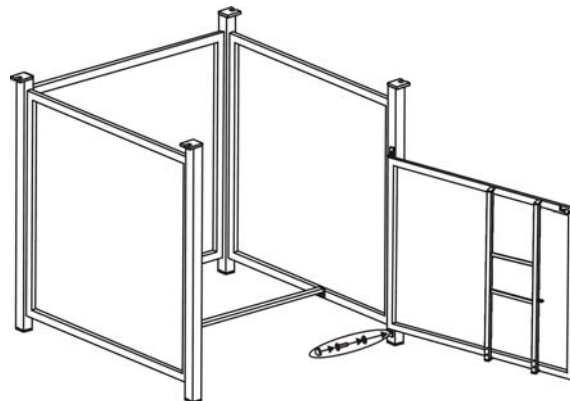

Figure 4

5. Put the door onto the "L" connector (pre-assembled), guide the pin on the lower "L" connector into the hole under the door. Then guide the pin on the upper "L" connector into the hole in the upper portion of the door. Use a 1/4"x15 mm bolt and washer to secure the "L" connector to the right side panel as shown in Figure 5. **Do not over tighten.**

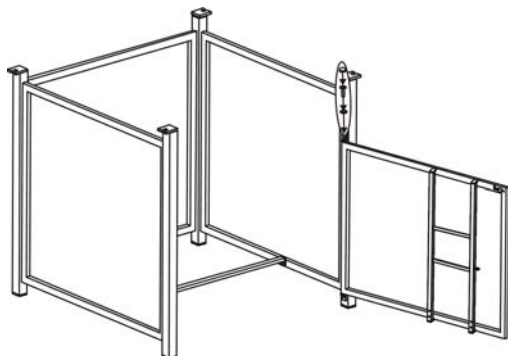

Figure 5

6. With the help of another person, carefully place the table top onto the table base. After making any necessary adjustments to the alignment of the table top and the assembled base, use four 1/4"x15 mm bolts and washers as shown in Figure 6. Guide the bolts through the holes under the table top, into the pre-drilled holes in the side panels. **Do not tighten completely.**

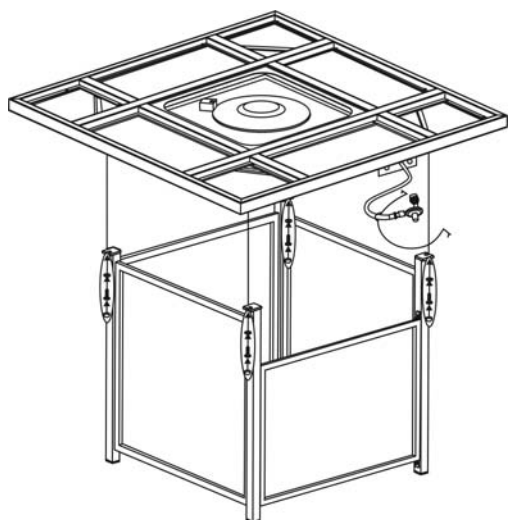

Figure 6

7. Attach the LP support to door panel by using four 1/4"x15 mm bolts and washers as shown in Figure 7. **Do not over tighten.**

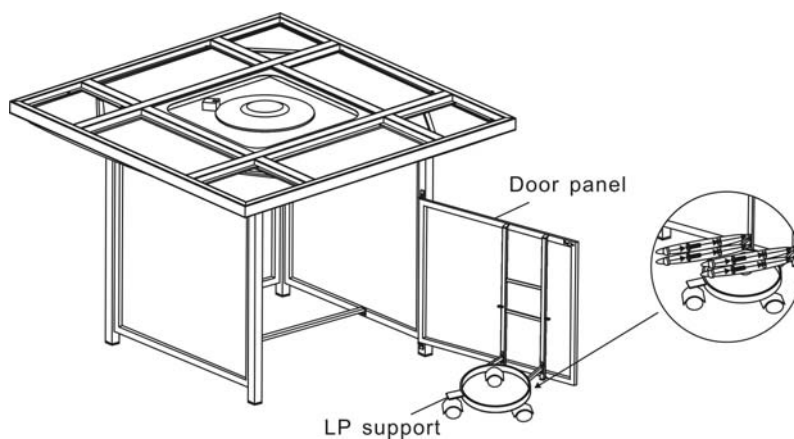

Figure 7

8. Place gas tank onto the LP support as shown in Figure 8.

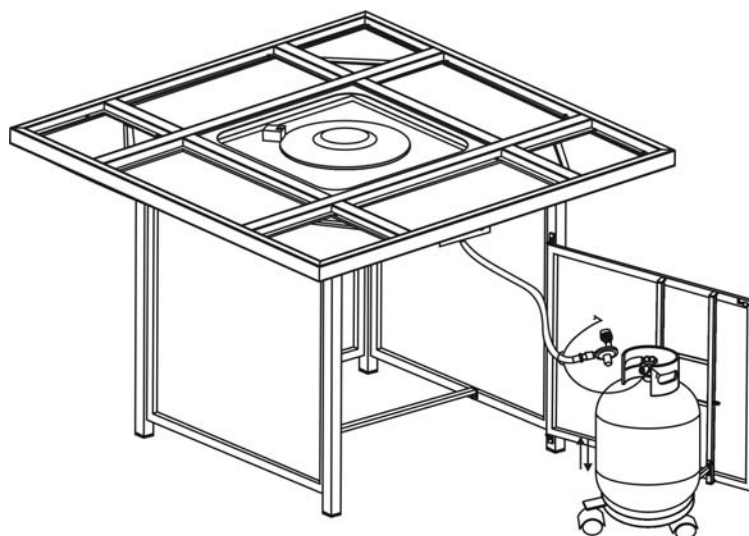

Figure 8

9. Attach the metal ring (as shown in Figure 9) pre-fitted with gas hose which is connected to the table top, into the hole of the door panel, then use hex bolt driver to screw 1/4"x5mm nut, the gas tank has fixed as shown in Figure 10. Connect the regulator as shown in Figure 10. Screw the black handle clock-wise to tighten. Turn the handle counterclockwise to remove. The hose must point down. Check that the valve is turned all the way clockwise to the "OFF" position.

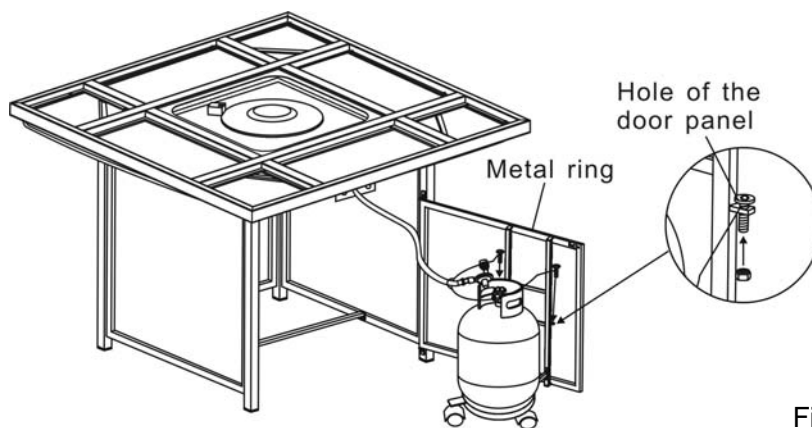

Figure 9

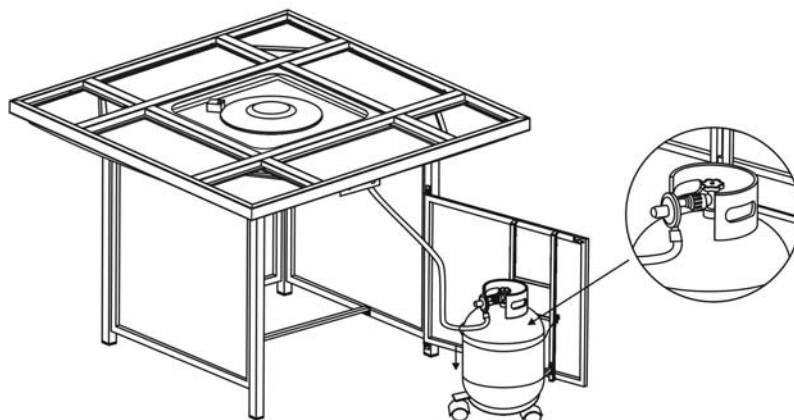

Figure 10

10. After making any necessary adjustments to the parts, use the hex bolt driver to tighten all bolts. Note: each bolt must be tightened a few revolutions at a time. Repeat until all bolts are tight. Do not over tighten. Over tightening may strip bolts. Cover all bolts with covers.
11. Note the clear bumpers spaced evenly throughout the inside of the table top. Carefully place tiles inside table rim, resting on the clear bumpers as shown in Figure 11

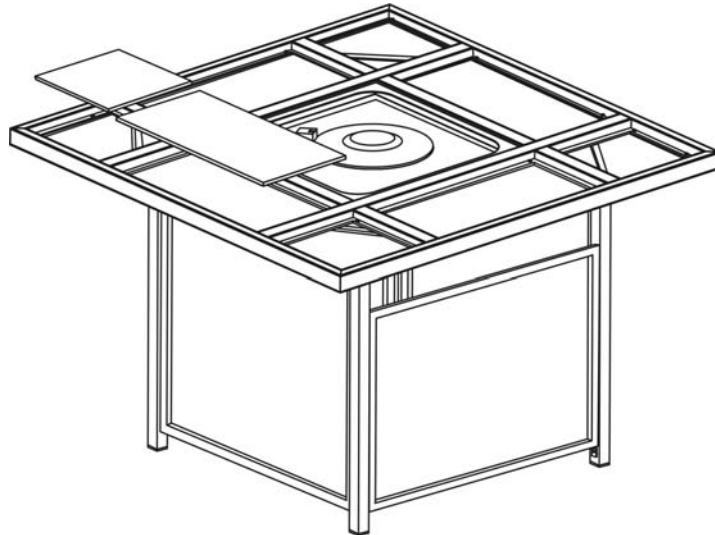
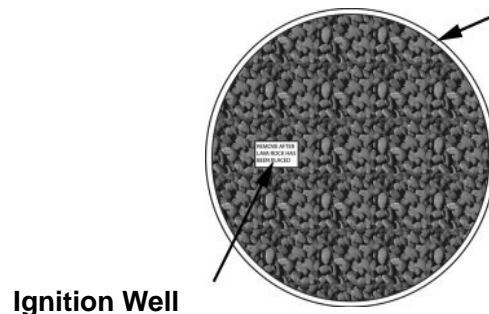

Figure 11

12. Pour the lava rocks into the burner completely covering the burner. See Figure 12



Ignition Well

Figure 12

13. Remove the cardboard cover from the ignition well as shown in Figure 13. Remove any lava rock or fire ice on top of ignition well.

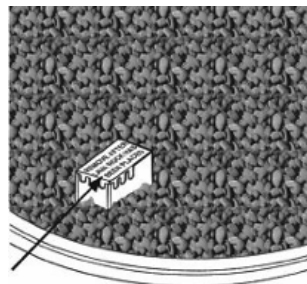

Cardboard Cover

Figure 13

14. Open the tank valve. Apply a solution of soapy water to the tank-regulator connection and to the valve-hose connection to check for leaks as shown in Figure 14. If soap bubbles continue to form, the connection has a leak. If a leak is found, close the tank valve and tighten all connections.

NOTE: NEVER USE A FLAME TO CHECK FOR LEAKS.

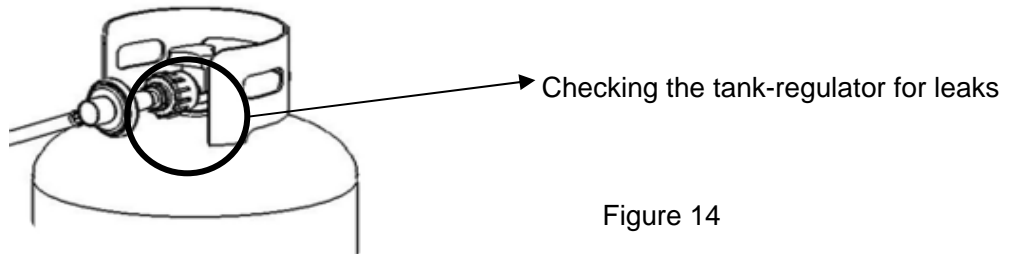

Figure 14

BATTERIES

Make sure the control knob is in the "OFF" position. Unscrew the push button cap on the ignition module located on the control panel to access the battery compartment. The ignition module requires one Alkaline AAA size battery (1.5V). The negative (-) end goes in first. See Figure 15. Dispose of battery safely. May explode or leak if charged or disposed of in fire. Make sure of the polarity. Mercury and cadmium free.

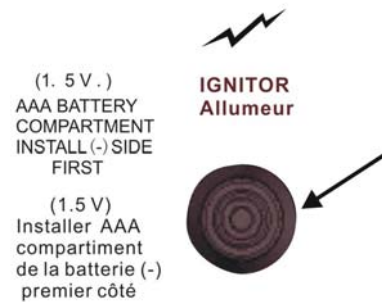
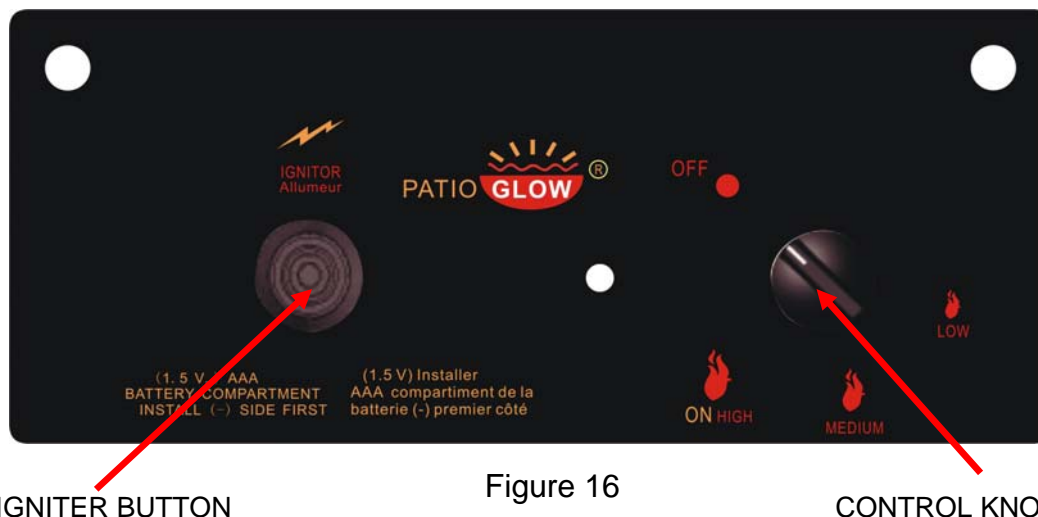

Figure 15

LIGHTING INSTRUCTIONS

Warning: If these instructions are not followed exactly, a fire or explosion may result in causing property damage, personal injury or loss of life.

1. Make sure the control knob is in the "OFF" position. See Figure 16 Open the tank valve all the way.



2. Push in the igniter button. You will hear a slight clicking sound. With the igniter button pushed in, push and turn the control knob to the "ON" position. The fire should light within a few seconds. Once the flame is lit, release the igniter button and continue to hold the control knob in for 10 to 15 seconds. Release the control knob. The control knob should pop back out and then remain lit.

Note: If the fire does not light, turn the knob to the "OFF" position and wait five (5) minutes before trying again.

3. To turn down the flame, push the control knob in slightly and turn to Medium (medium or Low (small flame)).

4. To shut down the fire pit, turn the control knob to the "OFF" position and turn off the tank valve.

MAINTENANCE

The flames should look like those in Figure 17 To clean the burner, use a soft brush after the burner has cooled completely. Never use a vacuum cleaner on the burner. It is recommended that the fire pit be stored indoors during the winter if it will be subjected to freezing temperatures. The LP cylinder must be disconnected and removed from the appliance before the appliance can be stored indoors.



Figure 17

TROUBLESHOOTING GUIDE

PROBLEM	CAUSE	REMEDY
Burner won't light	No Propane Gas at Burner	Check that gas tank valve is open. Turn control knob to "ON" and push control knob in. Make sure tank has propane gas.
	No Spark at Electrode	Check that AAA battery is installed with negative (-) end first and has a charge. Check that the wire is connected to the ignition module. Check that the electrode is not cracked or broken.
	Lack of oxygen	Remove excess lava rocks or fire ices from around the ignition well.
Burner won't stay lit after lighting	Thermocouple not in flame	Check that the tip of the thermocouple is even with the top of the ignition well. Remove any lava rocks from the ignition well.
	Thermocouple connection at the main control valve is loose	Tighten the thermocouple nut at the back of the valve.
	No Lava Rocks on Burner	Cover the burner with lava rocks per the instructions

90 DAYS LIMITED WARRANTY

What is Covered Under This Warranty?

The item you have purchased is warranted against defects in materials and workmanship for the following parts as outlined below only when unit is installed and operated in accordance with the instructions in this Owner's Manual and in compliance with local building and fire codes:

- Burner Assembly
- Firepit Base
- Firepit Top

How Do I Obtain Warranty Service?

To obtain warranty service, you must contact our customer service center within the relevant warranty period and provide us with a copy of your dated register receipt as proof of the purchase date. We reserve the right to request photographs and/or return of the defective item(s) and/or such other evidence relating to any claim as we shall reasonably require. Please call our customer service center at 1-800-416-3511 for additional warranty claim details and procedures.

What are the Limitations and Exclusions of this Warranty?

Warranty Limitations:

This warranty is subject to the limitation set forth above. In addition, this warranty is made to the original purchaser only and is effective only if items are purchased from one of our authorized dealers. This warranty is not transferable. For warranty replacements based on warranty claims submitted within ninety (90) days of purchase, we will not be responsible for charges associated with shipments outside continental North America at any time or for any reason.

Warranty Exclusions: This warranty is subjected to the exclusions set forth above. In addition, the following are excluded from coverage under this warranty: any item used for commercial, contract or any other non-residential purpose; clearance items, display models or items purchased "as is"; freight damage; items subject to misuse, abuse, neglect or lack of proper care or maintenance (including without limitation as provided in any "care and maintenance guide" or similar information we provide); normal wear and tear; damage caused by acts of nature, acts of force majeure, vandalism, fire or other causality, or improper assembly; hardware against corrosion or rusting; purchased or replacement parts; and all plastic parts. Also excluded are loss of use or time; inconvenience; money; travel; packaging; or incidental, special or consequential damages of any kind. Replacement of defective items or parts as provided herein shall constitute your sole and exclusive remedy for items which are not as warranted. In no event shall our responsibility exceed the purchase price of the item found to be other than as warranted. This warranty is the exclusive statement of your rights with respect to items you have purchased and supersedes any other express warranty or statement, written or oral, made in connection with the purchase and sale of such items. The term "item" when used herein in the singular refers to the specific piece found to be defective, and not to the entire set of which the item is a part.

Some states do not allow exclusion or limitation of incidental or consequential damage, so that limitation may not apply to you. This warranty gives you specific legal rights, and you may also have other rights that vary from state to state

**IMPORTANT!! PLEASE READ ENTIRE INSTRUCTION SHEET BEFORE ASSEMBLY!!
TO EXPEDITE ANY FUTURE WARRANTY CLAIMS, PLEASE KEEP INSTRUCTION SHEET, WARRANTY CARD AND RECEIPT**

Step 1: Identify all parts packed in the carton against the parts list. Remove all protective materials. Place parts on a non-abrasive surface to avoid scratching. If you are missing any parts or are unsure how to proceed with the assembly, call our Customer Service Center at 1-800-416-3511. **Do not attempt assembly if any parts are missing or damaged.**

Step 2: Attach the leg support to the chair legs (B1 & B2) by using the 1/4"x20 mm bolts and washers as shown in Fig.1. Guide these bolts through the holes in the leg support, into pre-drilled holes in the chair legs. **Hand tighten only.**

Step 3: Attach the support bar to the chair legs by using the 1/4"x20 mm bolts and washers as shown in Fig.2. Guide these bolts through the holes in the support bar, into the pre-drilled holes in the chair legs. **Hand tighten only.**

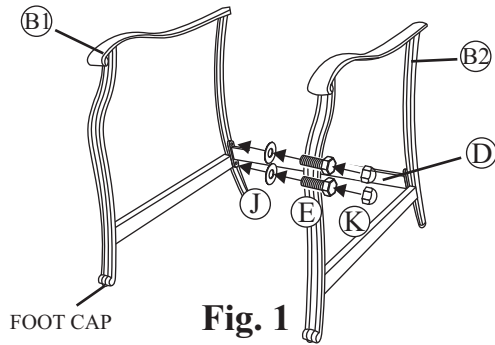

Fig. 1

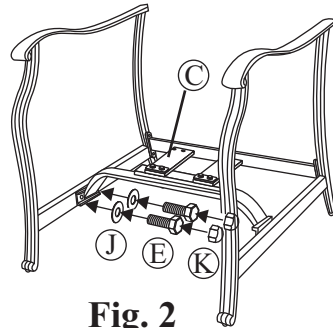

Fig. 2

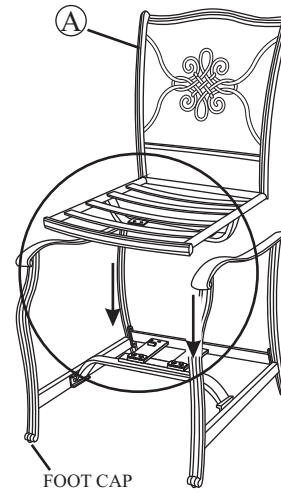

Fig. 3

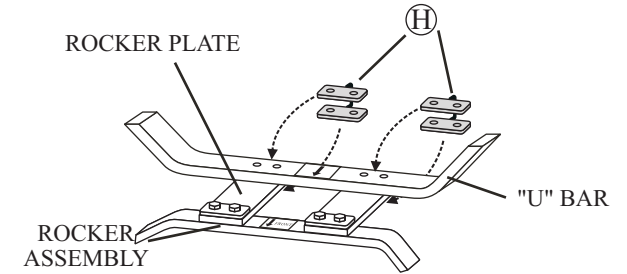

Fig. 4

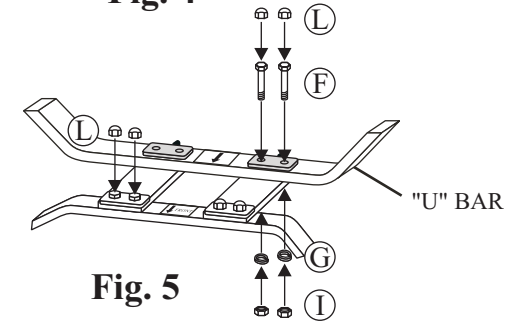

Fig. 5

NOTE: MAKE SURE ARROWS FROM BOTH THE "U" BAR AND ROCKER ASSEMBLY ARE POINTING IN THE SAME DIRECTION!

SEAT DESIGNS MAY VARY BUT THE ASSEMBLY IS THE SAME

Step 4: At this time make any adjustments to alignment of all parts. Tighten all bolts a few revolutions at a time, alternating between bolts until tightened. **Do not over tighten. Over tightening may strip bolts.**

Step 5: Set the chair frame on the rocker assembly with front of the seat facing you and the arrows on the "U" bar pointing towards you as shown in Fig.3. This is very important for a safe, balanced rocking motion. **If chair frame has been properly positioned on the rocker assembly, all arrows on the "U" bar and rocker assembly will be pointing in the same direction.**

Step 6: Critical Step: The "U" metal plates must be installed in the proper location. Read this step and carefully examine. Adjust alignment of the holes of support bar and "U" bar. Insert a "U" metal plate as shown in Fig.4. Then guide the 5/16"x40 mm bolts through the holes in the "U" metal plate, "U" bar, rocker plate, and bottom portion of the "U" metal plate. Add a Ø8.0 x 2.3 mm spring washer and a nut to each bolt as shown in Fig.5. **Hand tighten only.** Repeat the same procedure on the other side.

CAUTION: Failure to place "U" metal plates under the rocker plates and above the "U" bar exactly as shown in diagram will cause the bolt heads and nuts to damage the structure of the rocker plates and the "U" bar. Damage due to over tightening of bolts or improper assembly could cause injury and may void your warranty.

Step 7: Tighten all nuts and bolts with the hex wrenches provided. **Do not over tighten.** Remove arrow labels from "U" bar and rocker assembly. Cover all bolts with bolt covers.

Step 8: Your chair is ready for use. If you need any assistance, please call our Customer Service Center at 1-800-416-3511.

IMPORTANT NOTE: Damage to welds or frames resulting from over tightened bolts or improper assembly is not covered under our warranty. Please read all instructions carefully before assembly. If you have any questions regarding your assembly, call our Customer Service Center at 1-800-416-3511.

** NOTE: PARTS SHOWN ON PARTS LIST ARE NOT TO SCALE*

PARTS LIST	DESCRIPTION	ORDER PART #	QTY
A	CHAIR FRAME		1
B1	LEFT LEG		1
B2	RIGHT LEG		1
C	SUPPORT BAR		1
D	LEG SUPPORT		1
E	1/4" X 20 MM BOLT	HW0465	8
F	5/16" X 40 MM BOLT	HW0295	4
G	Ø8.0 X 2.3 MM SPRING WASHER	HW0003	4
H	"U" METAL PLATE	HW0618	4
I	5/16" NUT	HW0015	4
J	Ø6.5 X 1.0 MM WASHER	HW0004	8
K	BOLT COVER-1	HW0442	8

PARTS LIST	DESCRIPTION	ORDER PART #	QTY
L	BOLT COVER-2	HW0028	8
M	HEX WRENCH-1	HW0009	1
N	HEX WRENCH-2	HW0007	1
	ROCKER PLATE FACTORY ASSEMBLY	G0314	
	FOOT CAP FACTORY ASSEMBLY	FC0030	

CARE AND MAINTENANCE

FRAMES

Cleaning - Use mild soap and warm water. Do not use abrasive materials, cleansers or bleach products. Rinse with clean water and dry thoroughly.

Maintenance - Periodically clean and dry thoroughly. Be sure to drain any water accumulated inside the frames. To thoroughly drain frames, remove foot caps and tilt the frames, if necessary, to remove all water. This is critical. Water allowed to accumulate inside the frames and then exposed to sub-freezing temperatures can cause damage to the frame tubing. Such damage is not covered under warranty. Always clean, drain and dry thoroughly before storing for the winter. For best results, always store or cover your furniture when not in use. We recommend commercially available outdoor furniture covers. Any small nicks or scratches can be covered with a light application of touch-up paint.

** When cleaning or moving large or heavy items, always have two people work together. Never drag furniture.

FABRICS (CUSHIONS/SLINGS)

Cleaning - Wipe minor spills immediately. Clean with mild soap, warm clean water and soft cloth. Do not use abrasive materials, cleansers or bleach products. Although fabric has been treated to resist stains, occasional use of commercially available fabric cleaners may be necessary. Follow manufacturer's instructions.

Maintenance - The best way to maintain the beauty of cushions and slings is to store them in a dry area and out of the elements when not in use or cover with commercially available outdoor furniture covers.

STRAPS

Cleaning - Wash frequently with mild soap, warm water and a soft cloth. Rinse thoroughly with warm, clean water. Do not use abrasive materials, cleansers or bleach products.

Maintenance - Periodic application of commercially available vinyl cleaners and vinyl protectors will enhance the look and prolong the life of straps. If your strap chair has cushions, make sure any vinyl protectors applied are completely dry before placing cushion back on the chair.

LIMITED WARRANTY

- **Frames.** Frame construction is warranted against defects in material and workmanship for seven years from purchase date. Damage to frames or welds resulting from improper assembly or exposure to water and/or sub-freezing temperatures is not covered.
- **Finishes.** Paint finishes are warranted against peeling, cracking and blistering for one year from purchase date provided the unit has not been scratched or abraded. Chips and scratches resulting from normal wear and tear are not covered.
- **Fabrics.** Fabrics and cushions (if applicable) are warranted against separation at the seams for one year from date of purchase. Fabric is warranted against loss of dimensional stability from exposure to elements for five years; Fading and/or discoloration resulting from exposure to elements, oils, spills, fluids, chemicals, or any other cause are not covered.
- **Straps and/or wicker.** Straps and/or wicker weave (if applicable) are warranted against separation and tearing for one year from purchase date. Fading and/or discoloration resulting from exposure to the elements, oils, spills, fluids, chemicals, or any other cause is not covered.
- **Umbrellas.** Umbrellas (if applicable) are warranted against defects in material and workmanship only for one year from purchase date. Umbrella bases (if applicable) are not covered under any circumstance.
- **Table tops.** Natural stone tabletops only are warranted against defects in materials or workmanship only for one year from purchase date. All other table tops (including without limitation glass and faux stone) are not covered under any circumstances.

Warranty limitations: This warranty is subject to the limitations set forth above. In addition, this warranty is made to the original purchaser only, and is effective only when item(s) is purchased from one of our authorized dealers. This warranty is not transferable. For warranty replacements based on warranty claims submitted within the first year of purchase, we will pay shipping and handling charges within the continental North America. After the first year, shipping and handling charges are your responsibility. We will not be responsible for charges associated with shipments outside the continental North America at any time or for any reason.

Warranty exclusions: This warranty is subject to the exclusions as set forth above. In addition, the following are excluded from coverage under this warranty: any item used for commercial, contract or any other non-residential purpose; clearance items, display models or items purchased "as is"; freight damage; items subject to misuse, abuse, neglect or lack of proper care and maintenance (including without limitation as provided in any "care and maintenance guide"); normal wear and tear; damage caused by acts of nature, acts of force majeure, vandalism, fire or other casualty, or improper assembly; hardware against corrosion or rusting; purchased or replacement parts; and all plastic parts. Also excluded are loss of use or time; inconvenience; money; travel; packaging; or incidental, special or consequential damages of any kind. Replacement of defective items as provided herein shall constitute your sole and exclusive remedy for items which are not as warranted. In no event shall our responsibility exceed the purchase price of the items found to be other than as warranted. This warranty is the exclusive statement of your rights with respect to the defects in the items you have purchased and supersedes any other express warranty or statement, written or oral, made in connection with the purchase and sale of such items. When used herein, the term "item" when used in the singular, refers to the specific item found to be defective, and not to the entire set of which the item is a part.

Some states do not allow exclusion or limitation of incidental or consequential damages, so that limitation above may not apply to you. This warranty gives you specific legal rights, and you may also have other rights which vary from state to state.



AGIO INTERNATIONAL COMPANY LTD.

SHUNDE SHIAN FURNITURE INDUSTRIES CO. LTD.

PATIO FURNITURE & ACCESSORIES ASSEMBLY INSTRUCTIONS



STOP - IMPORTANT

If you have any problems with this product (missing or damaged parts, assembly issues), please

DO NOT RETURN TO THE RETAILER/STORE

where you purchased the product. Call our Customer Service Hotline at:

1-800-416-3511

Between 9:00 AM and 5:00 PM Eastern Time, Monday through Friday

Or visit our website at: www.agio-usa.com

To expedite any future warranty claims, retain the instruction sheet, warranty card, and receipt for future use. you are encouraged to register your purchase on our website at www.agio-usa.com

For additional online video support on assembly, troubleshooting, and care and maintenance of your outdoor furniture, please visit our website at: www.agio-usa.com/support