



Gas Fired Residential Combi Boiler

Floor Mount



INSTALLATION / START-UP

MAINTENANCE / PARTS

WARRANTY

Models
WBRCNG140F
WBRCLP140F



Heat Exchanger Bears the ASME "H" Stamp

NOTICE: Westinghouse reserves the right to make product changes or updates without notice and will not be held liable for typographical errors in literature.

NOTE TO CONSUMER: PLEASE KEEP ALL INSTRUCTIONS FOR FUTURE REFERENCE.

The surfaces of these products contacted by consumable water contain less than 0.25% lead by weight, as required by the Safe Drinking Water Act, Section 1417.

⚠ WARNING

IF THE INFORMATION IN THIS MANUAL IS NOT FOLLOWED EXACTLY, A FIRE OR EXPLOSION MAY RESULT, CAUSING PROPERTY DAMAGE, PERSONAL INJURY, OR LOSS OF LIFE. DO NOT STORE GASOLINE OR OTHER FLAMMABLE VAPORS AND LIQUIDS IN THE VICINITY OF THIS OR ANY OTHER APPLIANCE.

WHAT TO DO IF YOU SMELL GAS

- Do not try to light any appliance.
- Do not touch any electrical switch.
- Do not use any phone in your building.
- Immediately call your gas supplier from a neighbor's phone. Follow the gas supplier's instructions.
- If you cannot reach your gas supplier, call the fire department. Installation and service must be provided by a qualified installer, service agency, or the gas supplier.

FOR YOUR SAFETY READ BEFORE OPERATING

WARNING: If you do not follow these instructions exactly, a fire or explosion may result, causing property damage, personal injury or loss of life.

- A. This appliance does not have a pilot. It is equipped with an ignition device which automatically lights the burner. Do not try to light the burner by hand.
- B. BEFORE OPERATING smell all around the appliance area for gas. Be sure to smell next to the floor because some gas is heavier than air and will settle on the floor.
- WHAT TO DO IF YOU SMELL GAS
- Do not try to light any appliance
 - Do not touch any electric switch; do not use any phone in your building
 - Immediately call your gas supplier from a neighbor's phone. Follow the gas suppliers' instructions.
- If you cannot reach your gas supplier, call the fire department.
- C. Use only your hand to turn the gas control knob. Never use tools. If the handle will not turn by hand, don't try to repair it, call a qualified service technician. Force or attempted repair may result in a fire or explosion.
- D. Do not use this appliance if any part has been under water. Immediately call a qualified service technician to inspect the appliance and to replace any part of the control system and any gas control which has been under water.

OPERATING INSTRUCTIONS

1. STOP! Read the safety information above.
2. Set the thermostat to lowest setting.
3. Turn off all electric power to the appliance.
4. This appliance is equipped with an ignition device which automatically lights the burner. Do not try to light the burner by hand.
5. Remove front cover.
6. Turn gas shutoff valve to "off". Handle will be across the piping, do not force.
7. Wait five (5) minutes to clear out any gas. If you then smell gas, STOP! Follow "B" in the safety information above on this label. If you don't smell gas, go to next step.
8. Turn gas shutoff valve to "on". Handle will be in line with piping.
9. Install Front Cover.
10. Turn on all electric power to appliance.
11. Set thermostat to desired setting.
12. If the appliance will not operate, follow the instructions "To Turn Off Gas To Appliance" and call your service technician or gas supplier.

GAS VALVE
ON

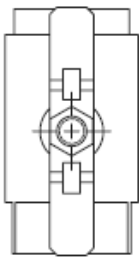

GAS VALVE
OFF

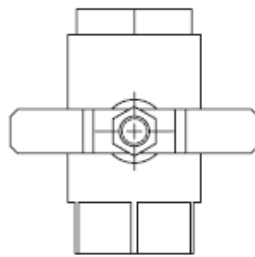

TO TURN OFF GAS TO APPLIANCE

1. Set the thermostat to lowest setting.
2. Turn off all electric power to the appliance if service is to be performed.
3. Remove Front Cover.
4. Turn gas shutoff valve to "off". Handle will be across the piping. Do not force.
5. Install Front Cover.

LP-175 Rev. 4 3-11-08

SPECIAL ATTENTION BOXES

The following defined terms are used throughout this manual to bring attention to the presence of hazards of various risk levels, or to important product information.

⚠ DANGER

DANGER indicates an imminently hazardous situation which, if not avoided, will result in death or serious injury.

⚠ WARNING

WARNING indicates a potentially hazardous situation which, if not avoided, could result in death or serious injury.

⚠ CAUTION

CAUTION indicates a potentially hazardous situation which, if not avoided, may result in minor or moderate injury.

CAUTION

CAUTION used without the safety alert symbol indicates a potentially hazardous situation which, if not avoided, may result in property damage.



NOTICE

NOTICE is used to address practices not related to personal injury.

SAFETY INSTRUCTIONS

SAFETY INSTRUCTIONS (or equivalent) signs indicate specific safety related instructions or procedures.

NOTE: Contains additional information important to a procedure.

| | |
|---|---|
| <div style="text-align: center; background-color: black; color: white; padding: 5px;">⚠ DANGER</div>  <p>⚠ Vapors from flammable liquids will explode and catch fire causing death or severe burns. Do not use or store flammable products such as gasoline, solvents or adhesives in the same room or area near the water heater. Keep flammable products: 1. far away from heater, 2. in approved containers, 3. tightly closed and 4. out of children's reach.</p> <p>Water heater has a main burner and pilot flame. The pilot flame: 1. which can come on at any time and 2. will ignite flammable vapors. Vapors: 1. cannot be seen, 2. are heavier than air, 3. go a long way on the floor and 4. can be carried from other rooms to the pilot flame by air currents.</p> <p>Installation: Do not install water heater where flammable products will be stored or used unless the main burner and pilot flames are at least 18" above the floor. This will reduce, but not eliminate, the risk of vapors being ignited by the main burner or pilot flame.</p> <p>Read and follow water heater warnings and instructions. If owners manual is missing, contact the retailer or manufacturer.</p> | <div style="text-align: center; background-color: black; color: white; padding: 5px;">⚠ DANGER</div>  <p>Water temperature over 125°F can cause severe burns instantly or death from scalds. Children, disabled and elderly are at highest risk of being scalded.</p> <p>See instruction manual before setting temperature at water heater.</p> <p>Feel water before bathing or showering.</p> <p>Temperature limiting valves are available, see manual.</p> |
|---|---|

FOREWORD

This manual is intended to be used in conjunction with other literature provided with the appliance. This includes all related control information. It is important that this manual, all other documents included with this system, and additional publications including the National Fuel Gas Code, ANSI Z223.1-2002, be reviewed in their entirety before beginning any work.

Installation should be made in accordance with the regulations of the Authority Having Jurisdiction, local code authorities, and utility companies which pertain to this type of water heating equipment.

Authority Having Jurisdiction (AHJ) – The Authority Having Jurisdiction may be a federal, state, local government, or individual such as a fire chief, fire marshal, chief of a fire prevention bureau, labor department or health department, building official or electrical inspector, or *others having statutory authority*. In some circumstances, the property owner or his/her agent assumes the role, and at government installations, the commanding officer or departmental official may be the AHJ.

NOTE: Westinghouse reserves the right to modify product technical specifications and components without prior notice.

FOR THE INSTALLER

DANGER

This manual must only be used by a qualified heating installer/service technician. Read all instructions in this manual before installing. Perform steps in the order given. Failure to comply could result in substantial property damage, severe personal injury, or death.

This appliance must be installed by qualified and licensed personnel. The installer should be guided by the instructions furnished with the appliance, and with local codes and utility company requirements. In the absence of local codes, preference should be given to the National Fuel Gas Code, ANSI Z223.1-2002.

INSTALLATIONS MUST COMPLY WITH:

Local, state, provincial, and national codes, laws, regulations and ordinances.

The latest version of the National Fuel Gas Code, ANSI Z223.1, from American Gas Association Laboratories, 8501 East Pleasant Valley Road, Cleveland, OH 44131.

In Canada – CGA No. B149 (latest version), from Canadian Gas Association Laboratories, 55 Scarsdale Road, Don Mills, Ontario, Canada M3B 2R3. Also, Canadian Electrical Code C 22.1, from Canadian Standards Association, 5060 Spectrum Way, Suite 100, Mississauga, Ontario, Canada L4W 5N6.

Code for the installation of Heat Producing Appliances (latest version), from American Insurance Association, 85 John Street, New York, NY 11038.

The latest version of the National Electrical Code, NFPA No. 70.

NOTE: The gas manifold and controls met safe lighting and other performance criteria when the appliance underwent tests specified in ANSI Z21.13 – latest edition.

WARNING

The hydronic supply and return connections of these products are for installation in closed loop systems ONLY! Use of this product in any manner other than described in this manual may result in premature product failure, substantial property damage, severe personal injury, or death. Damage or failure of this product (or the system in which it is installed) due to unauthorized use **IS NOT COVERED BY WARRANTY.**

TABLE OF CONTENTS

| | |
|--|----------|
| PART 1 – ITEMS SHIPPED WITH THE APPLIANCE | 7 |
| PART 2 – SAFETY REGULATIONS | 8 |
| A. OPERATION AND INSTALLATION WARNINGS | 8 |
| B. IMPROPER COMBUSTION | 9 |
| C. GAS..... | 10 |
| D. WHEN SERVICING THE APPLIANCE..... | 10 |

E. WATER QUALITY 10

F. FREEZE PROTECTION 10

PART 3 – TECHNICAL SPECIFICATIONS 11

PART 4 – PREPARE APPLIANCE LOCATION 13

A. UNCRATING THE APPLIANCE 13

B. BEFORE LOCATING THE APPLIANCE 14

C. LEVELING 15

D. CLEARANCES FOR SERVICE ACCESS 16

E. RESIDENTIAL GARAGE, CLOSET, AND ALCOVE INSTALLATIONS 16

F. EXHAUST VENT AND INTAKE PIPE 17

G. PREVENT COMBUSTION AIR CONTAMINATION 17

H. REMOVING A APPLIANCE FROM A COMMON VENT SYSTEM 17

PART 5 – VENTING 19

A. INTAKE PIPE AND EXHAUST VENT GUIDELINES 19

B. APPROVED VENT MATERIALS 20

C. ALLOWED COMBINED VENT LENGTHS 21

D. TIGHTENING APPLIANCE COLLAR TO EXHAUST VENT AND INTAKE PIPE 22

E. VENT TERMINATION 23

1. Horizontal Vent Terminations 23

2. Vertical Vent Termination 23

3. Direct Vent, Optional Horizontal and Vertical Concentric Vent 24

4. Screen Installation 24

PART 6 – INSTALL THE CONDENSATE DRAIN 24

PART 7 – GAS PIPING 26

A. GAS PIPE SIZING TABLES 26

1. Gas Pipe Sizing 26

2. Natural Gas Pipe Sizing 26

3. LP (Liquid Propane) Gas Pipe Sizing 27

B. GAS CONNECTION REQUIREMENTS 27

PART 8 – WATER PIPING 28

A. GENERAL PLUMBING CONNECTION GUIDELINES 28

B. DHW PIPING 29

C. CENTRAL HEATING PIPING SYSTEM WATER PIPING METHODS 30

D. CIRCULATOR SIZING 33

E. PRESSURE RELIEF VALVE 34

PART 9 – CONNECT ELECTRICAL POWER / INITIAL STARTUP 35

A. GENERAL OPERATING CONDITIONS 35

B. WIRING INFORMATION 35

C. DIP SWITCHES 36

PART 10 – OPERATING SYSTEM INSTRUCTIONS 41

A. CONTROL PANEL 41

B. LCD DISPLAY DESCRIPTIONS 41

C. START-UP SEQUENCE 41

D. CHANGING THE DHW SET-POINT 42

E. CHANGING THE TEMPERATURE INDICATOR 42

F. CHANGING THE CH SET-POINT 42

G. STORAGE MODE 43

H. STATUS DISPLAY MODE 43

I. INSTALLER MODE 44

J. ERROR MODE 46

K. ERROR TREE ANALYSIS 49

1. FLAME DETECTION..... 49

2. GAS DETECTION 49

3. APS / BURNER OVERHEAT LIMIT / CONDENSATE BLOCK SWITCH 50

4. STORAGE / DHW / OP / CH OVERHEAT / EXHAUST OVERHEAT SENSORS 50

L. OUTDOOR TEMPERATURE MODE (OPTIONAL)..... 50

M. 0-10 VOLT INPUT..... 51

PART 11 – START-UP PREPARATION..... 52

 A. CHECK / CONTROL WATER CHEMISTRY 52

 B. CHECK FOR GAS LEAKS 52

 C. FILL AND TEST WATER SYSTEM 53

 D. PURGE AIR FROM CH AND INTERNAL STORAGE TANK 54

 E. PURGE AIR FROM DHW SYSTEM 54

 F. CHECK THERMOSTAT CIRCUIT(S) 54

 G. CONDENSATE REMOVAL 55

 H. FINAL CHECKS BEFORE STARTING APPLIANCE 55

 I. ADJUSTING GAS PRESSURE AT THE APPLIANCE 55

 J. SETTING AND VERIFYING THE COMBUSTION SETTING 56

PART 12 –INSTALLATION AND START-UP CHECKLIST 57

PART 13 – TROUBLESHOOTING 58

PART 14 – ANNUAL MAINTENANCE PROCEDURES 59

REPLACEMENT PARTS 64







Limited Warranty for Combination Appliances 67

MAINTENANCE REPORT 69

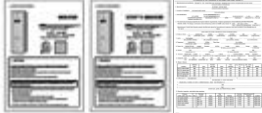
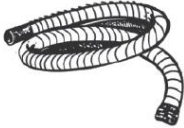
MAINTENANCE NOTES 72

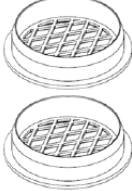
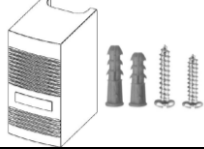
CUSTOMER INSTALLATION RECORD FORM 73

PART 1 – ITEMS SHIPPED WITH THE APPLIANCE

| ITEM | DESCRIPTION | QUANTITY |
|---|--|-----------|
| Residential Floor Mount Combi Boiler |  | 1 |
| Installation and User's Information Manuals, H2 Document |  | 1 Each |
| Condensate Hose |  | 1 |
| Condensate Adapters and Instruction Sheet |  | 1 kit |
| CH Pressure Relief Valve With 3/4" X 1" Bushing (CH Line 3/4" 30 psi) |  | 1 Each. |
| Vent Screens (3") |  | 2 Screens |
| Outdoor Sensor with Screws and Anchors |  | 1 |
| 3" CPVC |  | 6" Length |
| 1/2" X 3/4" Bell Coupling for Gas Line |  | 1 |
| Spare Parts Kit (Gaskets and O-Rings) |  | 1 |
| Propane (LP) Conversion Kit | | 1 |



| OPTIONAL PARTS (Not Included) | | | |
|---|---|-----------|-------------|
| ITEM | DESCRIPTION | QUANTITY | PART NUMBER |
| Threaded 1" CH Tankless Isolation Valves |  | 2 | 7850P-089 |
| Threaded 3/4" DHW Tankless Isolation Valves |  | 2 | 7850P-090 |
| Vent Screens (2" Mesh) |  | 2 Screens | 7850P-088 |

Table 1 – Items Included with the Appliance

PART 2 – SAFETY REGULATIONS

A. OPERATION AND INSTALLATION WARNINGS

To avoid serious injury or death, read, understand, and follow all the precautions listed here.

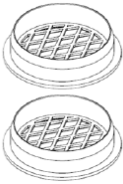
DANGER

Vapors from flammable liquids will explode and can cause a fire, resulting in personal injury or death. The appliance has a burner that can come on at any time and ignite vapors. DO NOT use or store flammable liquids around the appliance.

Improper venting can cause a build-up of carbon monoxide. Breathing carbon monoxide can result in brain damage or death. DO NOT operate the appliance unless it is properly vented to the outside and has an adequate fresh air supply for safe operation. Inspect the exterior exhaust gas outlet port and fresh air inlet port on a regular basis to ensure they are functioning properly.

A concentration of carbon monoxide as small as .04% (400 parts per million) in the air can be fatal. When making high fire or low fire adjustments, CO levels must be monitored using a flue gas analyzer such that a CO level of no more than 400 ppm is exceeded at any time during operation.

Adjusting the "low fire offset" on the gas valve in even small increments can result in a significant increase in CO concentration. To avoid serious injury or death, DO NOT make any adjustments to the gas valve without monitoring the exhaust gases with a fully functional and calibrated flue gas analyzer.

Failure to follow these statements will result in property damage, severe personal injury, or death.

WARNING

This appliance must be installed by a licensed plumber, licensed gas fitter, and/or professional service technician. Improper installation and/or operation can cause a potentially hazardous situation, which, if not avoided, could result in serious injury or death, and will void the warranty.

Westinghouse cannot anticipate every circumstance that might involve a potential hazard. Each installation has its own specialized characteristics, requirements, and possible hazards. Therefore, all possible incidents are not included in these warnings. Proper and safe installation, operation, and service are the responsibility of the professional service technician.

Proper care of the appliance is the user's responsibility. Ensure the user carefully reads and understands the User's Information Manual before operating and maintaining the appliance.

Make sure the user knows the location of the gas shut-off valve and how to operate it. Immediately close the gas shut-off valve if the appliance is subjected to fire, overheating, flood, physical damage, or any other damaging condition that might affect the operation of the unit. Have the appliance checked by a qualified technician before resuming operation.

Do not power up the unit unless the gas and water supply valves are fully opened. Make sure the fresh air intake port and exhaust gas port are open and functional.

No one but a professional service technician should attempt to install, service, or repair this appliance. There are no serviceable parts which can be changed by the user / owner. User / Owner: Contact the original professional service technician if the appliance needs repair or maintenance. If the original technician is unavailable, ask your gas supplier for a list of qualified service providers.

Keep the area around the appliance clean and free of all materials that can burn. DO NOT store or place gasoline, oils, spray paint, or other flammable products near the appliance.

WARNING

DO NOT use spray paint, hair spray, or any other flammable spray near the appliance or near the exterior fresh air intake port. DO NOT place any items in or around the exterior exhaust gas outlet port and/or fresh air inlet port that could restrict or block the flow in or out of the vent system.

DO NOT store or place newspapers, laundry, or other combustible items near the appliance or the exterior exhaust gas outlet and/or fresh air inlet port.

The owner should inspect the system monthly for damage, water stains, signs of rust, corrosion, and exhaust vent and air intake blockage. If inspection of the unit shows signs of damage, the appliance should be shut off until the problem is repaired by a qualified technician.

After installation, all appliance safety devices should be tested.

This appliance is certified for indoor installations only. The appliance consists of gas ignition system components which must be protected from water (dripping, spraying, etc.) during operation and service. Carefully consider installation location and the placement of critical components (circulators, condensate neutralizers, etc.) before installing the appliance.

DO NOT allow children to operate this unit. DO NOT use this unit if it does not appear to be operating correctly. A qualified technician should service and inspect the appliance annually.

The appliance DHW temperature is factory set to 125°F (51°C). To avoid scalding, always check the temperature of the hot water before bathing, showering, washing, etc. DO NOT adjust the water temperature while the appliance is being used by other persons.

If the appliance is exposed to the following, do not operate until all corrective steps have been made by a qualified service technician:

1. FIRE
2. DAMAGE
3. WATER

This appliance is equipped with a three prong plug. It should only be plugged directly into a properly grounded three prong receptacle. DO NOT remove the ground plug from the plug.

DO NOT alter or modify the appliance or appliance controls. This can be dangerous and WILL VOID the warranty.

Failure to follow these statements could result in property damage, severe personal injury, or death.

NOTICE

Any claims for damage or shortage in shipment must be filed immediately against the transportation company by the consignee.

This appliance provides a overheat shutdown limit. In the event the appliance water exceeds the set point of the control limit, the cutoff will trip and the appliance will shut down. Certain local codes require additional temperature limits. In addition, certain types of systems may operate at temperatures below the minimum set point of the limit provided with the appliance. Contact a qualified service technician for additional overheat controls.

NOTE: When inquiring about service or troubleshooting, reference the model and serial numbers from the appliance rating label.

WARNING

DO NOT USE THIS APPLIANCE IF ANY PART HAS BEEN SUBMERGED IN WATER. Immediately call a qualified service technician. The appliance **MUST BE** replaced if it has been submerged. Attempting to operate an appliance that has been submerged could create numerous harmful conditions, such as a potential gas leakage causing a fire and/or explosion, or the release of mold, bacteria, or other harmful particulates into the air. Operating a previously submerged appliance could result in property damage, severe personal injury, or death.

NOTE: Appliance damage due to flood or submersion is considered an Act of God, and IS NOT covered under product warranty.

WARNING

Be sure to disconnect electrical power before opening appliance cabinet or performing service. Label all wires while performing service to ensure proper re-wiring of the appliance. Wiring errors can cause improper or dangerous operation. Failure to do so could result in an electrical shock, improper appliance operation, property damage, serious personal injury, or death.

CAUTION

Due to the low water content of the appliance, improper sizing of the appliance with regard to heating system load will result in excessive cycling and accelerated component failure. Westinghouse **DOES NOT** warrant failures caused by improperly sized appliance applications. **DO NOT** oversize the appliance to the system. Modular appliance installations greatly reduce the likelihood of appliance oversizing.

B. IMPROPER COMBUSTION

WARNING

Do not obstruct the flow of combustion and ventilating air. Adequate air must be provided for safe operation. Failure to keep the exhaust vent and intake pipe clear of ice, snow, or other debris could result in property damage, serious personal injury, or death.

C. GAS

Should overheating or gas supply fail to shut off, do not turn off or disconnect electrical supply to the circulator. Instead, shut off the gas supply at a location external to the appliance.

D. WHEN SERVICING THE APPLIANCE

- To avoid electric shock, disconnect electrical supply before performing maintenance.
- To avoid severe burns, allow appliance to cool.
- Do not use petroleum-based cleaning or sealing compounds in a appliance system. Gaskets and seals in the system may be damaged, possibly resulting in substantial property damage.
- Do not use “homemade cures” or “patent medicines”. Substantial property damage, damage to appliance, and/or serious personal injury may result.
- Always verify proper operation after servicing the appliance.

E. WATER QUALITY

Potable water is defined as drinkable water supplied from utility or well water in compliance with EPA secondary maximum contaminant levels (40 CFR Part 143.3) as shown in Table 2. It is important to ensure the water quality is within these determined limits. If your water contains contaminants higher than outlined by EPA, then water treatment is recommended and additional maintenance may be required. If you suspect that your water is contaminated in any way, discontinue use of the appliance and contact an authorized technician or licensed professional.

| Contaminant | Maximum Allowable Level | Contaminant | Maximum Allowable Level |
|----------------|-----------------------------|------------------------------|-------------------------|
| Total Hardness | 200 mg/l (12 grains/gallon) | Manganese | 0.05 mg/l |
| Aluminum | 0.05 to 0.2 mg/l | pH | 6.5-8.5 |
| Chloride | 250 mg/l | Sulfate | 205 mg/l |
| Copper | 1 mg/l | Total Dissolved Solids (TDS) | 500 mg/l |
| Iron | 0.3 mg/l | Zinc | 205 mg/l |

Table 2 – Water Quality Specifications

F. FREEZE PROTECTION

CAUTION

Consider appliance piping and installation when determining appliance location.

NOTE: Damages resulting from incorrect installation or from use of products not approved by Westinghouse ARE NOT covered by warranty.

PART 3 – TECHNICAL SPECIFICATIONS

| MODEL | Residential Combi Boiler | |
|-----------------------------------|--|--|
| Installation | Indoor, Floor Stand, Fully Condensing | |
| Minimum / Maximum Input (Btu/Hr) | 28,000 / 140,000 | |
| AFUE | 92.7% | |
| Hot Water Capacity | 35°F Rise | 7.1 Gal |
| | 45°F Rise | 5.5 Gal |
| | 77°F Rise | 3.2 Gal |
| Flue System | Sealed Combustion Direct Vent | |
| Combined Vent Length | 2" (50 feet), 3" (100 feet) | |
| Shipping Weight (lbs est.) | 250 | |
| Orifice Size | NG | 0.232" (5.9 mm) |
| | LP | 0.185" (4.7 mm) |
| Gas Supply Pressure | NG | 3.5" to 14" WC |
| | LP | 3.5" to 14" WC |
| Manifold Pressure | Min (2" / 3" Vent) | NG: -0.0039" / -0.002" WC |
| | Max (2" / 3" Vent) | NG: -0.374" / -0.216" WC |
| Power Supply | Main Supply | 120V 60 Hz / 6A |
| | Maximum Power Consumption | 160W |
| Ignition System | Direct Electronic Ignition / Automatic Flame Sensing | |
| Burner System | Single Orifice Premixed Fuel Modulation Ceramic Fiber Infrared | |
| Gas Valve System | Combination Modulating (Current Proportional) | |
| Internal Pipe Material | Copper | |
| Dimensions | W 15.7" – H 53" – D 26.8" | |
| Storage Tank Water Capacity (DHW) | Under 15 Gallons | |
| Main Controller / Control Panel | GTX-920C / P-920C_CB-HTP | |
| CH Pressure | Min 15 PSI - Max 30 PSI | |
| DHW Pressure | Max 150 PSI | |
| Connection Sizes | DHW Inlet / Hot Water Outlet | ¾" NPT |
| | CH Supply / Return | 1" NPT |
| | Gas Inlet | ½" NPT (1/2" X ¾" Bell Coupling Provided to Upsize Gas Line) |
| Materials | Cabinet | Cold Rolled Carbon Steel |
| | Heat Exchanger | Primary Heat Exchanger: Stainless Steel Storage Tank: Stainless Steel |
| Safety Devices | Flame Rod, Overheat Cut Off Device, Gas Valve Operation Detector, Exhaust Temperature High Limit Sensor, Water Temperature High Limit Sensor | |

Table 3 – Technical Specifications

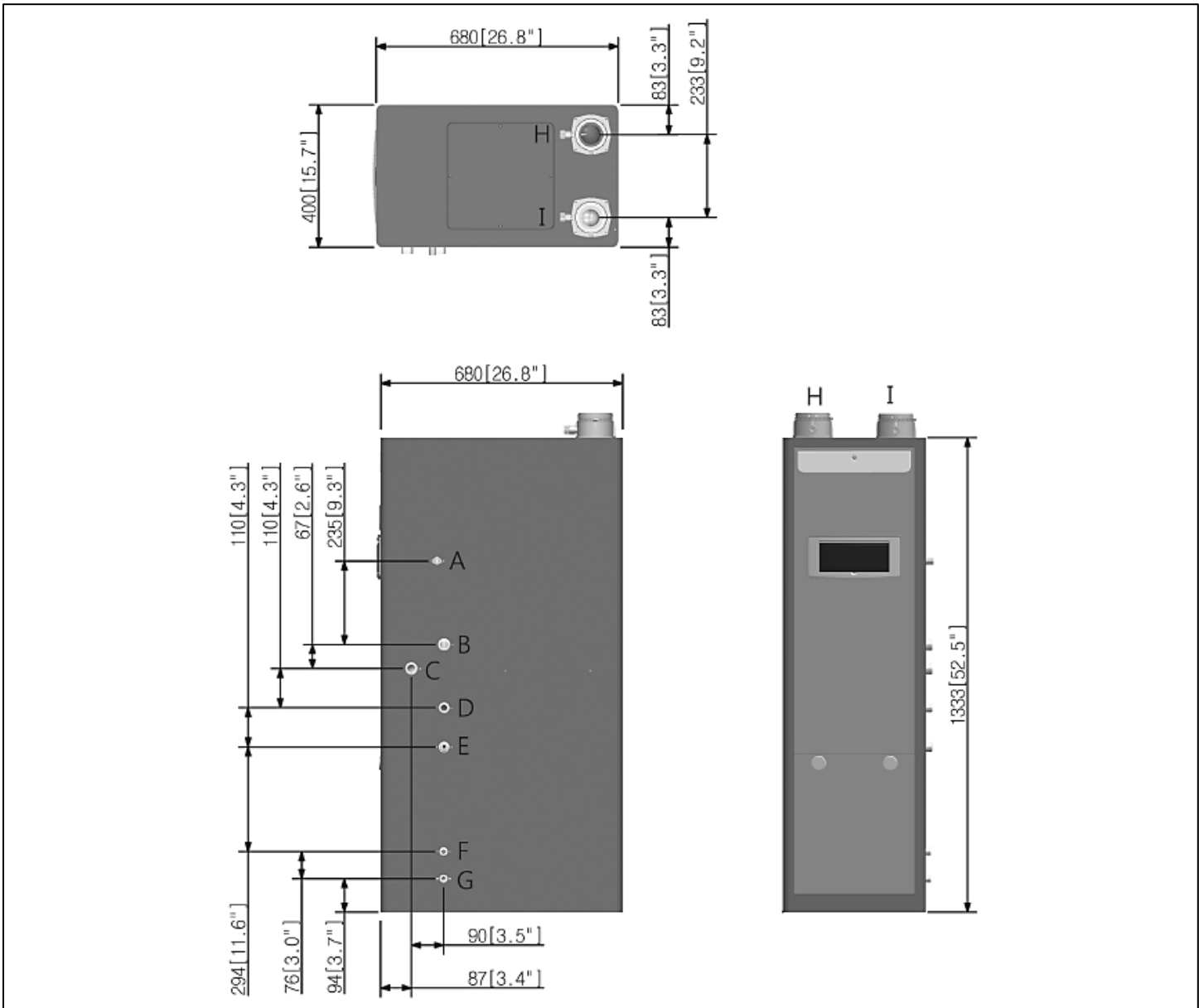

Figure 1 – Specifications and Dimensions

| | DESCRIPTION | DIAMETER (ALL NPTM) |
|---|-------------------------|--|
| A | Gas Connection Adapter | 1/2" NPT (1/2" X 3/4" Bell Coupling Provided to Upsize Gas Line) |
| B | CH Supply Adapter | 1" |
| C | CH Return Adapter | 1" |
| D | DHW Outlet Adapter | 3/4" |
| E | DHW Inlet Adapter | 3/4" |
| F | Condensate Adapter | 1/2" |
| G | Drain Adapter | 1/2" |
| H | Exhaust Vent Connection | 3" |
| I | Intake Pipe Connection | 3" |

Table 4 – Adapter Specifications

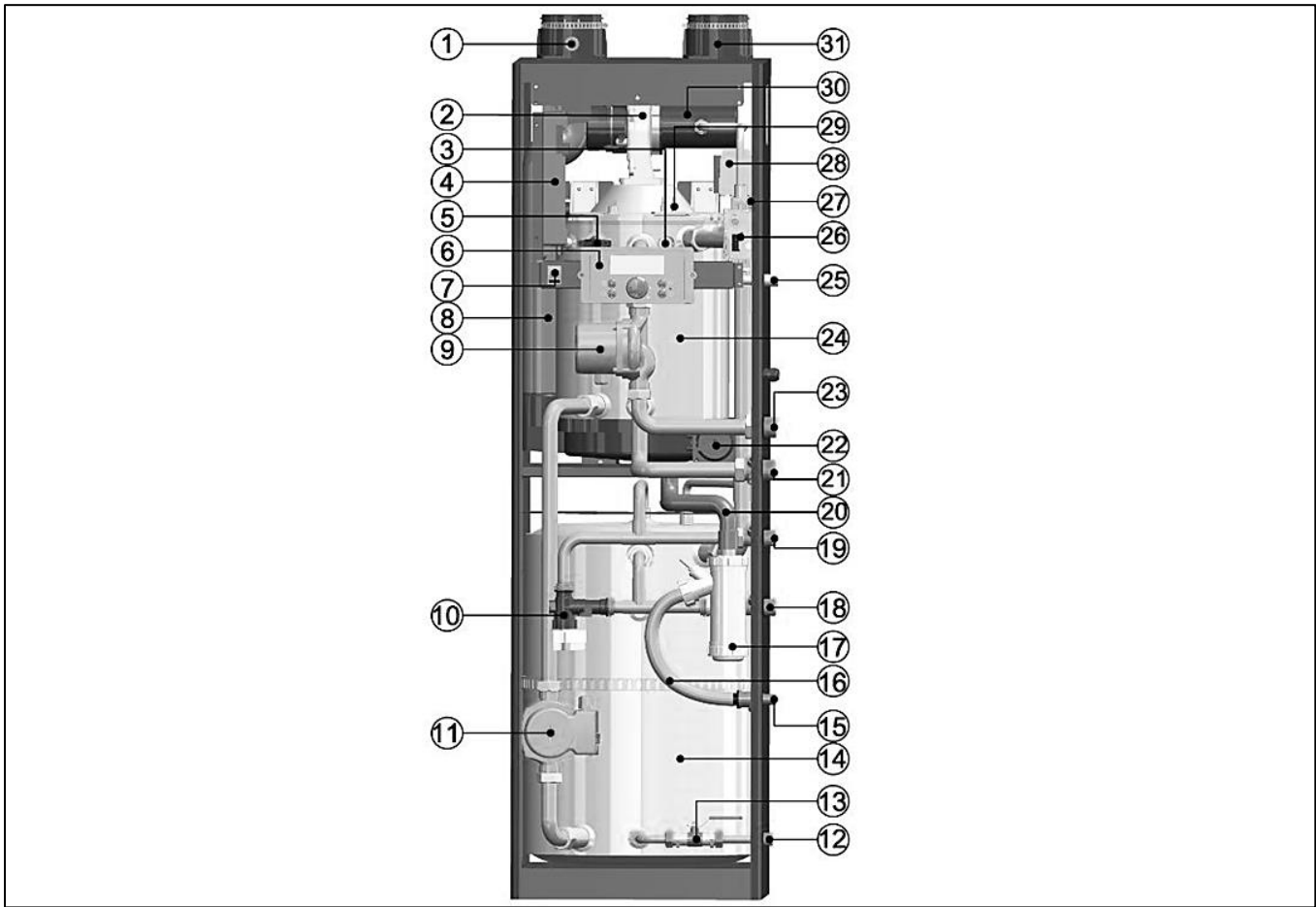

Figure 2 – Components

| NUMBER | COMPONENT DESCRIPTION | NUMBER | COMPONENT DESCRIPTION |
|--------|-----------------------------------|--------|---------------------------|
| 1 | Exhaust Vent Adapter | 17 | Condensate Trap |
| 2 | BLDC Fan | 18 | DHW Inlet Adapter |
| 3 | Flame Detection Window | 19 | DHW Outlet Adapter |
| 4 | Main PCB | 20 | Condensate Hose 2 |
| 5 | Flame Detection Sensor | 21 | CH Return Adapter |
| 6 | Control Panel | 22 | APS (Air Pressure Switch) |
| 7 | Manual ON/OFF Power Switch | 23 | CH Supply Adapter |
| 8 | Exhaust Pipe | 24 | Heat Exchanger |
| 9 | Internal CH Pump | 25 | Gas Inlet Adapter |
| 10 | Mixing Valve | 26 | Gas Valve |
| 11 | Internal Recirculation Pump (DHW) | 27 | Air Vent |
| 12 | Water Discharge Adapter | 28 | Ignition Transformer |
| 13 | Water Discharge Valve | 29 | Igniter |
| 14 | Internal Storage Tank | 30 | Air Intake Pipe |
| 15 | Condensate Trap Adapter | 31 | Air Intake Adapter |
| 16 | Condensate Hose 1 | | |

Table 5 – Component List

PART 4 – PREPARE APPLIANCE LOCATION

A. UNCRATING THE APPLIANCE

⚠ WARNING

UNCRATING APPLIANCE – Any claims for damage or shortage in shipment must be filed immediately against the transportation company by the consignee.

CAUTION

Cold weather handling – If appliance has been stored in a very cold location (below 0°F) before installation, handle with care until the plastic components come to room temperature.

Remove all sides of the shipping crate to allow the appliance to be lifted into its installation location. If surface flooring is rough, take care when sliding appliance into position, as you could damage the appliance.

CAUTION

Carefully consider installation when determining appliance location. Please read the entire manual before attempting installation. Failure to properly take factors such as appliance venting, piping, condensate removal, and wiring into account before installation could result in wasted time, money, and possible property damage and personal injury.

B. BEFORE LOCATING THE APPLIANCE**⚠ WARNING**

Incorrect ambient conditions can lead to damage to the heating system and put safe operation at risk. Ensure that the appliance installation location adheres to the information included in this manual. Failure to do so could result in property damage, serious personal injury, or death.

CAUTION

Failure of appliance or components due to incorrect operating conditions IS NOT covered by product warranty.

1. Installation Area (Mechanical Room) Operating Conditions

- Ensure ambient temperatures are higher than 32°F/0°C and lower than 104°F/40°C.
- Prevent the air from becoming contaminated by the products, places, and conditions listed in this manual.
- Avoid continuously high levels of humidity
- Never close existing ventilation openings

CAUTION

The service life of the appliance's exposed metallic surfaces, such as the casing, as well as internal surfaces, such as the heat exchanger, are directly influenced by proximity to damp and salty marine environments. In such areas, higher concentration levels of chlorides from sea spray coupled with relative humidity can lead to degradation of the heat exchanger and other appliance components. In these environments, appliances must not be installed using direct vent systems which draw outdoor air for combustion. Such appliances must be installed using room air for combustion. Indoor air will have a much lower relative humidity and, hence, potential corrosion will be minimized.

⚠ WARNING

This appliance is certified for indoor installations only. Do not install the appliance outdoors. Failure to install this appliance indoors could result in substantial property damage, severe personal injury, or death.

2. Check for nearby connections to:

- System water piping
- Venting connections
- Gas supply piping
- Electrical power
- Condensate drain

CAUTION

Locate the appliance where any leakage from the relief valve, related piping, tank, or connections will not result in damage to surrounding areas or lower floors of the building. The appliance should be located near a floor drain, or installed in an adequately drained drain pan. Westinghouse WILL NOT be held liable for leakage damages.

To conserve water and energy, insulate all water piping, especially the hot and recirculation water lines.

3. Check area around appliance. Remove any combustible materials, gasoline, and other flammable liquids.

⚠ WARNING

Failure to keep appliance area clear and free of combustible materials, liquids, and vapors can result in substantial property damage, severe personal injury, or death.

- 4. Gas control system components must be protected from dripping water during operation and service.
- 5. If the appliance is to replace an existing appliance, check for and correct any existing system problems, such as:
 - System leaks
 - Location that could cause the system and appliance to freeze and leak.
 - Incorrectly-sized expansion tank

| |
|--|
| ⚠ WARNING |
| Do not connect the appliance to any heating systems or components that have been previously used for non-potable applications. |
| Do not introduce toxic chemicals, such as antifreeze or appliance treatments, into the appliance or any piping meant for potable water purposes. |
| Ensure that all piping and components connected to the appliance are suitable for potable water applications. |
| Do not use this appliance only for space heating applications. |
| Circulators suitable for DHW applications must be used. |
| Failure to follow these instructions could result in property damage, personal injury, or death. |

6. Clean and flush system when reinstalling an appliance.

NOTE: When installing in a zero clearance location, it may not be possible to read or view some product labeling. It is recommended to make note of the appliance model and serial number.

C. LEVELING

| |
|---|
| ⚠ CAUTION |
| In order for the condensate to properly flow out of the collection system, the appliance must be installed level. Failure to ensure the appliance is installed level will result in improper appliance operation. |

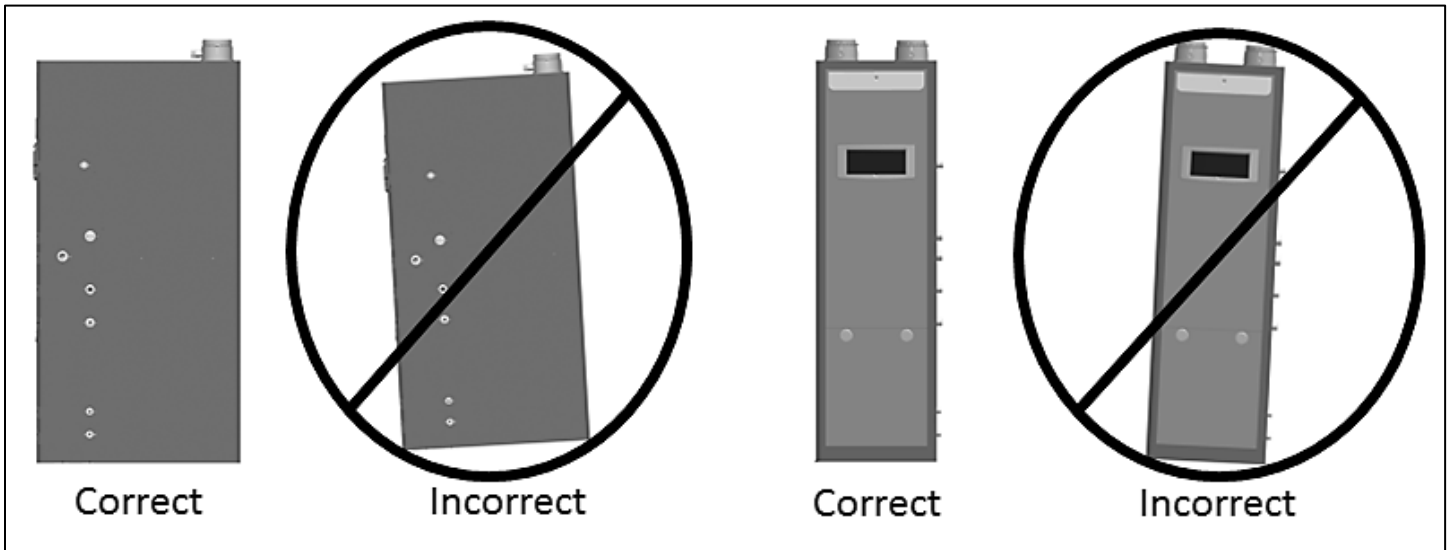

Figure 3 – Proper Leveling

D. CLEARANCES FOR SERVICE ACCESS

See Figure 4 and Table 6 for recommended service clearances. If these minimum clearances are not provided, it may not be possible to service the appliance without removing it from the space.

⚠ WARNING

Space must be provided with combustion/ventilation air openings correctly sized for all other appliances located in the same space as the appliance. The appliance cover must be securely fastened to prevent it from drawing air from the appliance room. This is particularly important if the appliance is in a room with other appliances. Failure to comply with the above could result in substantial property damage, severe personal injury, or death.

MINIMUM CLEARANCES

| Installation Clearances from Non-Combustibles / Combustibles | Recommended Service and Proper Operation Clearances |
|--|---|
| Top | 18 in. (45.7 cm) |
| Back | 0 in. (0 cm) |
| Front | 24 in. (60.9 cm) |
| Right Side | |
| Left Side | 6 in. (15.2 cm) |

Table 6 – Minimum Installation and Service Clearances

NOTE: For closet installations, a combustible door or removable panel is acceptable front clearance.

MINIMUM CLEARANCES FROM COMBUSTIBLE MATERIALS

- Hot water pipes – at least 1” from combustible materials.
- Exhaust vent pipe – at least 1” from combustible materials.

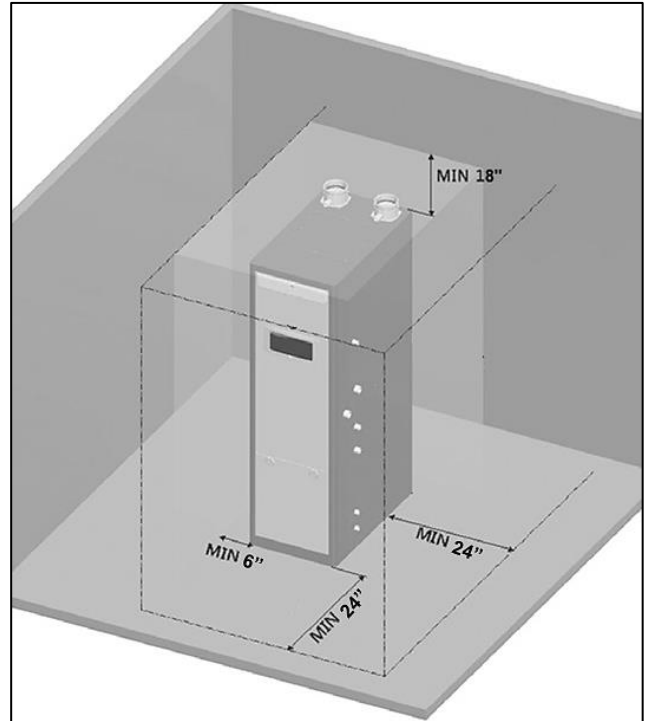

Figure 4 – Minimum Service Clearances

CAUTION

Always take future maintenance into consideration when locating the appliance. If the appliance is located in an installation location with limited clearances, it may be necessary to remove the appliance from the space to perform maintenance. Failure to consider maintenance when determining installation location could result in property damage.

E. RESIDENTIAL GARAGE, CLOSET, AND ALCOVE INSTALLATIONS

CAUTION

Check with your local Authority Having Jurisdiction for requirements when installing boiler in a garage, closet, or alcove. Please read the entire manual before attempting installation. Failure to properly take factors such as boiler venting, piping, condensate removal, and wiring into account before installation could result in wasted time, money, and possible property damage and personal injury.

PRECAUTIONS

If the boiler is located in a residential garage, it should be installed per the latest edition of the National Fuel Gas Code, ANSI Z223.1, and CGA-B149 Installation Code in Canada.

- Mount the bottom of the boiler a minimum of 18” above the floor of the garage, to ensure the burner and ignition devices are well off the floor.
- Locate or protect the boiler so it cannot be damaged by a moving vehicle.

⚠ WARNING

For closet or alcove installations, a two pipe venting system must be used. Failure to follow this warning could result in substantial property damage, severe personal injury, or death.

⚠ WARNING

The space must be provided with correctly sized combustion/ventilation air openings for all other boilers located in the space with the boiler. Do not install the boiler in an attic. Failure to comply with these warnings could result in substantial property damage, severe personal injury, or death.

F. EXHAUST VENT AND INTAKE PIPE

⚠ WARNING

Vents must be properly supported. The appliance exhaust and intake connections are not designed to carry heavy weight. Vent support brackets must be within 1' of the appliance and the balance at 4' intervals. Venting must be readily accessible for visual inspection for the first 3' from the appliance.

The appliance is rated ANSI Z21.13 Category IV (pressurized vent, likely to form condensate in the vent), and requires a special vent system designed for pressurized venting.

You must also install air intake piping from outdoors to the appliance flue adaptor. The resultant installation is categorized as direct vent (sealed combustion).

NOTE: To prevent combustion air contamination, see Table 7 in this section when considering exhaust vent and intake pipe termination.

Exhaust vent and intake pipe may be vented vertically through the roof or out a side wall. Venting methods are detailed in the Venting Section. Do not attempt installation using any other means. Be sure to locate the appliance so exhaust vent and intake piping can be routed through the building and properly terminated. Exhaust vent and intake piping lengths, routing, and termination method must comply with methods and limits given in the venting section.

G. PREVENT COMBUSTION AIR CONTAMINATION

Install intake piping for the appliance as described in the Venting section. Do not terminate exhaust in locations that can allow contamination of intake air.

⚠ WARNING

Ensure that the intake air will not contain any of the contaminants below. For example, do not pipe intake near a swimming pool. Avoid areas subject to exhaust fumes from laundry facilities. These areas always contain contaminants. Contaminated air will damage the appliance, resulting in possible substantial property damage, severe personal injury, or death.

| PRODUCTS TO AVOID | AREAS LIKELY TO HAVE CONTAMINANTS |
|---|--|
| Spray cans containing fluorocarbons | Dry cleaning/laundry areas and establishments |
| Permanent wave solutions | Swimming pools |
| Chlorinated waxes/cleaners | Metal fabrication plants |
| Chlorine-based swimming pool chemicals | Beauty shops |
| Calcium chloride used for thawing | Refrigeration repair shops |
| Sodium chloride used for water softening | Photo processing plants |
| Refrigerant leaks | Auto body shops |
| Paint or varnish removers | Plastic manufacturing plants |
| Hydrochloric or Muriatic acid | Furniture refinishing areas and establishments |
| Cements and glues | New building construction |
| Antistatic fabric softeners used in clothes dryers | Remodeling areas |
| Chlorine-type bleaches, laundry detergents, and cleaning solvents | Garages and workshops |
| Adhesives used to fasten building products | |

Table 7

NOTE: DAMAGE TO THE APPLIANCE CAUSED BY EXPOSURE TO CORROSIVE VAPORS IS NOT COVERED BY WARRANTY.
(Refer to the limited warranty for complete terms and conditions).

H. REMOVING A APPLIANCE FROM A COMMON VENT SYSTEM

⚠ DANGER

Do not install the appliance into a common vent with any other appliance. This will cause flue gas spillage or appliance malfunction, resulting in possible substantial property damage, severe personal injury, or death.

⚠ DANGER

Failure to follow all instructions can result in flue gas spillage and carbon monoxide emissions, causing severe personal injury or death.

When removing an existing appliance, the following steps must be followed.

1. Seal any unused openings in the common venting system.
2. Visually inspect the venting system for proper size and horizontal pitch to determine if there is blockage, leakage, corrosion or other deficiencies that could cause an unsafe condition.
3. If practical, close all building doors, windows and all doors between the common venting system and other spaces in the building. Turn on clothes dryers and any appliances not connected to the common venting system. Turn on any exhaust fans, such as range hoods and bathroom exhausts, at maximum speed. Do not operate a summer exhaust fan. Close all fireplace dampers.
4. Place in operation the appliance being inspected. Follow the lighting instructions. Adjust the thermostat so the appliance will operate continuously.
5. Test for spillage at the draft hood relief opening after 5 minutes of main burner operation. Use the flame of a match or candle or smoke from a cigarette.
6. After it has been determined that each appliance remaining connected to common venting system properly vents when tested as outlined, return doors, windows, exhaust fans, fireplace dampers and any other gas burning appliance to their previous condition of use.
7. Any improper operation of the common venting system should be corrected so the installation conforms to the National Fuel Gas Code, ANSI Z223.1. When resizing any portion of the common venting system, the common venting system should be resized to approach the minimum size as determined using the appropriate tables in Appendix G in the National Fuel Gas Code, ANSI Z 223.1.

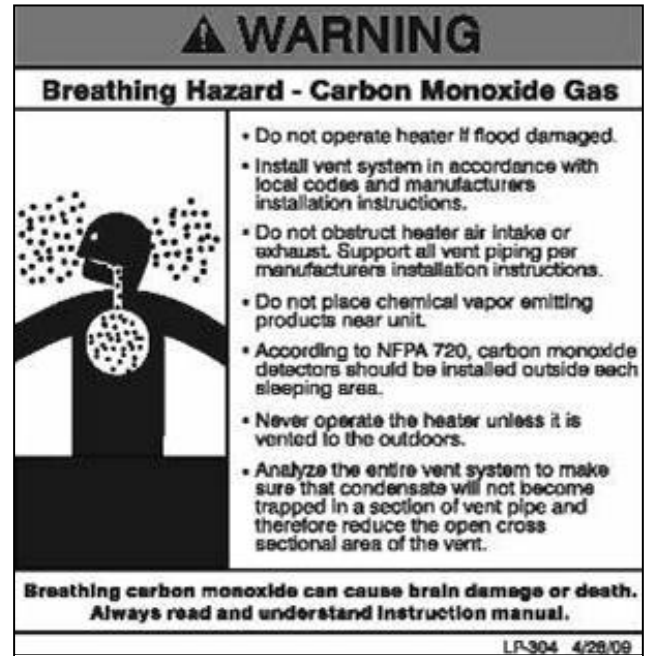

Figure 5 - CO Warning Label

PART 5 – VENTING

DANGER

Vent this appliance in accordance with these instructions. Failure to do so will result in property damage, severe personal injury, or death.

WARNING

DO NOT mix vent systems or materials unless specifically told to do so in this manual.

DO NOT thermally insulate the exhaust vent or intake pipes.

DO NOT use an electric damper, vent damper, or draft hood with this appliance.

DO NOT locate the exhaust vent or intake pipe terminations where exposed to prevailing winds.

Moisture will be produced by the exhaust vent. Take precautions when determining exhaust vent termination. Moisture may fall from the vent termination to the ground and turn to ice in freezing conditions. Moisture or ice can produce a hazardous condition.

Exhaust condensate is acidic, and could deteriorate the surface below the exhaust vent termination. Ensure this surface is in good repair (sealed, painted, etc.) to prevent deterioration.

Pitch the exhaust vent pipe ¼" back to the appliance. This ensures that condensate in the exhaust vent returns to the appliance and drains properly.

For closet and alcove installations: CPVC, polypropylene, or stainless steel venting material **MUST BE USED**. Failure to follow this statement could result in product damage, severe personal injury, or death.

Failure to follow these instructions could result in property damage, severe personal injury, or death.

A. INTAKE PIPE AND EXHAUST VENT GUIDELINES

1. Vent system must be installed in accordance with local codes, or, in absence of local codes, the National Fuel Gas Code, ANSI Z223.1 / NFPA 54 and/or CSA B149.1, Natural Gas and Propane Installation Code.
2. **For installation in Canada**, installer supplied plastic vent piping must comply with CAN/CGA B149.1 and be certified to the Standard for Type BH Gas Venting Systems, ULC-S636. Components of this listed system must not be interchanged with other vent systems or unlisted pipes or fittings. All plastic components and specified primers and glues must be from a single system manufacturer and must not be intermixed with another system manufacturer's products. Clean and dry all applicable surfaces before applying cement.
3. This appliance is designed to be installed as a direct vent (sealed combustion) type. Combustion air must be supplied directly from the outdoors to the burner, and the flue (exhaust) gases should be vented directly to the outdoors through the wall or roof.
4. This appliance uses 2" or 3" diameter pipe for exhaust vent and intake pipe. It is important to ensure an airtight seal from the appliance collar to the vent terminations. See Table 9 for a list of Approved Vent Materials.
5. Do not install venting system components on the exterior of the building except as specifically required by these instructions.
 - Vent terminals must be at least 1 foot from any door, window, or gravity inlet into the building.
 - Maintain the correct clearance and orientation between the exhaust vent and intake pipe terminals.
 - The exhaust vent and air intake terminals must be at the same height and their center lines must be spaced apart 1 foot minimum.
 - The bottom of the exhaust vent and intake pipe terminals must be at least 1 foot above the normal snow accumulation level. In no case should these terminals be installed less than 1 foot above normal snow accumulation level.
 - Do not install the exhaust vent terminals directly above windows or doors.
 - Intake pipe terminal must not terminate in areas that might contain combustion air contaminants, such as near swimming pools.
 - For sidewall venting, the minimum horizontal distance between adjacent exhaust vent terminations is 1 foot. It is recommended this distance be greater than 1 foot to better avoid frost damage to building surfaces.
 - For roof venting, minimum horizontal distance between any adjacent exhaust vent termination is 1 foot.

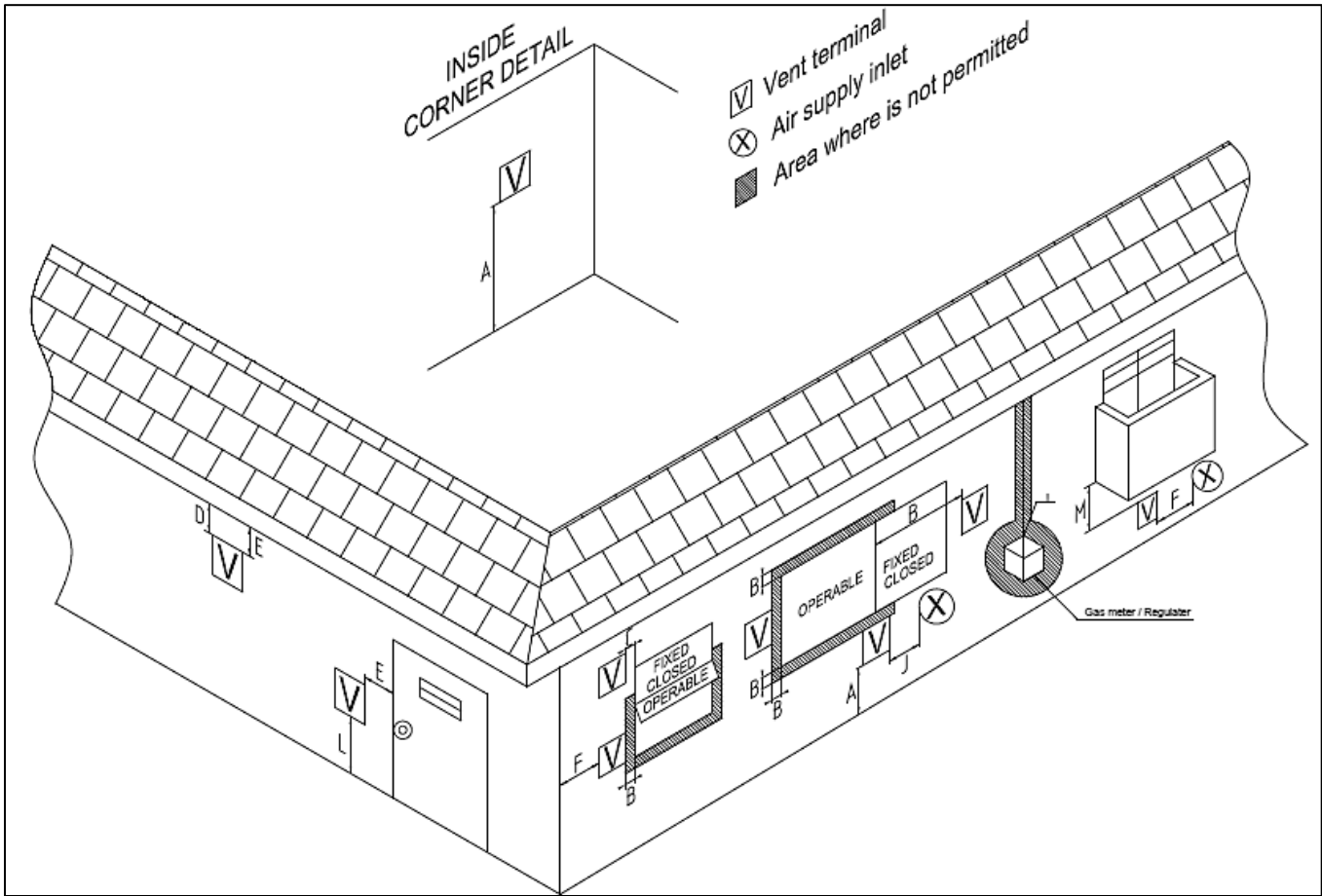

Figure 6 – Vent Termination Detail

| | DESCRIPTION | US | CANADA |
|---|--|---|---|
| A | Clearance above grade, veranda, porch, deck, or balcony | 1 foot | 1 foot |
| B | Clearance to window or door that may be opened | 1 foot | 3 feet |
| C | Clearance to permanently closed window | * | * |
| D | Vertical clearance to ventilated soffit located above the terminal within a horizontal distance of 2 feet from the center line of the terminal | * | * |
| E | Clearance to unventilated soffit | * | * |
| F | Clearance to outside corner | * | * |
| G | Clearance to inside corner | * | * |
| H | Clearance to each side of center line extended above meter / regulator assembly | * | 3 feet with a height 15 feet above meter / regulator assembly |
| I | Clearance to service regulator vent outlet | * | 3 feet |
| J | Clearance to non-mechanical air supply inlet to building or the combustion air inlet to any other appliance | 1 foot | 3 feet |
| K | Clearance to a mechanical air supply inlet | 3 feet above if within 10 feet horizontally | 6 feet |
| L | Clearance above paved sidewalk or driveway located | * | 7 feet |
| M | Clearance under veranda, porch, deck, or balcony | * | 1 foot |

Table 8 – Vent Termination Clearances

***NOTE:** For clearances not specified in ANSI Z223.1/NFPA 54 or CAN/CSA-B 149.1, please use clearances in accordance with local installation codes and the requirements of the gas supplier.

B. APPROVED VENT MATERIALS

NOTICE

Consult Table 9 or the most recent edition of ANSI Z223.1/NFPA 54 or CAN/CGA B149.1 as well as all applicable local codes and regulations when selecting vent pipe materials.

| APPROVED EXHAUST VENT AND INTAKE PIPE MATERIAL | | | |
|--|-------------------------|---|---|
| Item | Material | Standards for Installation in: | |
| | | United States | Canada |
| Exhaust vent or Intake pipe and fittings | CPVC schedule 40 | ASTM-D2846 | PP, CPVC, and PVC venting must be ULC-S636 Certified. IPEX is an approved manufacturer in Canada, supplying vent material listed to ULC-S636. |
| | PVC schedule 40 | ANSI/ASTM D1785 | |
| | Polypropylene | ULCS636 | |
| | Stainless Steel AL29-4C | Certified for Category IV and direct vent appliance venting | Certified for Category IV and direct vent appliance venting |
| Pipe cement/primer | PVC | ANSI/ASTM D2564 | IPEX System 636 Cements & Primers |
| | CPVC | ANSI/ASTM F493 | |

⚠ DANGER

- The exhaust and intake components installed with this appliance must be used for near appliance piping BEFORE transitioning to the approved materials listed above. DO NOT REMOVE these installed components. Doing so WILL VOID warranty.
- PVC/CPVC pipe and fittings of the same diameter are considered interchangeable.
- DO NOT use Foam Core Pipe (CPVC cellular core, Radel, etc.) in any portion of the exhaust piping from this appliance.
- DO NOT connect PVC/CPVC to PP without an approved vent connector.
- When installing AL29-4C vent piping, install a PVC-to-stainless adapter at the appliance vent connection, and at the termination when using a PVC termination kit. DO NOT mix AL-29-4C piping from different manufacturers unless using adapters specifically designed for the purpose by the manufacturer.
- DO NOT insulate non-metallic exhaust vent pipe or fittings.
- DO NOT obstruct the flow of combustion or ventilation air.
- When using Pipe Cement/Primer, follow the instructions included with the Cement/Primer closely. Clean and dry all applicable surfaces before applying.

Failure to follow these directions will result in substantial property damage, severe personal injury, or death.

Table 9 – Approved Venting Materials

⚠ WARNING

Vent adaptors are not designed as load-bearing devices, and must not be used to support exhaust vent piping. All vent pipes must be properly connected, supported, and the exhaust must be pitched a minimum of ¼” per foot back to the appliance to allow drainage of condensate. Failure to properly support vent piping and follow the information in this statement could result in product damage, severe personal injury, or death.

⚠ WARNING

For closet and alcove installations: CPVC, polypropylene, or stainless steel venting material MUST BE USED. Failure to follow this statement could result in product damage, severe personal injury, or death.

CAUTION

High heat sources (sources generating heat 100°F / 37°C or greater, such as stove pipes, space heaters, etc.) may damage plastic components of the appliance as well as plastic vent pipe materials. Such damages ARE NOT covered by warranty. It is recommended to keep a minimum clearance of 8” from high heat sources. Observe heat source manufacturer instructions, as well as local, state, provincial, and national codes, laws, regulations and ordinances when installing this appliance and related components near high heat sources.

C. ALLOWED COMBINED VENT LENGTHS

| 2” COMBINED VENT LENGTH MAXIMUM | 3” COMBINED VENT LENGTH MAXIMUM |
|------------------------------------|------------------------------------|
| 50’ (15M) | 100’ (30M) |

Table 10 – Approved Vent Lengths

NOTE: When using more than 1 elbow, reduce maximum allowable length:

- 5 feet (1.5M) for each additional 3” 90° elbow
- 2.5 feet (.75M) for each additional 3” 45° elbow
- 8 feet (2.4M) for each additional 2” 90° elbow
- 4 feet (1.2M) for each additional 2” 45° elbow

⚠ WARNING

Vent adaptors are not designed as load-bearing devices, and must not be used to support exhaust vent piping. All vent pipes must be properly connected, supported, and the exhaust must be pitched a minimum of ¼" per foot back to the appliance to allow drainage of condensate. Failure to properly support vent piping and follow the information in this statement could result in product damage, severe personal injury, or death.

D. TIGHTENING APPLIANCE COLLAR TO EXHAUST VENT AND INTAKE PIPE

NOTE: The included 6" length of 3" CPVC pipe MUST BE INSTALLED in the exhaust vent connection BEFORE venting the appliance.

⚠ WARNING

Failure to properly install the included 6" length of 3" CPVC pipe BEFORE venting the appliance could result in product damage, severe personal injury, or death.

This appliance uses 2" or 3" diameter pipe for exhaust vent and intake pipe. In order to use 2" pipe, it is required to reduce pipe size in a vertical length of pipe with a reducing coupling (not included). Follow the steps below to install 2" or 3" pipe into the appliance collar. See Figure 7 for additional details.

1. Clean and dry the appliance connection. DO NOT use primer or cement on the appliance connection.
2. Push the included 6" length of CPVC pipe into the connection until it touches the bottom of the fitting.
3. Tighten the clamps using a screwdriver.
4. Ensure the pipe is secure before continuing installation.
5. For 2" installations, install a reducing coupling in a vertical section of pipe. See Figure 8.

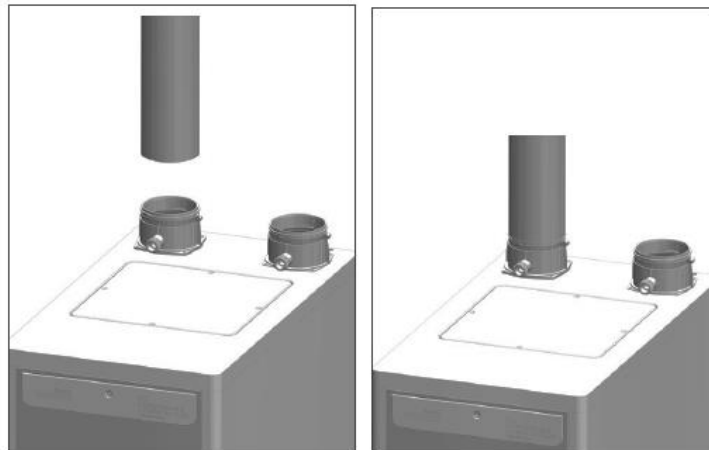

Figure 7 – Installing the 6" Length of CPVC into the Exhaust Vent Connection

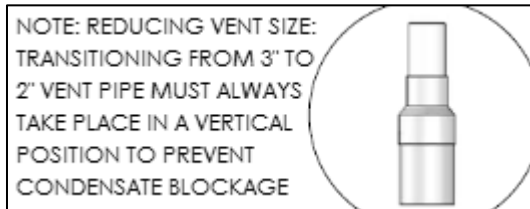

Figure 8 – Transitioning from 3" to 2" Vent Pipe

E. VENT TERMINATION

1. Horizontal Vent Terminations

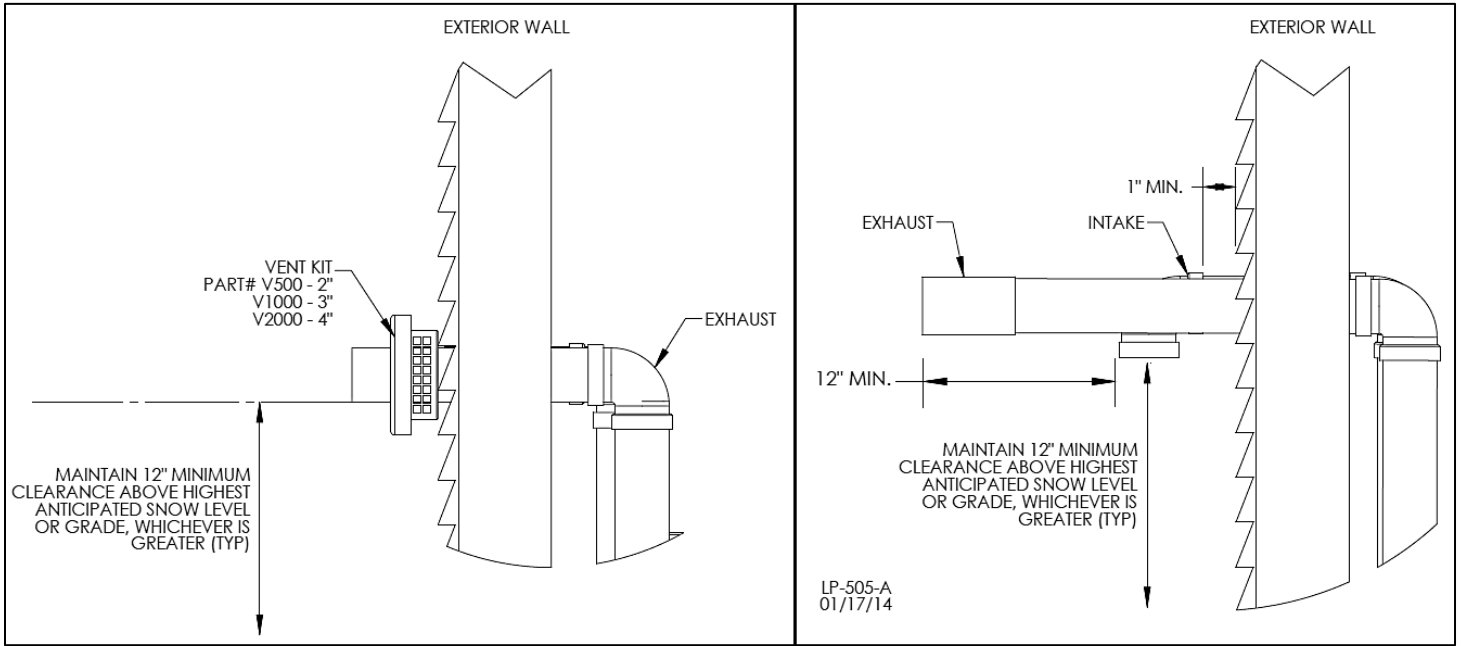

Figure 9 – Direct Vent, Sidewall Vent Termination

2. Vertical Vent Termination

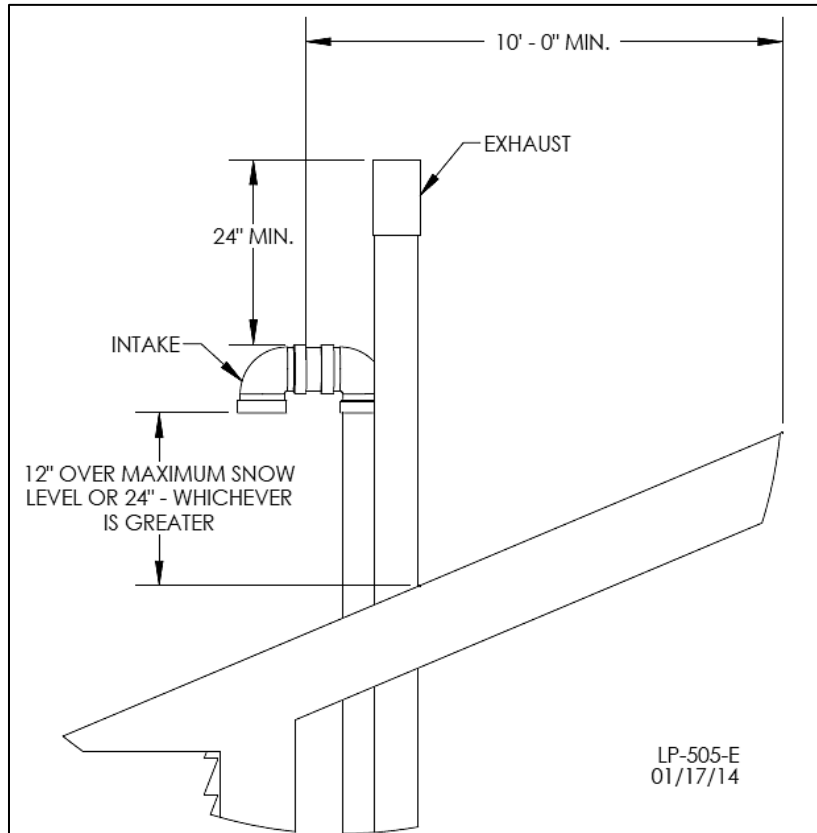

Figure 10 – Direct Vent, Vertical Termination

3. Direct Vent, Optional Horizontal and Vertical Concentric Vent

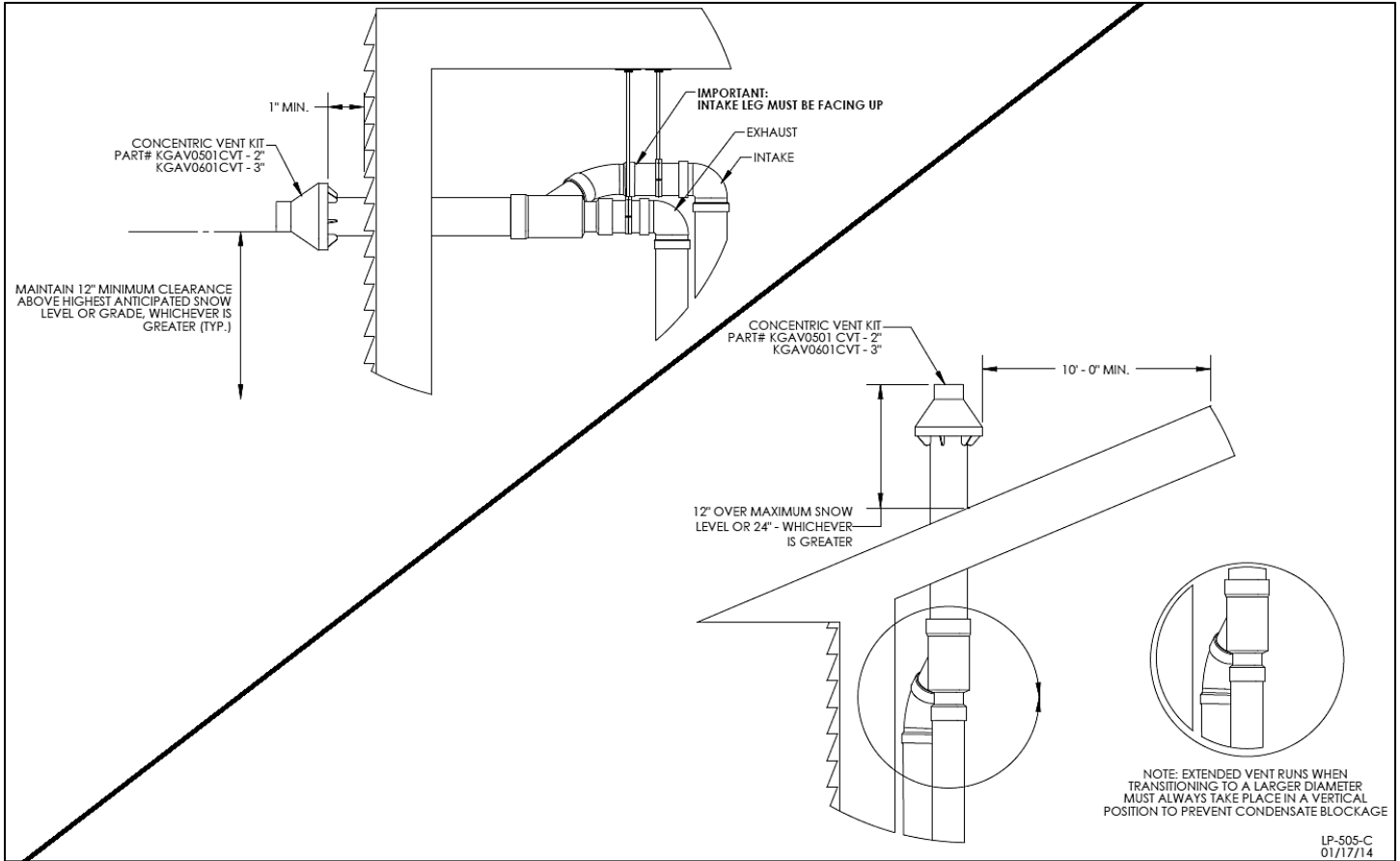

Figure 11 – Direct Vent, Concentric Vent Termination (With Optional Kit)

4. Screen Installation

After connecting the intake air and exhaust vent pipes, it is required to install the included screens into the exhaust vent and intake pipe terminations to prevent damages to the unit due to blockages. Clean the vent terminations and cement the screens into the terminations. See Figure 12 for installation detail.

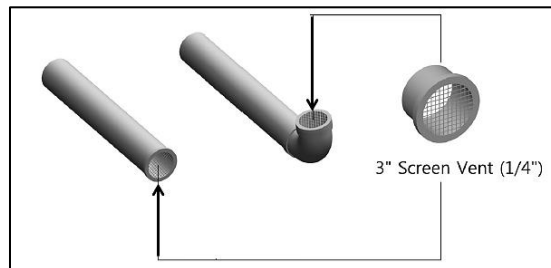

Figure 12 – Screen Installation

SAFETY INSTRUCTIONS

Do not connect any other appliance vents to the appliance exhaust vent or intake pipes.

PART 6 – INSTALL THE CONDENSATE DRAIN

1. Due to its efficient design, the appliance produces condensate (water) as a normal by-product. This condensate is acidic, with a pH level between 3 and 4. This condensate must be drained away from the appliance and disposed in accordance with all local regulations.

2. Use corrosion-resistant materials approved by the Authority Having Jurisdiction (AHJ) to drain condensate. In the absence of an AHJ, the included flexible plastic hose, or field supplied 1/2" PVC and CPVC drain pipe complying with ASTM D1785, F441, or D2665

may be used. Cement and primer must comply with ASTM D2564 or F493. For Canadian applications, use CSA or ULC certified PVC or CPVC pipe, fittings, and cement.

3. Local building codes may require an in-line neutralizer to be installed (not included) to treat the condensate. Follow all the installation instructions included with the neutralizer. If a neutralizer is installed, periodic replacement of the limestone (or neutralizing agent) will be required. The rate of depletion of the limestone varies with usage of the appliance. During the first year of appliance operation, check the neutralizer every few months for depletion.

4. Route the drain line to a nearby floor drain, laundry tub, or condensate pump.

NOTE: If a nearby laundry tub is used as a disposal for waste water from the washing machine, draining the condensate into this tub allows the soapy water discharge to neutralize the acidic condensate.

5. An error will appear on the appliance display if condensate line is blocked. The appliance will not operate with a blocked condensate line. It is extremely important to have this condition repaired by a qualified service technician.

NOTE: This appliance has an internal condensate trap that must be cleaned and maintained. See Maintenance section of this manual for instructions on maintaining the trap.

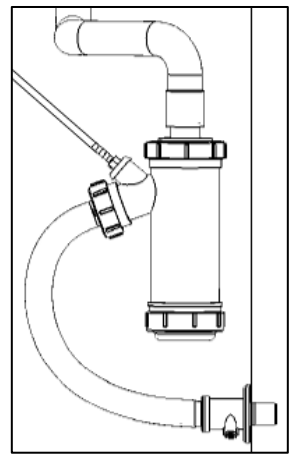

Figure 13 – Internal Condensate Trap

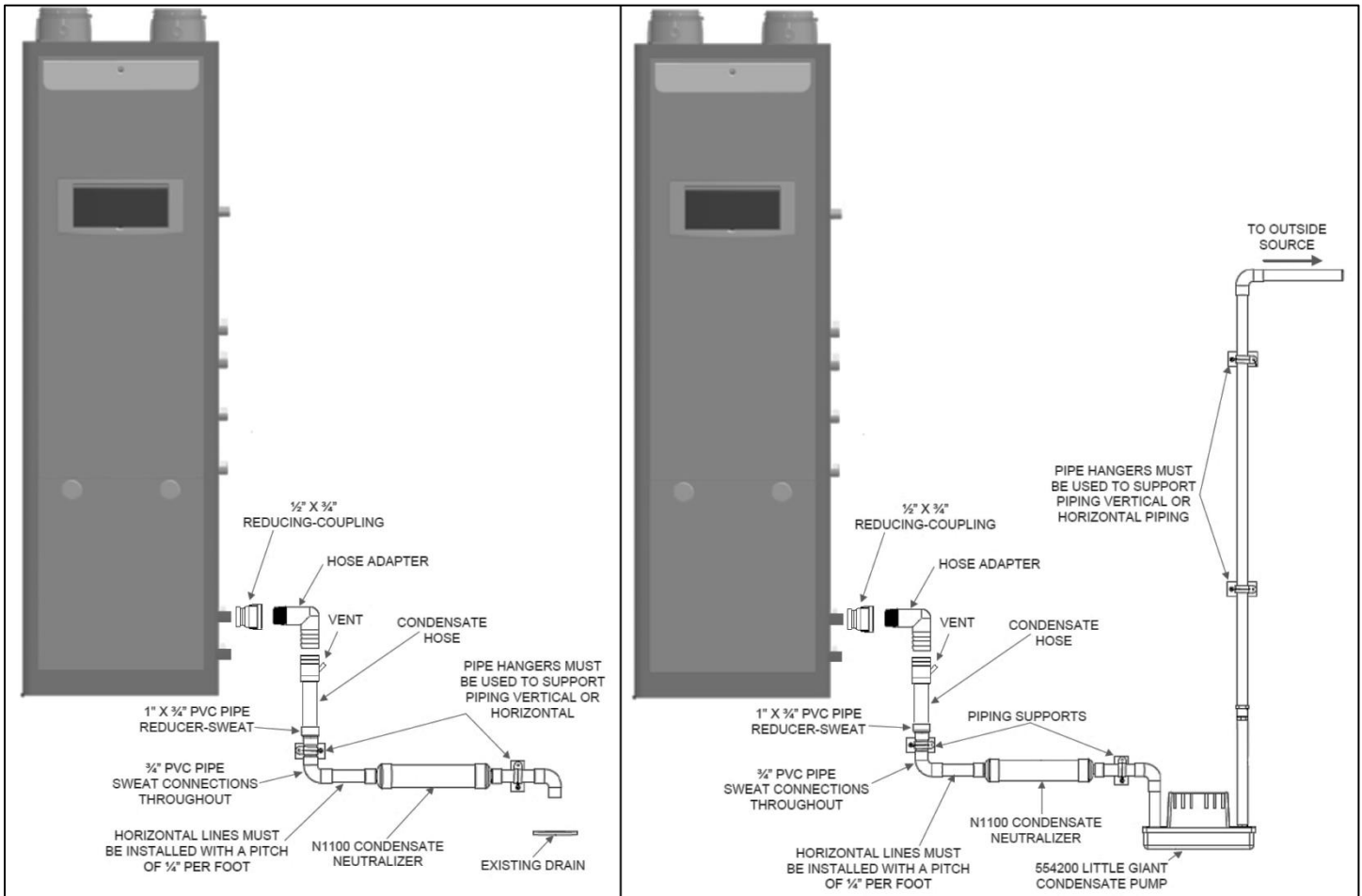

Figure 14 – Condensate Piping with Condensate Neutralizer / Condensate Piping with Condensate Neutralizer and Pump

NOTES:

1. Condensate line must be pitched at least 1/4" per foot to properly drain. If this cannot be done, or a very long length of condensate hose is used, you must increase the condensate line to a minimum of 1" ID and place a tee in the line after the condensate neutralizer to properly reduce vacuum lock in the drain line.
2. Plastic pipe should be the only material used for the condensate line. Steel, brass, copper, or other materials will be subject to corrosion or deterioration.
3. NEVER install condensate lines outside. It is very important that the condensate line is not exposed to freezing temperatures or any type of blockage. Damages due to frozen or blocked condensate lines ARE NOT covered by warranty.
4. Support of the condensate line may be necessary to avoid blockage of the condensate flow.

CAUTION

If using a condensate pump, select one approved for use with condensing boilers and furnaces. The pump should have an overflow switch to prevent property damage from condensate spillage.

CAUTION

It is very important that the condensate piping be no smaller than 3/4". To prevent sagging and maintain pitch, condensate piping should be supported with pipe supports, and pitched 1/4" per foot to allow for proper drainage.

CAUTION

The condensate line must remain unobstructed, allowing free flow of condensate. If condensate freezes in the line, or if line is obstructed in any other manner, condensate can exit from the tee, resulting in potential water damage to property.

PART 7 – GAS PIPING

⚠ WARNING

FIRE AND/OR EXPLOSION HAZARD

To avoid serious injury or death, the gas line installation and the gas line inlet pressure test must be done by a licensed professional. Always match the appliance with the type of gas supplied to the unit (natural gas or LP gas). This appliance must be converted into propane operation unless specifically manufactured for use with propane. Follow Gas Conversion Manual instructions (separate document). Propane ready appliances have the suffix "LP" after the model serial number. Make sure the gas line pressures are within normal limits. Pressures outside normal limits can result in poor performance and hazardous operating conditions. This appliance must be converted into propane operation unless it is specifically manufactured to operate on propane. Propane-ready appliances have the suffix "LP" after the model serial number. Failure to ensure the appliance is set to operate on the provided gas supply could result in property damage, personal injury, or death.

A. GAS PIPE SIZING TABLES

1. Gas Pipe Sizing

This information is for reference use only. Refer to gas pipe manufacturer specifications for actual delivery capacity. The DOE standard for Natural Gas is 1100 BTU/ft³. Contact the local gas supplier for actual BTU/ft³ rating.

2. Natural Gas Pipe Sizing

The following tables list maximum capacity of pipe in cubic feet of gas per hour for gas pressures of 0.5 psi or less and a pressure drop of 0.5 inches water column, based on a 0.60 specific gravity for natural gas.

| Maximum Natural Gas Delivery Capacity – Length of Corrugated Stainless Steel Pipe in Feet | | | | | | | | | | |
|--|--|-----------|-----------|-----------|-----------|-----------|-----------|------------|------------|------------|
| Pipe Size | Cubic Feet per Hour (0.60 Specific Gravity, 0.5 WC Pressure Drop) | | | | | | | | | |
| | 10 | 20 | 30 | 40 | 50 | 60 | 80 | 100 | 150 | 200 |
| 1/2" | 82 | 58 | 47 | 41 | 37 | 37 | 29 | 26 | 20 | 18 |
| 3/4" | 192 | 137 | 112 | 97 | 87 | 80 | 69 | 62 | 48 | 44 |
| 1" | 383 | 269 | 218 | 188 | 168 | 153 | 132 | 118 | 91 | 82 |
| 1 1/4" | 639 | 456 | 374 | 325 | 292 | 267 | 232 | 208 | 171 | 148 |
| 1 1/2" | 1260 | 888 | 723 | 625 | 559 | 509 | 440 | 393 | 320 | 277 |
| 2" | 2930 | 2080 | 1700 | 1470 | 1320 | 1200 | 1040 | 933 | 762 | 661 |

Table 11 – Natural Gas Delivery Capacity – Corrugated Stainless Steel Pipe – Refer to ANSI Z223.1 – National Fuel Gas Code, Latest Edition

| Maximum Natural Gas Delivery Capacity – Length of Black Iron Pipe (Sch. 40 Metallic) in Feet | | | | | | | | | | |
|---|--|-----------|-----------|-----------|-----------|-----------|-----------|------------|------------|------------|
| Pipe Size | Cubic Feet per Hour (0.60 Specific Gravity, 0.5 WC Pressure Drop) | | | | | | | | | |
| | 10 | 20 | 30 | 40 | 50 | 60 | 80 | 100 | 150 | 200 |
| 1/2" | 172 | 118 | 95 | 81 | 72 | 65 | 56 | 50 | 40 | 34 |
| 3/4" | 360 | 247 | 199 | 170 | 151 | 137 | 117 | 104 | 83 | 71 |
| 1" | 678 | 466 | 374 | 320 | 284 | 257 | 220 | 195 | 157 | 134 |
| 1 1/4" | 1390 | 957 | 768 | 657 | 583 | 528 | 452 | 400 | 322 | 275 |
| 1 1/2" | 2090 | 1430 | 1150 | 985 | 873 | 791 | 677 | 600 | 482 | 412 |
| 2" | 4020 | 2760 | 2220 | 1900 | 1680 | 1520 | 1300 | 1160 | 928 | 794 |

Table 12 – Natural Gas Delivery Capacity – Black Iron Pipe – Refer to ANSI Z223.1 – National Fuel Gas Code, Latest Edition

3. LP (Liquid Propane) Gas Pipe Sizing

The following is intended for use for piping between a Single or Second Stage (Low Pressure) Regulator and the appliance. The following tables list maximum capacity of pipe in cubic feet of gas per hour for an inlet pressure of 11 inches water column and specific pressure drop of 0.5 inches water column based on 1.5 specific gravity for liquid propane.

| Maximum Liquid Propane Delivery Capacity – Length of Corrugated Stainless Steel Pipe in Feet | | | | | | | | | | |
|--|---|------|------|------|------|------|------|------|------|------|
| Pipe Size | Cubic Feet per Hour (0.60 Specific Gravity, 0.5 WC Pressure Drop) | | | | | | | | | |
| | 10 | 20 | 30 | 40 | 50 | 60 | 80 | 100 | 150 | 200 |
| ½" | 129 | 91 | 74 | 64 | 58 | 53 | 45 | 41 | 31 | 28 |
| ¾" | 303 | 216 | 177 | 153 | 137 | 126 | 109 | 98 | 75 | 69 |
| 1" | 605 | 425 | 344 | 297 | 265 | 241 | 208 | 186 | 143 | 129 |
| 1 ¼" | 971 | 661 | 528 | 449 | 397 | 359 | 307 | 270 | 217 | 183 |
| 1 ½" | 1990 | 1400 | 1140 | 988 | 884 | 805 | 696 | 621 | 506 | 438 |
| 2" | 4640 | 3290 | 2680 | 2330 | 2080 | 1900 | 1650 | 1480 | 1210 | 1050 |

Table 13 – Liquid Propane Delivery Capacity – Corrugated Stainless Steel Pipe – Refer to ANSI Z223.1 – National Fuel Gas Code, Latest Edition

| Maximum Liquid Propane Delivery Capacity – Length of Black Iron Pipe (Sch. 40 Metallic) in Feet | | | | | | | | | | |
|---|---|------|------|------|------|------|------|------|------|------|
| Pipe Size | Cubic Feet per Hour (0.60 Specific Gravity, 0.5 WC Pressure Drop) | | | | | | | | | |
| | 10 | 20 | 30 | 40 | 50 | 60 | 80 | 100 | 150 | 200 |
| ½" | 291 | 200 | 160 | 137 | 122 | 110 | 101 | 94 | 84 | 67 |
| ¾" | 608 | 418 | 336 | 287 | 255 | 231 | 212 | 197 | 175 | 140 |
| 1" | 1150 | 787 | 632 | 541 | 480 | 434 | 400 | 372 | 330 | 265 |
| 1 ¼" | 2350 | 1620 | 1300 | 1110 | 985 | 892 | 821 | 763 | 677 | 543 |
| 1 ½" | 3520 | 2420 | 1940 | 1660 | 1480 | 1340 | 1230 | 1140 | 1010 | 814 |
| 2" | 6790 | 4660 | 3750 | 3210 | 2840 | 2570 | 2370 | 2200 | 1950 | 1570 |

Table 14 – Liquid Propane Delivery Capacity – Black Iron Pipe – Refer to ANSI Z223.1 – National Fuel Gas Code, Latest Edition

B. GAS CONNECTION REQUIREMENTS

1. The gas connection fitting on the appliance is ½" male NPT. A ½" X ¾" Bell Coupling has been provided with the appliance to aid installation. **NOTE:** The pipe size must not be less than ½".
2. The supply line must be sized for the maximum output of the appliance being installed. If there are additional gas appliances from the main supply line, measure the size of the supply line according to the COMBINED total maximum BTUH draw for the appliances as if they were operating at the same time.
3. Measure the length of the gas supply line from the gas meter to the appliance. Appliance must be installed downstream of the gas meter to ensure adequate gas supply. Use the tables in this manual or refer to the gas line manufacturer's sizing information to determine the correct supply pipe size.
4. A manual gas shut-off valve should be installed in the gas supply line close to the appliance. See Figure 15 for detail.
5. To facilitate any future maintenance, it is also recommended that an approved gas union fitting be installed in the supply line between the shut-off valve and the connection on the appliance.
6. Test the gas pressure to make sure it meets the minimum standards and does not exceed the maximum standards of the appliance.
7. Leak test the gas line pipe before placing the appliance in operation. Only use approved leak detector liquid solutions to check for leaks.
8. Do not operate the appliance until all connections have been completed and the heat exchanger is filled with water.

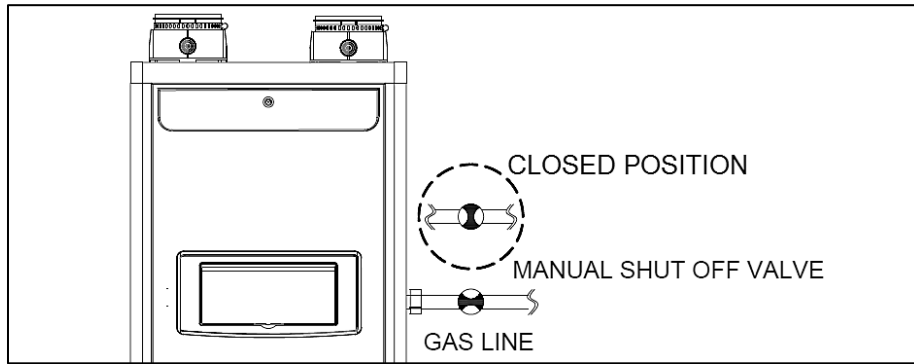

Figure 15 – Gas Line with Shut-Off Valve Detail

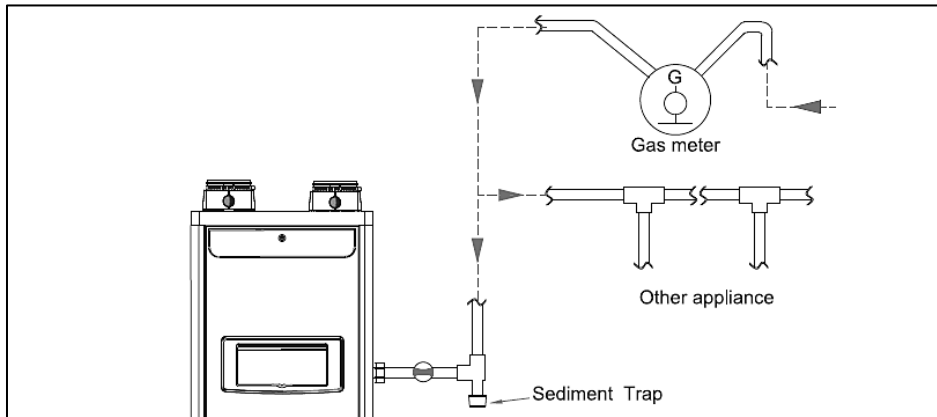

Figure 16 – Natural Gas Piping Installation – NOTE: Capacity to be Not Less than Total Capacity of Connected Appliances

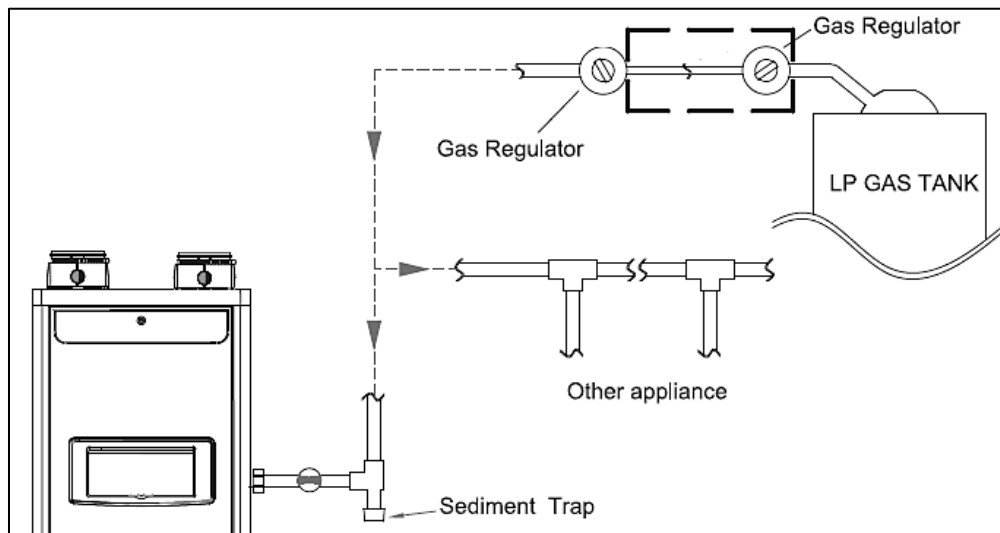

Figure 17 – LP Gas Piping Installation – NOTE: Capacity to be Not Less than Total Capacity of Connected Appliances

PART 8 – WATER PIPING

A. GENERAL PLUMBING CONNECTION GUIDELINES

- Pipe material must be suitable to meet local codes and industry standards.
- The pipe must be cleaned and without blemish before any connections are made.
- Do not apply a torch within 12" of the appliance. Doing so could damage the appliance. Such damages ARE NOT covered by product warranty.
- The size of the hot water pipe should be ¾" diameter and the central heating water pipe should be 1" in diameter.
- To ease future maintenance isolation valves are recommended on both the CH and DHW loops.
- All piping should be insulated.

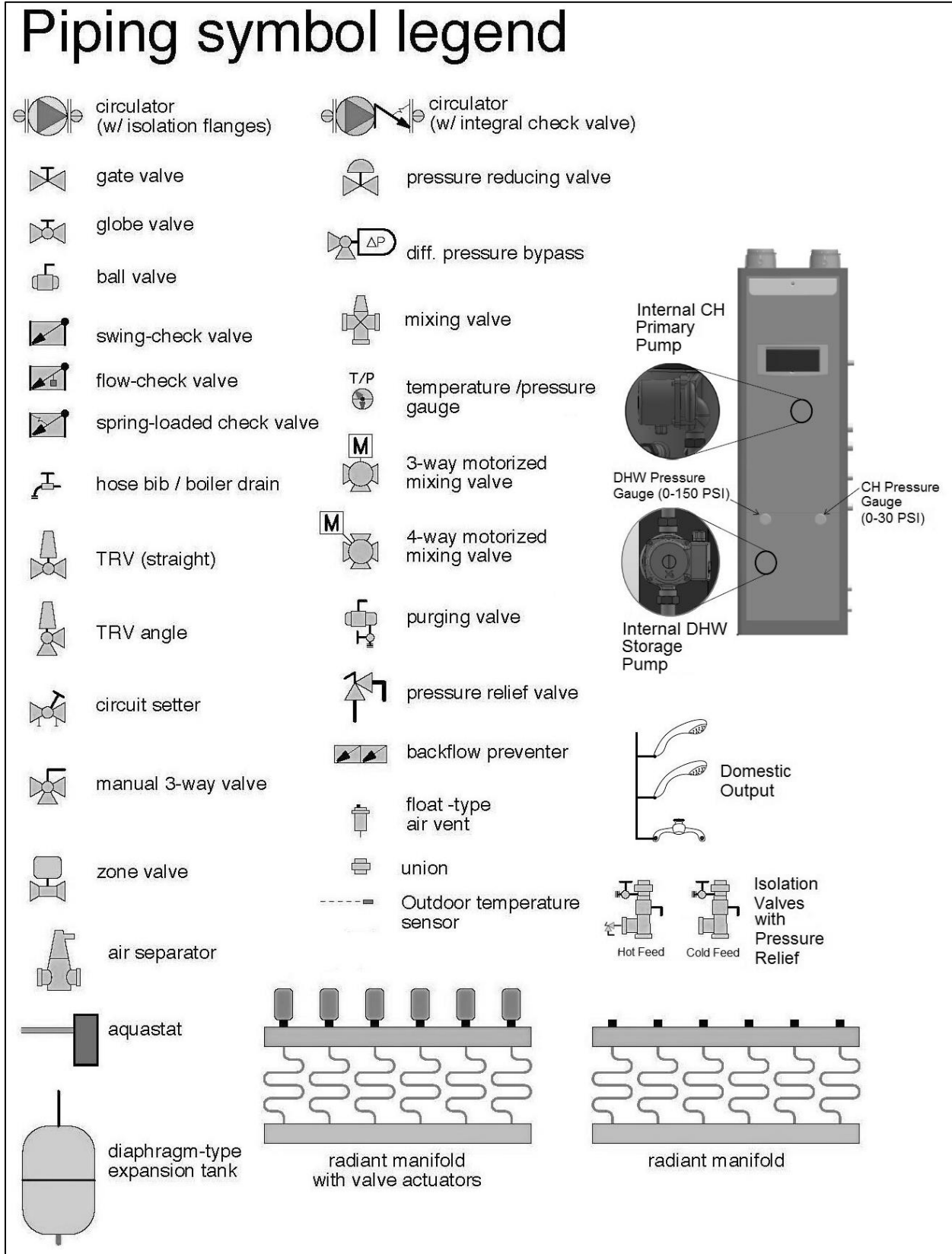

Figure 18 – Piping Legend

B. DHW PIPING

Use both thread tape and pipe dope to connect to the 3/4" domestic water inlet and outlet. A shut off valve between the city water supply and DHW inlet is recommended for ease of service.

It may be recommended to use a back flow preventer – check local codes. If a back flow preventer or a no return valve is used, a thermal expansion tank must be installed on the cold water supply between the appliance and valve.

WARNING

To control thermal expansion, a thermal expansion tank suitable for potable water should be installed in systems with an installed backflow preventer. **DO NOT** use a closed type expansion tank. Follow expansion tank manufacturer's specifications to properly size an expansion tank to the installation. Failure to properly accommodate thermal expansion could result in property damage, severe personal injury, or death.

C. CENTRAL HEATING PIPING SYSTEM WATER PIPING METHODS

EXPANSION TANK AND MAKE-UP WATER

1. Ensure that the expansion tank is designed and sized to correctly handle system water volume and temperature.

WARNING

Expansion tanks must be sized according to total system volume. This includes all length of pipe, all fixtures, appliances, etc. Failure to properly size system expansion could result in wasted time, money, and possible property damage, personal injury, or death.

CAUTION

Undersized expansion tanks cause system water to be lost from the relief valve, causing make-up water to be added. Eventual appliance failure can result due to excessive make-up water addition. **SUCH FAILURE IS NOT COVERED BY WARRANTY.**

2. The expansion tank must be located following recognized design methods. See expansion tank manufacturer's instructions for details.
3. Connect the expansion tank to the air separator only if the air separator is on the suction side of the circulator. Always install the system fill connection at the same point as the expansion tank connection to the system.

CAUTION

DO NOT install automatic air vents on closed type expansion tank systems. Air must remain in the system and return to the tank to provide an air cushion. An automatic air vent would cause air to leave the system, resulting in improper operation of the expansion tank.

DIAPHRAGM (OR BLADDER) EXPANSION TANK

Always install an automatic air vent on top of the air separator to remove residual air from the system.

CAUTION

Use at least the MINIMUM pipe size for all appliance loop piping (connecting appliance to and from the primary/secondary connection). **DO NOT** pipe the appliance in any configuration other than primary/secondary. All piping methods shown in this manual use primary/secondary connection. This is to avoid the possibility of inadequate flow through the appliance. Using less than the required minimum pipe size and piping in anything other than a primary/secondary installation could result in system problems, property damage, and premature appliance failure. Such problems ARE NOT covered by product warranty.

Use both thread tape and pipe dope to connect to the 1" heating water outlet and inlet.

Primary / Secondary Piping with Zone Valves

DHW Priority Outdoor Reset

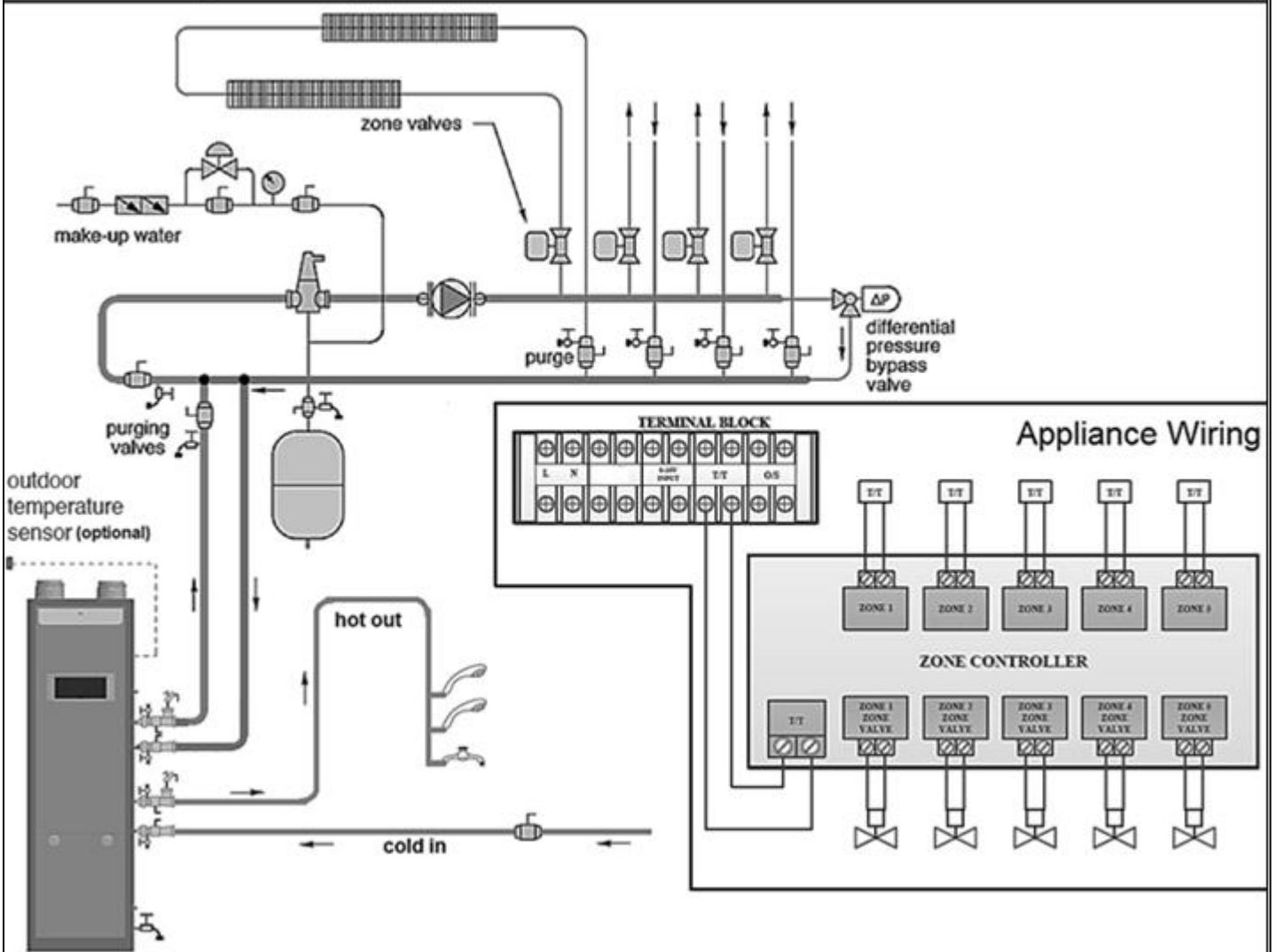

Figure 19 – CH and DHW Piping

NOTES:

1. This drawing is meant to show system piping concept only. Installer is responsible for all equipment and detailing required by local codes.
2. All closely spaced tees shall be within 4 pipe diameters center to center spacing.
3. A minimum of 6 pipe diameters of straight pipe shall be installed upstream and downstream of all closely spaced tees.
4. The **minimum** pipe size of DHW piping should be 3/4" diameter and CH piping should be 1" in diameter.
5. Circulators are shown with isolation flanges. The alternative is standard flanges with full port ball valves. Purge valves can be used with circulator flanges as an alternative.
6. Piping shown is Primary/Secondary. System flow (secondary loop) must be greater than the appliance's primary loop flow.
7. Install a minimum of 12 diameters of straight pipe upstream of all circulators.
8. **VERY IMPORTANT** – Minimum flow rates outlined in this manual must be maintained through the heat exchanger to minimize short cycling.
9. In a valve-based system, each heating zone has a zone valve which opens when that zone calls for heat. Each zone thermostat is wired to its corresponding zone valve. Contacts in the zone valves provide a signal to the appliance to operate when there is a call for heat.

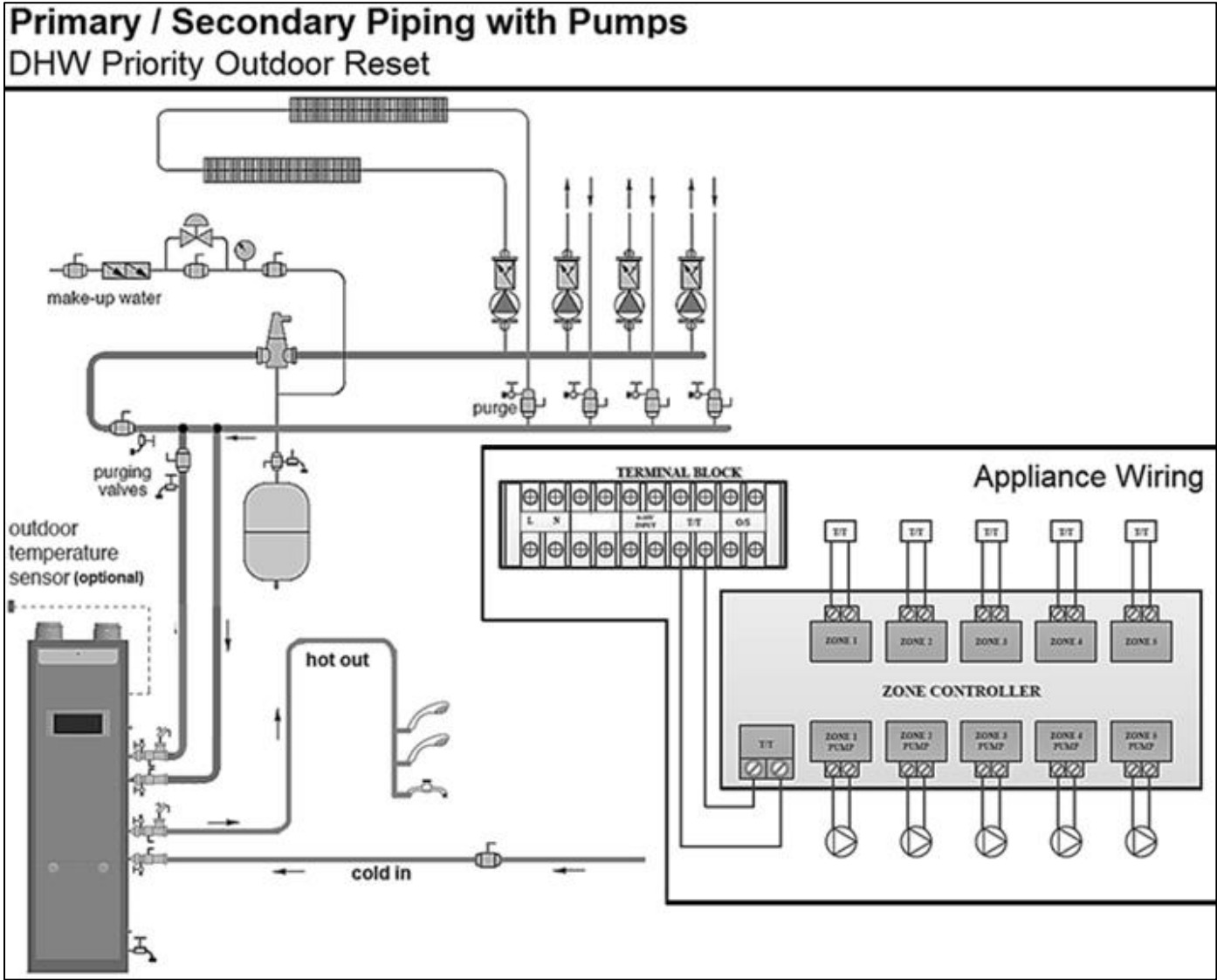

Figure 20 – CH Piping – Zoning with Pumps

NOTES:

1. This drawing is meant to show system piping concept only. Installer is responsible for all equipment and detailing required by local codes.
2. All closely spaced tees shall be within 4 pipe diameters center to center spacing.
3. A minimum of 6 pipe diameters of straight pipe shall be installed upstream and downstream of all closely spaced tees.
4. The **minimum** pipe size of DHW piping should be 3/4" diameter and CH piping should be 1" in diameter.
5. Circulators are shown with isolation flanges. The alternative is standard flanges with full port ball valves. Purge valves can be used with circulator flanges as an alternative.
6. Piping shown is Primary/Secondary. System flow (secondary loop) must be greater than the appliance's primary loop flow.
7. Install a minimum of 12 diameters of straight pipe upstream of all circulators.
8. **VERY IMPORTANT** – Minimum flow rates outlined in this manual must be maintained through the heat exchanger to minimize short cycling.
9. Each heating zone of a pump-based system has its own circulator with turns on when a zone thermostat calls for heat.

Primary / Secondary Piping with Pumps

DHW Priority With Outdoor Reset and Recirculation

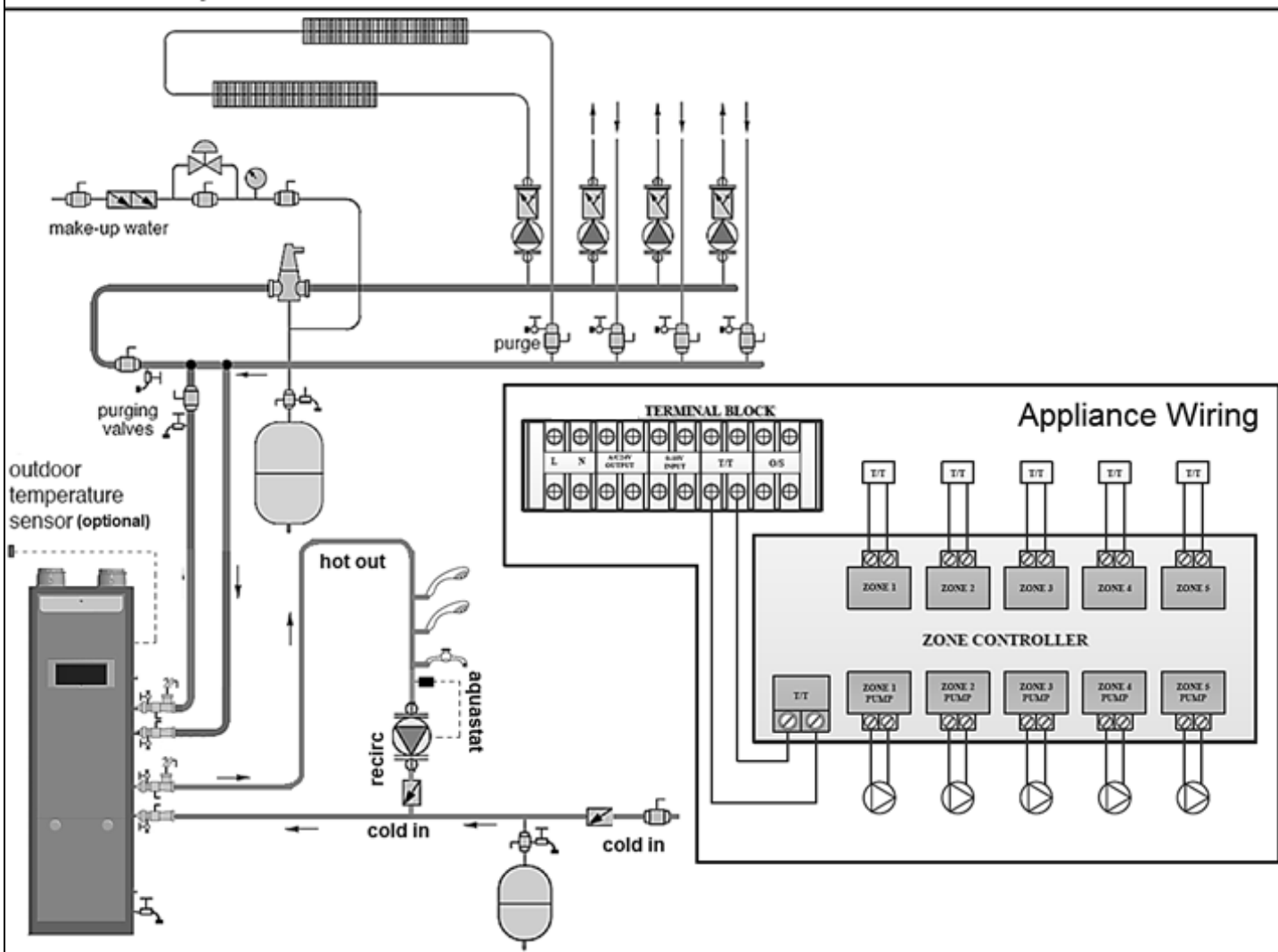

Figure 21 – DHW Priority with Outdoor Reset and Recirculation

NOTES:

1. This drawing is meant to show system piping concept only. Installer is responsible for all equipment and detailing required by local codes.
2. All closely spaced tees shall be within 4 pipe diameters center to center spacing.
3. A minimum of 6 pipe diameters of straight pipe shall be installed upstream and downstream of all closely spaced tees.
4. The **minimum** pipe size of DHW piping should be $\frac{3}{4}$ " diameter and CH piping should be 1" in diameter.
5. Circulators are shown with isolation flanges. The alternative is standard flanges with full port ball valves. Purge valves can be used with circulator flanges as an alternative.
6. Piping shown is Primary/Secondary. System flow (secondary loop) must be greater than the appliance's primary loop flow.
7. Install a minimum of 12 diameters of straight pipe upstream of all circulators.
8. **VERY IMPORTANT** – Minimum flow rates outlined in this manual must be maintained through the heat exchanger to minimize short cycling.
9. Each heating zone of a pump-based system has its own circulator with turns on when a zone thermostat calls for heat.

D. CIRCULATOR SIZING

The heat exchanger has a pressure drop that must be considered in your system design. Refer to Table 15 for pressure drop through the heat exchanger.

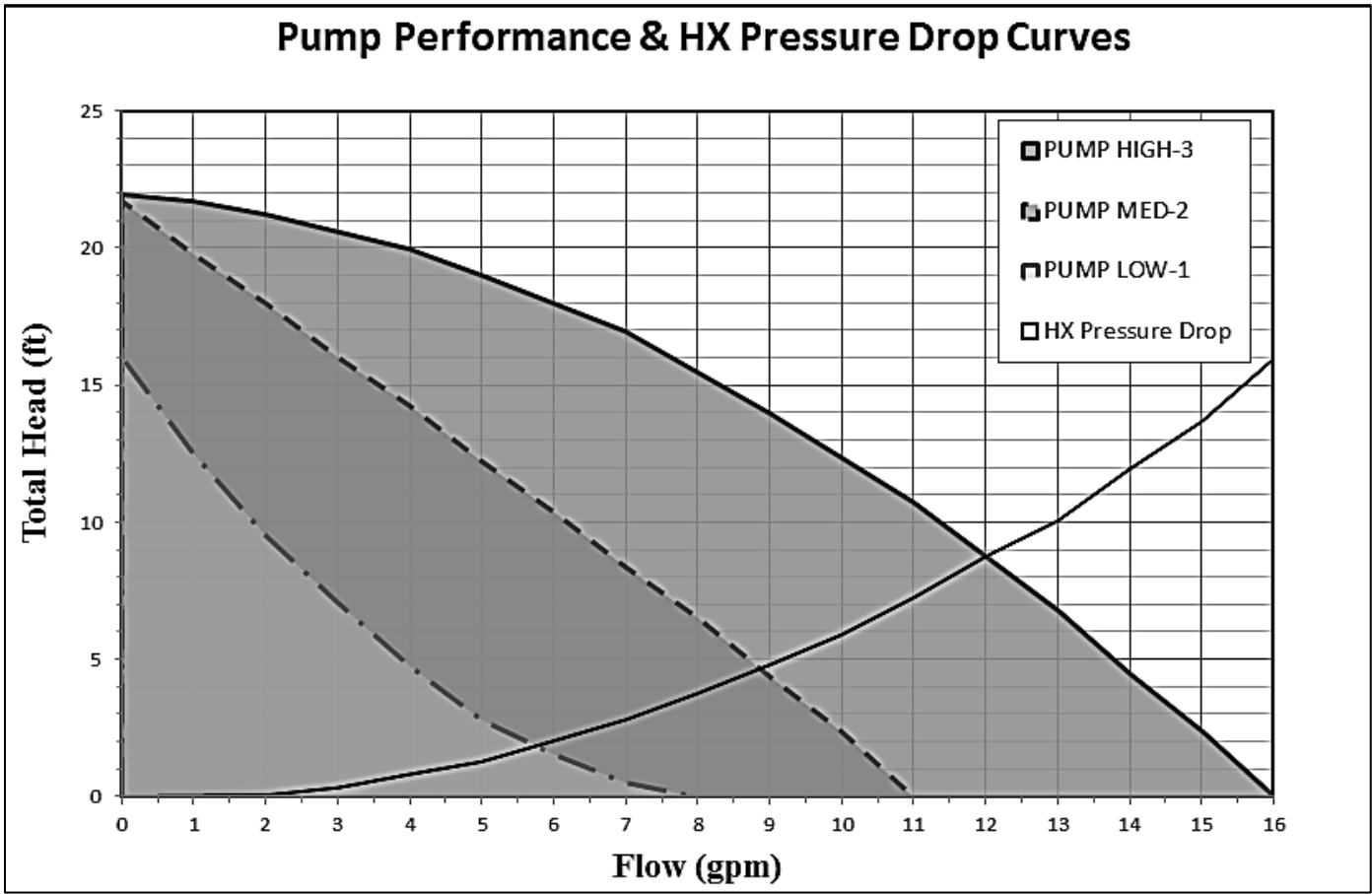

| SYSTEM TEMPERATURE CHART | | | | | |
|--------------------------|-----------|-----------------|-----------|-----------------|-----------|
| 20°F | | 25°F | | 30°F | |
| Min. Flow (GPM) | Head (ft) | Min. Flow (GPM) | Head (ft) | Min. Flow (GPM) | Head (ft) |
| 12.9 | 10 | 10.3 | 6 | 8.6 | 4 |

Table 15 – System Temperature Chart

E. PRESSURE RELIEF VALVE

An external pressure relief valve must be installed on this appliance. When installing, observe the following guidelines. Failure to comply with these guidelines can result in substantial property damage, personal injury, or death.

This appliance is provided with a CH pressure relief valve that complies with the ANSI/ASME Appliance and Pressure Vessel Code, Section IV (Heating Appliances). The included 30 psi CH Pressure Relief Valve must be installed on the CH supply line to ensure a compliant installation and safe operation. Westinghouse has supplied a 3/4" X 1" bushing to aid installation of the CH Pressure Relief Valve. The valve is meant to be field installed.

This appliance has a high-temperature shut-off switch built in as a standard safety feature. Therefore, a "pressure only" relief valve is required. DO NOT operate this appliance before the supplied pressure relief valve is installed with sufficient relieving capacity in accordance with the ASME rating plate on the appliance.

Pressure relief valves must be installed as close to the appliance as possible. No other valves should be placed between the pressure relief valve and the appliance. DO NOT install a CH pipe line relief valve with a pressure rating greater than 30 psi, or a DHW relief valve with a pressure rating greater than 150 psi. These are the maximum allowable relief valve settings for this appliance. A DHW pressure relief valve is not included with the appliance, and is to be field supplied and installed.

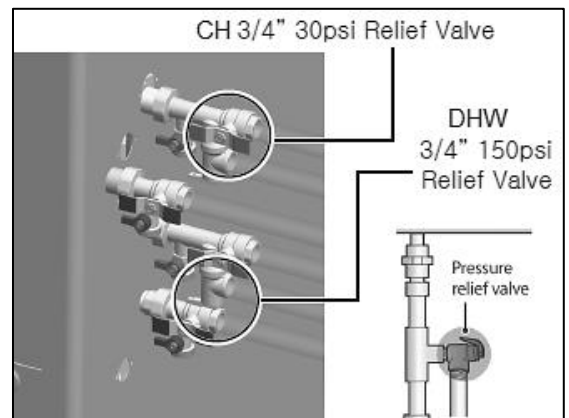

Figure 22 – Relief Valve Details

After installing the relief valve and filling and pressurizing the system, test the operation of the valve by lifting the lever. Make sure the valve discharges freely. If the valve fails to operate correctly, replace it with a new relief valve. Ensure that the maximum BTU/H rating

on the pressure relief valve is equal to or greater than the maximum input BTU/H rating of the combination appliance.

WARNING

To avoid water damage or scalding due to relief valve operation:

- Discharge line must be connected to relief valve outlet and run to a safe place of disposal. Terminate the discharge line in a manner that will prevent possibility of severe burns or property damage should the relief valve discharge.
- Discharge line must be as short as possible and the same size as the valve discharge connection throughout its entire length.
- Discharge line must pitch downward from the valve and terminate at least 6" above the floor drain, making discharge clearly visible.
- Discharge line shall terminate plain, not threaded, with a material serviceable for temperatures of 375°F or greater.
- Do not pipe discharge to any location where freezing could occur.
- No shutoff valve may be installed between the relief valve and appliance or in the discharge line. Do not plug or place any obstruction in the discharge line.
- Test the operation of the relief valve after filling and pressurizing the system by lifting the lever. Make sure the valve discharges freely. If the valve fails to operate correctly, replace it with a new relief valve.
- Test relief valve at least once annually to ensure the waterway is clear. If valve does not operate, turn the appliance "off" **and call a plumber immediately.**
- Take care whenever operating relief valve to avoid scalding injury or property damage.
- For appliances installed with only a pressure relief valve, the separate storage vessel must have a temperature and pressure relief valve installed. This relief valve shall comply with *Relief Valves for Hot Water Supply Systems, ANSI Z21.22 CSA4.4.*

FAILURE TO COMPLY WITH THE ABOVE GUIDELINES COULD RESULT IN FAILURE OF RELIEF VALVE OPERATION, RESULTING IN POSSIBILITY OF SUBSTANTIAL PROPERTY DAMAGE, SEVERE PERSONAL INJURY, OR DEATH.

PART 9 – CONNECT ELECTRICAL POWER / INITIAL STARTUP

WARNING

Install wiring and electrically ground appliance in accordance with the authority having jurisdiction or, in the absence of such an authority, follow the National Electrical Code, NFPA 70, and/or CSA C22.1 Electrical Code-Part 1 in Canada. Failure to follow all applicable local, state, and national regulations, mandates, and building supply codes for guidelines to install the electrical power supply could result in property damage, serious personal injury, or death.

WARNING

ELECTRICAL SHOCK HAZARD – To ensure safety, turn off electrical power supply at service entrance panel before making any electrical connections to avoid possible electric shock hazard. Failure to do so could result in property damage, serious personal injury, or death.

A. GENERAL OPERATING CONDITIONS

- Temperature
 - Operating Ambient Temperature Range: 14 – 140°F (-10 to 60°C)
 - Operating Relative Humidity: Up to 90% at 104°F (40°C)

B. WIRING INFORMATION

1. This appliance must be properly grounded. Ensure the electrical outlet (120V / 15 Amp minimum) that the appliance will be plugged into is properly grounded.

WARNING

This appliance is equipped with a three prong plug. It should only be plugged directly into a properly grounded three prong receptacle. **DO NOT** remove the ground plug from the plug. Doing so could result in property damage, serious personal injury, or death.

2. The wiring diagrams contained in this manual are to be used for reference purposes only.

3. Refer to these diagrams and the wiring diagrams of any external controls used with the installation when wiring the appliance. Read, understand, and follow all wiring instructions supplied with the controls.

4. Do not disconnect the power supply when the appliance is in normal operation.

NOTE: For additional electrical protection, the use of a surge protector is recommended. Damage caused by power surges is not covered by the warranty.

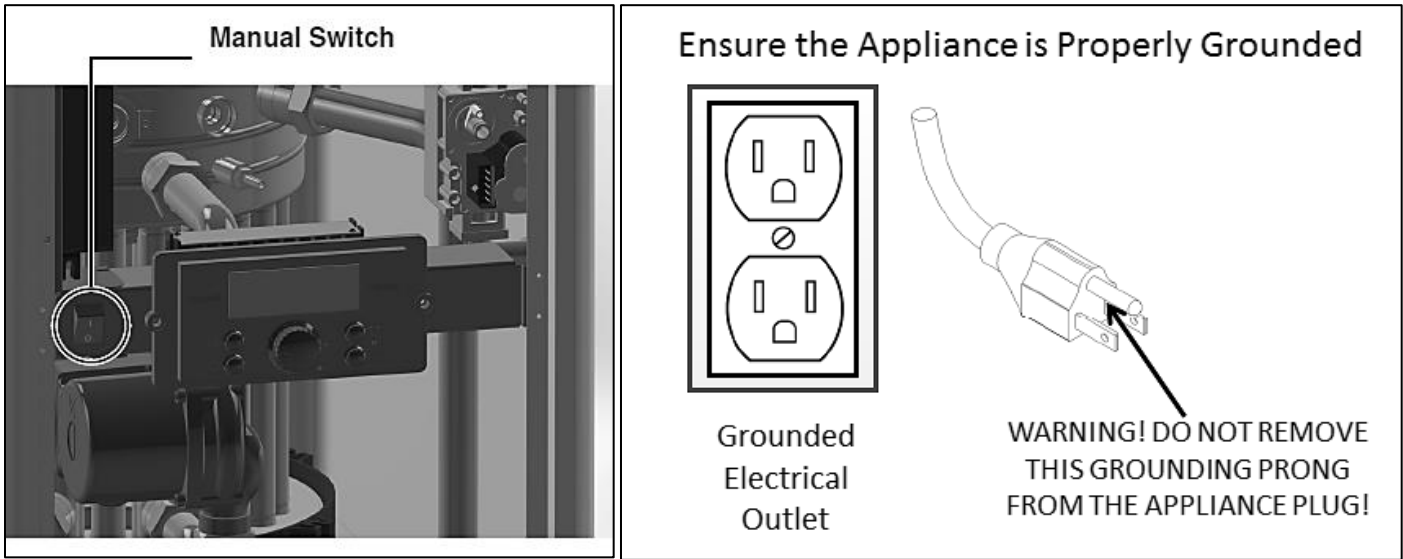

Figure 23 – Manual Power Switch and Appliance Plug Details

NOTICE

If the appliance display does not come ON, first check the plug. Then check the electrical panel circuit breaker and reset it if necessary. If the circuit breaker trips again, do not reset. Disconnect the plug and have a qualified technician diagnose the problem.

C. DIP SWITCHES

There is one set of DIP switches. The appliance is default set at the factory to operate on Natural Gas with a 3" vent.



Figure 24 – Dip Switch Detail

DIP SWITCH GROUP

| DIP SWITCH | | OFF | ON |
|------------|-------------|------------------|-----------|
| 1 – 3 | DO NOT MOVE | DO NOT MOVE | |
| 4 | Vent Size | 2" | 3" |
| 5 | Gas Type | LP | NG |
| 6 | High Fire | Normal Operation | High Fire |
| 7 | Low Fire | Normal Operation | Low Fire |

Table 16 – DIP Switch Group

SYSTEM CONTROL SETTINGS

| | |
|--|--|
| MAXIMUM FLAME DETECTING VOLTAGE | 2.5V |
| PRE-PURGE TIME (Tp) | Maximum 10 seconds, minimum 1 second |
| SAFETY TIME (IGNITING TIME) (Ts) | 3.5 seconds |
| IGNITING INTERVAL TIME | 10 seconds |
| POST-PURGE TIME (Tip) | 2 minutes (1 st : 1 minute, 2 nd : 1 minute) |
| OVER-HEATING 1,2,3 PROTECTION DETECTION TIME | <3 seconds |
| PUMP 1 POST CIRCULATING TIME (T1pv) | 1 minute |
| PUMP 2 POST CIRCULATING TIME (T2pv) | 1 minute |
| HIGH AND LOW WATER LEVEL DETECTION TIME | <6 seconds |
| HIGH AND LOW WATER LEVEL RECOVERY TIME | <6 seconds |

Table 17 – System Control Settings

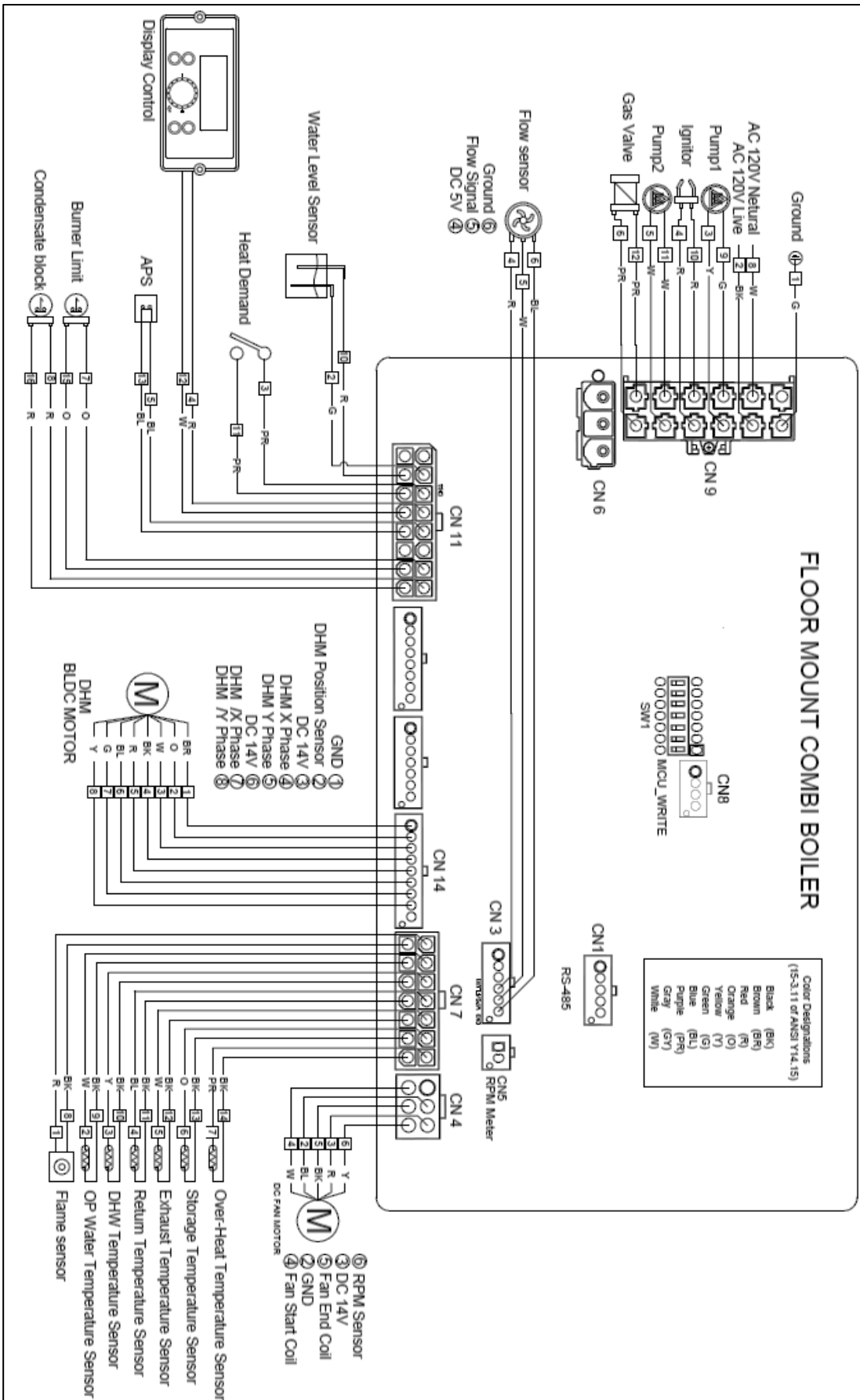

Figure 25 – Electrical Wiring Diagram

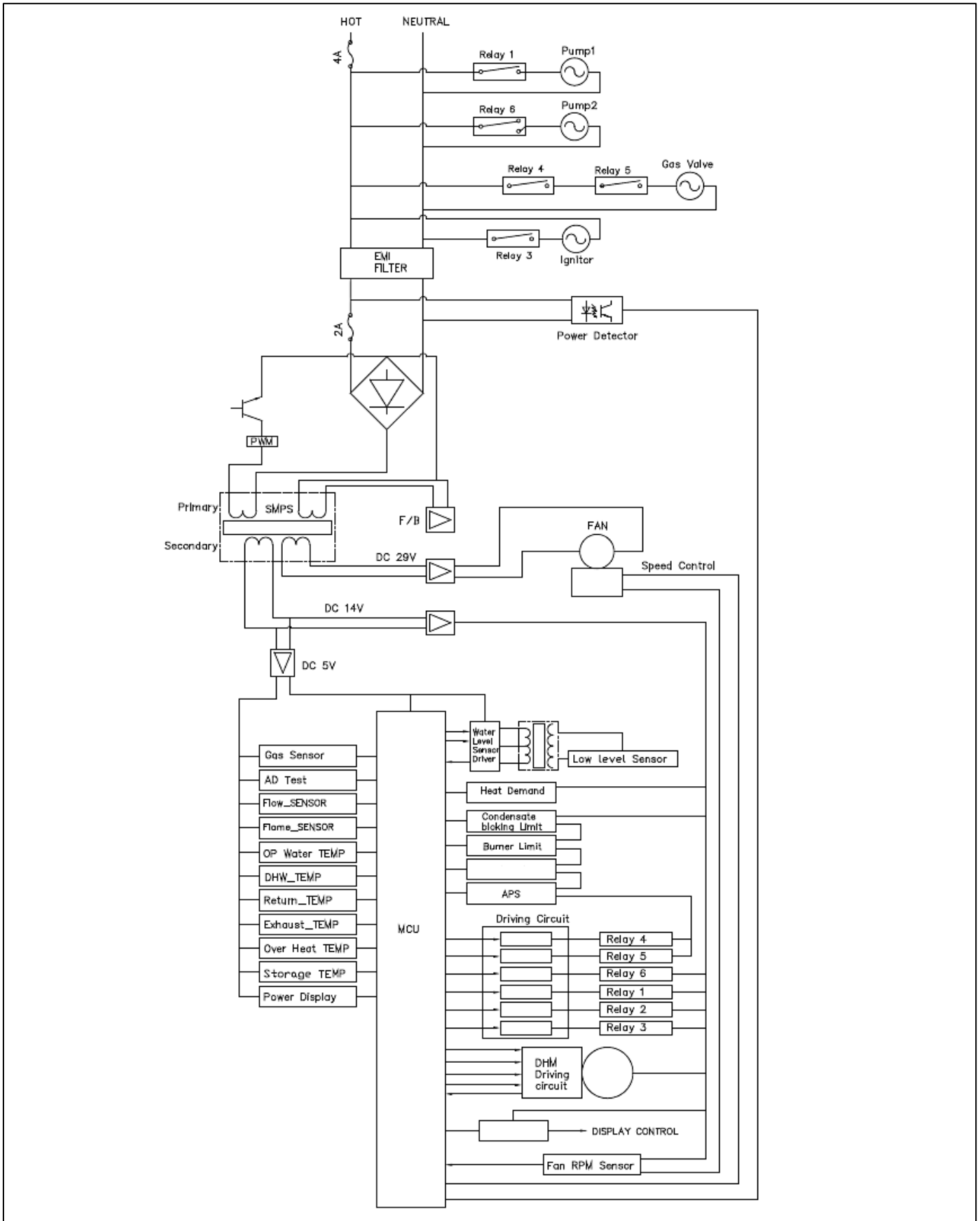

Figure 26 – Ladder Diagram

| CONNECTOR | | | DESCRIPTION | HT SELV |
|--------------------|------|------------|--|-------------------|
| NO. OF LOCATION | PIN | BOARD SILK | | |
| CN9 65001WS-12 | 1 | - | GROUND | HT (120V~) AC |
| | 2 | L | Power Supply Line | |
| | 3 | CP1 | Pump 1: Central Heating Pump | |
| | 4 | IT | Ignitor | |
| | 5 | L(HT) | Pump 2: Recirculation Pump | |
| | 6 | GV | Gas Valve | |
| | 7 | - | - | |
| | 8 | N | Power Supply Neutral | |
| | 9-12 | — N — | AC Power COM Line | |
| CN6 LW6A4-03 | 1 | CP2/3WAY | NOT USED | |
| | 3 | | | |
| CN1 SMW250-05 | 1 | RS-485 | RS485 + | SELV (5V) DC |
| | 2 | | RS485 - | - |
| | 3 | | GND | SELV (5V) DC |
| | 4 | | RS485 + | |
| | 5 | | RS485 - | |
| CN4 LWD1140-06 | 1 | FAN | Unused | - |
| | 2 | | GND | SELV (14V) DC |
| | 3 | | VDD | SELV (14V) DC |
| | 4 | | Fan power (start coil) | SELV (8~26.5V) AC |
| | 5 | | Fan power (end coil) | |
| | 6 | | Fan speed feedback signal | SELV (14V) DC |
| CN8 SMW250-04 | 1 | MCU ISP | GND | SELV (5V) DC |
| | 2 | | ISP / Reset Port | |
| | 3 | | ISP TOOL0 Data Port | |
| | 4 | | VCC | |
| CN11 LWD1140-16 | 1 | HWL | Not Used | SELV (12V~) AC |
| | 8 | | | |
| | 2 | LWL | Low Water Level Leakage Sensor | |
| | 10 | | | |
| | 3 | HD | Central Heating Demand | SELV (5V) DC |
| | 11 | TH | Connect to the Display Control (Thermostat) | SELV (14V) DC |
| | 4 | | | |
| | 12 | APS | Air Pressure Switch | |
| | 5 | EL | Not Used | |
| | 13 | | | |
| | 6 | BL | Burner Limit | |
| | 14 | | | |
| | 7 | HL | Condensate Block | |
| 15 | | | | |
| 8 | | | | |
| 16 | | | | |

Table 18 – Appliance Wiring 1

| CONNECTOR | | | DESCRIPTION | HT SELV |
|-------------------|-----|------------|--|------------|
| NO. OF LOCATION | PIN | BOARD SILK | | |
| CN7 LWD1140-14 | 1 | F.S | Flame Detect Sensor | SELV (5V) |
| | 8 | | | |
| | 2 | OP.S | Operating Water Temperature Sensor | |
| | 9 | | | |
| | 3 | DH.S | DHW Temperature Sensor | |
| | 10 | | | |
| | 4 | I.S | Return Water Temperature Sensor | |
| | 11 | | | |
| | 5 | BG.S | Exhaust Temperature Sensor | |
| | 12 | | | |
| | 6 | ST.S | Storage Temperature Sensor | |
| | 13 | | | |
| | 7 | SP.S | CH Over-Heat Temperature Sensor | |
| | 14 | | | |
| CN14 SMW250-09 | 1 | DHM | GND | SELV (14V) |
| | 2 | | DHM Stepper Motor Position | |
| | 3 | | VDD | |
| | 4 | | DHM Stepper Motor Coil X Phase | |
| | 5 | | DHM Stepper Motor Coil Y Phase | |
| | 6 | | VDD | |
| | 7 | | DHM Stepper Motor Coil / X Phase | |
| | 8 | | DHM Power IWM Stepper Motor Coil / Y Phase | |
| | 9 | | Unused | |
| CN3 SMW250-06 | 4 | FLUX1 | VCC | SELV (5V) |
| | 5 | | Water Flow Sensor | |
| | 6 | | GND | |
| CN5 SMW250-10 | 1 | RPM | Fan RPM Check | - |
| | 2 | | GND | |

Table 19 – Appliance Wiring 2

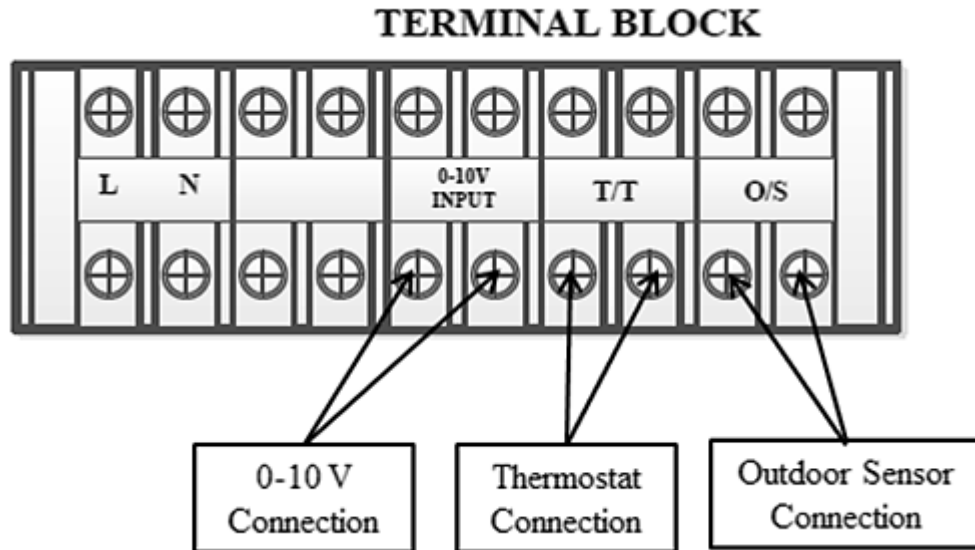

Figure 27 – Terminal Block Wiring Detail

PART 10 – OPERATING SYSTEM INSTRUCTIONS

A. CONTROL PANEL

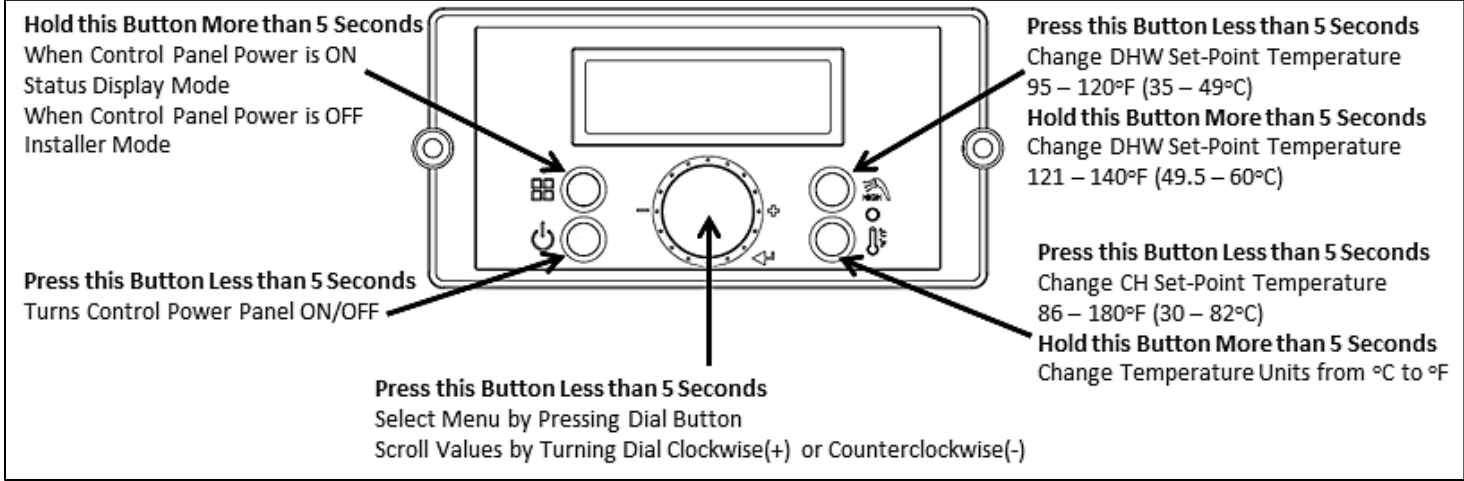

Figure 28 – Appliance Control Panel Detail

B. LCD DISPLAY DESCRIPTIONS

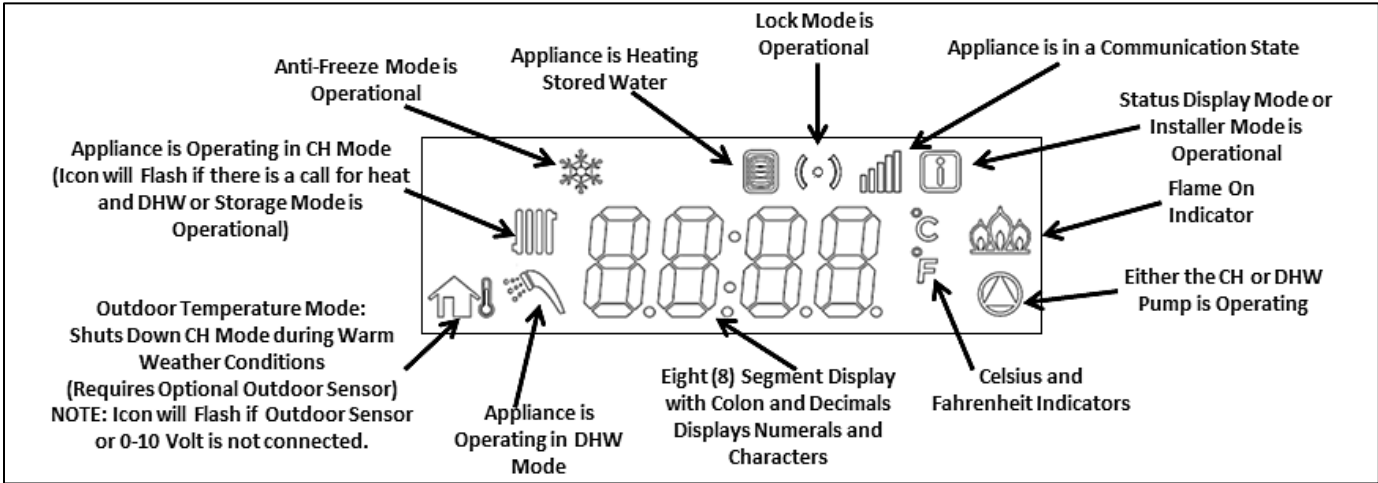

Figure 29 – LCD Display Detail

- LCD also features a backlit lamp that will illuminate:
- When a user action is detected (a button is pressed)
 - The display has timed out for approximately 2 minutes

C. START-UP SEQUENCE

After the appliance is powered ON, the LCD display shows a sequence of information. The icons will flash, followed by various indicators that describe the appliance controller and software versions. It will take the appliance roughly 15 seconds to cycle through the Start-Up Sequence.

After start-up, the display appears as follows.

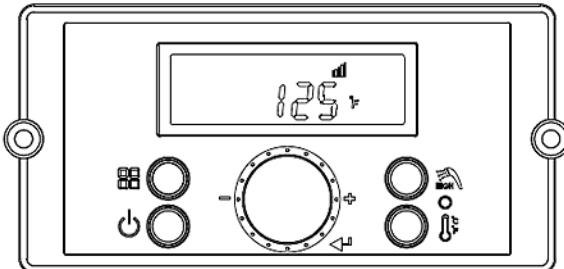



Figure 30 – Initial Display Screen Example

NOTE: The initial display screen will differ depending on a number of factors, including whether the appliance detects a call for heat or hot water.

The Control System can operate through user and service modes that have specific LCD outputs and dedicated controls, including:

- Changing the Set-Point Temperature
- Lock Mode
- Error Mode
- Status Display Mode
- Outdoor Temperature Mode
- Installer Mode

D. CHANGING THE DHW SET-POINT

The display shows the  icon when the DHW set-point can be changed.

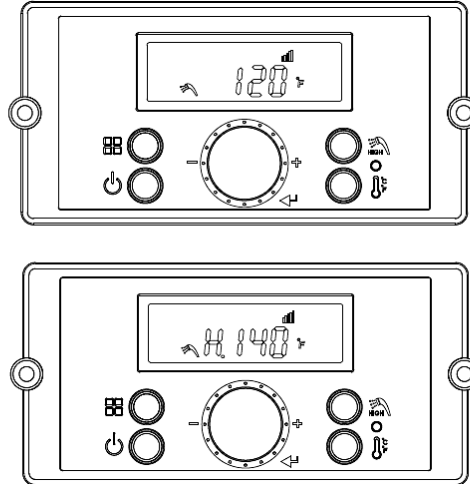







Figure 31 – DHW Set-Point Screens

Press the  button when the display panel is powered ON to change the DHW Set-Point. The DHW icon and current set-point will display and flash. This indicates that the DHW Set-Point can be changed. Factory DHW Set-Point is 125°F (51°C). Initial DHW Set-Point range is 95 – 120°F (35 – 49°C).

Turn the dial  counterclockwise to lower and clockwise to raise the DHW set-point. After changing the temperature, press the  button to save the set-point.

To change the DHW Set-Point above 121°F (49.5°C), press and hold the  button for five seconds when the display panel is powered ON. The current DHW set-point will display. The DHW icon will flash. And the scald warning letter “H” (high temperature) will display. High temperature DHW Set-Point range is 121 – 140°F (49.5 – 60°C).

Turn the dial  counterclockwise to lower and clockwise to raise the DHW set-point. After changing the temperature, press the  button to save the set-point.

DANGER

Hotter water increases the risk of scald injury. Scalding may occur within 5 seconds at a setting of 140°F (60°C). Water temperature over 125°F can instantly cause severe burns, or death, from scalds. Children, disabled, and elderly are at the highest risk of being scalded. See instruction manual before setting temperature at appliance. Feel water before bathing or showering!

E. CHANGING THE TEMPERATURE INDICATOR

To change the temperature indicator from Fahrenheit to Celsius, press and hold the  button for more than five seconds when the display panel is powered ON. This will toggle the temperature unit indicated on the display.

F. CHANGING THE CH SET-POINT

Press the  button when the display panel is powered ON. The display will appear as follows. The set-point will flash when the CH Set-Point can be changed.

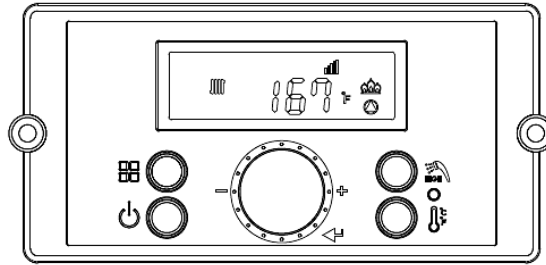



Figure 32 – CH Set-Point Screen

Factory CH Set-Point is 180°F (82°C). CH Set-Point range is 86 – 180°F (30 – 82°C).

Turn the dial  counterclockwise to lower and clockwise to raise the current CH set-point. After changing the temperature, press the  button to save the setting.

G. STORAGE MODE

Storage Mode indicates that the appliance is heating stored water in the internal storage tank. When Storage Mode is operating the display appears as follows.

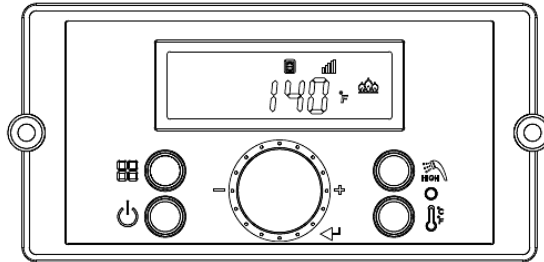



Figure 33 – Storage Mode Screen

H. STATUS DISPLAY MODE

Status Display Mode will activate when the  button is pressed and held for five seconds when the display panel is powered ON.

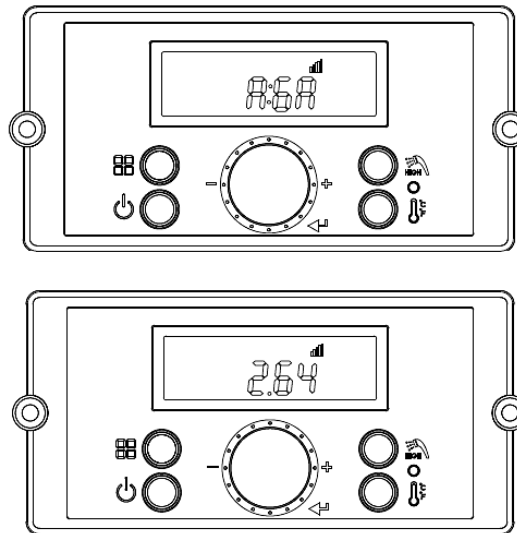











Figure 34 – Status Mode Screens

Turn the dial  counterclockwise and clockwise to scroll through the displayed parameters. To view parameter details, press the  button at the appropriate screen. Press the  or  buttons to leave the parameter.

Press the  button again to return to Operation Mode.

To turn on Lock Mode, press the  button at the d:Lc parameter. Turn the dial  counterclockwise or clockwise to scroll On or Off. Press the  button to save the selection and return to the parameters.

Press the  button again to return to Operation Mode.

NOTE: The Control System will not allow the changes if Lock Mode is activated. Lock Mode will have to be turned off before making further changes.











| Parameter | Detail | | Description | | | |
|-----------------------|---|-----------------------|---|---|---|---|
| O: ot | Outdoor temperature | | Current outdoor sensor temperature | | | |
| A: Li or A: GA | DHW Water flow rate | | Current flow (Li: LPM, GA: GPM) | | | |
| b: It | CH return water temperature | | Current CH return water temperature | | | |
| C: Fr | FAN speed (RPM) | | Current fan speed (RPM) | | | |
| d: Lc | Lock function (Lock) | | Lock Mode "ON"/"OFF" | | | |
| E: oP | CH supply temperature (Operating temperature) | | Current CH supply temperature | | | |
| F: dH | DHW outlet temperature | | Current DHW outlet temperature | | | |
| H: Eh | Exhaust temperature | | Current exhaust temperature | | | |
| I: St | Internal storage tank temperature | | Current stored water temperature | | | |
| Parameter | Detail | | Description | | | |
| J: oH | CH water overheat temperature | | Current temperature on the overheating sensor. | | | |
| L: rt | 1: PH | Burner Operation Time | Supply power time | Unit : 100 hour | | |
| | 2: rh | | Burner operation time | Unit : 1 hour | | |
| | 3: rH | | Burner operation time | Unit : 1,000 hour | | |
| | 4: It | | Ignition cycles | Cycle : 10 times | | |
| | 5: IH | | Ignition cycles | Cycle : 10,000 times | | |
| P: Ou | Displays output condition for Internal recirculation pump, and heating pump.  | | Items | 1st | 2nd | 3rd |
| | | | | Internal DHW Storage pump | Internal CH Primary Pump | Not Used |
| | | | Stop |  |  |  |
| | | Operation |  |  |  | |

Table 20 – Status Mode Display Screen Descriptions

I. INSTALLER MODE

Installer Mode will activate when the  button is pressed and held for five seconds while the display is powered OFF. If the display is powered on, press the  button to turn it off before pressing and holding the  button for five seconds.

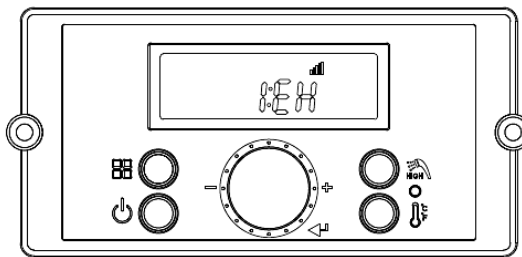







Figure 35 – Installer Mode Screens

Toggle through items that can be viewed/changed by turning the dial . To view/change an item, press the  button. Some displayed items can be changed by turning the dial  counterclockwise to lower and clockwise to raise the displayed value. Press the  button again to save settings.

To leave Installer Mode, press the  button again. The display will return to power off mode.

| Display | Default | Detail | Description |
|--------------|---------|------------------------------|--|
| 1: EH | E0:00 | Error history up to 10 | Check last 10 error codes (E0 - E9) |
| 2: cE | OFF | Delete Error history | Select "ON" to delete error code history Range: ON or OFF |
| 3: In | OFF | Initialized system | Select "ON" to reset to factory setting (Burner operation time, Ignition cycles, and Supply power time will not be reset) Range: ON or OFF |
| 4: Fu | GA | Change unit for water volume | Range: GA or Li |

| Display | Default | Detail | Description |
|---------|---------|---|---|
| 5: St | ON | Stored water heating function "ON", "OFF" | Select "OFF" to turn off this function Range: ON or OFF |
| 6: OH | 68 F | Maximum Outdoor Temperature | When used with an outdoor sensor, sets the maximum outdoor design temperature for the system design. Warm weather shut down will disable the appliance if the programmed outdoor temperature is exceeded. Maximum outdoor temperature must be set 9°F above the minimum outdoor temperature. Range: (Minimum Outdoor Temperature + 9°F) to 110°F |
| 7: OL | 5 F | Minimum Outdoor Temperature | Sets the minimum outdoor design temperature for the system. Minimum outdoor temperature must be set 9°F below the maximum outdoor temperature. Range: -4°F to (Maximum Outdoor Temperature - 9°F) |
| 8: FH | 00 | Maximum Fan speed | Adjusts Maximum Fan Speed Range: -30 - +30 |
| 9: FL | 00 | Minimum Fan speed | Adjusts Minimum Fan Speed Range: -30 -+30 |
| 10: dr | NO | Initialized burner operation time | Select ON to Initialize burner operation time Range: NO or YES |
| 11: dl | NO | Initialized ignition cycle | Select ON to Initialize ignition cycles Range: NO or YES |
| 12: bt | 0 | Boost Function | This function boosts CH temperature to the maximum if set point is not reached within the set period of time. Range: 0 - 120 min |
| 13: Ft | 1 | CH Anti-Frequency time | This function delays burner operation during CH mode Range: 0 - 20 min |
| 14: bo | 27 F | Set differential temperature to turn burner "ON" | When set, the appliance will operate to heat CH water when water temperature falls below a differential setting. Example: If setpoint is 180°F and differential is 27°F, the appliance will turn on when CH water temperature falls below 153°F. Range: 9 - 27°F |
| 15: OF | 68 F | Warm Weather Shutdown | This warm weather temperature setting will shut down CH Mode Range : 50 - 110°F |
| 16: cH | 180 F | Maximum supply temperature | Sets the maximum design supply temperature based on the minimum outdoor design temperature. Maximum supply temperature must be set 9°F above the minimum supply temperature. Range: (Minimum Supply Temperature + 9°F) - 180°F |
| 17: cL | 86 F | Minimum supply temperature | Sets the design supply water temperature based on the maximum outdoor design temperature. Minimum supply temperature must be set 9°F below the maximum supply temperature. Range: 86°F to (Maximum Supply Temperature - 9°F) |
| 18: dH | 140 F | Maximum DHW set temperature | Sets Maximum DHW Setpoint temperature Range:120 - 140°F |
| 19: cb | 100 | Heating capacity | Set Heating combustion rate Range: 50 - 100% |
| 20: db | 100 | DHW capacity | Set DHW combustion rate Range: 50 - 100% |
| 21: PP | 40 | Internal CH Pump Post Run Timer, T/T Calling for Heat | When appliance CH setpoint is satisfied, but T/T is calling for heat, the burner will shut OFF and the CH pump will continue to run for this set amount of time Range: 1 ~ 60 minutes |
| 22: Po | 5 | Internal CH Pump Overrun Timer (On) | This function runs the Internal CH Pump after the Internal CH Pump Post Run Timer has completed. This will cycle the Internal CH Pump again based on the default programmed Off and On cycles and repeats until the central heating call is satisfied. Range: 1~60 minutes |
| 23: PF | 10 | Internal CH Pump Overrun Timer (Off) | |
| 24: SF | 158 F | Internal DHW Storage Tank Setpoint | Sets the Internal DHW Storage Tank Setpoint Range:140 ~ 167°F |
| 25: So | 27 F | Internal DHW Storage Tank Differential | Sets the Internal DHW Storage Tank Differential Range: 9 ~ 36°F |
| 26: dt | 2 | Delay time when switching from DHW mode to CH mode | Range: 0 – 2 minutes |

| Display | Default | | Detail | Description |
|---------|-------------------------|-----|--|---|
| 27:PE | 1 | | Internal CH Pump Post-Purge Time, T/T Satisfied | Allows the user to set the appliance pump post purge time once the appliance CH setpoint and thermostat are satisfied. Range: 1-5 minutes |
| 28: HA | HA 0 | | N/A | N/A |
| 29: AP | AP: cP | 5 | Internal CH Pump and Internal DHW Storage Pump Test Mode | This function sets the time to run both the Internal CH and Internal DHW Storage pumps to purge air from the system. Range: 1 – 30 minutes |
| | cP: off or cP: on | OFF | Internal CH Pump and Internal DHW Storage Pump Test Mode | Turn this function on to activate Internal CH and Internal DHW Storage pump testing. Only works in installation mode. Turns off when in normal mode. |

Table 21 – Installer Mode Descriptions

J. ERROR MODE

The following screen will display when the appliance encounters an error.

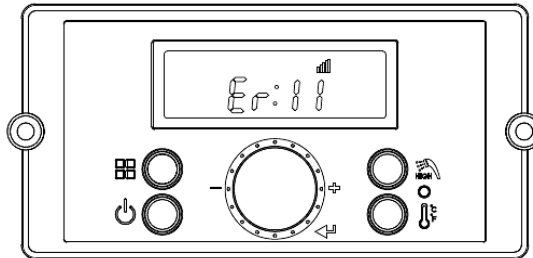

Figure 36 – Error Mode Screen

| Error Code | Error Code Description | Possible Remedies |
|------------|--|---|
| Er:10 | Flame has Extinguished 8 (Eight) Times | Press the Power button to clear the Error Code. If Error happens again: 1. Monitor the gas pressure to the appliance while in operation. Ensure pressure is between 3.5 and 14" WC. 2. Check gas valve wire. Ensure connection is secure. 3. Check flame detection sensor. Ensure connections are secure. Normal operating settings are more than 2.5DC before ignition, less than 2.5DC after ignition. 4. Check vent terminations. Ensure there are no blockages. 5. Assure that the flame is stable when lit. 6. If the problem persists, replace the main control. |
| Er:11 | Ignition has Failed 10 (Ten) Times | Press the Power button to clear the Error Code. If Error happens again: 1. Monitor the gas pressure to the appliance while in operation. Ensure pressure is between 3.5 and 14" WC. 2. Check gas valve wire. Ensure connection is secure. 3. Check flame detection sensor. Ensure connections are secure. Normal operating settings are more than 2.5DC before ignition, less than 2.5DC after ignition. 4. Check igniter transformer for proper connection. 5. Clean the spark igniter with steel wool to remove oxides. Ensure proper separation (3-4 mm). 6. Replace the spark igniter if damaged. 7. Assure that the flame is stable when lit. 8. If the problem persists, replace the main control. |
| Er:16 | Operating Temperature Sensor detects Water Temperature Greater than 203°F (95°C) | Press the Power button to clear the Error Code. If Error happens again: 1. Check if dip switch High Fire setting is ON. Switches 6 and 7 should be OFF for normal operation. 2. Check if CH inlet pipe is blocked. Ensure there is enough water flowing to the appliance. 3. Check Operating Temperature sensor at CH heat exchanger outlet. If resistance is zero, replace the sensor. 4. If the problem persists, replace the main control. |
| Er:20 | Condensate – Closed is Normal, Open is Fault (Condensate Drain Trap) | Press the Power button to clear the Error Code. 1. Check Condensate and main controller connections. Ensure all are secure. 2. Check Condensate sensor resistance. If resistance is zero, replace the switch. 3. Check Condensate hose. Ensure it is connected and in good condition. 4. Check condensate line and termination for blockages. 5. Check exhaust vent for blockages. 6. If the problem persists, replace the main control. |
| Er:28 | Overheat Sensor Open or Short | This Error Code will go away when CH temperature decreases. If Error happens again: 1. Check overheat temperature sensor. Ensure connections are secure. 2. Check overheat sensor resistance. If resistance is zero, replace the sensor. 3. If the problem persists, replace the main control. |

| Error Code | Error Code Description | Possible Remedies |
|------------|--|---|
| Er:29 | APS Open | <ol style="list-style-type: none"> 1. Check APS and connections. 2. If APS is open, replace the switch. 3. If APS is closed and connections are secure, check switch resistance. If resistance is zero, replace the switch. 4. Check condensate line and termination for blockages. 5. Check exhaust vent for blockages. 6. Press the Power button to clear the Error Code and restart appliance. 7. If the problem persists, replace the main control. |
| Er:30 | DHW Storage Temperature Sensor Open or Short | <p>This Error Code will go away when stored DHW temperature decreases.</p> <p>If Error happens again:</p> <ol style="list-style-type: none"> 1. Check DHW storage temperature sensor. Ensure connections are secure. 2. Check DHW storage temperature sensor resistance. If resistance is zero, replace the sensor. 3. If the problem persists, replace the main control. |
| Er:32 | DHW Sensor Open or Short | <p>This Error Code will go away when outlet DHW temperature decreases.</p> <p>If Error happens again:</p> <ol style="list-style-type: none"> 1. Check DHW outlet temperature sensor. Ensure connections are secure. 2. Check sensor resistance. If resistance is zero, replace the sensor. 3. If the problem persists, replace the main control. |
| Er:33 | CH Temperature Sensor Open or Short | <p>This Error Code will go away when CH temperature decreases.</p> <p>If Error happens again:</p> <ol style="list-style-type: none"> 1. Check CH temperature sensor. Ensure connections are secure. 2. Check CH sensor resistance. If resistance is zero, replace the sensor. 3. If the problem persists, replace the main control. |
| Er:35 | Exhaust Sensor Open or Short | <p>This Error Code will go away when exhaust temperature decreases.</p> <p>If Error happens again:</p> <ol style="list-style-type: none"> 1. Check exhaust temperature sensor. Ensure connections are secure. 2. Check sensor resistance. If resistance is zero, replace the sensor. 3. Check exhaust vent for blockage. 4. If the problem persists, replace the main control. |
| Er:36 | Abnormal Supply Voltage | <p>Supply voltage is too low to operate. This Error Code will go away when supply voltage returns to normal operating range.</p> <p>If Error happens again:</p> <ol style="list-style-type: none"> 1. Ensure appliance is properly wired to a power source meeting the requirements on the rating plate. 2. If problem persists, replace the main control. |
| Er:37 | Abnormal Supply Frequency | <p>Supply frequency is too high to operate. This Error Code will go away when supply frequency returns to normal operating range.</p> <p>If Error happens again:</p> <ol style="list-style-type: none"> 1. Ensure appliance is properly wired to a power source meeting the requirements on the rating plate. 2. If problem persists, replace the main control. |
| Er:38 | Error Appears When Control Stores Data, but Data is not Saved | <p>Press the Power button to clear the Error Code.</p> <p>Replace the main control.</p> |
| Er:40 | Gas Leakage is Detected for Greater than 5 seconds, or three times within 10 minutes | <p>IMPORTANT: If you smell gas, STOP! Follow the instructions on page 2, this manual, and call a qualified service technician or the fuel gas utility.</p> <p>Press the Power button to clear the Error Code.</p> <p>If Error happens again:</p> <ol style="list-style-type: none"> 1. Check the appliance cover. Ensure it is secure. 2. Check gas connections for leakage with a soapy solution. Fix any leaks. 3. Check condition of the burner assembly. 4. If the problem persists, replace the main control. |
| Er:41 | Fan Speed too High with Flame On | <p>Press the Power button to clear the Error Code.</p> <p>If Error happens again:</p> <ol style="list-style-type: none"> 1. Check the vent connections for blockages. 2. Check the burner assembly. 3. Check fan operation. If fan appears to be operating normally but RPMs are too high, replace the fan. 4. If the problem persists, replace the main control. |
| Er:42 | Jumped Wire Disconnected | <p>Press the Power button to clear the Error Code.</p> <p>If Error happens again:</p> <ol style="list-style-type: none"> 1. Ensure the jumped wire is properly connected. 2. If the problem persists, replace the main control. |
| Er:43 | Burner Overheat Switch Open | <p>Press the Power button to clear the Error Code.</p> <p>If Error happens again:</p> <ol style="list-style-type: none"> 1. Check burner overheat switch connections. Ensure connections are secure. 2. Check switch resistance. If resistance is zero, replace the switch. 3. If the problem persists, replace the main control. |
| | | |

| Error Code | Error Code Description | Possible Remedies |
|------------|---|--|
| Er:61 | Fan Speed Feedback Signal Abnormal | This Error Code will go away when the condition is remedied. If Error happens again: 1. Check the connections to the fan. Ensure all are secure. 2. If the fan does not rotate during the ignition sequence, check for AC8V~26.5V power at the fan connection. If AC8V~26.5V power is present at the control, replace the fan. If the blower does not have AC8V~26.5V power, check power at the control. If AC8V~26.5V power is not present at the control, replace the control. 3. If the problem persists, replace the main control. |
| Er:66 | Mixing Valve Initial Value Error (Mixing Valve Cannot Return to Initial Position) | This Error Code will go away when the condition is remedied. If Error happens again: 1. Turn power OFF and ON at the main power switch internal to the appliance. 2. Check wiring connections to mixing valve. Ensure all are secure. 3. Replace mixing valve. 4. If the problem persists, replace the main control. |
| Er:68 | Mixing Valve Operation Error (Mixing Valve Stuck in Initial Position) | This Error Code will go away when the condition is remedied. If Error happens again: 1. Turn power OFF and ON at the main power switch internal to the appliance. 2. Check wiring connections to mixing valve. Ensure all are secure. 3. Replace mixing valve. 4. If the problem persists, replace the main control. |
| Er:70 | Register, Ram, Rom, I/O Port, AD Abnormal, Important EPROM Data or Safe Data Abnormal | This Error Code will go away when the condition is remedied. If Error happens again: 1. Turn power OFF and ON at the main power switch internal to the appliance. 2. If the problem persists, replace the main control. |
| Er:72 | Flame Signal Detected before Ignition | This Error Code will go away when the condition is remedied. If Error happens again: 1. Check the appliance cover. Ensure it is secure. Flame detection sensor can detect an external light source. 2. Check flame detection sensor. Ensure connections are secure. Normal operating settings are more than 2.5DC before ignition, less than 2.5DC after ignition. 3. If the problem persists, replace the main control. |
| Er:76 | Poor Communication | This Error Code will go away when the condition is remedied. If Error happens again: 1. Check connections from main control to display panel. 2. If the problem persists, replace the display and/or the main control. |
| Er:80 | Low Water Level Sensor (Low Water Level Detected Four (4) Consecutive times) | This Error Code will go away when the condition is remedied. If Error happens again: 1. Ensure all valves are open to the appliance and there are no leaks. 2. Ensure all air has been purged from the system. 3. Check wiring connections to low water level sensor. Ensure all are secure. 4. Check low water level sensor resistance. If resistance is zero, replace the sensor. 5. If the problem persists, replace the main control. |
| Er:81 | Low Water Level Circuit | This Error Code will go away when the condition is remedied. If Error happens again: 1. Ensure all valves are open to the appliance and there are no leaks. 2. Check wiring connections to low water level sensor. Ensure all are secure. 3. Check low water level sensor resistance. If resistance is zero, replace the sensor. 4. If the problem persists, replace the main control. |
| Er:85 | Freeze Protection (Appliance has detected water temperature below 34°F (1°C)) | This Error Code will go away when the freezing condition is remedied. If Error happens again: 1. Ensure appliance is located in a mechanical room protected from freezing conditions. 2. Ensure all valves are open to the appliance, there are no leaks. 3. Check wiring connections to low water level sensor. Ensure all are secure. 4. Check low water level sensor resistance. If resistance is zero, replace the sensor. 5. If the problem persists, replace the main control. |
| Er:94 | Exhaust Sensor detects Vent Temperature is Greater than 190°F (88°C) | This Error Code will go away when the condition is remedied. If Error happens again: 1. Check if dip switch High Fire setting is ON. Switches 6 and 7 should be OFF for normal operation. 2. Check exhaust temperature sensor. Ensure connections are secure. 3. Check sensor resistance. If resistance is zero, replace the sensor. 4. Check exhaust vent for blockage. 5. If the problem persists, replace the control. 6. If the problem persists, replace the heat exchanger. |

Table 22 – Error Codes with Linked Components, Effects, and Actions

K. ERROR TREE ANALYSIS

1. FLAME DETECTION

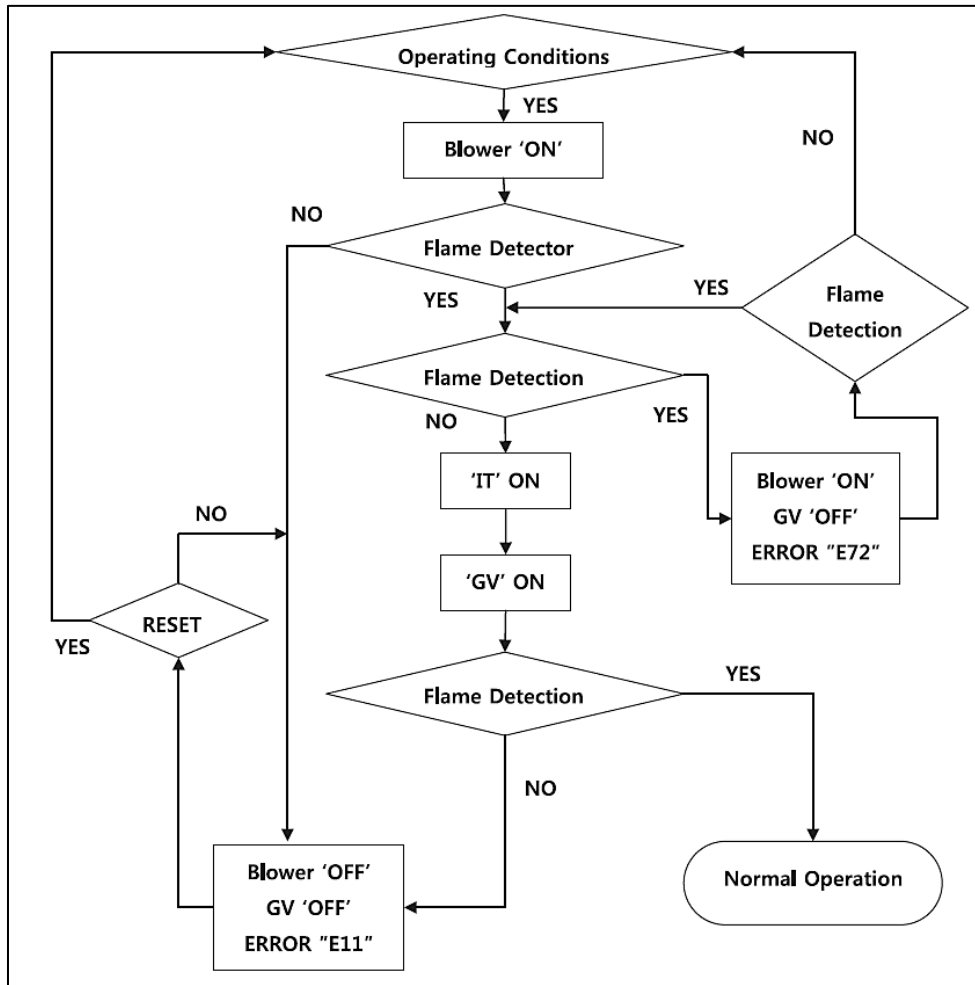

Figure 37 – Flame Detection Error Analysis Tree

2. GAS DETECTION

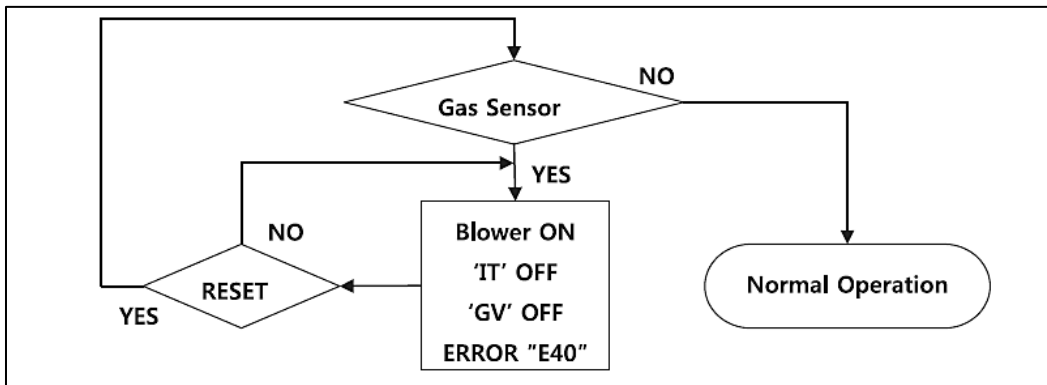

Figure 38 – Gas Detection Error Analysis Tree

3. APS / BURNER OVERHEAT LIMIT / CONDENSATE BLOCK SWITCH

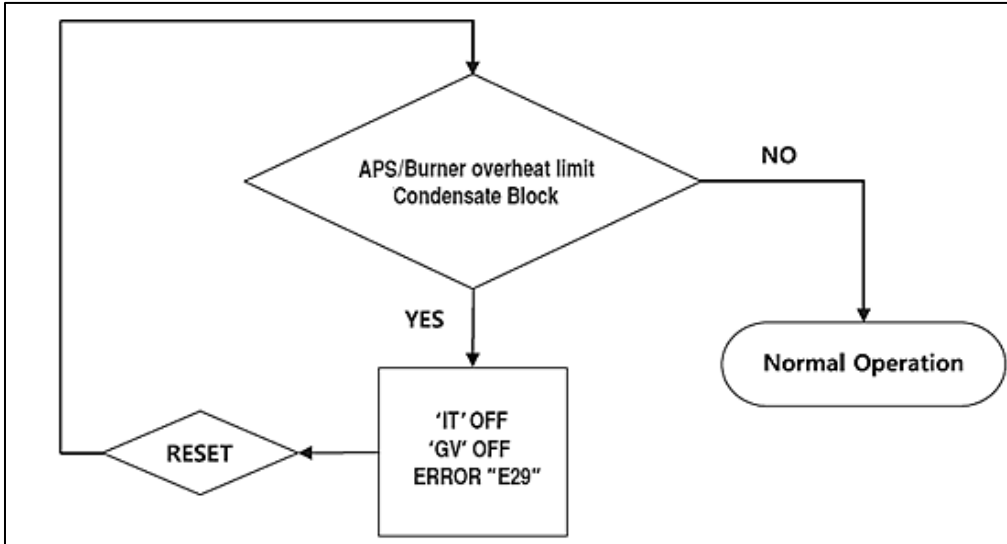

Figure 39 – APS / Burner Overheat Limit / Condensate Block Switch Error Analysis Tree

4. STORAGE / DHW / OP / CH OVERHEAT / EXHAUST OVERHEAT SENSORS

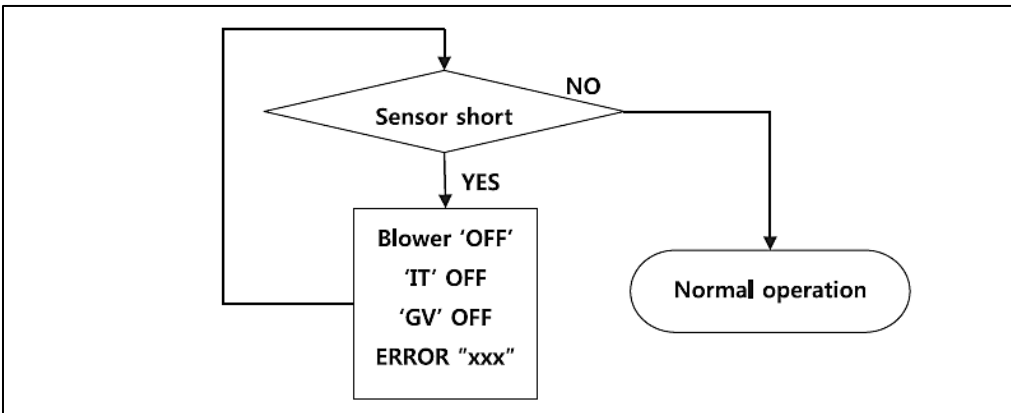

Figure 40 – Storage / DHW / OP / CH Overheat / Exhaust Overheat Sensors Error Analysis Tree

L. OUTDOOR TEMPERATURE MODE (OPTIONAL)

NOTE: If the system requires a fixed operating temperature, the outdoor sensor is not required and should not be installed.

There is no connection required if an outdoor sensor is not used in the installation.

1. Use a minimum 22 AWG wire for runs of 100 feet or less and minimum 18 AWG wire for runs of up to 150 feet.
2. Mount the outdoor sensor on an exterior surface of the building, preferably on the north side in an area that will not be affected by direct sunlight and will be exposed to varying weather conditions.

NOTE: For correct mounting procedures, follow instructions provided with the sensor.

NOTE: If sensor wires are located in an area with sources of potential electromagnetic interference (EMI), the sensor wires should be shielded, or the wires routed in a grounded metal conduit. If using shielded cable, the shielding should be connected to the common ground of the appliance.

NOTE: Outdoor Temperature Mode Icon on the display will flash if an Outdoor Sensor or 0-10 Volt is not connected to the appliance.

See Figure 41 to set your Outdoor Reset Curve.

To check the CH Target Temperature while using Outdoor Temperature Mode, press the  button while the appliance is operational and the display panel is powered on.

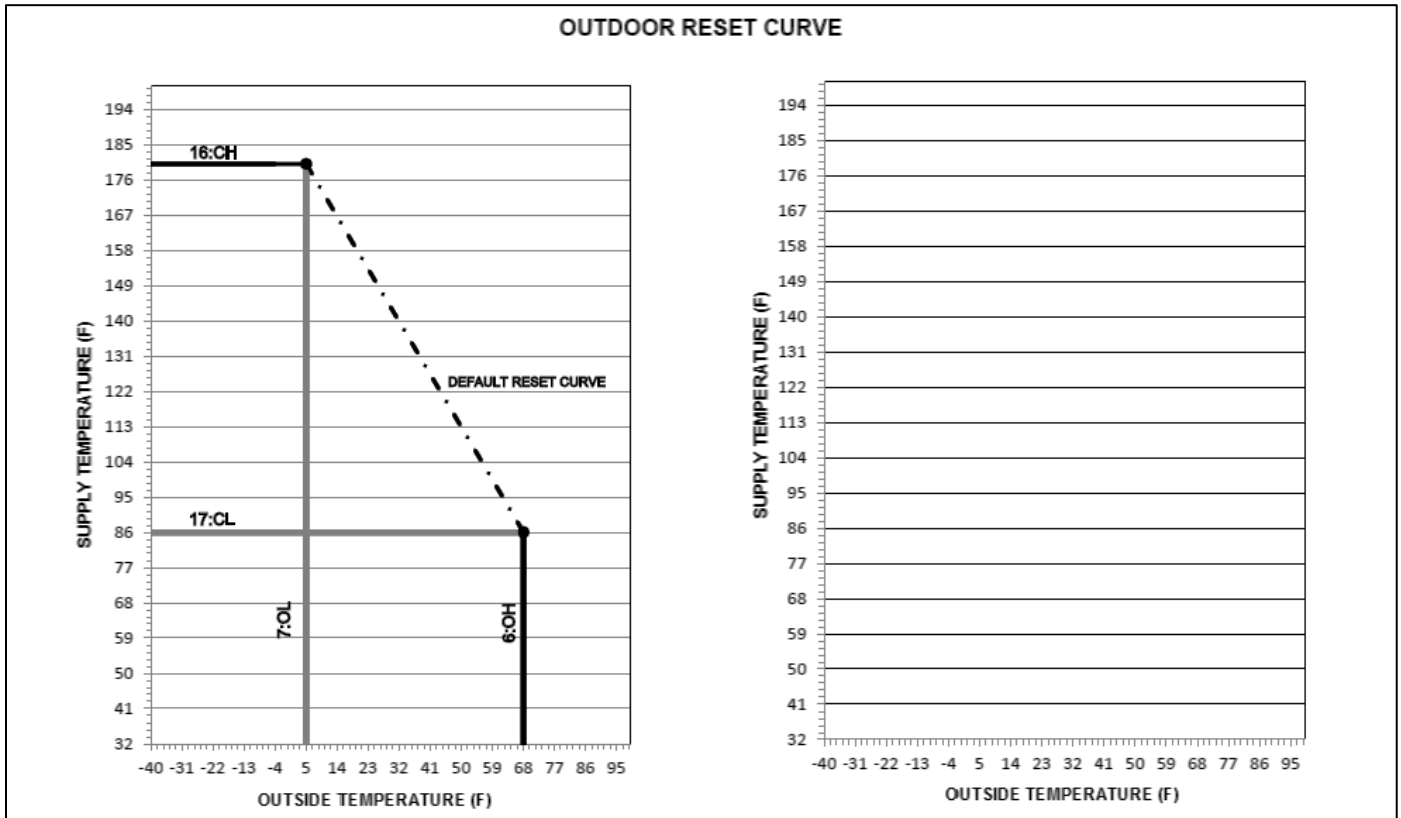

Figure 41 – Outdoor Reset Curve – See Installer Mode for Curve Setting Descriptions

M. 0-10 VOLT INPUT

1. A signal from a building management system may be connected to the appliance to enable remote control. This signal should be a 0-10 volt positive-going DC signal. When this input is enabled, a building control system can be used to control the set point temperature of the appliance. The control interprets the 0-10 volt signal as follows; when the signal is between 0 and 1.5 volts, the appliance will be in standby mode, not firing. When the signal rises above 1.5 volts, the appliance will ignite. As the signal continues to rise towards its maximum of 10 volts, the appliance will increase in set point temperature.

2. Connect a building management system or other auxiliary control signal to the terminals marked for this purpose on the appliance terminal block (shown in Piping Diagrams, this manual). Caution should be used to ensure that the 0-10 VOLT + connection does not become connected to ground.

NOTE: Ensure that the polarity of the connections from the external modulating appliance controller to the appliance is correct. Reversed polarity could lead to erratic and/or no response from the appliance controller.

NOTE: Outdoor Temperature Mode Icon on the display will flash if an Outdoor Sensor or 0-10 Volt is not connected to the appliance.

PART 11 – START-UP PREPARATION

WARNING

Thoroughly clean and flush any system that has used glycol before installing the appliance.

A. CHECK / CONTROL WATER CHEMISTRY

CAUTION

Chemical imbalance of your water can cause severe damage to your appliance and associated equipment, and may also affect efficiency. You may have to have your water quality professionally analyzed to determine whether you need to install a water softener. It is important that the water chemistry on both the domestic hot water and central heating sides are checked before installing the appliance, as water quality will affect the reliability of the system. Outlined below are those water quality parameters which need to be met in order for the system to operate efficiently for many years. **Failure of a heat exchanger due to lime scale build-up on the heating surface, low pH or other imbalance IS NOT covered by the warranty.**

To assure good extended service life, it is recommended that you test your water quality prior to installation. Listed below are some guidelines.

WARNING

Do not use petroleum-based cleaning or sealing compounds in the appliance system. Damage to elastomer seals and gaskets in the system could occur, resulting in substantial property damage.

Water Quality

Potable water is defined as drinkable water supplied from utility or well water in compliance with EPA secondary maximum contaminant levels (40 CFR Part 143.3) as shown in Table 23. It is important to ensure the water quality is within these determined limits. If your water contains contaminants higher than outlined by EPA, then water treatment is recommended and additional maintenance may be required. If you suspect that your water is contaminated in any way, discontinue use of the appliance and contact an authorized technician or licensed professional.

| Contaminant | Maximum Allowable Level | Contaminant | Maximum Allowable Level |
|----------------|-----------------------------|------------------------------|-------------------------|
| Total Hardness | 200 mg/l (12 grains/gallon) | Manganese | 0.05 mg/l |
| Aluminum | 0.05 to 0.2 mg/l | pH | 6.5-8.5 |
| Chloride | 250 mg/l | Sulfate | 205 mg/l |
| Copper | 1 mg/l | Total Dissolved Solids (TDS) | 500 mg/l |
| Iron | 0.3 mg/l | Zinc | 205 mg/l |

Table 23 – Water Quality Specifications

Clean system to remove sediment*

1. You must thoroughly flush the system (without the appliance connected) to remove sediment. The high-efficiency heat exchanger can be damaged by buildup or corrosion due to sediment.
2. For zoned systems, flush each zone separately through a purge valve. (If purge valves and isolation valves are not already installed, install them to properly clean the system.)
3. Flush system until water runs clean and you are sure piping is free of sediment.

*NOTE: It is recommended you clean heat exchanger at least once a year to prevent lime scale buildup. Follow the maintenance procedure to clean the heat exchanger in this manual.

NOTE: APPLIANCE FAILURE DUE TO IMPROPER WATER CHEMISTRY IS NOT COVERED BY WARRANTY.

B. CHECK FOR GAS LEAKS

WARNING

Before starting the appliance, and during initial operation, smell near the floor and around the appliance for gas odorant or any unusual odor. Remove appliance front door and smell interior of appliance enclosure. Do not proceed with startup if there is any indication of a gas leak. Repair any leaks at once.

WARNING

PROPANE APPLIANCES ONLY – Propane suppliers mix an odorant with the gas to make its presence detectable. In some instances, the odorant can fade, and the gas may no longer have an odor. Before startup and periodically thereafter, have the propane supplier verify the correct odorant level in the gas.

WARNING

FOR YOUR OWN SAFETY READ BEFORE OPERATING

1. This appliance does not have pilot. It is equipped with an ignition device which automatically lights the burner. Do not try to light the burner by hand.

2. BEFORE OPERATING: smell all around the appliance area for gas. Be sure to smell next to the floor because some gas is heavier than air and will settle on the floor.

WHAT TO DO IF YOU SMELL GAS

- Do not try to light any appliance.
- Do not touch any electric switch; do not use any phone in your building.
- Immediately call your gas supplier from a neighbor's phone. Follow the gas suppliers' instructions.
- If you cannot reach your gas supplier, call the fire department.
- Turn off gas shutoff valve (located outside of the appliance) so that the handle is crosswise to the gas pipe. If the handle will not turn by hand, don't try to force or repair it, call a qualified service technician. Force or attempted repair may result in a fire or explosion.

4. Do not use this appliance if any part has been under water. Immediately call a qualified service technician to inspect the appliance and to replace any part of the control system and any gas control that has been damaged.

5. The appliance shall be installed so the gas ignition system components are protected from water (dripping, spraying, rain, etc.) during appliance operation and service (circulator replacement, condensate trap, control replacement, etc.)

Failure to follow these instructions could result in property damage, serious personal injury, or death.

WARNING

If you discover any evidence of a gas leak, shut down the appliance at once. Find the leak source with a bubble test and repair immediately. Do not start the appliance again until the leak is repaired. Failure to comply could result in substantial property damage, severe personal injury, or death.

C. FILL AND TEST WATER SYSTEM

WARNING

Ensure the appliance is full of water before firing the burner. Failure to do so will damage the appliance. Such damage IS NOT covered by warranty, and could result in property damage, severe personal injury, or death.

1. Fill the system only after ensuring water chemistry meets the requirements listed in this manual.
2. Close the manual and automatic air vents and appliance drain valve.
3. Fill to the correct system pressure. Correct pressure will vary with each application.
 - a. Typical cold water fill pressure for a CH residential system is 12 psi.
 - b. Pressure will rise when appliance is turned on and system water temperature increases. Operating pressure of the CH system should never exceed 25 psi, and must never exceed the relief valve pressure setting.
4. At initial fill and during appliance startup and testing, check system thoroughly for leaks. Repair all leaks before proceeding further.

WARNING

Eliminate all system leaks. Continual fresh make-up water will reduce appliance life. Minerals can build up in the heat exchanger, reducing heat transfer, overheating the heat exchanger, causing heat exchanger failure and possibly resulting in property damage, severe personal injury, or death.

5. The system may have residual substances that could affect water chemistry. After the system has been filled and leak tested, verify that water pH and chlorine concentrations are acceptable by sample testing.











CAUTION

It is important to purge the system of air to avoid damage to the appliance.

D. PURGE AIR FROM CH AND INTERNAL STORAGE TANK**CAUTION**

IMPORTANT! While commissioning the system, the air vent on top of the appliance must remain fully open to allow the appliance to properly fill. Failure to keep the air vent open could lead to improper appliance and system operation.

To purge air from the system:

- a. Connect a hose to the purge valve and route hose to an area where water can drain and be seen.
- b. Close the appliance or system isolation valve between the purge valve and fill connection to the system.
- c. Close zone isolation valves.
- d. Open quick-fill valve on cold water make-up line.
- e. Open purge valve.
- f. Open the isolation valves one zone at a time. Allow water to run through the zone, pushing out the air. Run water until no noticeable air flow is present. Close the zone isolation valves and proceed with the next zone. Follow this procedure until all zones are purged.
- g. Close the quick-fill water valve and purge valve and remove the hose. Open all isolation valves. Watch the system pressure rise to correct cold-fill pressure. It is recommended that you put the pumps into manual operation to assist in purging the circuits.
- h. Disconnect the wires that are connected to the THERMOSTAT terminals of the terminal block. Apply power to the appliance. After the control goes through the start-up sequence, the display will turn off.
- i. Press and hold the  button for five seconds. Then scroll to 29:AP by turning the dial . Press the  button. AP:cP will show on the display. Press the  button to change the test time. The default is five minutes. Turn the dial  counterclockwise to lower or clockwise to raise the displayed value. Press the  button again to save any changes.
- j. Then use the dial  to scroll to cP:off. Press the  button to turn on test mode. Turn the dial  counterclockwise to lower or clockwise to select on. Press the  button again to start test mode.
- k. The CH and internal circulation pumps will come on. Run pumps as required to help bleed out all entrapped air. Some good indicators that air is removed include the absence of gurgling noises in the pipes and pump operation becoming very quiet. Test mode will stop automatically after the set time (default is five minutes), or press the  button to leave it manually.
- l. After the system has operated for some time, eliminate any residual air by using the manual air vents located throughout the system.
- m. If purge valves are not installed in the system, open manual air vents in the system one at a time, beginning with the lowest floor. Close vent when water squirts out. Repeat with remaining vents.
- n. Refill to correct pressure.

E. PURGE AIR FROM DHW SYSTEM

1. Make sure CH and DHW lines to the appliance are open and full of water. Turn on all electric power to appliance.

WARNING

Ensure the appliance is full of water before firing the burner. Failure to do so will damage the appliance. Such damage IS NOT covered by warranty, and could result in property damage, serious personal injury, or death.

2. Open hot water faucets in the DHW system. Start with the faucets nearest the appliance.
3. Keep faucets open until water runs freely and all air is purged. Then move on to faucets further away from the appliance in the system.
4. When water flows freely from all hot water faucets, DHW purging is complete.

F. CHECK THERMOSTAT CIRCUIT(S)

1. Disconnect the two external wires connected to the appliance thermostat terminals (low voltage terminal strip).
2. Connect a voltmeter across these two incoming wires with power supplied to the thermostat circuits. Close each thermostat, zone valve and relay in the external circuit one at a time and check the voltmeter reading across the incoming wires.
3. There should NEVER be a voltage reading.
4. If a voltage reading does occur under any condition, check and correct the external wiring. (This is a common problem when using 3-wire zone valves.)
5. Once the external thermostat circuit wiring is checked and corrected if necessary, reconnect the external thermostat circuit wires to the appliance low voltage terminal strip. Allow the appliance to cycle.

G. CONDENSATE REMOVAL

1. This is a high efficiency condensing appliance. Therefore, the appliance has a condensate drain. Condensate fluid is nothing more than water derived from combustion products, similar to that produced by an automobile when it is initially started.

Condensate is slightly acidic (typically with a pH of 3 to 5) and must be piped with the correct materials. Never pipe the condensate using steel, copper, brass or other materials that will be subject to corrosion. Plastic PVC or CPVC pipe are the only approved materials.

A condensate neutralizer, if required by local authorities, may be purchased from Westinghouse (7450P-212).

2. The appliance is provided with a $\frac{1}{2}$ " X $\frac{3}{4}$ " reducing coupling that must be installed on the appliance before the condensate is piped to a local drain. It is very important that the minimum $\frac{3}{4}$ " condensate line is sloped downward away from the appliance to a suitable inside drain. If the condensate outlet on the appliance is lower than the drain, you must use a condensate removal pump, available from Westinghouse (554200). This pump is equipped with two leads that can be connected to an alarm or another type of warning device to alert the user of a condensate overflow, which, if not corrected, could cause property damage.

3. If a long horizontal run is used, it may be necessary to create a vent in the horizontal run to prevent a vacuum lock in the condensate line.

4. Do not expose the condensate to freezing temperatures.

5. It is very important you support the condensate line to assure proper drainage.

H. FINAL CHECKS BEFORE STARTING APPLIANCE

1. Verify the appliance and system are full of water and all system components are correctly set for operation.

2. Fill the condensate trap with water.

3. Verify electrical connections are correct and securely attached.

4. Inspect exhaust vent and intake piping for signs of deterioration from corrosion, physical damage, or sagging. Verify exhaust vent and intake piping are intact and correctly installed per Venting Section (this manual) and local codes.

I. ADJUSTING GAS PRESSURE AT THE APPLIANCE

NOTE: Refer to Figure 42 when adjusting gas pressure. Loosen the screw before checking the gas inlet pressure.

1. The appliance and its individual shutoff valve must be disconnected from the gas supply piping system during any pressure testing of the system at test pressures greater than $\frac{1}{2}$ psi (3.5 kPa).

2. The appliance must be isolated from the gas supply piping system by closing its individual manual shutoff valve during any pressure testing of the gas supply piping system at test pressures equal to or less than $\frac{1}{2}$ psi (3.5 kPa).

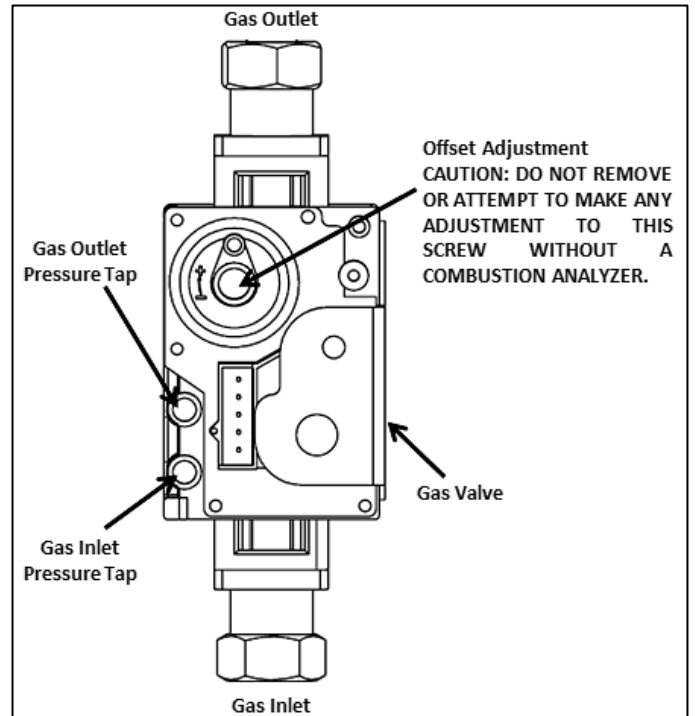

Figure 42 –Gas Valve Detail

NOTICE

Do not fire (operate) the appliance until all connections have been completed and the heat exchanger is filled with water. Doing so will damage the appliance and void the warranty.

ADJUSTING GAS PRESSURE AT THE APPLIANCE

1. Open the gas line and water valves.

2. Use a Phillips Head screwdriver to remove the appliance top cover. Remove the front cover.

3. Loosen the gas inlet pressure tap screw three turns with a screwdriver. Connect the manometer to the inlet gas pressure port. See Figure 42.

4. Turn on power to the appliance and open a hot water faucet.

5. The minimum and maximum inlet gas line pressures must meet the requirements shown in Table 24.

| LP GAS | | NATURAL GAS | |
|------------------|---------|------------------|---------|
| Minimum Pressure | 3.5" WC | Minimum Pressure | 3.5" WC |
| Maximum Pressure | 14" WC | Maximum Pressure | 14" WC |

Table 24 – Gas Pressure Requirements

6. Remove the manometer. Close the screw on the gas inlet pressure tap.

J. SETTING AND VERIFYING THE COMBUSTION SETTING

1. After the appliance has fired, flip DIP switch seven (7) to the ON position (low fire). Proceed to check appliance combustion values.

NOTE: Use a combustion analyzer to ensure CO and CO₂ values are within the range shown in Table 24.

⚠ WARNING

It is required to use a combustion analyzer to verify final adjustment according to the combustion chart (Table 3). Failure to do so could result in serious personal injury or death.

If the readings obtained are lower or higher than the combustion readings in Table 25, use a 4mm Allen key to adjust the offset screw in a clockwise (positive) or counterclockwise (negative) direction (approximately 1/4 turn). See Figure 43. Check your combustion values. Repeat this procedure until the values obtained on the combustion analyzer agree with those stated in Table 25.

NOTE: If the appliance makes a whistling sound (harmonics) at low fire, adjust the offset screw in a clockwise (positive) direction (approximately 1/8 turn). Check your combustion values and ensure they agree with those stated in Table 25 before proceeding.

⚠ WARNING

It is very important that this conversion be set within the recommended CO measurements listed in Table 25. Visually looking at the burner does not determine combustion quality. Failure to measure combustion with a Combustion Analyzer and set the throttle within the recommended CO measurements could result in property damage, severe personal injury, or death.

| COMBUSTION SETTINGS | | | | |
|---------------------|-------------|------------|--------|------------|
| | NATURAL GAS | | LP GAS | |
| FAN SPEED | LOW | HIGH | LOW | HIGH |
| CO PPM | ≤175 | ≤175 | ≤175 | ≤175 |
| CO ₂ (%) | 8 - 10 | 8 ½ - 10 ½ | 9 – 10 | 9 ½ - 10 ½ |

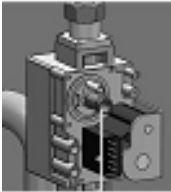

Offset Screw

Figure 43 – Gas Valve Offset Screw

Table 25 – Combustion Settings

2. When low fire settings have been obtained, flip DIP switch seven (7) to its original (OFF) position. This will return the appliance to normal mode.
3. Flip DIP switch six (6) to ON (high fire). Again check combustion readings with a combustion analyzer.
4. When complete, flip DIP switch six (6) to its original (OFF) position. This will return the appliance to normal mode.
5. Allow appliance to operate normally. Ensure it is operating properly.
6. Reinstall the appliance front cover.
7. Use a Phillips Head screwdriver to reinstall the appliance top cover.

PART 12 –INSTALLATION AND START-UP CHECKLIST

| LIGHT OFF ACTIVITIES | | DATE COMPLETED | |
|--|--|----------------|----|
| | | YES | NO |
| 1) Fill the Heating System with Water | Has the system been cleaned and flushed? | | |
| | Does water chemistry meet requirements? | | |
| | If water chemistry does not meet requirements, have treatment measures been put in place? | | |
| | Check all water piping and connections. Are all leak free and properly supported? | | |
| 2) Exhaust Vent and Intake Piping | Has the CH system been pressure tested and pressurized to 12 – 25 psi? Has the DHW system been | | |
| | Has the appliance been vented in accordance with the methods and materials listed in this manual and to meet local codes (vented in approved materials, air supply sufficient for proper operation, combined vent length within the maximum vent length restriction, vent lengths minimized, installed with proper terminations, clearances, and pitch, etc.?) | | |
| | Is vent piping properly supported? | | |
| | Has exhaust vent piping been checked for leaks? | | |
| 3) Condensate Piping / Tubing and Components | Have the exhaust vent and intake pipes been properly installed into the connectors provided on the appliance? | | |
| | Have all condensate line components included with the appliance been installed? | | |
| | Is the condensate line piped with the approved materials listed in this manual? | | |
| | Has the condensate line been routed to a laundry tub or other drain? | | |
| 4) Gas Piping | If necessary, has a condensate pump and/or neutralizer been installed? | | |
| | Has the gas supply line been piped in accordance with the methods listed in this manual (supply line no less than ½” in diameter, length and diameter adequate to deliver the required BTUs, union and shut-off valve installed, etc.)? | | |
| | Does the gas type match the type indicated on the appliance rating plate? | | |
| | Has gas supply line pressure been measured (between 3.5 and 14” WC)? | | |
| 5) Pressure Relief Valves | Has the gas supply line been leak tested per locally approved methods? | | |
| | Have you installed approved pressure relief valves on the appliance? | | |
| | Is the pressure relief valve in the CH line at least 1” in diameter and rated to 30 psi? | | |
| 6) Wire the Appliance | Is the pressure relief valve in the DHW line at least ¾” in diameter and rated to 150 psi? | | |
| | Have you connected the power and control wiring per appliance wiring diagram, this manual? | | |
| | Have all DIP switches been set on the main appliance board? | | |
| | Is electrical connection polarity within appliance requirements? | | |
| 7) Start-Up, Adjust, and Test | Do power specifications meet appliance requirements? 120V AC? | | |
| | If necessary, has the appliance been converted to operate on the proper fuel type? | | |
| | Has the appliance been started? | | |
| | Has CO2 and CO been checked to ensure proper combustion? | | |
| | If necessary, has the appliance gas valve been adjusted to achieve proper combustion? | | |
| | Has the installation been customized per location requirements? | | |
| | Have all customized system parameters been tested? | | |
| | Has proper appliance operation been confirmed? | | |
| Has the burner flame been checked? Is the burner flame a proper blue color? See Figure 44 for flame sight glass window location. | | | |
| If the flame does not appear normal, the combustion system may need to be cleaned or adjusted by a qualified service technician. | | | |
| FINAL INSTALLATION APPROVALS | SIGNED BY TECHNICIAN | DATE | |
| | | | |

Table 26 – Final Installation Checklist

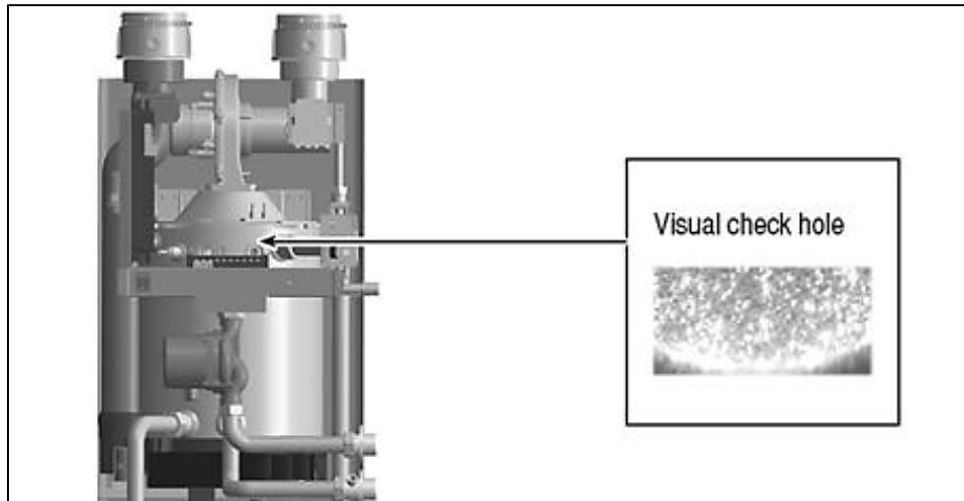

Figure 44 – Flame Sight Glass

PART 13 – TROUBLESHOOTING

| TROUBLESHOOTING CHART | | |
|--|--|--|
| PROBLEM | POSSIBLE CAUSES | POSSIBLE REMEDIES |
| No electrical power to the appliance | <ol style="list-style-type: none"> 1. Is the plug on the power supply cord unplugged from the electrical outlet? 2. Is electrical panel's 10 Amp circuit breaker tripped? 3. Is the fuse on the circuit board good? 4. Is there a power outage to the home? | <ol style="list-style-type: none"> 1. Reset the plug. 2. Reset the circuit breaker. 3. If the display panel is blank, unplug the unit or contact an authorized service technician. 4. Contact the power company. |
| No water available when a faucet is opened | <ol style="list-style-type: none"> 1. Is the water supply valve shut off at the meter (do cold water faucets work)? 2. Is the water supply valve near the unit open? 3. Is the water pipe frozen? 4. Is an error code flashing on the display panel (leak detected)? | <ol style="list-style-type: none"> 1. Open the closed supply valve. 2. Open the water supply valve. 3. Turn OFF the unit, close all water valves and the gas valve. Contact an authorized service technician. 4. Refer to error code information and contact an authorized service technician. |
| Hot water is not available when the faucet is opened. | <ol style="list-style-type: none"> 1. Does the appliance have power (plugged in)? 2. Is the appliance turned ON? 3. Is an error code flashing on the display panel? 4. Is the gas supply valve open or shut off at the meter (do other gas devices work)? | <ol style="list-style-type: none"> 1. Restore electrical power to the unit. 2. Press and hold the Power button to turn the unit ON. 3. Refer to the Diagnostic and Error Codes section in this manual. 4. Open the gas supply valve. |
| The water temperature is not hot enough or turns cold during use. | <ol style="list-style-type: none"> 1. Is the faucet open enough to draw at least 0.6 gallons (2.3L) per minute through the appliance? 2. Is an error code flashing on the display panel? 3. Is the outlet water temperature set too low? | <ol style="list-style-type: none"> 1. Open the faucet to allow more water flow. 2. Refer to the Diagnostic and Error Codes section in this manual. 3. Adjust the outlet water temperature (refer to the procedure in this manual). |
| It takes a long time before hot water flows from the faucet. | Is the faucet some distance from the appliance? | <ol style="list-style-type: none"> a. Allow time for the cold water already in the pipes to flow from the faucet. b. Have recirculation valves and/or plumbing return line(s) installed and program the unit for recirculation mode. |
| The water is not hot enough. | Is the water temperature set too low? | Adjust the temperature setting. |
| The water at the faucet is too hot. | Is the water temperature set too high? | Adjust the temperature setting. |
| A fan can be heard even when the unit is not operating. | <ol style="list-style-type: none"> 1. The fan continues to operate after the burner shuts off to clear the exhaust vent of combustion gases. 2. The fan may run to help prevent freezing. | <ol style="list-style-type: none"> 1. This is normal operation – no action is required. 2. Protect the appliance from freezing temperatures or shut off and drain the unit. |
| White "smoke" can be seen coming out of the exterior exhaust gas vent. | Depending on the outside temperature, water vapor can be produced as the exhaust is vented. | This is normal operation – no action is required. |

Table 27 – Troubleshooting Chart

DIAGNOSTICS AND SUGGESTED CORRECTIVE ACTIONS

The appliance control is able to record information about the appliance's condition at the time of the five previous faults or errors. This information is available to view in the Installer Mode under the History screen.

The following screens may be displayed when reviewing the appliance history. The table below also includes diagnostic information and possible corrective actions.

| Display | Condition | Diagnostic | Possible Corrective Actions |
|--|--|---|---|
| Nothing appears on the display control panel but the blower runs at full speed | Control is not receiving power | Check wiring for short circuit or incorrect wiring | Correct wiring per wiring diagram including connection of transformer to the control |
| | | Check transformer connection to the control per wiring diagram. Check for 12V output of transformer | Replace transformer if it is receiving 120V, but not outputting 12 VAC |
| Nothing appears on the display control panel and no other appliance components are operating | Control is not receiving 120V power | Ensure service switch and/or circuit breaker to appliance is turned ON | Turn on service switch or circuit breaker to power appliance |
| | | Is there 120V at the service switch | Troubleshoot and correct the power supply to the manual switch |
| | | Is the ON/OFF switch inside the appliance cabinet is turned on | Turn ON the manual power switch inside the appliance cabinet |
| | | Check for 120V at the line voltage terminal block located inside the appliance cabinet | Correct wiring inside the appliance cabinet using the wiring diagram in the installation manual |
| Nothing appears on the display control panel, but the appliance is operating | Occurs when communications is lost from the control to the display | Inspect the fuse. Replace as necessary | Replace the fuse with the proper part found in the replacement part section of this manual. If fuse blows again, recheck the wiring per diagram |
| | | Check for loose connections and proper pin alignment / engagement on the control's plug | Check for continuity on the wire harness from the display to the control. See repair parts section for proper replacement part. |
| | | Cycle power off and on using appliance power switch and check for operation | Replace with new display module. See repair parts section for proper replacement part. |

Table 28 –Diagnostics and Suggested Corrective Actions

PART 14 – ANNUAL MAINTENANCE PROCEDURES

DANGER

The appliance must be inspected and serviced annually, preferably at the start of the heating season, by a qualified service technician. In addition, the maintenance and care of the appliance as outlined in this manual must be performed by the user/owner to assure maximum efficiency and reliability. Follow the maintenance procedures given throughout this manual. Failure to perform the service and maintenance or follow the directions in this manual could damage the appliance or system components, resulting in substantial property damage, severe personal injury, or death.

Check the Surrounding Area

DANGER

To prevent the potential of substantial property damage, severe personal injury, or death, eliminate all the materials listed in Table 7 from the area surrounding the appliance and the vicinity of the combustion air intake. If contaminates are found:

- Remove products immediately from area.
- If contaminates have been there for an extended period, call a qualified service technician to inspect the appliance for possible damage from acid corrosion.

If products cannot be removed, immediately call a qualified service technician to re-pipe the combustion air intake piping away from the contaminated areas.

Combustible/Flammable Materials

Do not store combustible materials, gasoline, or other flammable vapors or liquids near the appliance. If found, remove these materials immediately.

Air Contaminates

If allowed to contaminate combustion air, products containing chlorine or fluorine will produce acidic condensate that will cause significant damage to the appliance. Read the list of potential contaminates and areas likely to have these contaminates in Table 7. If any of these contaminates are in the room where the appliance is located, or combustion air is taken from one of the areas listed, the contaminates must be removed immediately or the intake pipe must be relocated to another area.

Ensure the Appliance Cabinet is Closed

Ensure the appliance cabinet is closed. Tighten the two upper and lower screws to secure it. The cabinet must be closed while the appliance is running.

Check the Power Source

Make sure the power cord is properly connected. The main power line is connected to the manual switch box inside the appliance.

Check the Status of the Control Panel

Observe the Control Panel to ensure the appliance is powered on, and to check for any error codes. Clear any debris from the panel.

Check Exhaust Vent and Intake Pipe Terminations

Verify that the appliance exhaust vent and intake pipe terminations are clean and free of obstructions. Remove any debris from the exhaust vent or intake pipe openings. If removing the debris does not allow the appliance to operate correctly, contact your qualified service technician to inspect the appliance and the vent system.

Check CH and DHW Pressure Gauges

- Ensure the pressure reading on the CH gauge does not exceed 30 psig. Higher pressure readings may indicate a problem with the expansion tank.
- Ensure the pressure reading on the DHW gauge does not exceed 150 psig. Higher pressure readings may indicate a problem with the domestic expansion tank.
- Contact a qualified service technician if problem persists.

Check Exhaust Vent and Intake Piping

Visually inspect the exhaust vent for any signs of blockage, leakage, or deterioration of the piping. Inspect the exhaust vent bracing. Ensure bracing is undamaged and in good condition. Notify a qualified service technician immediately if any problems are found.

⚠ WARNING

Failure to inspect the venting system and have it repaired by a qualified service technician can result in vent system failure, causing severe personal injury or death.

Visually inspect the intake piping for any signs of blockage. Inspect the entire length of the intake pipe to ensure piping is intact and all joints are properly sealed. Inspect the intake pipe bracing. Ensure bracing is undamaged and in good condition. Notify a qualified service technician if any problems are found.

Check Pressure Relief Valve

- Visually inspect the primary pressure relief valve and discharge pipe for signs of weeping or leakage.
- If the pressure relief valve often weeps, the expansion tank may not be operating properly. Immediately contact a qualified service technician to inspect the appliance and system.

Check Vent Condensate Drain System

- While the appliance is running, check the discharge end of the condensate drain tubing. Ensure no flue gas is leaking from the condensate drain tubing by holding your fingers near the opening.
- If you notice flue gas leaking from the opening, this indicates a dry condensate drain trap. If problem persists, contact a qualified service technician to inspect the appliance and condensate line and refill the condensate trap.
- If applicable, check the condensate neutralizer and ensure it is full of condensate neutralizing marble chips.

Check the Air Vent

Loosen cap "A" one counterclockwise turn to allow air vent to operate. See Figure 45. If the air vent valve works freely without leaking, close the valve by turning clockwise. If vent does not operate correctly, contact a qualified service technician to replace the vent.

Check Primary and Gas Piping

- Remove the appliance cover and perform a gas leak inspection following Operating Instructions, page 2, this manual. If gas odor or leak is detected, follow procedures on page 2. Call a qualified service technician.
- Visually inspect for leaks around the internal appliance water connections and around the heat exchanger. Visually inspect the external system piping, circulators, and system components and fittings. Immediately call a qualified service technician to repair any leaks.

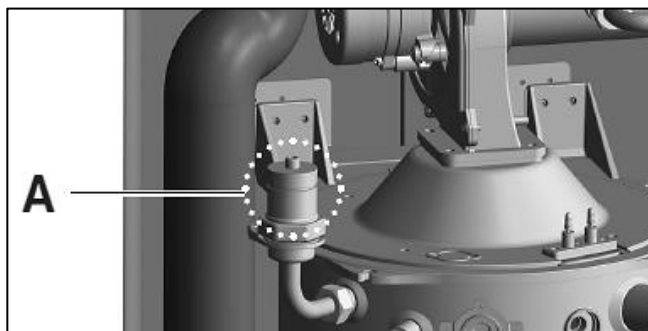

Figure 45 – Air Vent Detail

⚠ WARNING

Have leaks fixed at once by a qualified service technician. Failure to comply could result in substantial property damage, severe personal injury, or death.

Operate Pressure Relief Valve

- Before proceeding, verify that the relief valve outlet has been piped to a safe place of discharge, avoiding any possibility of scalding from hot water.

⚠ WARNING

To avoid water damage or scalding due to relief valve operation, a discharge line must be connected to the valve outlet and directed to a safe place of disposal. This discharge line must be installed by a qualified service technician or heating/plumbing installer in accordance with the appliance installation manual. The discharge line must be terminated so as to eliminate possibility of severe burns or property damage should the valve discharge.

- Read the temperature and pressure gauge to ensure the system is pressurized. Minimum is 10 psi. Maximum is 25 psi. Lift the relief valve top lever slightly, allowing water to relieve through the valve and discharge piping.
- If water flows freely, release the lever and allow the valve to seat. Watch the end of the relief valve discharge pipe to ensure that the valve does not weep after the line has had time to drain. If the valve weeps, lift the lever again to attempt to clean the valve seat. If the valve does not properly seat and continues to weep, contact a qualified service technician to inspect the valve and system.
- If water does not flow from the valve when you completely lift the lever, the valve or discharge line may be blocked. Immediately shut the appliance down per instructions on page 2 and call a qualified service technician to inspect the valve and system.

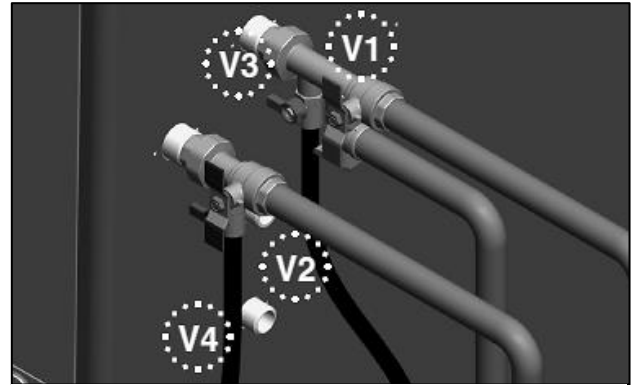

Figure 46 – Valve Detail

Check the Burner

Clean the exterior of the burner.

Flushing the DHW Heat Exchanger

Flushing the DHW heat exchanger is a complicated procedure that should only be performed by a qualified service technician. It is recommended to flush the DHW heat exchanger annually if water hardness exceeds 12 grains per gallon (considered extremely hard water). If water hardness falls below 12 grains per gallon it is recommended to flush the heat exchanger every two to three years.

NOTE: Improper maintenance WILL VOID appliance warranty.

1. Disconnect electrical power to the appliance.
2. Close the shutoff valves on both hot water outlet and cold water inlet lines (V1 and V2). See Figure 46.
3. Connect one hose (D1, Figure 47) to the valve (V3) and place the free end in a bucket. Connect one of the hoses (D3) to the circulation pump outlet and the cold water inlet line to valve V4. Connect the other hose (D2) to the circulation pump inlet and place the free end in the bucket.
4. Pour cleaning solution into the bucket. Use an FDA approved cleaner for potable systems on the heat exchanger. Place the drain hose (D1) and hose D2 to the pump inlet in the cleaning solution.
5. Open service valves (V3 and V4) on the hot water outlet and cold water inlet lines.
6. Turn on the circulation pump. Operate the pump and allow the cleaning solution to circulate through the appliance for at least 1 hour at a rate of 4 gallons per minute.
7. Rinse the cleaning solution from the DHW heat exchanger as follows:
 - a. Remove the free end of drain hose D1 from the bucket.
 - b. Close service valve V4 and open shutoff valve V2.

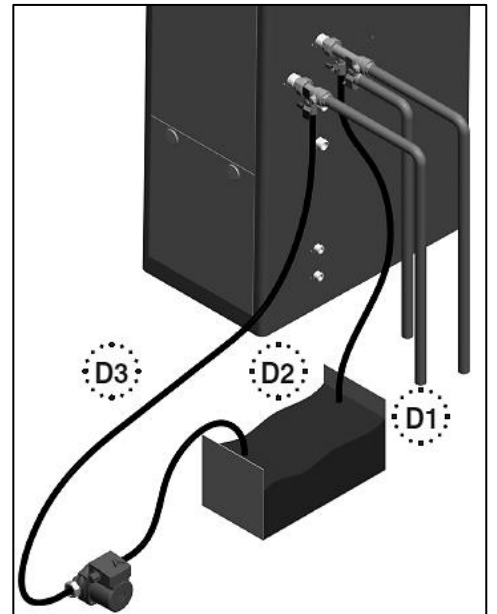

Figure 47 – Hose Connection Detail

- c. Do not open shutoff valve V1.
- d. Allow water to flow through the appliance for 5 minutes.
- e. Close shutoff valve V2.

8. Disconnect hoses from DHW lines. Properly dispose of used cleaning solution.

9. Remove the cold water inlet filter from the appliance and clean out any residues.

10. Reinsert the filter and ensure the filter cap is securely tightened.

11. Connect electrical power to the appliance.

Maintaining the Condensate System

⚠ DANGER

The condensate trap assembly **MUST BE PROPERLY INSTALLED** according to these instructions when operating the appliance. Operating the appliance without the condensate trap assembly will cause flue gases to leak and result in serious personal injury or death.

⚠ WARNING

When servicing is complete, make sure the condensate collector cap is replaced securely. Failure to do so will cause venting issues that will result in serious injury or death.

1. Ensure the appliance is powered off and has had time to cool.
2. Remove the hose clamp attaching the condensate trap to the condensate hose from the heat exchanger. Remove the clear plastic hose from the hose barb. Remove the condensate hose clamp to detach the condensate trap from the drain tube. Remove the condensate trap from the appliance.
3. Remove the bottom cap from the condensate trap.
4. Flush trap with fresh water to remove debris from the trap.

NOTE: Ensure the float moves freely within the trap. If the float does not move, **DO NOT** reinstall the trap.

5. When the condensate trap is sufficiently clean, reinstall the bottom cap on the trap.

NOTE: Ensure all parts shown in Figure 48, Condensate Detail, are installed with the condensate trap. If any parts are missing, **DO NOT** reinstall the trap. Replace the entire assembly.

⚠ WARNING

Do not install the condensate assembly if a component is lost or missing. Replace the entire assembly. Failure to follow this warning could result in property damage, serious personal injury, or death.

6. Fill the condensate trap with fresh water prior to reassembly on the appliance.

7. Install the condensate trap on the condensate hose from the heat exchanger. Use the hose clamp to secure the trap. Attach the clear plastic hose onto the hose barb. Reinstall the condensate hose clamp to detach the condensate trap from the drain tube.

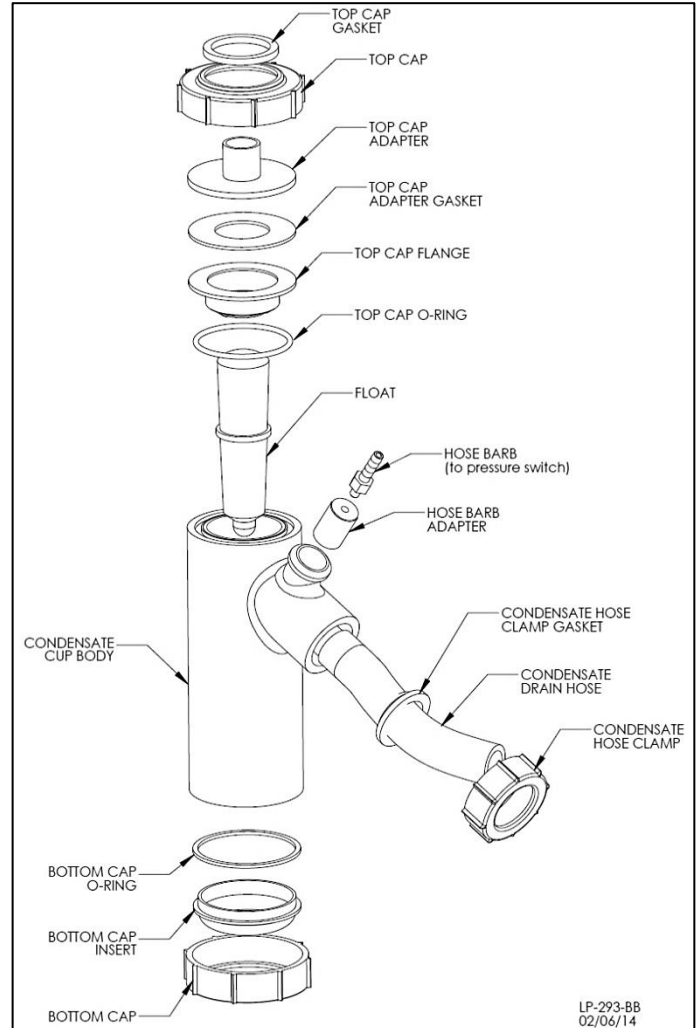

Figure 48 – Condensate Detail

⚠ WARNING

Do not operate the appliance without the clear hose attached from the hose barb to the pressure switch. Failure to follow this warning could result in property damage, serious personal injury, or death.

8. If a condensate neutralizer kit is installed with the appliance, check the assembly when cleaning the condensate trap, and replenish the limestone chips if necessary. When replacing the limestone chips, take care to ensure chips are no smaller than 1/2" to avoid blockage in condensate piping (for piping details, refer to condensate neutralizer installation instruction.)

9. Check condensate piping for sagging and/or leakage. Repair any sags or leaks before restoring power to the appliance.

| |
|----------------|
| CAUTION |
|----------------|

| |
|---|
| It is very important that the condensate piping be no smaller than 3/4". To prevent sagging and maintain pitch, condensate piping should be supported with pipe supports, and pitched 1/4" per foot to allow for proper drainage. |
|---|

| |
|----------------|
| CAUTION |
|----------------|

| |
|---|
| The condensate line must remain unobstructed, allowing free flow of condensate. If condensate freezes in the line, or if line is obstructed in any other manner, condensate can exit from the tee, resulting in potential water damage to property. |
|---|

10. If the appliance has a condensate pump, ensure the pump operates properly before considering maintenance complete.

REPLACEMENT PARTS

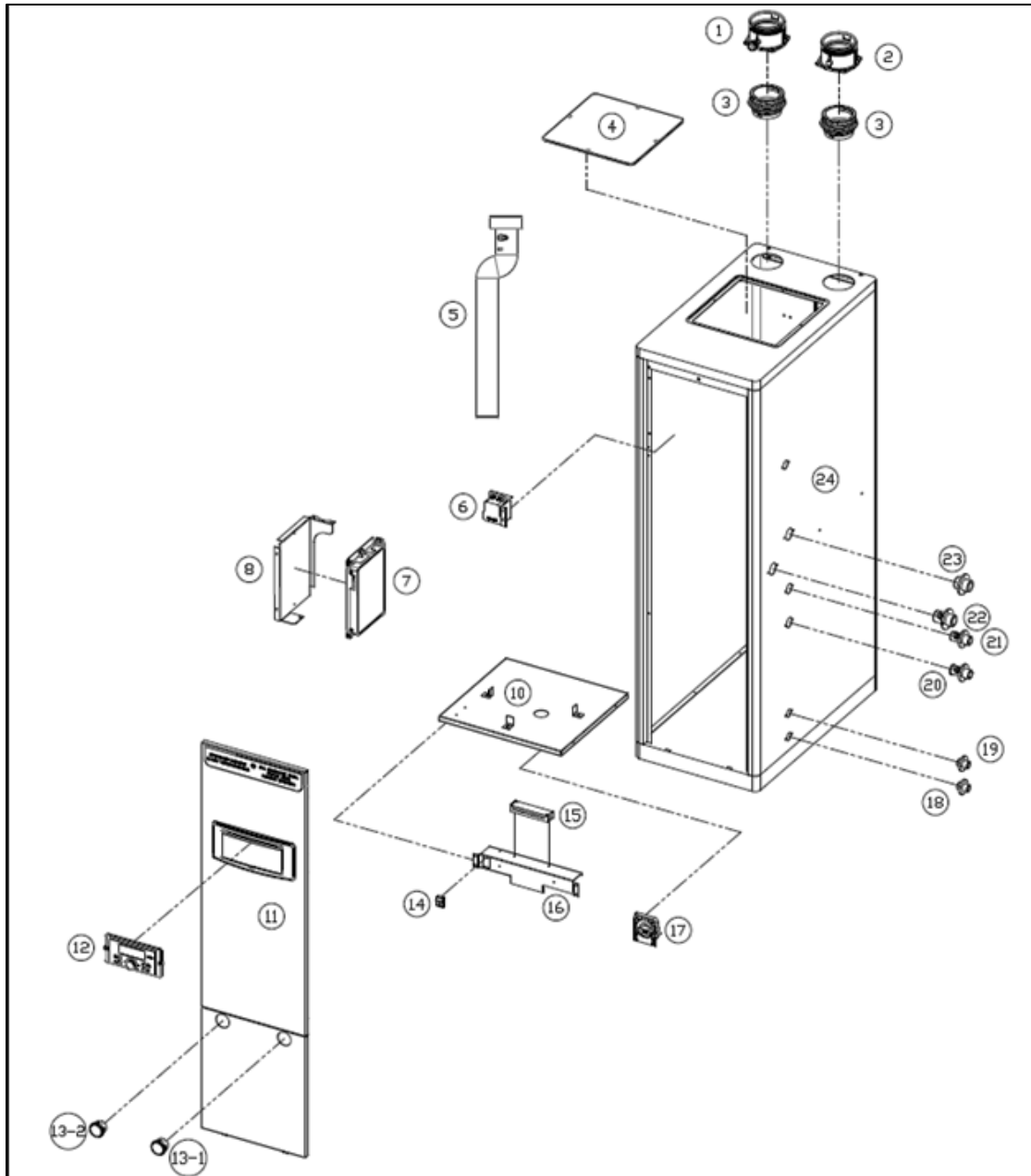

Figure 49 – Cabinet Replacement Parts

| NUMBER | DESCRIPTION | PART NUMBER | NUMBER | DESCRIPTION | PART NUMBER |
|--------|--------------------------------------|-------------|--------|--------------------------------|-------------|
| 1 | Exhaust Duct | 7855P-002 | 13-2 | DHW Pressure Gauge (0-150 PSI) | 7855P-080 |
| 2 | Air Intake Cap | 7855P-003 | 14 | Manual Power Switch | 7855P-014 |
| 3 | Exhaust and Air Intake Pipe Adapters | 7855P-004 | 15 | Terminal Block | 7855P-015 |
| 4 | A/S Cover | 7855P-005 | 16 | Front Bracket | 7855P-016 |
| 5 | Exhaust Pipe | 7855P-006 | 17 | Air Pressure Switch | 7855P-017 |
| 6 | Ignition Transformer | 7855P-007 | 18 | Drain Adapter | 7855P-018 |
| 7 | Main Control Board (PCB) | 7855P-008 | 19 | Condensate Adapter | 7855P-019 |
| 8 | Main Control Board (PCB) Bracket | 7855P-009 | 20 | DHW Inlet Adapter | 7855P-020 |
| 9 | N/A | N/A | 21 | DHW Outlet Adapter | 7855P-021 |
| 10 | Boiler Heat Exchanger Bracket | 7855P-010 | 22 | CH Return Adapter | 7855P-022 |
| 11 | Front Cover | 7855P-011 | 23 | CH Supply Adapter | 7855P-023 |
| 12 | Display Panel | 7855P-012 | 24 | Cabinet | 7855P-024 |
| 13-1 | CH Pressure Gauge (0-60 PSI) | 7855P-013 | | | |

Table 29 – Cabinet Replacement Parts

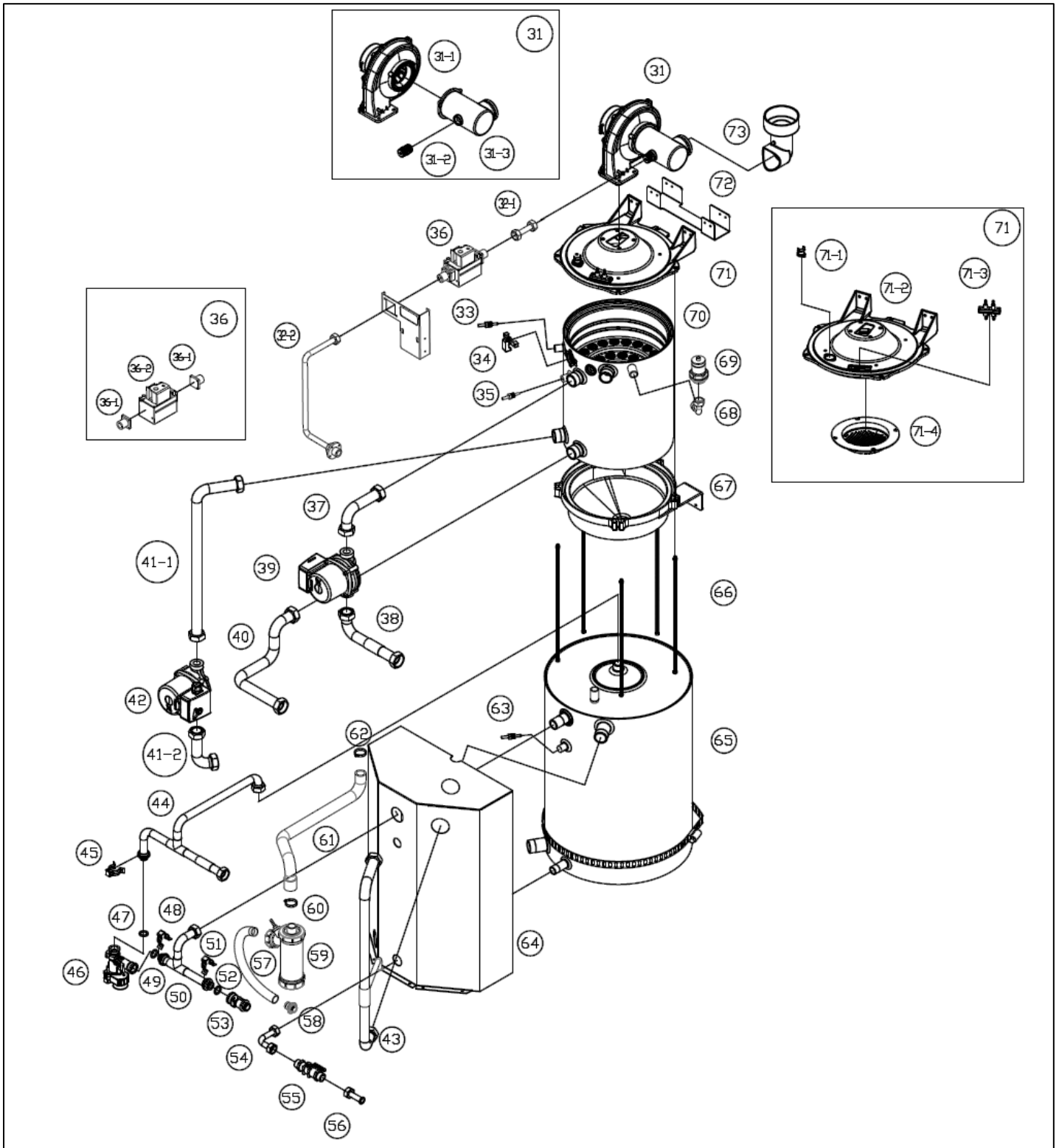

Figure 50 – Combustion System Replacement Parts

NOTE: See Replacement Parts List, following page.

| NUMBER | DESCRIPTION | PART NUMBER | NUMBER | DESCRIPTION | PART NUMBER |
|--------|--|-------------|--------|---|-------------|
| 31 | Fan Assembly | - | 51 | Flow Sensor Clip | 7855P-042 |
| 31-1 | Fan | 7855P-025 | 52 | Flow Sensor O-Ring | 7855P-047 |
| 31-2-A | Gas Orifice Nozzle (NG) | 7855P-024 | 53 | DHW Flow Sensor | 7855P-083 |
| 31-2-B | Gas Orifice Nozzle (LP) | 7855P-079 | 54 | Drain Pipe Connector 1 | 7855P-048 |
| 31-3 | Air Gas Mixer | 7855P-027 | 55 | Drain Valve | 7855P-049 |
| 32-1 | Outlet Gas Pipe | 7855P-090 | 56 | Drain Pipe Connector 2 | 7855P-050 |
| 32-2 | Inlet Gas pipe | 7855P-091 | 57 | Condensate Drain Hose | 7855P-051 |
| 33 | Water Level Detection Sensor (Low water Cutoff) | 7855P-029 | 58 | Condensate Outlet Fitting | 7855P-052 |
| 34 | Flame Sensor | 7855P-031 | 59 | Condensate Trap ASSY | 7855P-053 |
| 35 | CH Supply Temperature Sensor | 7855P-030 | 60 | Condensate Trap Inlet Clamp | 7855P-054 |
| 36 | Gas Valve ASS'Y | 7855P-032 | 61 | Condensate Hose EPDM | 7855P-055 |
| 36-1 | Gas Outlet | 7855P-033 | 62 | Condensate Collector Pan Clamp | 7855P-056 |
| 36-2 | Gas Valve | 7855P-034 | 63 | Storage Temperature Sensor | 7855P-057 |
| 37 | CH Water Supply 1 (Upper) | 7855P-036 | 64 | Water Storage Tank Bracket | 7855P-058 |
| 38 | CH Water Supply 2 (Lower) | 7855P-037 | 65 | DHW Tank ASSY | 7855P-059 |
| 39 | Internal Primary CH Pump | 7855P-081 | 66 | Heat Exchanger Long Bolt Set (5 Bolts) | 7855P-060 |
| 40 | CH Return Pipe | 7855P-038 | 67 | Condensate Collector Pan | 7855P-061 |
| 41-1 | Storage Tank Outlet Pipe (Upper) | 7855P-039 | 68 | Air Vent Pipe | 7855P-062 |
| 41-2 | Storage Tank Inlet Pipe (Lower) | 7855P-040 | 69 | Air Vent | 7855P-063 |
| 42 | Internal DHW Circulation Pump | 7855P-081 | 70 | Heat Exchanger ASSY | 7855P-064 |
| 43 | Storage Tank Outlet Pipe | 7855P-082 | 71 | Burner ASSY | 7855P-065 |
| 44 | DHW Outlet Pipe | 7855P-041 | 71-1 | Burner Overheat Switch | 7855P-066 |
| 45 | Mixing Valve Outlet Clip | 7855P-042 | 71-2 | Burner Body | 7855P-067 |
| 46 | Mixing Valve | 7855P-043 | 71-3 | Ignition Rod | 7855P-068 |
| 47 | Mixing Valve Outlet O-Ring | 7855P-044 | 71-4 | Ceramic Fiber Burner | 7855P-069 |
| 48 | Mixing Valve Inlet Clip | 7855P-042 | 72 | Burner ASSY Bracket | 7855P-070 |
| 49 | Mixing Valve Inlet O-Ring | 7855P-045 | 73 | Air intake Pipe | 7855P-071 |
| 50 | DHW Inlet Pipe | 7855P-046 | | | |

Table 30 – Combustion System Replacement Parts

Limited Warranty for Combination Appliances
Floor and Wall-Mount Models

Westinghouse warrants each instantaneous appliance and its parts to be free from defects in materials and workmanship according to the following terms, conditions, and time periods. The replacement appliance will be warranted for the unexpired portion of the applicable warranty period of the original appliance. The number of replacement appliances is limited to one (1) per original appliance purchased. Replacement parts will be warranted for 90 days. **UNLESS OTHERWISE NOTED THESE WARRANTIES COMMENCE ON THE DATE OF INSTALLATION.** This limited warranty is only available to the **original owner** of this appliance, and is non-transferable.

| Residential Use Warranty | Commercial Use Warranty |
|---|---|
| 10 years – Heat Exchanger, 5 years – Parts | 5 years – Heat Exchanger, 1 Year – Parts |
| USE DEFINITIONS - Residential Use means potable water heating in a single family residence. Commercial Use refers to all other applications, including any space heating applications. | |

COVERAGE

- A. Should a defect or malfunction result in a leakage of water within the above-stated warranty periods due to defective material or workmanship, malfunction, or failure to comply with the above warranty, Westinghouse will replace the defective or malfunctioning appliance or part(s) with a replacement of the nearest comparable model available at the time of replacement.
- B. If Westinghouse is unable to repair or replace the appliance or part(s) so as to conform to this warranty after a reasonable number of attempts, Westinghouse will then provide, at its option, a replacement appliance. These remedies are the purchaser's exclusive remedies for breach of warranty.
- C. If government regulations, industry certification, or similar standards require the replacement appliance or part(s) to have features not found in the defective appliance or part(s), the owner will be charged the difference in price represented by those required features. If the owner pays the price difference for those required features and/or to upgrade the size and/or other features available on a new replacement appliance or part(s), the owner will also receive a complete new limited warranty for that replacement appliance or part(s).
- D. If at the time of a request for service the owner cannot provide a copy of the original sales receipt or the warranty registration, the warranty period for the appliance shall then be deemed to have commenced thirty (30) days after the date of manufacture of the appliance and **NOT** the date of installation of the appliance.
- E. This warranty extends only to appliances utilized in heating applications that have been properly installed by qualified professionals based upon the manufacturer's installation instructions.

OWNER RESPONSIBILITIES

To avoid the exclusion list in this warranty, the owner or installer must:

1. Maintain the appliance in accordance with the maintenance procedure listed in the manufacturer's provided instructions. Preventive maintenance can help avoid any unnecessary breakdown of your appliance and keep it running at optimum efficiency.
2. Maintain all related system components in good operating condition.
3. If the cold water supply line has a backflow preventer, then an expansion tank should be installed to allow for water expansion.
4. Use the appliance at water pressures not exceeding the working pressure shown on the rating plate.

WARRANTY EXCLUSIONS

This limited warranty will not cover:

1. Any appliance purchased from an unauthorized dealer or online retailer.
2. Any appliance not installed by a qualified heating installer/service technician, or installations that do not conform to ANSI, CSA, and/or ETL standards, as well as any applicable national or local building codes.
3. Service trips to teach you how to install, use, maintain, or to bring the appliance installation into compliance with local building codes and regulations.
4. Failure to locate the appliance in an area where leakage of the tank or water line connections and the combination temperature and relief valve will not result in damage to the area adjacent to the appliance or lower floors of the structure.
5. Any failed components of the heat system not manufactured by Westinghouse as part of the appliance.
6. Appliances repaired or altered without the prior written approval of Westinghouse.
7. Damages, malfunctions, or failures resulting from failure to install the appliance in accordance with applicable building codes/ordinances or good plumbing and electrical trade practices.
8. Damages, malfunctions, or failures resulting from improper installation, failure to operate the appliance at pressures not exceeding the working pressure shown on the rating plate, or failure to operate and maintain the appliance in accordance with the manufacturer's provided instructions.
9. Failure to operate the appliance in an open system with a properly sized and installed thermal expansion tank.
10. Failure or performance problems caused by improper sizing of the appliance, expansion device, piping, or the gas supply line, the venting connection, combustion air openings, electric service voltage, wiring or fusing.
11. Damages, malfunctions, or failures caused by improper conversion from natural gas to LP gas or LP gas to natural gas.
12. Damages, malfunctions, or failures caused by operating the appliance with modified, altered, or unapproved parts.
13. Damages, malfunctions, or failures caused by abuse, accident, fire, flood, freeze, lightning, acts of God and the like.
14. Tank failures (leaks) caused by operating the appliance in a corrosive or contaminated atmosphere.
15. Damages, malfunctions, or failures caused by operating the appliance with an empty or partially empty tank ("dry firing"), or failures caused by operating the appliance when it is not supplied with potable water, free to circulate at all times.
16. Failure of the appliance due to the accumulation of solid materials and lime deposits.

17. Any damage or failure resulting from improper water chemistry, or heating anything other than potable water. DEFINITION OF POTABLE WATER - Potable water is defined as drinkable water supplied from utility or well water in compliance with EPA secondary maximum contaminant levels (40 CFR Part 143.3) as shown in the table. Westinghouse will warrant the heat exchanger coil for hardness up to 12 Grains per gallon.

18. Components of the appliance that are not defective, but must be replaced during the warranty period as a result of reasonable wear and tear.

19. Damages, malfunctions, or failures caused by subjecting the appliance to pressures or firing rates greater than those shown on the rating label.

20. Damages, malfunctions, or failures resulting from the use of any attachment(s) not supplied by Westinghouse.

21. Appliances moved from the original installation location.

22. Appliances that have had their rating labels removed.

| EPA DEFINITION OF POTABLE WATER | |
|---------------------------------|-------------------------|
| Contaminant | Level |
| Aluminum | 0.05 to 0.2 mg/l |
| Chloride | 250 mg/l |
| Color | 15 color units |
| Copper | 1.0 mg/l |
| Corrosivity | Non-corrosive |
| Fluoride | 2.0 mg/l |
| Foaming Agents | 0.5 mg/l |
| Iron | 0.3 mg/l |
| Manganese | 0.05 mg/l |
| Odor | 3 threshold odor number |
| pH | 6.5 – 8.5 |
| Silver | 0.1 mg/l |
| Sulfate | 250 mg/l |
| Total Dissolved Solids (TDS) | 500 mg/l |
| Zinc | 5 mg/l |

PROCEDURES FOR WARRANTY SERVICE REQUESTS

Any claim for warranty assistance must be made promptly. Determine if the appliance is “in-warranty” (that is, within the applicable warranty period) by reviewing a copy of the original sales receipt or warranty registration. The owner must present a copy of the original sales receipt or warranty registration for a warranty service request.

If the appliance is “in-warranty”, contact the distributor from whom the

appliance was purchased (or the installer) for assistance. Be prepared to provide the retailer or installer with a copy of the original receipt, complete model and serial numbers, and the date of installation of the appliance, in addition to explanation of the appliance problem.

Warranty coverage is subject to validation of “in-warranty” coverage by Westinghouse claims department personnel. All alleged defective or malfunctioning parts must be returned to Westinghouse via the **local distribution channels** where original purchase was made. **NOTE: Any parts or appliances returned to Westinghouse for warranty analysis will become the property of Westinghouse and will not be returned, even if credit is denied.** If all warranty conditions are satisfied, Westinghouse will provide replacement parts to the retailer.

For questions about the coverage of this warranty, please contact Westinghouse at the phone number stated below:

1-774-417-6000

SERVICE, LABOR AND SHIPPING COSTS

This limited warranty does not extend to any shipping charges, delivery expenses, or administrative fees incurred by the owner in repairing or replacing the appliance or part(s). This warranty does not extend to labor costs beyond the coverage specified in this warranty document. All such expenses are the owner’s responsibility.

LIMITATIONS OF YOUR WESTINGHOUSE WARRANTY AND REMEDIES

THE FOREGOING WARRANTIES ARE EXCLUSIVE AND ARE GIVEN AND ACCEPTED IN LIEU OF ANY AND ALL OTHER WARRANTIES, EXPRESS OR IMPLIED, INCLUDING WITHOUT LIMITATION THE IMPLIED WARRANTIES OF MERCHANTABILITY AND FITNESS FOR A PARTICULAR PURPOSE AND ANY OBLIGATION, LIABILITY, RIGHT, CLAIM OR REMEDY IN CONTRACT OR TORT, WHETHER OR NOT ARISING FROM WESTINGHOUSE’S NEGLIGENCE, ACTUAL OR IMPUTED. THE REMEDIES OF THE PURCHASER SHALL BE LIMITED TO THOSE PROVIDED HEREIN TO THE EXCLUSION OF ANY OTHER REMEDIES INCLUDING WITHOUT LIMITATION, INCIDENTAL OR CONSEQUENTIAL DAMAGES, SAID INCIDENTAL AND CONSEQUENTIAL DAMAGES INCLUDING, BUT NOT LIMITED TO, PROPERTY DAMAGE, LOST PROFIT OR DAMAGES ALLEGED TO HAVE BEEN CAUSED BY ANY FAILURE OF WESTINGHOUSE TO MEET ANY OBLIGATION UNDER THIS AGREEMENT INCLUDING THE OBLIGATION TO REPAIR AND REPLACE SET FORTH ABOVE. NO AGREEMENT VARYING OR EXTENDING THE FOREGOING WARRANTIES, REMEDIES OR THIS LIMITATION WILL BE BINDING UPON WESTINGHOUSE. UNLESS IN WRITING AND SIGNED BY A DULY AUTHORIZED OFFICER OF WESTINGHOUSE. THE WARRANTIES STATED HEREIN ARE NOT TRANSFERABLE AND SHALL BE FOR THE BENEFIT OF THE ORIGINAL PURCHASER ONLY.

NO OTHER WARRANTIES

This Westinghouse Warranty gives you specific legal rights, and you may also have other rights that vary from state to state. Some states do not allow the exclusion or limitation of incidental or consequential damages so this limitation or exclusion may not apply to you.

These are the only written warranties applicable to the commercial appliance manufactured and sold by Westinghouse. Westinghouse neither assumes nor authorizes anyone to assume for it any other obligation or liability in connection with said commercial appliances. Westinghouse reserves the right to change specifications or discontinue models without notice.

MAINTENANCE REPORT**CAUTION**

In unusually dirty or dusty conditions, care must be taken to keep appliance cabinet door in place at all times. Failure to do so VOIDS WARRANTY!

The appliance requires minimal periodic maintenance under normal conditions. However, in unusually dirty or dusty conditions, periodic vacuuming of the cover to maintain visibility of the display and indicators is recommended.

Periodic maintenance should be performed once a year by a qualified service technician to assure that all the equipment is operating safely and efficiently. The owner should make necessary arrangements with a qualified heating contractor for periodic maintenance of the appliance. Installer must also inform the owner that the lack of proper care and maintenance of the appliance may result in a hazardous condition.

| INSPECTION ACTIVITIES | | DATE LAST COMPLETED | | | |
|--------------------------|---|----------------------|----------------------|----------------------|-----------------------|
| | | 1 st YEAR | 2 nd YEAR | 3 rd YEAR | 4 th YEAR* |
| PIPING | | | | | |
| Near appliance piping | Check appliance and system piping for any sign of leakage. Leaking pipes could cause property damage. Make sure all piping is properly supported. | | | | |
| Vent | Check condition of all vent pipes and joints. Ensure all vent piping is properly supported. Check for obstructions exhaust and intake termination points. | | | | |
| Gas | Check Gas piping, test for leaks and signs of aging. Make sure all pipes are properly supported. | | | | |
| SYSTEM | | | | | |
| Visual | Do a full visual inspection of all system components. | | | | |
| Functional | Test all functions of the system (central heating, water heating, safeties) | | | | |
| Temperatures | Verify safe settings on appliance or Anti-Scald Valve | | | | |
| Temperatures | Verify programmed temperature settings | | | | |
| ELECTRICAL | | | | | |
| Connections | Check wire connections. Make sure they are tight. | | | | |
| Smoke and CO detector | Verify devices are installed and working properly. Change batteries if necessary. | | | | |
| Circuit Breakers | Check to see that the circuit breaker is clearly labeled. Exercise circuit breaker. | | | | |
| Switch and Plug | Verify ON/OFF switch and convenience plug are both functional | | | | |
| CONDENSATE | | | | | |
| Neutralizer | Check condensate neutralizer. Replace if necessary. | | | | |
| Condensate hose | Disconnect condensate hose. Clean out dirt and re-install. (NOTE: Verify the flow of condensate, making sure that the hose is properly connected during final inspection.) | | | | |
| GAS | | | | | |
| Pressure | Measure incoming gas pressure (3.5" to 14" W.C.) | | | | |
| Pressure Drop | Measure drop in pressure on light off (no more than 1" W.C.) | | | | |
| Check gas pipe for leaks | Check piping for leaks. Verify that all are properly supported. | | | | |
| COMBUSTION | | | | | |
| CO/CO2 Levels | Check CO and CO2 levels in Exhaust. Record at high and low fire. | | | | |
| SAFETIES | | | | | |
| ECO (Energy Cut Out) | Check continuity on Flue ECO. Replace if corroded. | | | | |
| DHW SYSTEM | | | | | |
| | It is recommended to flush the DHW heat exchanger annually if water hardness exceeds 12 grains per gallon (considered extremely hard water). If water hardness falls below 12 grains per gallon it is recommended to flush the heat exchanger every two to three years. | | | | |
| FINAL INSPECTION | | | | | |
| Check list | Verify that you have completed entire check list. WARNING: FAILURE TO DO SO COULD RESULT IN SERIOUS INJURY OR DEATH. | | | | |
| Homeowner | Review what you have done with the homeowner. | | | | |
| TECH SIGN OFF | | | | | |

Table 31 - *Continue annual maintenance beyond the 4th year as required.

ADDITIONAL INSTALLATION REQUIREMENTS FOR THE COMMONWEALTH OF MASSACHUSETTS

In the Commonwealth of Massachusetts, the installer or service agent shall be a plumber or gas fitter licensed by the Commonwealth.

When installed in the Commonwealth of Massachusetts or where applicable state codes may apply; the unit shall be installed with a CO detector per the requirements listed below.

5.08: Modifications to NFPA-54, Chapter 10

(1) Revise NFPA-54 section 10.5.4.2 by adding a second exception as follows:

Existing chimneys shall be permitted to have their use continued when a gas conversion burner is installed, and shall be equipped with a manually reset device that will automatically shut off the gas to the burner in the event of a sustained back-draft.

(2) Revise 10.8.3 by adding the following additional requirements:

(a) For all side wall horizontally vented gas fueled equipment installed in every dwelling, building or structure used in whole or in part for residential purposes, including those owned or operated by the Commonwealth and where the side wall exhaust vent termination is less than seven (7) feet above finished grade in the area of the venting, including but not limited to decks and porches, the following requirements shall be satisfied:

1. INSTALLATION OF CARBON MONOXIDE DETECTORS. At the time of installation of the side wall horizontal vented gas fueled equipment, the installing plumber or gasfitter shall observe that a hard wired carbon monoxide detector with an alarm and battery back-up is installed on the floor level where the gas equipment is to be installed. In addition, the installing plumber or gasfitter shall observe that a battery operated or hard wired carbon monoxide detector with an alarm is installed on each additional level of the dwelling, building or structure served by the side wall horizontal vented gas fueled equipment. It shall be the responsibility of the property owner to secure the service of qualified licensed professionals for the installation of hard wired carbon monoxide detectors

a. In the event that the side wall horizontally vented gas fueled equipment is installed in a crawl space or an attic, the hard wired carbon monoxide detector with alarm and battery back-up may be installed on the next adjacent floor level.

b. In the event that the requirements of this subdivision cannot be met at the time of completion of installation, the owner shall have a period of thirty (30) days to comply with the above requirements; provided, however, that during said thirty (30) day period, a battery operated carbon monoxide detector with an alarm shall be installed.

2. APPROVED CARBON MONOXIDE DETECTORS. Each carbon monoxide detector as required in accordance with the above provisions shall comply with NFPA 720 and be ANSI/UL 2034 listed and IAS certified.

3. SIGNAGE. A metal or plastic identification plate shall be permanently mounted to the exterior of the building at a minimum height of eight (8) feet above grade directly in line with the exhaust vent terminal for the horizontally vented gas fueled heating appliance or equipment. The sign shall read, in print size no less than one-half (1/2) inch in size, "GAS VENT DIRECTLY BELOW, KEEP CLEAR OF ALL OBSTRUCTIONS".

4. INSPECTION. The state or local gas inspector of the side wall horizontally vented gas fueled equipment shall not approve the installation unless, upon inspection, the inspector observes carbon monoxide detectors and signage installed in accordance with the provisions of 248 CMR 5.08 (2)(a) 1 through 4.

(b) EXEMPTIONS: the following equipment is exempt from 248 CMR 5.08 (2)(a) 1 through 4:

1. The equipment listed in Chapter 10 entitled "Equipment Not Required to be Vented" in the most current edition of NFPA 54 as adopted by the Board; and
2. Product Approved side wall horizontally vented gas fueled equipment installed in a room or structure separate from the dwelling, building or structure used in whole or in part for residential purposes.

(c) MANUFACTURER REQUIREMENTS – GAS EQUIPMENT VENTING SYSTEM PROVIDED. When the manufacturer of Product Approved side wall horizontally vented gas equipment provides a venting system design or venting system components with the equipment, the instructions provided by the manufacturer for installation of the equipment and the venting system shall include:

1. Detailed instructions for the installation of the venting system design or the venting system components; and
2. A complete parts list for the venting system design or venting system.

(d) MANUFACTURER REQUIREMENTS – GAS EQUIPMENT VENTING SYSTEM NOT PROVIDED. When the manufacturer of a Product Approved side wall horizontally vented gas fueled equipment does not provide the parts for venting the flue gases, but identifies "special venting systems", the following requirements shall be satisfied by the manufacturer:

1. The referenced "special venting system" instructions shall be included with the appliance or equipment installation instructions; and
2. The "special venting systems" shall be Product Approved by the Board, and the instructions for that system shall include a parts list and detailed installation instructions.

(e) A copy of all installation instructions for all Product Approval side wall horizontally vented gas fueled equipment, all venting instructions, all parts lists for venting instructions, and/or all venting design instructions shall remain with the appliance or equipment at the completion of the installation.

CUSTOMER INSTALLATION RECORD FORM

The following form should be completed by the installer for you to keep as a record of the installation in case of a warranty claim. After reading the important notes at the bottom of the page, please also sign this document.

| | |
|---|--|
| Customer's Name: | |
| Installation Address: | |
| Date of Installation: | |
| Installer's Code/Name: | |
| Product Serial Number(s): | |
| Combustion Setting at Time of Installation: | |
| Comments: | |
| Installer's Phone Number: | |
| Signed by Installer: | |
| Signed by Customer: | |

IMPORTANT NOTES:

Customer: Please only sign after the installer has reviewed the installation, safety, proper operation and maintenance of the system. In the case that the system has any problems, please call the installer. If you are unable to make contact, please contact your Sales Representative.

Distributor/Dealer: Please insert contact details.