

CHP9536SJ

GE Café™ Series 36" Built-In Touch Control Induction Cooktop

Dimensions and Installation Information (in inches)

Important: Requires a 5" free area between the bottom of the cooktop to any combustible material, i.e., shelving. Free area not required when installing wall oven underneath cooktop. Refer to installation instructions. Requires a 15" minimum from cooktop to adjacent overhead cabinets. Units are furnished with a 48" flexible armored cable.

Note: 36" induction cooktops are approved for use over select GE 30" Single Wall Ovens and Warming Drawers. Refer to cooktop and wall oven/warming drawer installation instructions packed with product for current dimensional data. If installed with a GE Telescopic Downdraft System, consult both the cooktop and downdraft installation instructions packed with product before installing. Cooktop gas/electric supply may need to be re-routed to install downdraft. The countertop cutout requires 23-1/2" minimum flat countertop surface and 25" minimum total countertop depth. In addition, other clearances to front edge of the countertop must be considered.

Before installing, consult installation instructions packed with product for current dimensional data.

Approximate Cooking Dimensions

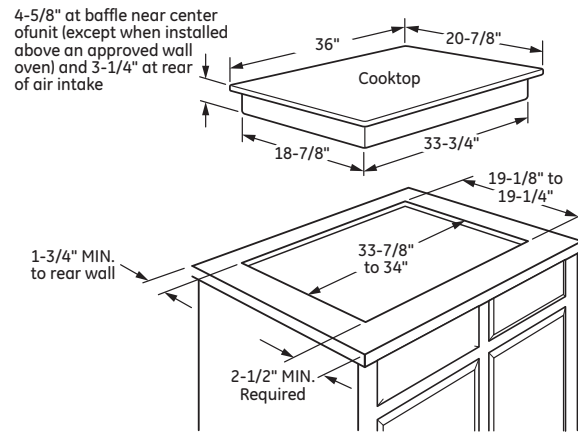

To insure accuracy, it is best to make a template when cutting the opening in the counter

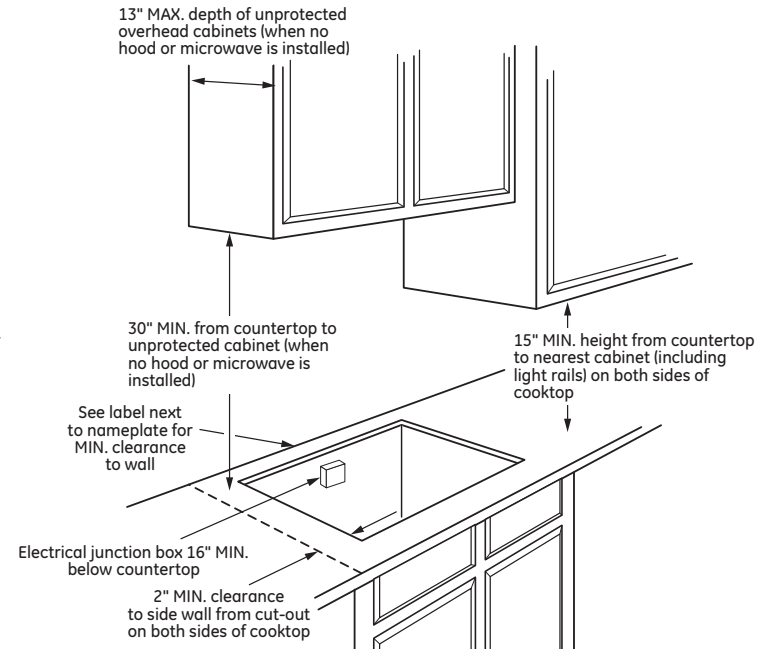

KW Rating	
240V	11.1
208V	9.6
Amperage	
240V	46.3 Amps†
208V	46.3 Amps†

†Note: Check local codes for required breaker size



imagination at work

For answers to your Monogram® or GE appliance questions, visit our website at geappliances.com or call GE Answer Center® service, 800.626.2000.



Listed by Underwriters Laboratories

CHP9536SJ

GE Café™ Series 36" Built-In Touch Control Induction Cooktop

Features and Benefits

- Five Induction elements - Enjoy a new level of rapid, precise heating with a cool-to-the-touch surface that's easy to clean
- Glide touch controls - Precisely control heat instantly and easily with one swipe
- 11" 3,700-watt induction element - Rapidly boil water with GE's most powerful induction element
- SyncBurners - Control two 7" elements simultaneously to evenly heat large cookware or griddles
- Stainless Steel Clad Aluminum Griddle - Achieve even results with this lightweight griddle, tailored to fit GE SyncBurners
- Multi-element timer - Manage up to five pans at once with individual timers for each element
- Control lock capability - Protects against unintended activation
- Custom Settings - Personalize your cooktop settings to fit your cooking style
- Pan presence & size sensor - Cook efficiently with elements that heat to the size of your pan and shut off when no pan is present
- Blue LED display with beveled gray glass surface - Enjoy a premium look that blends in with modern kitchen finishes
- Model CHP9536SJSS - Stainless steel

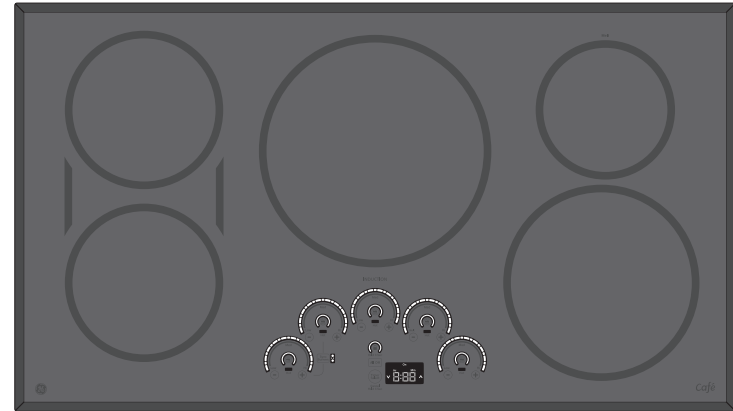

Optional Precision Cooking Kit

Achieve restaurant quality results with a probe that wirelessly controls the temperature of your food. Ideal for Sous Vide, Slow Cooking, making candy, etc., or for any other cooking that requires precise control of temperature over time. Order part number JXSOUV1 from your GE Dealer.