

## CARE AND MAINTENANCE

### Furniture Care

- Wipe spills with a clean dry soft cloth.
- Wash frame with a mild solution of soap and water; rinse with clean water and dry thoroughly.
- Avoid the use of harsh cleaners and abrasives.
- Cover furniture with outdoor covers (sold separately) when left outside during inclement weather or when not in use.
- Make sure furniture is completely dry before storage.

### Cushion Care

- Clean with a solution comprised of one tablespoon of liquid dish soap to a gallon of water. Wipe with a sponge or cloth, rinse well, and air dry.
- Never use bleach or harsh cleaners.
- Do not machine wash.
- Store cushions separately from furniture to prevent possible transfer of moisture.
- To prevent mildew, ensure fabric is completely dry before storage.



### WARNING

- **The maximum weight capacity for this chair is 300lbs/113kg. Please do not exceed the weight capacity to avoid injury or product damage.**

### WARRANTY

- This is a residential warranty and does not apply for commercial use.
- Arden Companies warrants this product against defects in workmanship and materials for 5 years from date of purchase.
- Arden Companies warrants the cushions against defects in workmanship and materials for 3 years from date of purchase.
- This warranty gives you specific legal rights, and you may have other rights which vary from state to state.
- Any implied warranty, including the warranty of merchantability, is limited to the duration of this warranty.
- Regular care and maintenance are required to maintain warranty.
- Shipping charges are non-refundable. Customer must cover shipping and handling charges when filing a claim.
- We will repair or replace the defective part at our sole discretion.
- For any warranty claim or questions, please call Customer Service 1-800-876-7336 with your date of purchase, a valid receipt, product model number, and description of defect, including photographs or physical inspection of the product.

**BOMBAY**  
—  —  
**OUTDOORS**

We guarantee that every product we sell will stand up to the supreme test — our customers' satisfaction.

**BOMBAY**  
—  —  
**OUTDOORS**

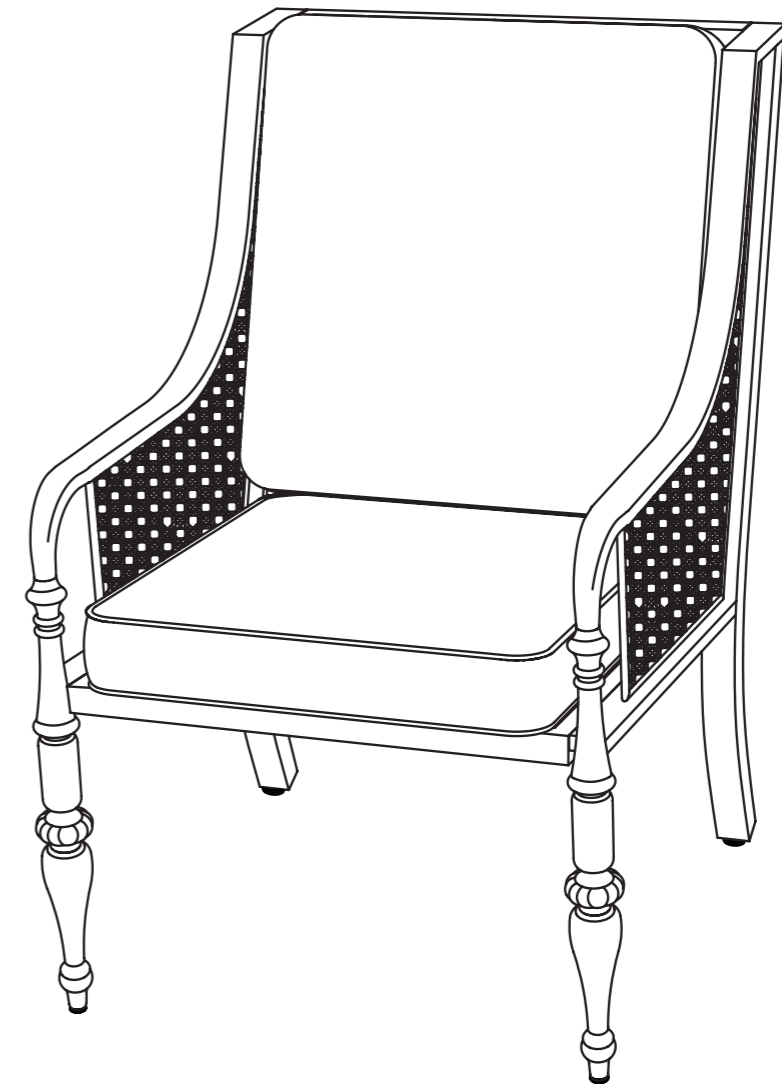



**Sherborne Dining Chair**

For questions or comments about your product, please contact us at [customerservice@ardencompanies.com](mailto:customerservice@ardencompanies.com) or call our toll free customer service number 1-800-876-7336.

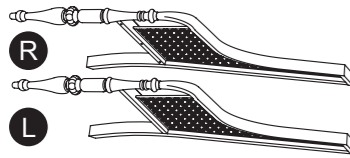
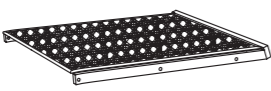
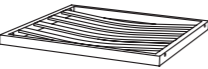
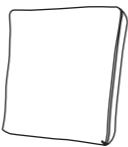

# BOMBAY

OUTDOORS

## LARGE PIECES

A	B	C	D	E
Arm (R&L)	Chair Back	Chair Seat	Back Cushion	Seat Cushion
				
2	1	1	1	1

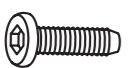
## SMALL PIECES

F	G	H
Small Allen Bolt (1/4" x 28mm)	Large Allen Bolt (1/4" x 32mm)	Flat Washer
		
6	4	10

## TOOLS

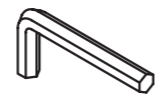
I
Allen Wrench (4mm)

1



### CAUTION

Read all instructions before assembly and use of this product. Failure to follow these instructions and warnings could result in injury or damage to the item. Keep these instructions for future reference.

## ASSEMBLY NOTES

- Please make sure that you have all the parts indicated before you begin assembly.
- Items should be assembled on a soft surface to avoid scratching during assembly.
- This product may need periodic tightening. We recommend tightening every 6 months.
- **Caution: Do not overtighten.**

## ASSEMBLY INSTRUCTIONS

1. Begin by placing the right arm (A-R) down on a soft flat surface.
2. Attach the chair seat (C) to the right arm (A-R) using 2 large Allen Bolts (G), and 2 flat washers (H). Do not tighten the bolts until all parts are assembled together. (Fig. 1)

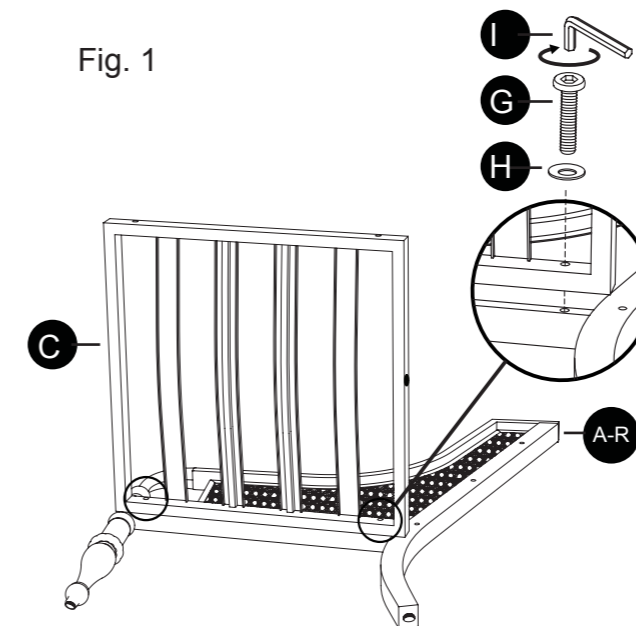

3. Attach the chair back (B) to the right arm (A-R) by using 3 small Allen bolts (F) and 3 flat washers (H). (Fig. 2)

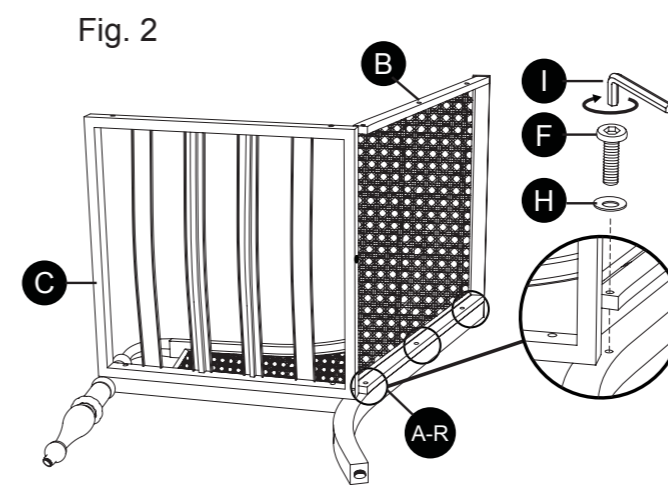

4. Attach the assembled unit to the left arm (A-L) by using 2 large Allen bolts (G), 3 short Allen bolts (F) and 5 flat washers (H).

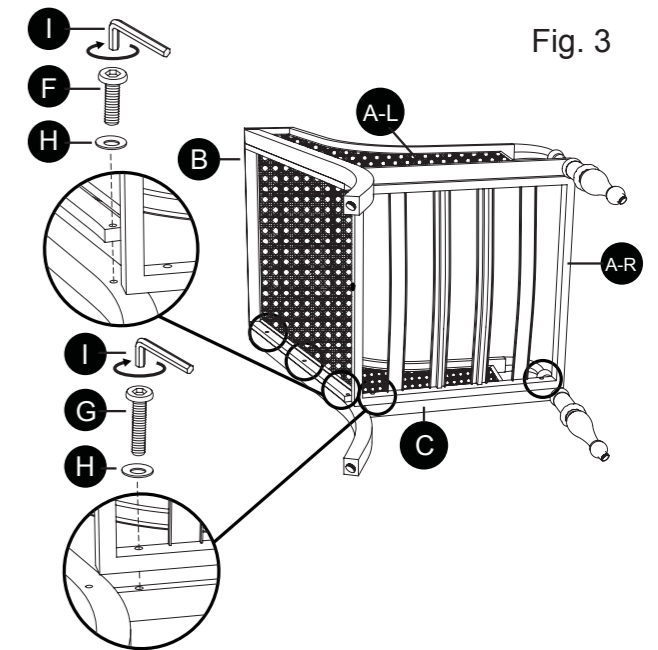

5. Ensure all bolts are aligned and assembled correctly.
6. Fully tighten all Allen bolts (F) and (G) with the Allen wrench (I).
7. Turn the chair over to its upright position.
8. Place the seat cushion (E), the back cushion (D) onto the chair.

