

# Installation Instructions / Warranty

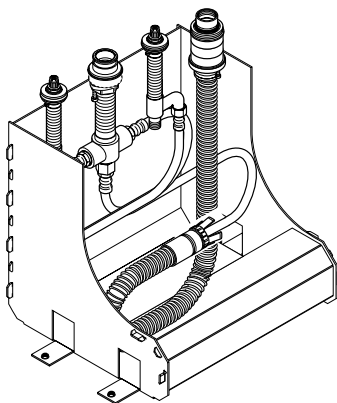

13444181

**hansgrohe**

# Four-hole Roman Tub Rough

## 13444181

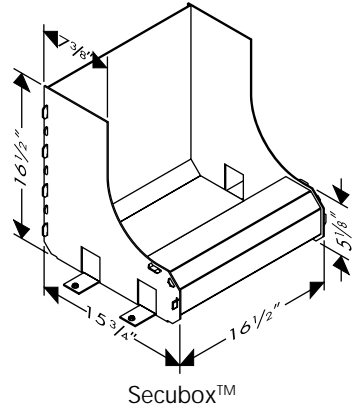
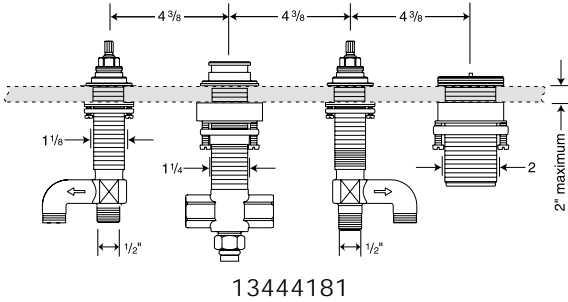

### Technical Specifications

Operating pressure:	max. 145 psi
Recommended operating pressure:	14.5 - 72.5 psi
Hot water temperature:	max. 176° F*
Recommended hot water temperature:	120° F - 140° F*
Connections:	cold right - hot left 1/2"
Rate of flow:	approx. 5.8 gpm

This unit is listed by UL.

\*Please know and follow all applicable local plumbing codes when setting the temperature on the water heater. In Massachusetts, the water heater may be set no higher than 112°F.

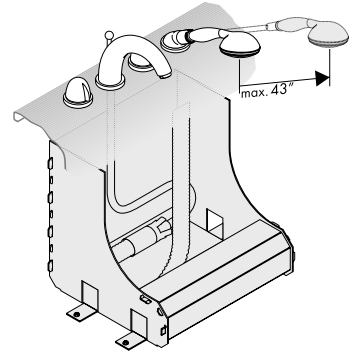

### Installation Considerations

This unit includes a cutout template, which must be used. Custom installations may require additional parts which cannot be furnished by Hansgrohe.

This unit must be completed with a trim kit. The handshower must be installed.

Protection against back siphonage is provided by a check valve (included with the trim kit) and by an automatically resetting diverter (included with the trim kit).

**Important:** If Axor Citterio trim kit **39452XX1** or **39456XX1** is to be used, this rough must be installed with mounting plate 39449001 (not included).

To insure proper fit of the trim, the surface material (tile, etc) must be installed prior to installation of this rough.

**Available trim kits (not included)**

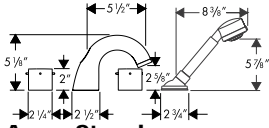

**Axor Starck**  
10454XX1

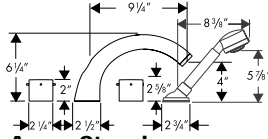

**Axor Starck**  
10444XX1

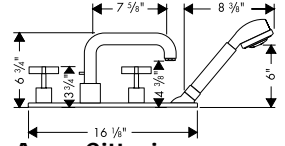

**Axor Citterio**  
39452XX1  
mounting plate 39449001  
required

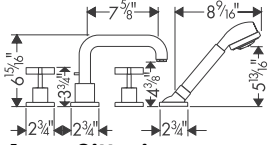

**Axor Citterio**  
39453XX1

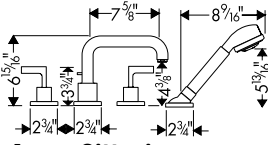

**Axor Citterio**  
39454XX1

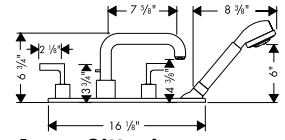

**Axor Citterio**  
39456XX1  
mounting plate 39449001  
required

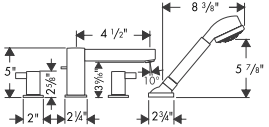

**Axor Steel**  
35444801

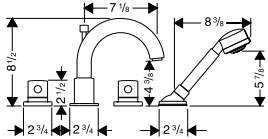

**Axor Uno**  
38447XX1

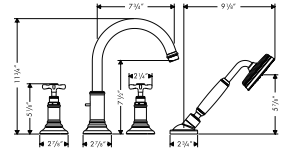

**Axor Montreux**  
16544XX1

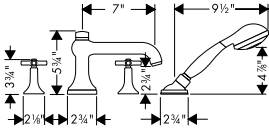

**Axor Terrano**  
37447XX1

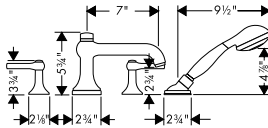

**Axor Terrano**  
37547XX1

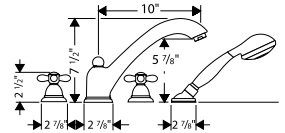

**Axor Carlton**  
17454XX1

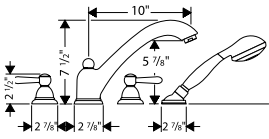

**Axor Carlton**  
17455XX1

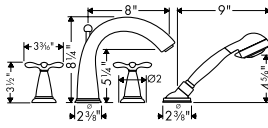

**Axor Phoenix**  
17446XX1

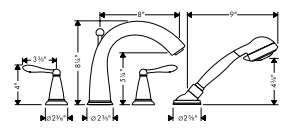

**Axor Phoenix**  
17447XX1

## Installation

Position the template on the mounting surface (1). Drill the holes according to the template (2).

Make sure that there is sufficient space under the mounting surface for the Secubox.

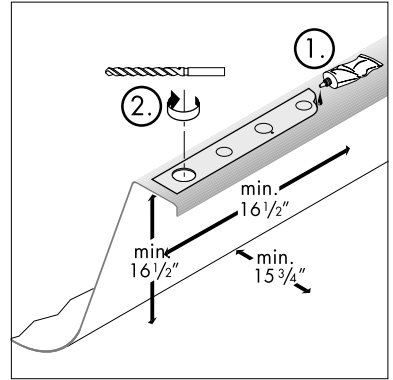

Wrap the threads on the hoses included with this kit with Teflon thread tape. Install them on the diverter housing.

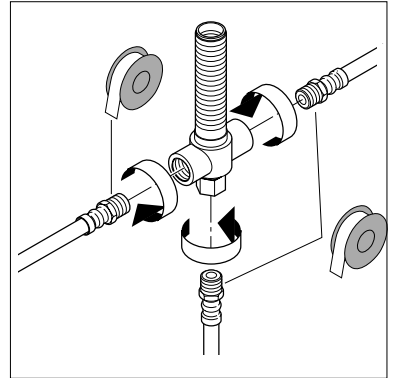

Install the mounting nuts, metal washers, and friction washers on the hot and cold valves. From below the mounting surface, push the valves up through the holes.

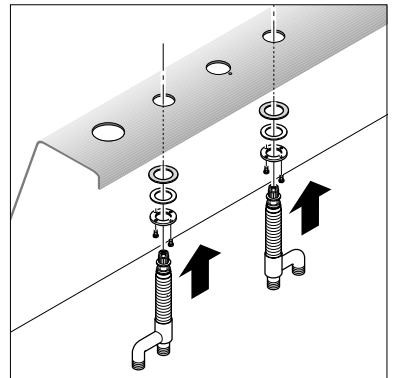

From above the mounting surface, install the stop ring and mounting plate on the valve (1). The stop ring will stop the mounting plate at the correct height. Lower the valve so that the mounting plate rests on the mounting surface (2).

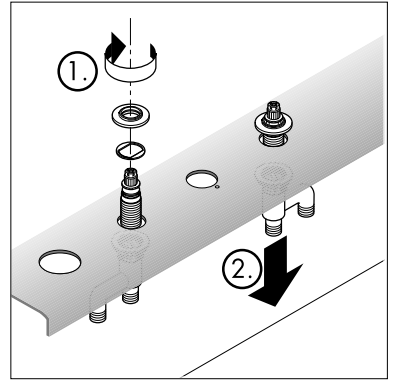

Tighten the mounting nuts (1). Tighten the tensioning screws (2).

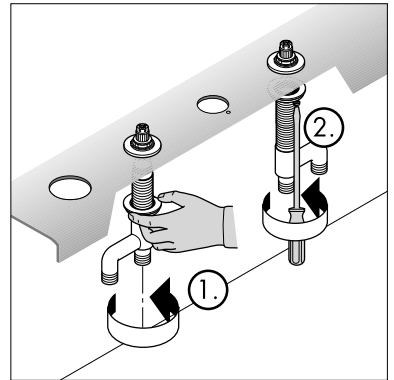

Install the mounting nut, metal washer, and friction washer on the diverter housing (1). Omit the white plastic spacer unless the mounting surface is thin. From below the mounting surface, push the diverter housing up through the hole in the mounting surface.

From above the mounting surface, install the sealing gasket and spout base on the tee as far as the spout base will go without forcing it (2). Lower the diverter housing so that the spout base rests flat on the sealing ring and mounting surface, and the retaining pin goes through its hole.

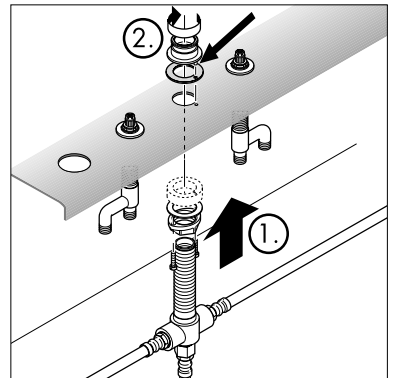

Tighten the mounting nut (1). Tighten the tensioning screws (2).

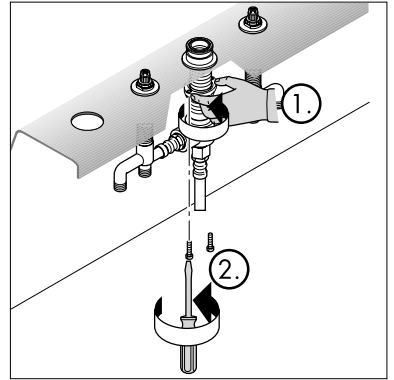

Install the connecting hoses on the valve outlet ports.

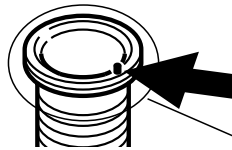
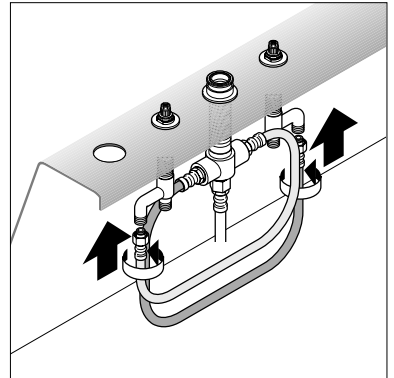

Place the Secuflex holder in its hole on the mounting surface (1). Turn it so that the positioning pin is on the side away from the bather.

Install the mounting nut, metal washer, and friction washer (2). If the mounting surface is thin, install the spacers as well.

Tighten the mounting nut (3). Tighten the tensioning screws (4).

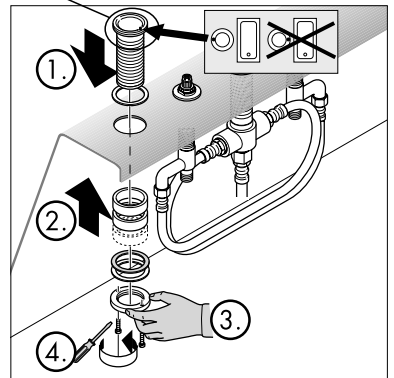

Connect the hot and cold supply lines (not included) (1).

Push the Secuflex hose down through the holder (2).

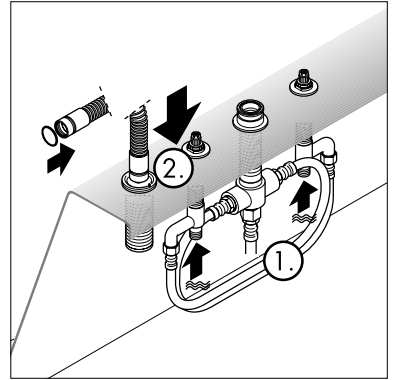

Install the plug on the spout base (1).

Remove the plug from the high pressure hose (2).

Turn the water on and flush the unit (3).

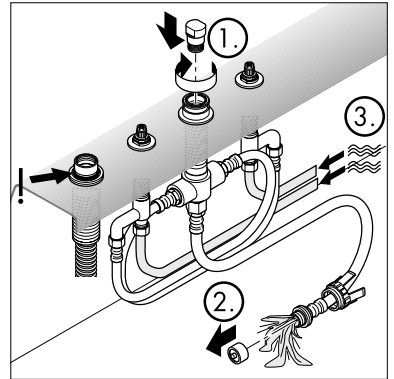

Turn the water off.

Replace the plug on the high pressure hose (1). Pressure test the unit (2). Check all connections for leaks.

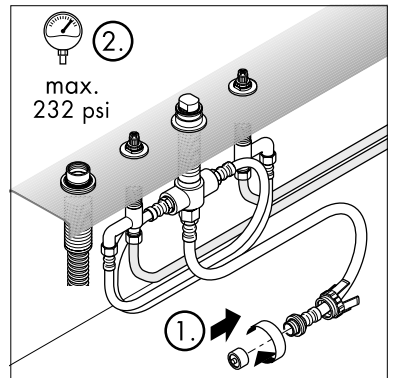

Push the Secuflex hose over the end of the high pressure hose (1). Tighten the nut (2).

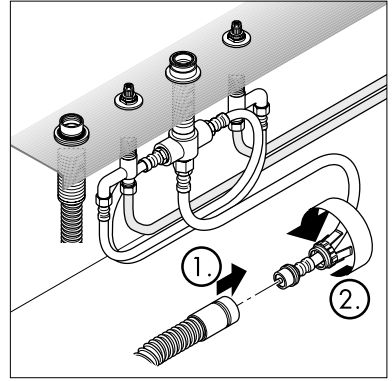

Install the plaster shields on the valves, diverter housing, and handshower holder to protect the unit until construction is complete and the trim is installed.

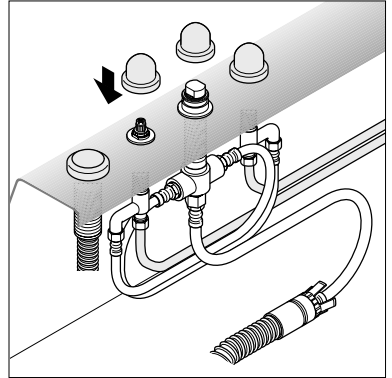

Install the Secubox. Cut it if necessary to make a good fit.

Mark the positions of the screw holes. Drill the holes with a 6 mm bit. Secure the Secubox to the floor with the screws.

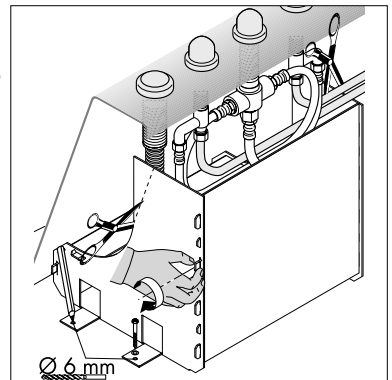



# Replacement Parts

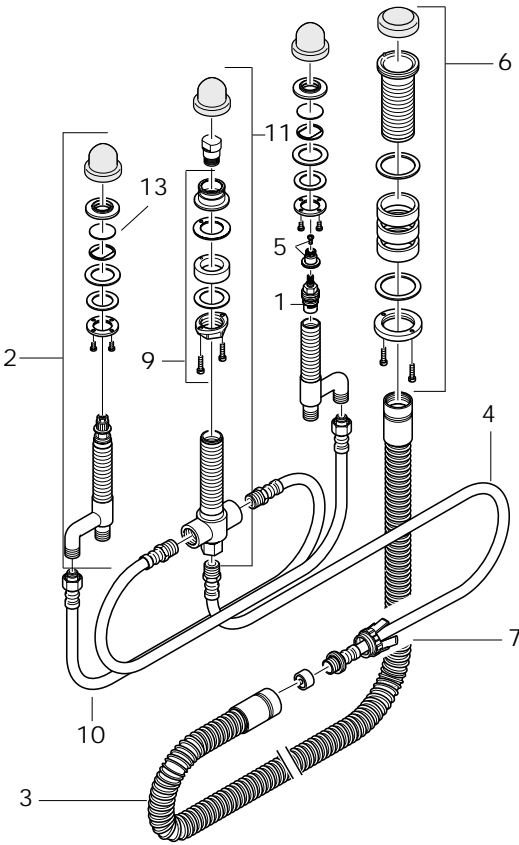

- |    |                             |          |
|----|-----------------------------|----------|
| 1  | cartridge                   | 94149000 |
| 2  | stop valve                  | 92944000 |
| 3  | Secuflex hose               | 94108000 |
| 4  | connecting hose             | 94174000 |
| 5  | handle fixing set           | 94184000 |
| 6  | fixing set for Secuflex     | 96072000 |
| 7  | nut for Secuflex            | 96074000 |
| 8  | fixing set for stop valve   | 96078000 |
| 9  | fixing set for diverter hsg | 96080000 |
| 10 | pressure hose               | 96565000 |
| 11 | diverter housing            | 96125000 |
|    | Secubox™                    | 28389000 |

## Cleaning Recommendation for Hansgrohe Products

Modern faucetry and shower products utilize a combination of materials to comply with the needs of the market with regard to design and functionality.

To avoid damage, it is necessary to use some caution when cleaning. Damage caused by improper treatment is not covered under the Hansgrohe warranty.

### Cleaning Materials for Faucets and Showers

- To remove lime scale, use only products made specifically for that purpose. Always follow the manufacturer's instructions when using.
- Do not use cleaners that contain hydrochloric, formic, acetic, or phosphoric acids, as these will cause considerable damage to finishes and to plastic components.
- Never mix cleaning materials.
- Never use cleaners containing abrasives. Do not use abrasive cleaning cloths, pads, or sponges.

### Cleaning Procedures

- Clean your faucets and shower products as and when required. Regular cleaning will prevent scale buildup and water spotting.
- Follow the label instructions. Do not allow any cleaner to remain on the product for longer than necessary.
- When using spray cleaners, spray first onto a sponge or cloth – do not spray directly onto the product.
- After cleaning, rinse thoroughly with clear water to remove any cleaner residue.

### Important

- Soap and shampoo residue can also cause damage to the product. Rinse well with clean water after use.
- If the surface is already damaged, harsh cleaning materials will cause further damage.

## Limited Lifetime Consumer Warranty

This product has been manufactured and tested to the highest quality standards by Hansgrohe, Inc. ("Hansgrohe"). This warranty is limited to Hansgrohe products which are purchased by a consumer in the United States after March 1, 1996, and installed in either the United States or Canada.

### WHO IS COVERED BY THE WARRANTY

This warranty extends to the original consumer purchaser only.

### WHAT IS COVERED BY THE WARRANTY

This warranty covers only your Hansgrohe manufactured product. Hansgrohe warrants this product against defects in material or workmanship as follows: Hansgrohe will repair at no charge for parts only or, at its option, replace any product or part of the product which proves defective because of improper workmanship and/or material, under normal installation, use, service and maintenance. If Hansgrohe is unable to provide a replacement and repair is not practical or cannot be timely made, Hansgrohe may elect to refund the purchase price in exchange for the return of the product.

### LENGTH OF WARRANTY

Replacement or repaired parts of products will be covered for the term of this warranty as stated in the following two sentences. If you are a consumer who purchased the product for use primarily for personal, family, or household purposes, this warranty extends for as long as you own the product and the home in which the product is installed. If you purchased the product for use primarily for any other purpose, including, without limitation, a commercial purpose, this warranty extends only (i) for 1 year, with respect to Interaktiv and Retroaktiv products, and (ii) for 5 years, with respect to AXOR, ShowerPower and Pharo products.

THIS WARRANTY DOES NOT COVER, AND HANSGROHE WILL NOT PAY FOR:

- A. Conditions, malfunctions or damage not resulting from defects in material or workmanship.
- B. Conditions, malfunctions or damage resulting from (1) improper installation, improper maintenance, misuse, abuse, negligence, accident or alteration, or (2) the use of abrasive or caustic cleaning agents or "no rinse" cleaning products, or the use of the product in any manner contrary to the product instructions.
- C. Labor or other expenses for the disconnection or return of the product for warranty service, or for installation or reinstallation of the product.
- D. Accessories or related products not manufactured by Hansgrohe.

TO OBTAIN WARRANTY SERVICE

Contact your Hansgrohe retailer, or write to Technical Service at:

Hansgrohe Inc.  
1492 Bluegrass Lakes Parkway  
Alpharetta GA 30004

Or, call Hansgrohe toll-free at (800) 334-0455.

In requesting warranty service, you will need to provide

- 1. The sales receipt or other evidence of the date and place of purchase.
- 2. A description of the problem.
- 3. Delivery of the product or the defective part, postage prepaid and carefully packed and insured, to Hansgrohe Inc. 1492 Bluegrass Lakes Parkway, Alpharetta, Georgia 30004, Attention: Technical Service, if required by Hansgrohe.

When warranty service is completed, any repaired or replacement product or part will be returned to you postage prepaid.

EXCLUSIONS AND LIMITATIONS

REPAIR OR REPLACEMENT (OR, IN LIMITED CIRCUMSTANCES, REFUND OF THE PURCHASE PRICE) AS PROVIDED UNDER THIS WARRANTY IS THE EXCLUSIVE REMEDY OF THE PURCHASER. HANSGROHE NEITHER ASSUMES NOR AUTHORIZES ANY PERSON TO CREATE FOR IT ANY OBLIGATION OR LIABILITY IN CONNECTION WITH THIS PRODUCT.

HANSGROHE SHALL NOT BE LIABLE TO PURCHASER OR ANY PERSON FOR ANY INCIDENTAL, SPECIAL, OR CONSEQUENTIAL DAMAGES, ARISING OUT OF BREACH OF THIS WARRANTY OR ANY IMPLIED WARRANTY (INCLUDING MERCHANTABILITY).

Some States do not allow the exclusion or limitation of incidental or consequential damages, so the above limitation or exclusion may not apply to you.

This warranty gives you specific legal rights, and you may have other rights which vary from State to State.

You may be required by law to give us a reasonable opportunity to correct or cure any failure to comply before you can bring any action in court against us under the Magnuson-Moss Warranty Act.

PRODUCT INSTRUCTIONS AND QUESTIONS

Upon purchase or prior to installation, please carefully inspect your Hansgrohe product for any damage or visible defect. Prior to installing, always carefully study the enclosed instructions on the proper installation and the care and maintenance of the product. If you have questions at any time about the use, installation, or performance of your Hansgrohe product, or this warranty, please call or write to us at the toll-free number and address printed above.

**hansgrohe**

Hansgrohe, Inc. • 1490 Bluegrass Lakes Parkway • Alpharetta, GA 30004  
Tel. 770 360-9880 • Fax 770 360 9887

**[www.hansgrohe-USA.com](http://www.hansgrohe-USA.com)**