



HEATING &amp; AIR CONDITIONING

## TECHNICAL GUIDE

### MODULAR PSC AIR HANDLERS

### FOR USE WITH SPLIT-SYSTEM COOLING & HEAT PUMPS

### MODELS: MP SERIES



Due to continuous product improvement, specifications are subject to change without notice.

Visit us on the web at:

[www.upgnet.com](http://www.upgnet.com) and [www.colemanac.com](http://www.colemanac.com)

Additional rating information can be found at:

[www.ahridirectory.org](http://www.ahridirectory.org)

#### WARRANTY SUMMARY

Standard 5-year limited parts warranty.

**Extended 10-year limited parts warranty** when product is registered online within 90 days of purchase for replacement or closing for new home construction.

## DESCRIPTION

This fan coil line offers the ultimate in application flexibility. This unit may be used for upflow, downflow, horizontal right, or horizontal left applications.

All JCI Unitary Products air handlers and coils can use a TXV to provide our customers with the optimum performance and refrigerant control. Air handlers are shipped with "Flex-coils" without a factory installed metering device. For added flexibility, an R-22 or R-410A TXV or orifice must be field installed to meet the requirement of the desired refrigerant.

## FEATURES

### COMMON MP AIR HANDLER AND CM COIL FEATURES

**RC<sup>2</sup>** - Rigid Case Construction interior endoskeleton for structural support, flush side, and locks in insulation.

**Powder-painted** - G30 galvanized steel case provide a coated edge that resists corrosion and rust creep.

**Quality Construction** - Structural components are made of Aluminum or G90 galvanized steel to prevent corrosion.

**Improved Insulation Design** - Single piece with no external screws to reduce thermal transmission paths to prevent sweating. Foil faced insulation for ease of cleaning.

**Case Depth** - These models have 20.5" casing which provide ease of attic access and tight applications.

### MP AIR HANDLERS

**Factory Sealed** - Achieves 2% or less total airflow leakage rate at duct leakage test conditions in positive and negative pressure for system airflow verification.

**Enhanced Filter Rack** - All models have integrated internal filter racks provided for use with 1" thick standard size filters.

**Electric Heat Kits** - 6HK series of field installed electric heat kits are available for installation-friendly and easy service applications.

**Blowers** - All models use direct-drive, multi-speed PSC motors.

### CM COILS

**MaxAlloy™ Coil** - Long life aluminum coils built to deliver lasting performance, efficiency and reliability.

**Thermostatic Expansion Valve** - The accessory bolt-on TXV provides easy installation to convert the indoor coil to the required refrigerant that does not require brazing to replace or install. Some models are available with factory installed TXV.

**Thermoset Drain Pan** - Positive slope for drainage to reduce cause for potential mold or contaminants.

**Accessories** - A full line of matching accessories available for use with the blower and coils to allow any type application.

**LIST OF SECTIONS**

DESCRIPTION .....	1
FEATURES .....	1
MP AIR HANDLERS .....	1
CM COILS .....	1
NOMENCLATURE .....	2
DIMENSIONS & DUCT CONNECTION DIMENSIONS .....	3
DIMENSIONS - MP MODULAR AIR HANDLERS & CM MULTI-POSITION FULL CASED COILS .....	3
COOLING CAPACITY .....	4
PHYSICAL & ELECTRICAL DATA - COOLING ONLY .....	5
ELECTRICAL DATA - COOLING ONLY .....	5
ELECTRIC HEAT - MINIMUM FAN SPEED .....	6
ELECTRIC HEAT PERFORMANCE DATA: 208/230-1-60 .....	6
ELECTRICAL DATA FOR SINGLE SOURCE POWER SUPPLY: 208/230-1-60 .....	7
ELECTRICAL DATA FOR MULTI-SOURCE POWER SUPPLY: 208/230-1-60 .....	8
kW & MBH CONVERSIONS - FOR TOTAL POWER INPUT REQUIREMENT .....	8
APPLICATION FACTORS - RATED CFM VS. ACTUAL CFM .....	8
POWER WIRING - LINE CONNECTIONS .....	8
BLOWER SPEED CONNECTIONS .....	9
ACCESSORIES .....	9
FILTER RACK DIMENSIONS .....	9
COMBUSTIBLE FLOOR BASE ACCESSORY .....	10
LIMITATIONS .....	10
TYPICAL APPLICATIONS .....	10
TYPICAL THERMOSTAT CONNECTION .....	11
AIR FLOW DATA - CFM (208 Volt) .....	12
AIR FLOW DATA - CFM (230 Volt) .....	13
WIRING DIAGRAM .....	14

**NOMENCLATURE**

<b>PRODUCT TYPE</b>	<b>M</b>	<b>M</b> = Modular Blower
<b>POSITION MOTOR TYPE</b>	<b>P</b>	<b>P</b> = Multi PSC <b>E</b> = Multi Std ECM <b>V</b> = Multi VS ECM
<b>OPTIONS</b>	<b>-</b>	<b>C</b> = Communications Ready - (No Designator) = Standard (No Options)
<b>NOMINAL AIR FLOW</b>	<b>12</b>	<b>08</b> = 800 CFM <b>12</b> = 1,200 CFM <b>14</b> = 1,400 CFM <b>16</b> = 1,600 CFM <b>20</b> = 2,000 CFM
<b>CABINET WIDTH</b>	<b>B</b>	<b>A</b> = 14.5" <b>B</b> = 17.5" <b>C</b> = 21.0" <b>D</b> = 24.5"
<b>OPTIONS</b>	<b>N</b>	<b>N</b> = No options
<b>VOLTAGE (Voltage-Phase-Hertz)</b>	<b>2</b>	<b>1</b> = 115-1-60 <b>3</b> = 208/230-3-60 <b>2</b> = 208/230-1-60 <b>4</b> = 460-3-60
<b>GENERATION (MAJOR REVISION)</b>	<b>1</b>	<b>1</b> = 1st Gen <b>2</b> = 2nd Gen etc.
<b>STYLE LETTER (MINOR REVISION) NOT USED FOR ORDERING</b>	<b>A</b>	<b>A</b> = Style A <b>B</b> = Style B etc.

**DIMENSIONS & DUCT CONNECTION DIMENSIONS**

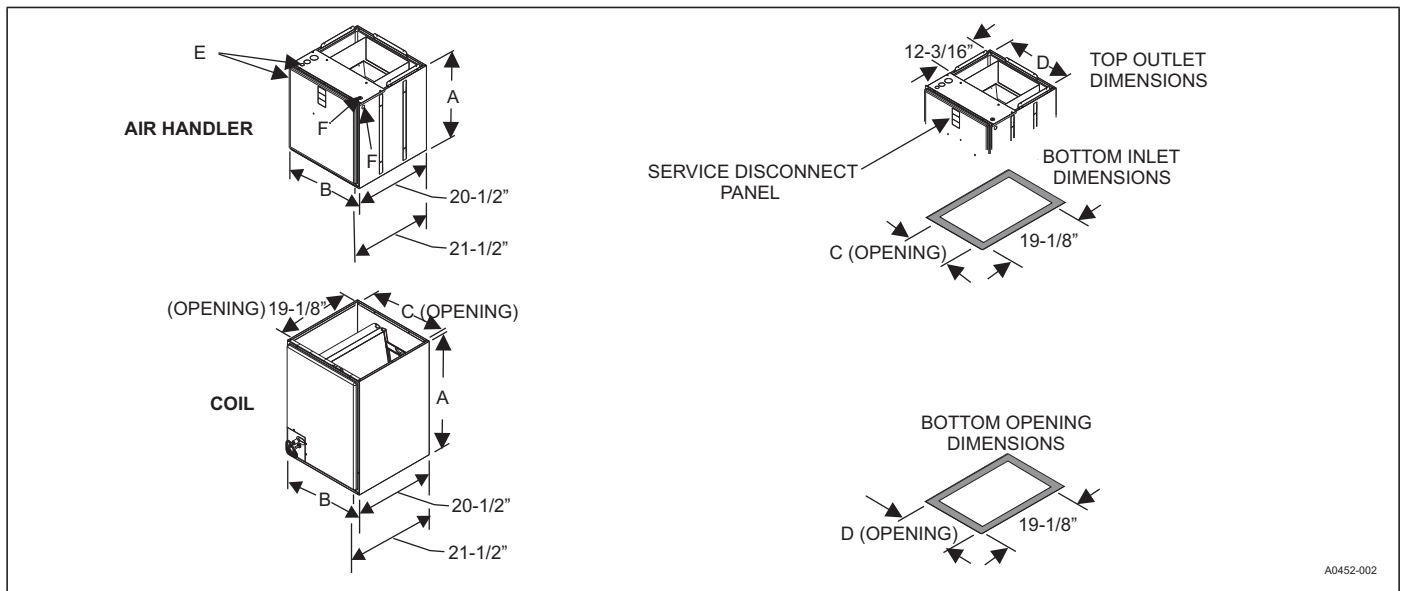

**DIMENSIONS - MP MODULAR AIR HANDLERS & CM MULTI-POSITION FULL CASED COILS**

Models	Dimensions <sup>1</sup>					Wiring Knockouts	
	Height	Width	Opening Widths		E	F	
	A	B	C	D	Power	Control	
MP08BN21	21-1/2	17-1/2	16-1/2	16-1/2	7/8 (1/2), 1-3/8 (1), 1-23/32 (1-1/4)	7/8 (1/2)	
MP12BN21	21-1/2	17-1/2	16-1/2	16-1/2			
MP14DN21	22-1/2	24-1/2	23-1/2	23-1/2			
MP16CN21	22-1/2	21	20	20			
MP20DN21	22-1/2	24-1/2	23-1/2	23-1/2			
Models	Dimensions <sup>1</sup>					Refrigerant Connections <sup>2</sup>	
	Height	Width	Opening Widths		Line Size		
	A	B	C	D	Liquid	Vapor	
CM18A	19-1/2	14-1/2	13-1/2	13-1/2	3/8	3/4	
CM18B	19	17-1/2	16-1/2	16-1/2			
CM24A	19-1/2	14-1/2	13-1/2	13-1/2			
CM24B	19	17-1/2	16-1/2	16-1/2			
CM24C	21	21	20	20			
CM30A	25-1/2	14-1/2	13-1/2	13-1/2			
CM30B	23	17-1/2	16-1/2	16-1/2			
CM30C	23	21	20	20			
CM30D	25	24-1/2	23-1/2	23-1/2			
CM36A	25-1/2	14-1/2	13-1/2	13-1/2			
CM36B	25-5/8	17-1/2	16-1/2	16-1/2			
CM36C	25	21	20	20			
CM36D	25	24-1/2	23-1/2	23-1/2			
CM42C	27	21	20	20			
CM42D	27	24-1/2	23-1/2	23-1/2			
CM48C	33	21	20	20	7/8		
CM48D	32-3/4	24-1/2	23-1/2	23-1/2			
CM60C	33	21	20	20			
CM60D	32-3/4	24-1/2	23-1/2	23-1/2			
CM64D	32-3/4	24-1/2	23-1/2	23-1/2			

1. All dimensions are in inches as actual size (Dimensions in parenthesis are Conduit size).  
 2. Refrigerant line sizes may require larger lines for extended line lengths. See York bulletin #690.01-AD1V for details.

**COOLING CAPACITY<sup>1</sup>**

Models	Rated CFM <sup>2</sup>	Entering Air Dry/Wet Bulb (°F)	MBH@ Evap. Temp. and Corresponding R-410A Pressure (°F/PSIG)			
			35/107.9	40/118.9	45/130.7	50/143.3
CM18B	600	85/72	45.7	41.6	36.8	30.5
		80/67	38.5	33.9	28.5	22.3
		75/62	31.5	26.5	20.5	15.9
		70/57	24.4	19.5	15.2	11.5
CM24B	800	85/72	52.2	47.5	41.8	35.0
		80/67	43.6	38.3	31.9	24.5
		75/62	35.2	29.5	22.7	16.2
		70/57	27.1	20.7	15.5	11.4
CM24C	800	85/72	52.2	47.5	41.8	35.0
		80/67	43.6	38.3	31.9	24.5
		75/62	35.2	29.5	22.7	16.2
		70/57	27.1	20.7	15.5	11.4
CM30B	1000	85/72	75.3	67.8	56.8	47.1
		80/67	62.6	54.6	44.2	34.5
		75/62	50.2	41.3	32.0	22.9
		70/57	37.8	30.1	21.5	16.2
CM30C	1000	85/72	75.3	67.8	56.8	47.1
		80/67	62.6	54.6	44.2	34.5
		75/62	50.2	41.3	32.0	22.9
		70/57	37.8	30.1	21.5	16.2
CM30D	1000	85/72	75.3	67.8	56.8	47.1
		80/67	62.6	54.6	44.2	34.5
		75/62	50.2	41.3	32.0	22.9
		70/57	37.8	30.1	21.5	16.2
CM36B	1000	85/72	82.1	73.7	64.1	54.4
		80/67	68.6	60.1	50.5	39.5
		75/62	56.3	47.0	37.3	29.2
		70/57	43.5	36.0	28.3	21.6
CM36B	1200	85/72	91.6	82.4	71.3	59.4
		80/67	76.5	65.4	54.6	42.8
		75/62	61.3	51.2	40.0	30.5
		70/57	47.5	38.1	28.7	22.3
CM42C	1200	85/72	98.0	88.6	77.4	66.4
		80/67	82.6	72.6	61.7	50.6
		75/62	68.5	57.6	47.5	36.6
		70/57	53.9	44.8	35.0	28.4
CM36C	1200	85/72	91.6	82.4	71.3	59.4
		80/67	76.5	65.4	54.6	42.8
		75/62	61.3	51.2	40.0	30.5
		70/57	47.5	38.1	28.7	22.3
CM36D	1200	85/72	91.6	82.4	71.3	59.4
		80/67	76.5	65.4	54.6	42.8
		75/62	61.3	51.2	40.0	30.5
		70/57	47.5	38.1	28.7	22.3
CM42C	1400	85/72	100.6	89.8	78.2	64.7
		80/67	83.5	73.7	59.8	48.0
		75/62	67.8	55.8	44.7	32.5
		70/57	52.3	41.5	30.7	23.7
CM42D	1400	85/72	100.6	89.8	78.2	64.7
		80/67	83.5	73.7	59.8	48.0
		75/62	67.8	55.8	44.7	32.5
		70/57	52.3	41.5	30.7	23.7

For notes, see Page 5.

**COOLING CAPACITY<sup>1</sup> (Continued)**

Models	Rated CFM <sup>2</sup>	Entering Air Dry/Wet Bulb (°F)	MBH@ Evap. Temp. and Corresponding R-410A Pressure (°F/PSIG)			
			35/107.9	40/118.9	45/130.7	50/143.3
CM48C	1400	85/72	108.0	98.4	88.1	73.8
		80/67	93.3	82.1	69.7	57.0
		75/62	75.9	64.4	53.1	41.9
		70/57	60.7	49.9	39.4	32.4
CM48C	1600	85/72	115.2	105.0	93.9	79.0
		80/67	88.3	78.2	65.5	52.6
		75/62	72.7	60.8	50.1	37.6
		70/57	57.7	46.9	36.6	29.7
CM48D	1600	85/72	115.2	105.0	93.9	79.0
		80/67	88.3	78.2	65.5	52.6
		75/62	72.7	60.8	50.1	37.6
		70/57	57.7	46.9	36.6	29.7
CM60C	1800	85/72	115.1	103.0	91.7	78.6
		80/67	96.8	85.9	73.7	60.5
		75/62	80.7	69.4	57.5	43.5
		70/57	58.7	48.9	37.7	32.7
CM60D	1800	85/72	115.1	103.0	91.7	78.6
		80/67	96.8	85.9	73.7	60.5
		75/62	80.7	69.4	57.5	43.5
		70/57	58.7	48.9	37.7	32.7
CM64D	1800	85/72	133.6	118.5	103.2	86.6
		80/67	111.4	96.2	80.3	62.8
		75/62	90.7	75.1	60.0	43.5
		70/57	70.6	56.9	42.5	32.8

1. See Condensing Unit or Heat Pump Technical Guide for Total Cooling Capacity and Sensible Capacity.
2. Airflow is calculated for each system tonnage.

**PHYSICAL & ELECTRICAL DATA - COOLING ONLY**

Models	MP08B	MP12B	MP14D	MP16C	MP20D	
Blower - Diameter x Width	10 x 8	10 x 8	10 x 10	10 x 10	10 x 10	
Motor	HP	1/4 HP	1/2 HP	1/2 HP	1 HP	
	Nominal RPM	850	1085	1085	1040	1007
Voltage	208/230	208/230	208/230	208/230	208/230	
Full Load Amps @230V	1.4	2.6	2.8	2.9	4.1	
Filter <sup>1</sup>	Type	DISPOSABLE OR PERMANENT				
	Size	16 x 20 x 1	16 x 20 x 1	22 x 20 x 1	20 x 20 x 1	22 x 20 x 1
	Bottom Rack Kit	1BR01117	1BR01117	1BR01124	1BR01121	1BR01124
	Permanent Type Kit	1PF0601	1PF0601	1PF0603	1PF0602	1PF0603
Shipping / Operating Weight (lbs.)	52/51	52/51	75/74	68/67	75/74	

1. Field Supplied.

**ELECTRICAL DATA - COOLING ONLY**

Models	Motor FLA <sup>1</sup>	Minimum Circuit Ampacity	MOP <sup>2</sup>
MP08B	1.4	1.8	15
MP12B	2.6	3.3	
MP14D	2.8	3.5	
MP16C	2.9	3.6	
MP20D	4.1	5.1	

1. FLA = Full Load Amps.
2. MOP = Maximum Overcurrent Protection device; must be HACR type circuit breaker or time delay fuse. Refer to the latest edition of the National Electric Code or in Canada the Canadian electrical Code and local codes to determine correct wire sizing.

**ELECTRICAL HEAT - MINIMUM FAN SPEED**

Heater Kit Models <sup>1,2</sup>	Nom. kW @240V	Air Handler Models				
		MP08B	MP12B	MP14D	MP16C	MP20D
6HK(0,1)6500206	2.4	Low	Low	Low	Low	Low
6HK(0,1)6500506	4.8	Low	Low	Low	Low	Low
6HK(0,1)6500806	7.7	Low	Low	Low	Low	Low
6HK(0,1)6501006	9.6	Low	Low	Low	Low	Low
6HK(1,2)6501306	12.5	Med	Low	Low	Low	Low
6HK(1,2)6501506	14.4	–	Med	Low	Low	Low
6HK(1,2)6501806	17.3	–	Med	Low	Low	Low
6HK(1,2)6502006	19.2	–	Med	Med	High	Low

1. (0,1) - 0 = no circuit breaker OR 1 = with circuit breaker.

2. (1,2) - 1 = with circuit breaker, no breaker jumper bar OR 2 = with circuit breaker & breaker jumper bar.

**ELECTRIC HEAT PERFORMANCE DATA: 208/230-1-60**

Heater Models <sup>1,2</sup>		Nominal kW @240V	Total Heat <sup>3</sup>				kW Staging			
			kW		MBH		W1 Only		W1 + W2	
			208V	230V	208V	230V	208V	230V	208V	230V
1PH	6HK(0,1)6500206	2.4	1.8	2.2	6.2	7.5	1.8	2.2	1.8	2.2
	6HK(0,1)6500506	4.8	3.6	4.4	12.3	15	3.6	4.4	3.6	4.4
	6HK(0,1)6500806	7.7	5.8	7.1	19.7	24.1	5.8	7.1	5.8	7.1
	6HK(0,1)6501006	9.6	7.2	8.8	24.6	30.1	7.2	8.8	7.2	8.8
	6HK(1,2)6501306	12.5	9.4	11.5	32	39.2	3.1	3.8	9.4	11.5
	6HK(1,2)6501506	14.4	10.8	13.2	36.9	45.1	3.6	4.4	10.8	13.2
	6HK(1,2)6501806	17.3	13	15.9	44.3	54.2	6.5	7.9	13	15.9
	6HK(1,2)6502006	19.2	14.4	17.6	49.2	60.2	7.2	8.8	14.4	17.6

1. (0,1) - 0 = no service disconnect OR 1 = with service disconnect.

2. (1,2) - 1 = with service disconnect, no breaker jumper bar OR 2 = with service disconnect & breaker jumper bar.

3. For different power distributions, see conversion table on Page 4.

**ELECTRICAL DATA FOR SINGLE SOURCE POWER SUPPLY: 208/230-1-60**

Air Handler Models	Heater Models <sup>1,2</sup>	Heater Amps @240V	Field Wiring			
			Min. Circuit Ampacity		MOP. <sup>3</sup>	
			208V	230V	208V	230V
MP08B	6HK(0,1)6500206	10	12.6	13.7	15	15
	6HK(0,1)6500506	20	23.4	25.7	25	30
	6HK(0,1)6500806	32	36.6	40.3	40	45
	6HK(0,1)6501006	40	45.0	49.6	45	50
	6HK(1,2)6501306	52	58.2	64.3	60	70
MP12B	6HK(0,1)6500206	10	14.1	15.2	15	20
	6HK(0,1)6500506	20	24.9	27.2	25	30
	6HK(0,1)6500806	32	38.1	41.8	40	45
	6HK(0,1)6501006	40	46.5	51.1	50	60
	6HK(1,2)6501306	52	59.7	65.8	60	70
	6HK(1,2)6501506	60	68.2	75.0	70	80
	6HK(1,2)6501806	72	81.4	89.7	90	90
MP14D	6HK(0,1)6500206	10	14.3	15.5	15	20
	6HK(0,1)6500506	20	25.1	27.4	30	30
	6HK(0,1)6500806	32	38.4	42.1	40	45
	6HK(0,1)6501006	40	46.8	51.3	50	60
	6HK(1,2)6501306	52	60.0	66.0	60	70
	6HK(1,2)6501506	60	68.4	75.2	70	80
	6HK(1,2)6501806	72	81.6	89.9	90	90
MP16C	6HK(0,1)6500206	10	14.4	15.6	15	20
	6HK(0,1)6500506	20	25.3	27.5	30	30
	6HK(0,1)6500806	32	38.5	42.2	40	45
	6HK(0,1)6501006	40	46.9	51.5	50	60
	6HK(1,2)6501306	52	60.1	66.1	70	70
	6HK(1,2)6501506	60	68.5	75.4	70	80
	6HK(1,2)6501806	72	81.8	90.0	90	90
MP20D	6HK(0,1)6500206	10	15.9	17.1	20	20
	6HK(0,1)6500506	20	26.8	29.0	30	30
	6HK(0,1)6500806	32	40.0	43.7	40	45
	6HK(0,1)6501006	40	48.4	53.0	50	60
	6HK(1,2)6501306	52	61.6	67.6	70	70
	6HK(1,2)6501506	60	70.0	76.9	70	80
	6HK(1,2)6501806	72	83.3	91.5	90	100
	6HK(1,2)6502006	80	91.7	100.8	100	110

1. (0,1) - 0 = no service disconnect OR 1 = with service disconnect.

2. (1,2) - 1 = with service disconnect, no breaker jumper bar OR 2 = with service disconnect & breaker jumper bar.

3. MOP = Maximum Overcurrent Protection device; must be HACR type circuit breaker or time delay fuse. The 1st circuit includes blower motor amps. Refer to the latest edition of the National Electric Code or in Canada the Canadian electrical Code and local codes to determine correct wire sizing.

**ELECTRICAL DATA FOR MULTI-SOURCE POWER SUPPLY: 208/230-1-60**

Air Handler Models	Heater Models <sup>1,2</sup>	Heater Amps @240V	Min. Circuit Ampacity				MOP. <sup>3</sup>			
			208V		230V		208V		230V	
			Circuit				Circuit			
			1st	2nd	1st <sup>3</sup>	2nd	1st <sup>3</sup>	2nd	1st <sup>3</sup>	2nd
MP08B	6HK16501306	52	20.5	37.6	22.5	41.5	25	40	25	45
MP12B	6HK16501306	52	22.0	37.6	24.0	41.5	25	40	25	45
	6HK16501506	60	24.9	43.3	27.2	47.9	25	45	30	50
	6HK16501806	72	42.3	39.0	46.4	43.1	45	40	50	45
	6HK16502006	80	46.6	43.3	51.2	47.9	50	45	60	50
MP14D	6HK16501306	52	22.3	37.6	24.3	41.5	25	40	25	45
	6HK16501506	60	25.2	43.3	27.5	47.9	30	45	30	50
	6HK16501806	72	29.5	39.0	46.6	43.1	30	40	50	45
	6HK16502006	80	32.4	43.3	51.4	47.9	35	45	60	50
MP16C	6HK16501306	52	22.4	37.6	24.4	41.5	25	40	25	45
	6HK16501506	60	25.3	43.3	27.6	47.9	30	45	30	50
	6HK16501806	72	42.6	39.0	46.8	43.1	30	40	50	45
	6HK16502006	80	47.0	43.3	51.5	47.9	35	45	60	50
MP20D	6HK16501306	52	23.9	37.6	25.9	41.5	25	40	30	45
	6HK16501506	60	26.8	43.3	29.1	47.9	30	45	30	50
	6HK16501806	72	44.1	39.0	48.3	43.1	45	40	50	45
	6HK16502006	80	48.5	43.3	53.0	47.9	50	45	60	50

- (0,1) - 0 = no service disconnect OR 1 = with service disconnect.
- (1,2) - 1 = with service disconnect, no breaker jumper bar OR 2 = with service disconnect & breaker jumper bar.
- MOP = Maximum Overcurrent Protection device; must be HACR type circuit breaker or time delay fuse. The 1st circuit includes blower motor amps. Refer to the latest edition of the National Electric Code or in Canada the Canadian electrical Code and local codes to determine correct wire sizing.

**KW & MBH CONVERSIONS - FOR TOTAL POWER INPUT REQUIREMENT**

For a power distribution voltage that is different than the provided nominal voltage, multiply the kW and MBH data from the table by the conversion factor in the following table.

DISTRIBUTION POWER	NOMINAL VOLTAGE	CONVERSION FACTOR
208V	240V	0.75
220V	240V	0.84
230V	240V	0.92

**APPLICATION FACTORS - RATED CFM VS. ACTUAL CFM**

% Of Rated Airflow (CFM)	80%	90%	100%	110%	120%
Capacity Factor	0.96	0.98	1.00	1.02	1.03

**POWER WIRING - LINE CONNECTIONS**

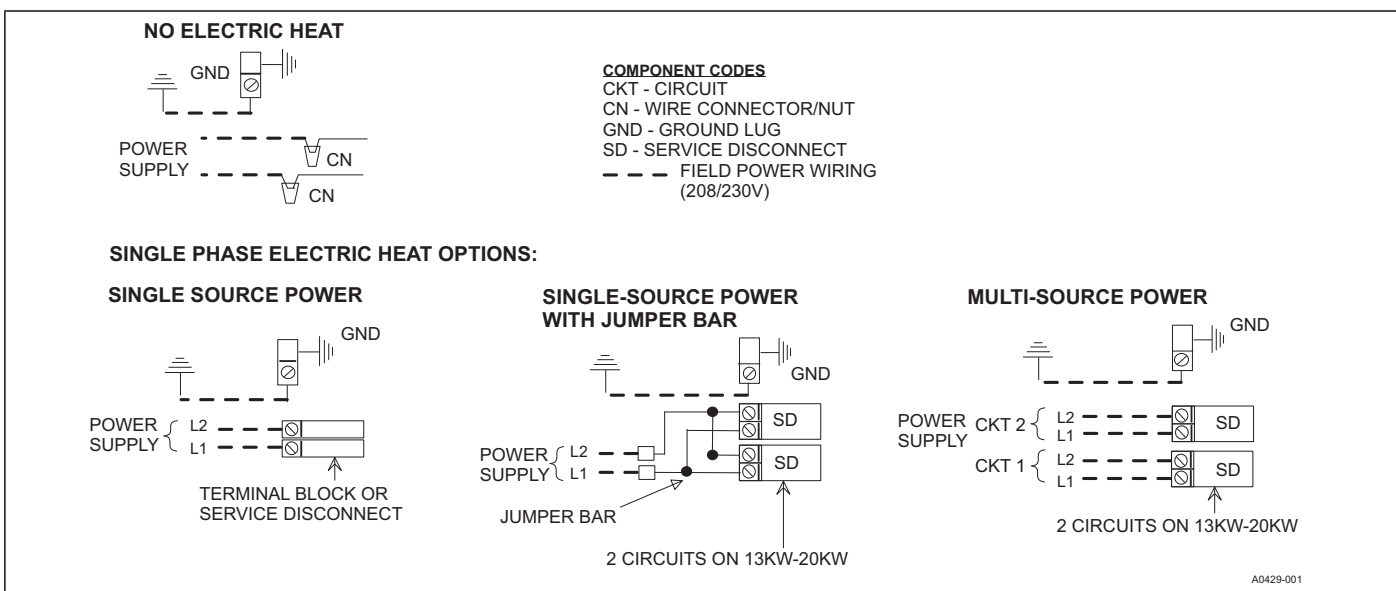



**BLOWER SPEED CONNECTIONS**

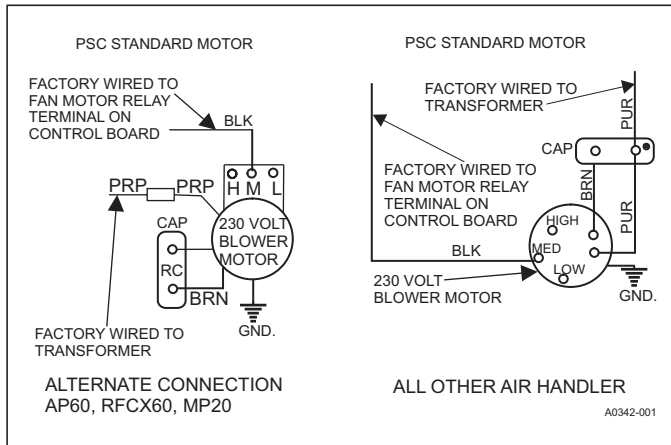

**ACCESSORIES**

Refer to Price Manual for specific model numbers where not shown.

**TXV Kits** - Air handlers are shipped with “Flex-coils” without a factory installed metering device. For added flexibility, an R-22 or R-410A TXV or orifice can be field installed to meet your refrigerant choice. All kits are bolt-on and require no brazing to install.

**Electric Heaters** - 6HK models shown under electrical data include sequential operation and temperature dual limit switches for safe, efficient operation. Service disconnects are provided where shown.

**Bottom Rack Filter Kit** - The filter frame accessory allows installation of an external air handler filter in an upflow application, a downflow application, or a horizontal application (refer to the following illustration/table for Filter Rack Dimensions).

**FILTER RACK DIMENSIONS**

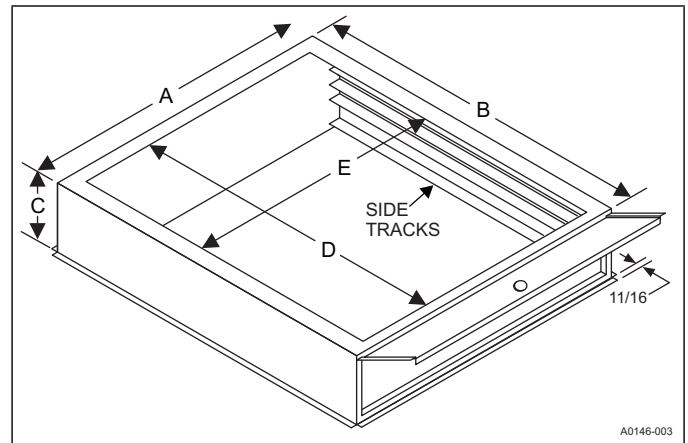

Galvanized Models	A	B	C	D	E	Filter Size
1BR01117	17.50	21.56	4.00	18.63	14.25	16 x 20 x 1 or 2
1BR01121	21.00	21.56	4.00	18.63	17.75	20 x 20 x 1 or 2
1BR01124	24.50	21.56	4.00	18.63	21.25	20 x 24 x 1 or 2

**Note:** Filters - Not supplied with kit.

**NOTICE**

*Filter frames are orientation specific. The block-off box provided with the kit is to be inserted after the air filter has been installed.*

For upflow platform return applications, cut the hole in the return air platform the same size as the filter frame opening (dimensions for E x D in Table 1). DO NOT cut an oversized hole.

**NOTICE**

*When attaching return air duct system to filter frame, mounting hardware should not have sharp extruding points exposed.*

**Combustible Floor Base Accessory** - If an electric heat accessory which is rated for greater than zero clearance to combustible surfaces is installed in these air handlers in the downflow operating positions on a combustible floor, one of the following combustible floor base accessory models is required: S1-1FB1917, S1-1FB1921, S1-1FB1924.

**Breaker Moisture Seal Accessory** - A clear circuit breaker moisture barrier seals the breakers from humidity and dust. The flexibility of the clear cover allows circuit breakers to be turned ON or OFF without removing the cover. The cover firmly attaches to the access panel around the circuit breakers with the use of double backed adhesive tape. To ensure that moisture or dust does not contaminate circuit breakers, an S1-02435672000, Circuit Breaker, Cover Seal may be ordered.

**COMBUSTIBLE FLOOR BASE ACCESSORY**

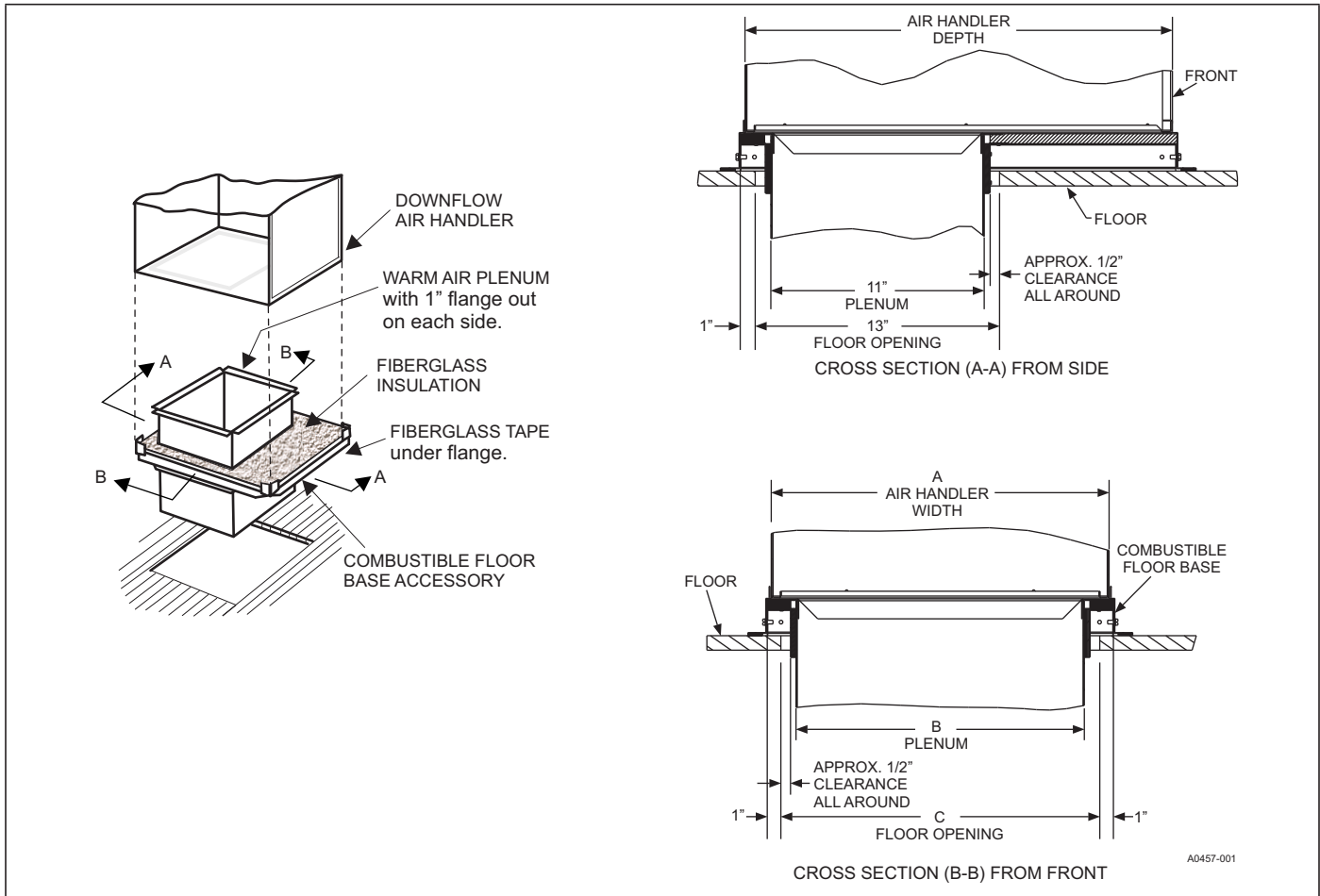

Floor Base Models	Used with	Dimensions		
		A	B	C
1FB1917	MP08B, MP12B	17.5	14.0	16.0
1FB1921	MP16C	21.0	17.5	19.5
1FB1924	MP14D, MP20D	24.5	21.0	23.0

**LIMITATIONS**

These units must be wired and installed in accordance with all national and local safety codes.

Voltage limits are as follows:

Air Handler Voltage	<sup>1</sup> Normal Operating Voltage Range
208/230-1-60	187-253

1. Rated in accordance with ARI Standard 110, utilization range "A".

Airflow must be within the minimum and maximum limits approved for electric heat, evaporator coils and outdoor units.

**TYPICAL APPLICATIONS**

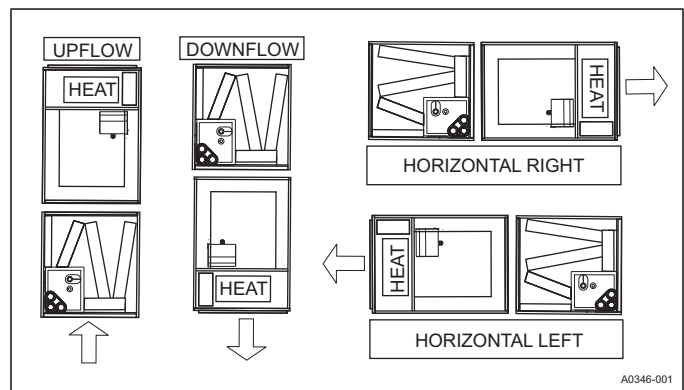

**TYPICAL THERMOSTAT CONNECTION**

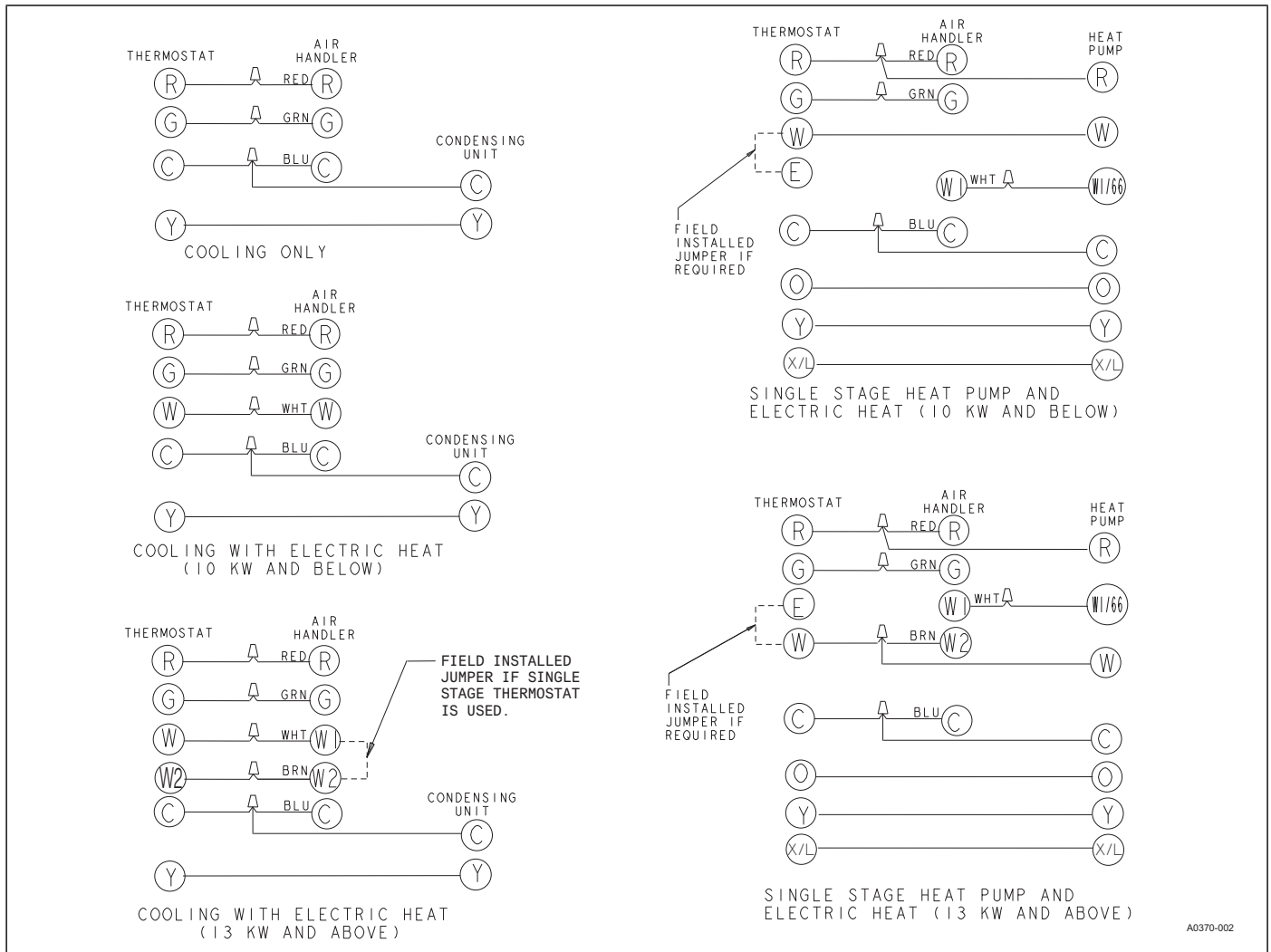

A0370-002

**AIR FLOW DATA - CFM<sup>1</sup> (208 Volt)**

Models	CM Models	Blower Motor Speed	External Static Pressure (in. wc.)						
			0.10	0.20	0.30	0.40	0.50	0.60	0.70
<b>208 Volt</b>									
MP08B	CM18B	High	975	965	953	926	889	772	724
		Medium	729	719	700	643	614	540	354
		Low	576	561	501	455	407	289	209
	CM24B	High	950	944	927	907	876	838	742
		Medium	713	703	686	656	591	533	478
		Low	560	546	511	448	398	294	208
MP12B	CM30B	High	1459	1410	1342	1275	1200	1129	1022
		Medium	1241	1210	1156	1110	1044	1002	917
		Low	992	965	940	911	867	822	758
	CM36B	High	1487	1438	1383	1315	1245	1150	1073
		Medium	1226	1202	1166	1119	1079	1007	945
		Low	959	950	925	892	866	818	716
MP14D	CM30D	High	1944	1891	1832	1767	1693	1594	1303
		Medium	1518	1494	1470	1425	1377	1186	1071
		Low	1208	1198	1180	1155	1019	968	830
	CM36D	High	1967	1920	1848	1781	1710	1623	1532
		Medium	1520	1508	1486	1446	1398	1203	1101
		Low	1207	1202	1176	1156	1028	970	885
	CM42D	High	1949	1912	1854	1791	1715	1645	1358
		Medium	1538	1521	1492	1458	1406	1265	1144
		Low	1197	1190	1179	1128	1052	998	903
MP16C	CM36C	High	1776	1709	1646	1573	1491	1328	1171
		Medium	1591	1545	1486	1424	1300	1173	1066
		Low	1360	1331	1285	1194	1097	1027	941
	CM42C	High	1746	1687	1616	1536	1386	1265	1147
		Medium	1564	1507	1451	1388	1246	1148	998
		Low	1339	1301	1258	1136	1052	994	876
	CM48C	High	1817	1756	1678	1599	1511	1296	1120
		Medium	1673	1618	1542	1477	1349	1138	915
		Low	1448	1419	1362	1281	1136	1001	948
MP20D	CM42D	High	2035	1994	1922	1858	1781	1658	1562
		Medium	1849	1819	1771	1694	1650	1575	1364
		Low	1679	1654	1624	1578	1526	1339	1263
	CM48D	High	2061	2001	1937	1871	1780	1684	1570
		Medium	1867	1835	1786	1727	1653	1563	1328
		Low	1678	1657	1615	1572	1518	1441	1235
	CM60D	High	2021	1979	1897	1833	1751	1668	1521
		Medium	1852	1811	1758	1697	1639	1547	1389
		Low	1646	1630	1596	1555	1491	1384	1247
	CM64D	High	1867	1832	1784	1729	1652	1572	1462
		Medium	1498	1484	1443	1411	1361	1233	1138
		Low	1128	1122	1115	1096	1020	967	893

1. Air handler units have been tested to UL 1995 / CSA 22.2 standards up to 0.50" wc. external static pressure. Dry coil conditions only, tested without filters.

For optimal performance, external static pressures of 0.2" to 0.5" are recommended. Applications above 0.5" are not recommended.

**AIR FLOW DATA - CFM<sup>1</sup> (230 Volt)**

Models	CM Models	Blower Motor Speed	External Static Pressure (in. wc.)						
			0.10	0.20	0.30	0.40	0.50	0.60	0.70
<b>230 Volt</b>									
MP08B	CM18B	High	1142	1126	1093	1057	1009	953	852
		Medium	855	840	826	798	756	696	594
		Low	676	663	638	584	528	482	404
	CM24B	High	1105	1088	1060	1030	987	948	859
		Medium	825	815	802	780	752	678	591
		Low	655	636	616	569	504	467	345
MP12B	CM30B	High	1521	1471	1397	1322	1241	1161	1057
		Medium	1369	1329	1281	1224	1166	1092	1015
		Low	1130	1107	1071	1029	972	910	842
	CM36B	High	1557	1507	1440	1363	1289	1185	1125
		Medium	1351	1321	1266	1207	1153	1076	1019
		Low	1103	1083	1056	1024	976	928	851
MP14D	CM30D	High	2092	2038	1958	1884	1795	1714	1591
		Medium	1725	1697	1634	1598	1534	1454	1179
		Low	1374	1366	1339	1316	1250	1070	904
	CM36D	High	2099	2040	1980	1903	1814	1680	1605
		Medium	1725	1694	1652	1605	1541	1467	1182
		Low	1388	1372	1340	1306	1277	1106	1026
	CM42D	High	2083	2033	1960	1894	1820	1720	1459
		Medium	1690	1662	1623	1587	1534	1460	1233
		Low	1399	1393	1370	1338	1269	1159	1073
MP16C	CM36C	High	1850	1785	1705	1625	1541	1373	1242
		Medium	1693	1642	1574	1499	1378	1261	1145
		Low	1512	1465	1407	1324	1225	1101	1022
	CM42C	High	1815	1754	1680	1593	1472	1278	1206
		Medium	1670	1613	1554	1473	1311	1210	1082
		Low	1488	1445	1376	1259	1181	1056	979
	CM48C	High	1886	1818	1739	1646	1567	1348	1163
		Medium	1742	1683	1622	1538	1461	1237	1121
		Low	1563	1512	1455	1399	1234	1086	1019
MP20D	CM42D	High	2123	2076	2001	1926	1840	1744	1439
		Medium	1999	1959	1896	1821	1744	1651	1347
		Low	1851	1819	1768	1698	1626	1544	1269
	CM48D	High	2178	2107	2034	1953	1878	1775	1604
		Medium	2014	1965	1905	1843	1761	1660	1351
		Low	1867	1832	1779	1727	1661	1544	1280
	CM60D	High	2132	2052	1993	1899	1813	1733	1594
		Medium	1985	1941	1872	1798	1729	1648	1507
		Low	1848	1810	1758	1695	1627	1548	1355
	CM64D	High	2069	2011	1929	1848	1755	1651	1402
		Medium	1962	1902	1832	1758	1675	1558	1335
		Low	1833	1787	1734	1667	1581	1382	1269

1. Air handler units have been tested to UL 1995 / CSA 22.2 standards up to 0.50" wc. external static pressure.

Dry coil conditions only, tested without filters.

For optimal performance, external static pressures of 0.2" to 0.5" are recommended. Applications above 0.5" are not recommended.

# WIRING DIAGRAM

WHEN INSTALLING HEATER KIT, BE SURE THE BLOWER SPEED IS SET TO THE SPEED SPECIFIED FOR THE AIR HANDLER/HEATER KIT COMBINATION ON THIS UNIT'S INSTALLATION INSTRUCTIONS.

SEE INSTALLATION INSTRUCTIONS FOR PROPER LOW VOLTAGE FIELD WIRING CONNECTIONS.

HEATER KITS:  
6HK\*6500206  
6HK\*6500506

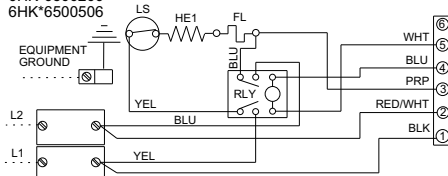

HEATER KITS:  
6HK\*6500806  
6HK\*6501006

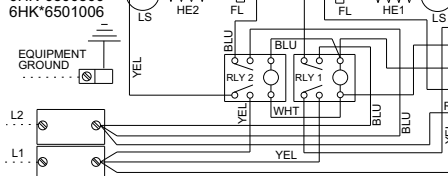

HEATER KITS:  
6HK\*6501306  
6HK\*6501506

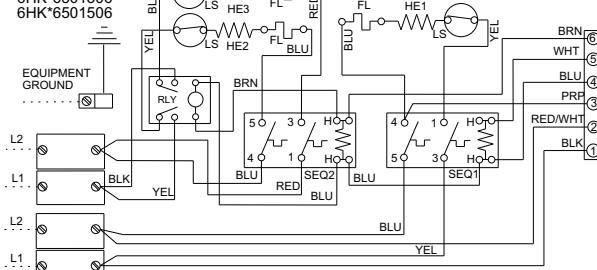

HEATER KITS:  
6HK\*6501806  
6HK\*6502006

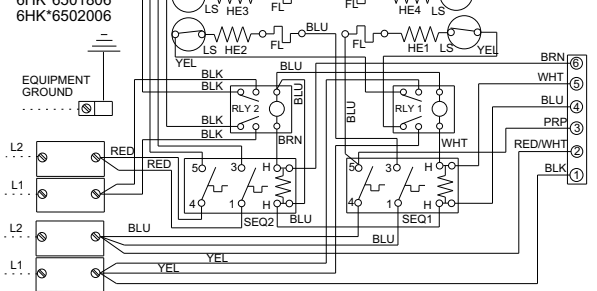

HEATER KIT:  
6HK\*6502506

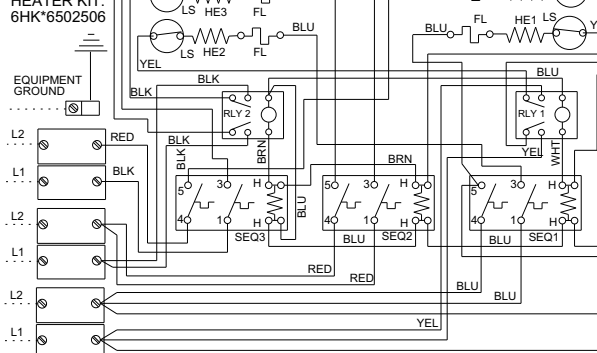

## AIR HANDLER - WITH NO HEAT KIT WIRING DIAGRAM

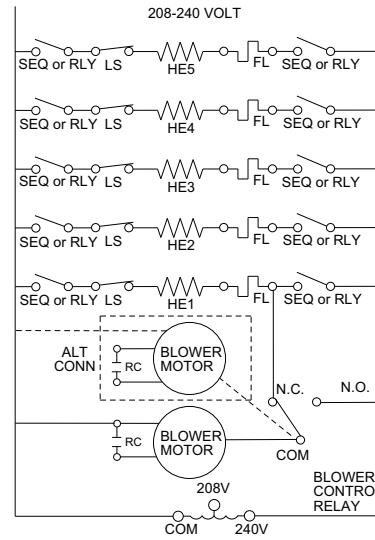

## 208-240 VOLT

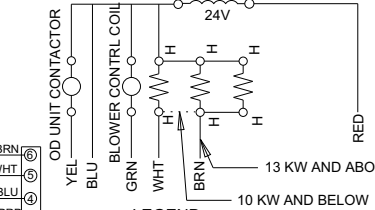

LEGEND  
LS - LIMIT SWITCH  
SEQ - SEQUENCER  
HE - HEATING ELEMENT  
FL - FUSIBLE LINK  
H - SEQUENCER HEATER  
RC - RUN CAPACITOR  
RLY - RELAY

USE COPPER CONDUCTORS ONLY.  
IF ALUMINUM CONDUCTORS ARE PRESENT,  
ALL APPLICABLE LOCAL AND NATIONAL  
CODES MUST BE FOLLOWED.

1199995-UWD-A-0415