

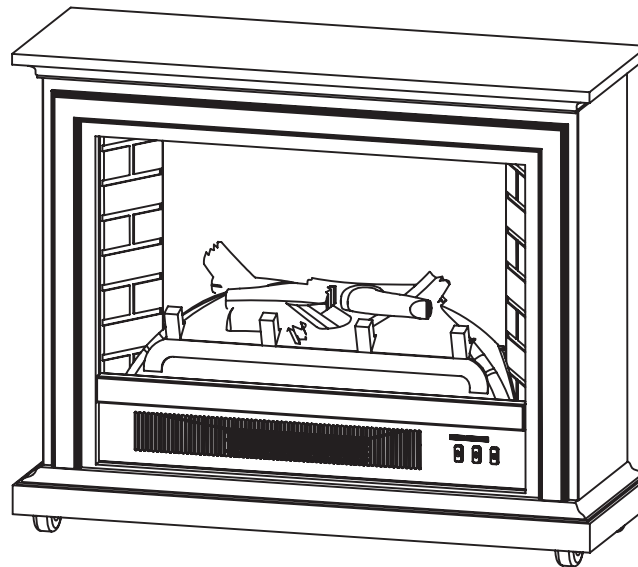

USE AND CARE GUIDE

DERRY ELECTRIC FIREPLACE



IMPORTANT INSTRUCTIONS

PLEASE READ THIS MANUAL BEFORE INSTALLING AND USING APPLIANCE

WARNING!

IF THE INFORMATION IN THIS MANUAL IS NOT FOLLOWED EXACTLY,
AN ELECTRICAL SHOCK OR FIRE MAY RESULT
CAUSING PROPERTY DAMAGE, PERSONAL INJURY OR LOSS OF LIFE.

INSTALLER: Leave this manual with the appliance.
CONSUMER: Retain this manual for future reference.

Questions, problems, missing parts? Before returning to the store,
call Hampton Bay Customer Service
8 a.m. - 6 p.m., EST, Monday - Friday

1-877-527-0313

HAMPTONBAY.COM

THANK YOU

We appreciate the trust and confidence you have placed in Hampton Bay through the purchase of this electric fireplace. We strive to continually create quality products designed to enhance your home. Visit us online to see our full line of products available for your home improvement needs. Thank you for choosing Hampton Bay!



Table of Contents

Table of Contents	2	Operation.....	10
Safety Information	3	Maintenance	11
Warranty	5	Care and Cleaning	12
Pre-Installation.....	6	Troubleshooting	13
Installation	9	Service Parts.....	14



IMPORTANT: Read all instructions and warnings carefully before starting installation. Failure to follow these instructions may result in a possible electric shock, injury to persons, fire hazard and will void the warranty.

Please read the Installation & Operating Instructions before using this appliance.



CAUTION

PRODUCT DAMAGE MAY OCCUR.
Never attempt to disassemble or alter the product in any way not instructed by this manual.

Safety Information

Please read and understand this entire manual before attempting to assemble, operate or install the product.

- Read all instructions before using this appliance.
- This appliance is hot when in use. To avoid burns, do not let bare skin touch hot surfaces. If provided, use handles when moving this appliance. Keep combustible materials, such as furniture, pillows, bedding, papers, clothes and curtains at least 3 ft. (914 mm) from the front of this appliance and keep them away from the sides and rear.

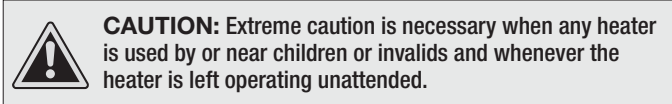

- If possible, always unplug this appliance when not in use.
- Do not operate any heater with a damaged cord or plug or after the appliance malfunctions, has been dropped or damaged in any manner.
- Any repairs to this appliance should be carried out by a qualified service person.
- Under no circumstances should this appliance be modified. Parts having to be removed for servicing must be replaced prior to operating this appliance again.
- Do not use outdoors.
- This heater is not intended for use in bathrooms, laundry areas and similar indoor locations. Never place this appliance where it may fall into a bathtub or other water container.
- Do not run the cord under carpeting. Do not cover the cord with throw rugs, runners or the like. Arrange the cord away from traffic areas and where it will not be tripped over.
- To disconnect this appliance, turn the controls to the off position, then remove the plug from the outlet.
- Connect to properly grounded outlets only.
- This appliance, when installed, must be electrically grounded in accordance with local codes, with the current CSA C22.1 Canadian Electrical codes or for USA installations, follow local codes and the National Electric Code, ANSI/NFPA No. 70.
- Do not insert or allow foreign objects to enter any ventilation or exhaust opening, as this may cause an electric shock, fire, or damage to the appliance.
- To prevent possible fire, do not block air intakes or exhaust in any manner. Do not use on soft surfaces, like a bed, where openings may become blocked.
- This appliance has hot and arcing or sparking parts inside. Do not use it in areas where gasoline, paint, or flammable liquids are used or stored. This appliance should not be used as a drying rack for clothing, nor should Christmas stockings or decorations be hung on or near it.
- Use this appliance only as described in this manual. Any other use not recommended by the manufacturer may cause fire, electric shock, or injury to persons.
- Always plug heaters directly into a wall outlet/receptacle. Never use with an extension cord or relocatable power tap (outlet/power strip) because of the risk of overheating the cord and the risk of fire. Extension cords are for temporary use only. If an extension cord must be used, it must be UL/CSA certified, rated at 15A (1,875W), 125V maximum with 14 AWG minimum and constructed of two current carrying conductors with ground. A heavy duty extension cord with the shortest length possible for the connection is recommended and must not be longer than 50 ft. (15.2 m). Do not coil or cover the extension cord.
- "SAVE THESE INSTRUCTIONS FOR FUTURE USE"

Safety Information (continued)

DANGER



ELECTRICAL CONNECTION

A 15-Amp, 120-Volt, 60 Hz circuit with a properly grounded outlet is required. Preferably, the item will be on a dedicated circuit as other appliances on the same circuit may cause the circuit breaker to trip or the fuse to blow when the heater is in operation. The unit comes standard with a 6 ft. (1.8 m) long three wire cord, exiting the right side of the item. Always plug the unit into a wall outlet/receptacle. An extension cord or re-locatable power tap, (outlet/power strip), should never be used.

 **WARNING:** Electrical outlet wiring must comply with local building codes and other applicable regulations to reduce the risk of fire, electrical shock and injury to persons.

 **WARNING:** Do not use this fireplace if any part of it has been under water. Immediately call a qualified service technician to inspect the fireplace and replace any part of the electrical system which has been under water.

GROUNDING INSTRUCTIONS

This heater is for use on 120 volts. The cord has a plug as shown at (A) in Figure 1. An adapter as shown at (C) is available for connecting three-blade grounding-type plugs to two-slot receptacles. The green grounding lug extending from the adapter must be connected to a permanent ground such as a properly grounded outlet box. The adapter should not be used if a three-slot grounded receptacle is available.

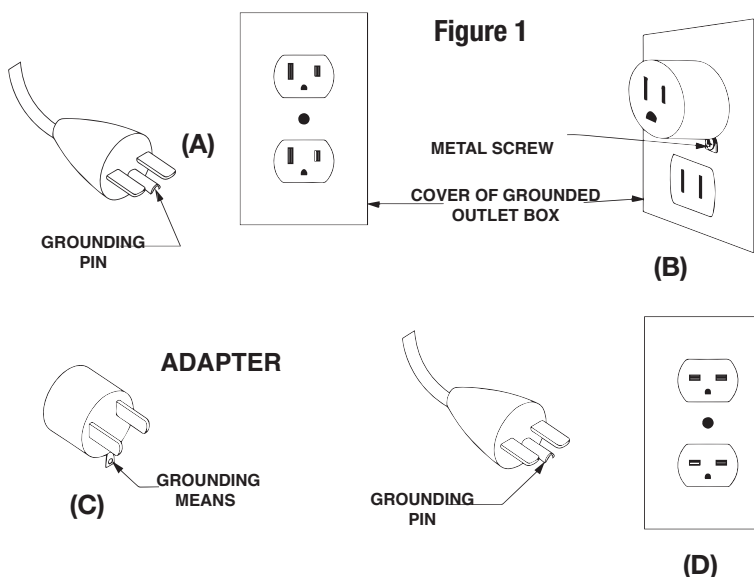

Warranty

1-YEAR WARRANTY

WHAT IS COVERED

The manufacturer warrants that your new electric fireplace is free from manufacturing and material defects for a period of one year from date of purchase, subject to the following conditions and limitations.

Variations in actual wood color and finishes which may result from natural characteristics of the wood, such as grain patterns, mineral streaks and the like, are not considered defects. As wood continues to move and age you may notice these slight differences in color, even on different parts of any individual unit. Sound knots and slight surface cracks are the true personality of a quality piece of wood furniture.

This electric fireplace must be installed and operated at all times in accordance with the instructions furnished with the product. Any alteration, willful abuse, accident, or misuse of the product shall nullify this warranty. This warranty is non-transferrable, and is made to the original owner, provided that the purchase was made through an authorized supplier of the manufacturer. This warranty is limited to the repair or replacement of part(s) found to be defective in material or workmanship, provided that such part(s) have been subjected to normal conditions of use and service, after said defect is confirmed by the manufacturer's inspection. The manufacturer may, at its discretion, fully discharge all obligations with respect to this warranty by refunding the wholesale price of the defective part(s).

WHAT IS NOT COVERED

Any installation, labor, construction, transportation, or other related costs/expenses arising from defective part(s), repair, replacement, or otherwise of same, will not be covered by this warranty, nor shall the manufacturer assume responsibility for same. Further, the manufacturer will not be responsible for any incidental, indirect, or consequential damages, except as provided by law.

All other warranties - expressed or implied - with respect to the product, its components and accessories, or any obligations/liabilities on the part of the manufacturer are hereby expressly excluded. The manufacturer neither assumes, nor authorizes any third party to assume, on its behalf, any other liabilities with respect to the sale of this product. The warranties as outlined within this document do not apply to non-manufacturer accessories used in conjunction with the installation of this product.

This warranty does not cover the lightbulb(s) included with the fireplace.

This warranty is void if: the fireplace has been operated in atmospheres contaminated by chlorine, fluorine, or other damaging chemicals; the fireplace is subjected to prolonged periods of dampness or condensation; the fireplace is altered, willfully abused, damaged by accident, or misused in any way.

If warranty service is needed, contact the Customer Service Team at 1-800-527-0313 from 8 a.m. - 6 p.m., EST, Monday-Friday or visit www.hamptonbay.com.

Make sure you have your warranty, your sales receipt, and the model/serial number of your product.

DO NOT ATTEMPT TO DO ANY SERVICE WORK YOURSELF.

Pre-Installation

PLANNING INSTALLATION

To avoid scratching the finish, assemble the product on a soft, non-abrasive surface, such as carpet or cardboard.
Assembly of this product may require more than one person.

TOOLS REQUIRED



Phillips
screwdriver

HARDWARE INCLUDED

 **NOTE:** Hardware not shown to actual size.



Part	Description	Quantity
AA	Wrench	1
BB	Mounting Bracket	2
CC	Screw (1-3/8 in.)	2
DD	Nylon Strap	1
EE	Wall Anchor	2
FF	Screw (5/8 in.)	2

Pre-Installation (continued)

PACKAGE CONTENTS

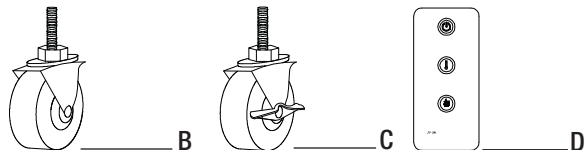
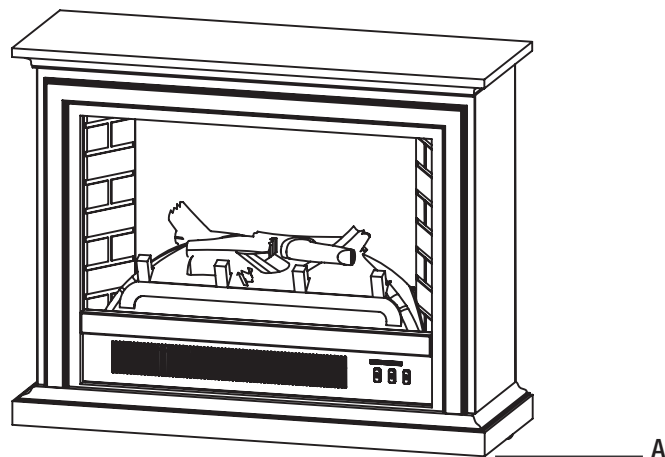

Part	Description	Quantity
A	Mantel (with fireplace insert)	1
B	Front Caster	2
C	Rear Brake Caster	2
D	Remote Control	1

Pre-Installation (continued)

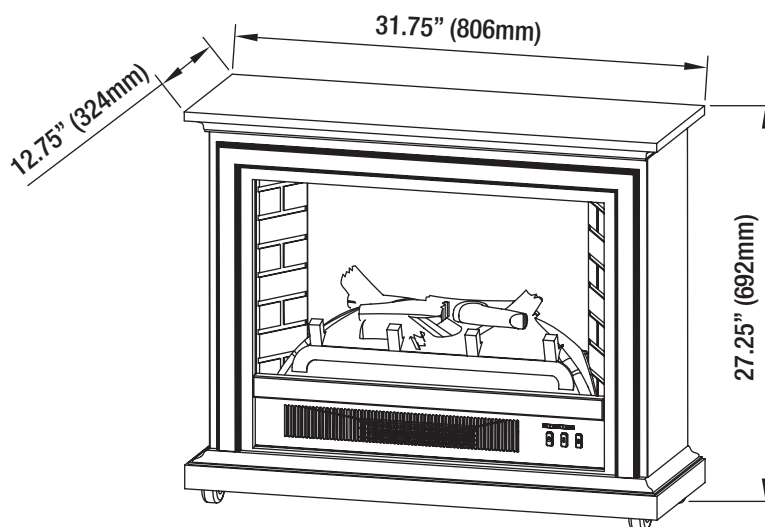

Clearance to Combustibles	
Sides	2 27/64 in. (61.5 mm)
Floor	0 in. (0 mm)
Top	2 in. (51 mm)
Front	36 in. (914 mm)
Rear	0 in. (0 mm)

Specifications	
Voltage	120 V AC
Frequency	60Hz
Heater Rating	1350W
Max. Amps	12.5A
Width	31.75" (806mm)
Depth	12.75" (324mm)
Height	27.25" (692mm)

Installation

1 Attaching the casters to the mantel



NOTE: To avoid scratching the finish, assemble the product on a soft, non-abrasive surface, such as carpet or cardboard.

- Lay the mantel (A) on its back.
- Screw a front caster (B) into the pre-drilled hole in the front-right corner of the mantel (A) base.
- Screw a rear brake caster (C) into the pre-drilled hole in the right-rear corner of the mantel (A) base.
- Repeat this process for the left side of the mantel (A) base.
- Tighten all of the casters with the wrench (AA) provided.

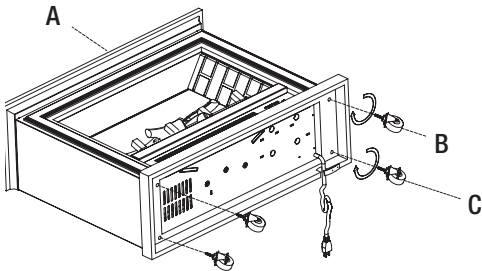

2 Attaching the mounting bracket to the mantel

- Attach a mounting bracket (BB) to the top edge of the back of the mantel (A) by inserting two screws (FF) through the mounting bracket (BB) and into the pre-drilled holes in the mantel (A). Tighten with a screwdriver.

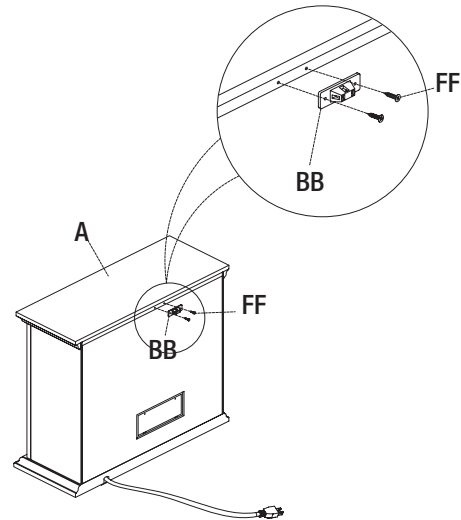

3 Attaching the mounting bracket to the wall

- Attach a mounting bracket (BB) to the wall in the location you have selected to put the mantel (A) by positioning the mounting bracket (BB) at approximately the same height as the mounting bracket (BB) previously attached to the mantel (A).
- Insert screws (CC) through the mounting bracket (BB) and into a wall stud. If there is no stud present, insert wall anchors (EE) before inserting the screws (CC). Tighten with a screwdriver.

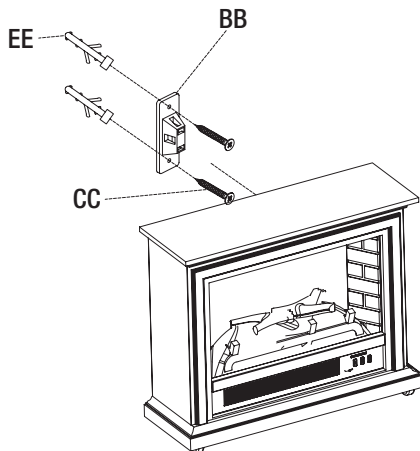

4 Attaching the nylon strap



DANGER: This product is only a deterrent. It is not a substitute for proper adult supervision.

- Set the mantel (A) 2-3 inches from the wall with both mounting brackets (BB) aligned.
- Slip the nylon strap (DD) through the openings in each of the mounting brackets (BB) and secure the nylon strap (DD). This will help prevent the mantel from tipping.

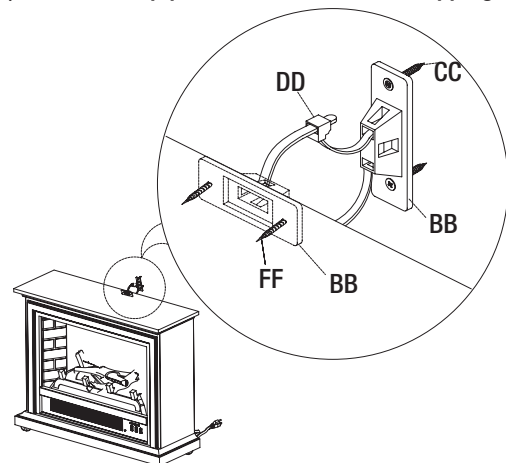

Operation



NOTE: When the heat function is used for the first time, a slight odor may be present. This is normal and should not occur again unless the heater is not used for an extended period of time.

1 Using the Control Panel

- Check that the heater outlet grill is not covered or obstructed in anyway, and make sure the power to the unit is switched on.
- Press the appropriate button to operate your fireplace:
 1. **Main Power Button:** This button supplies power to all of the fireplace functions. It must be turned on for the fireplace to work.
 2. **Heater Control Button:** This button controls the heater ON/OFF and 5 temperature modes from Low to High. When the heater is first turned on, it will come on at the lowest room temperature setting. The log set will remember the last heat setting and in later use the heater will start at that setting, unless power to the unit has been interrupted. Each time the temperature button is pressed, the temperature set point increases, allowing you to adjust the ambient temperature.
 3. **Heater Locking Function:** When fireplace is ON, press the main power button (1) for 10 seconds. The heater will be locked, and the heater control button (2) on the control panel as well as on the remote control will be disabled. Before the heater is locked, the flame will flash 6 times. To unlock the the heater, press the main power button (1) for 10 seconds. Before the heater is unlocked, the flame will flash 6 times.
 4. **Flame Control Button:** This button controls the brightness of the flame effect with settings at High, Medium, and Low. When the log set is first turned on, the flame will come on at the highest setting. The log set will remember the last flame setting used and in later use the flame brightness will start at that setting, unless power to the unit has been interrupted. Each time the flame button is pressed, the flame brightness decreases. The only way to turn off the flame effect completely is to turn off the main power button (1).

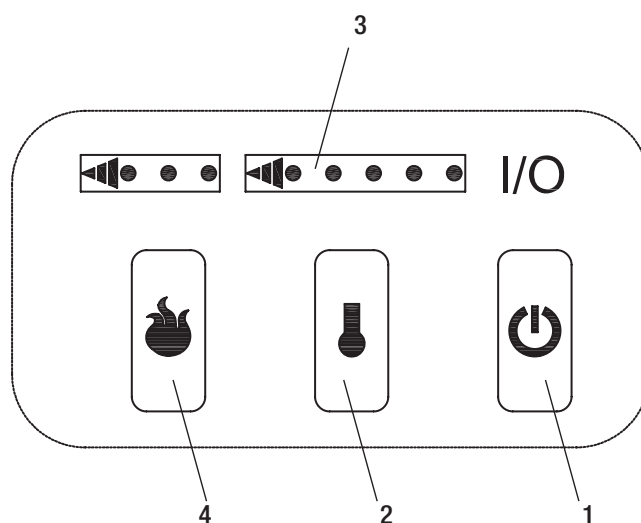

Maintenance

GLASS INFORMATION

- Under no circumstances should this product be operated with broken glass.
- Do not strike or slam the glass.
- Do not use abrasive cleaners to clean the glass.
- This product uses tempered glass. Replacement of the glass supplied by the manufacturer should be done by a qualified service person.

LIGHT BULB INSPECTION AND REPLACEMENT



WARNING: Light bulbs become very hot during use. Allow at least 10 minutes for the bulbs to cool before touching.



WARNING: Do not exceed 40 watts per bulb. Use of higher rated bulbs may result in a fire, causing property damage or personal injury.



CAUTION: Do not operate this heater without the access panel in place. Do not remove the back cover of this heater. There are no serviceable parts inside.

The flame effect is created by two 40-Watt light bulbs with an E-12 (small) socket base. Use only this type of light bulb. If the flame effect does not work, the bulbs may have come loose or been damaged during shipping.

To inspect or replace the bulbs:

- Unplug the power cord from the outlet.
- Locate the access panel on the back of the stove.
- Remove the screws and the panel.
- Check the bulbs to be sure they are finger tight and in working order.
- Replace any damaged or faulty bulbs. Reattach the access panel.

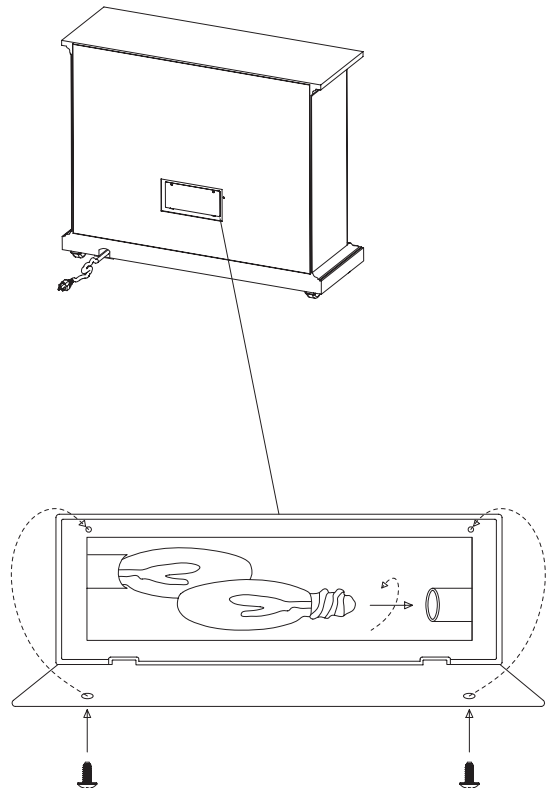

Troubleshooting

If you have any questions regarding the product, please call Hampton Bay Customer Service, 1-877-527-0313, 8 a.m. – 6 p.m. EST, Monday – Friday.

Problem	Possible Cause	Solution
The fireplace does not operate.	<ul style="list-style-type: none"> <input type="checkbox"/> The fireplace is not plugged in. <input type="checkbox"/> A circuit breaker is tripped or a fuse blown. <input type="checkbox"/> The ON/OFF switch is defective. <input type="checkbox"/> There is loose wiring. 	<ul style="list-style-type: none"> <input type="checkbox"/> Make sure the fireplace is plugged in to a standard 120V outlet. <input type="checkbox"/> Check additional appliances on the circuit; ideally the fireplace should be on a dedicated 15-amp circuit. <input type="checkbox"/> Call customer service. <input type="checkbox"/> Call customer service.
The power light is ON but the flame effect is not visible.	<ul style="list-style-type: none"> <input type="checkbox"/> The fireplace is not operating correctly. <input type="checkbox"/> There are loose light bulb(s). <input type="checkbox"/> There are burnt out light bulb(s). 	<ul style="list-style-type: none"> <input type="checkbox"/> Refer to the operating instructions. <input type="checkbox"/> Tighten the light bulb(s). <input type="checkbox"/> Replace the light bulb(s).
The heater is not operating.	<ul style="list-style-type: none"> <input type="checkbox"/> The fireplace is not operating correctly. <input type="checkbox"/> The heater switch is defective. <input type="checkbox"/> The heater assembly is defective. <input type="checkbox"/> There is loose wiring. <input type="checkbox"/> The vents are dirty or clogged. 	<ul style="list-style-type: none"> <input type="checkbox"/> Refer to the operating instructions. <input type="checkbox"/> Call customer service. <input type="checkbox"/> Call customer service. <input type="checkbox"/> Call customer service. <input type="checkbox"/> Unplug the unit. Clear the vent area of dust and debris. Wait ten minutes, plug the unit in again and turn on the heater.
There is excessive noise when the heater is operating.	<ul style="list-style-type: none"> <input type="checkbox"/> The fan is defective. <input type="checkbox"/> The heater assembly is defective. 	<ul style="list-style-type: none"> <input type="checkbox"/> Call customer service. <input type="checkbox"/> Call customer service.

Service Parts

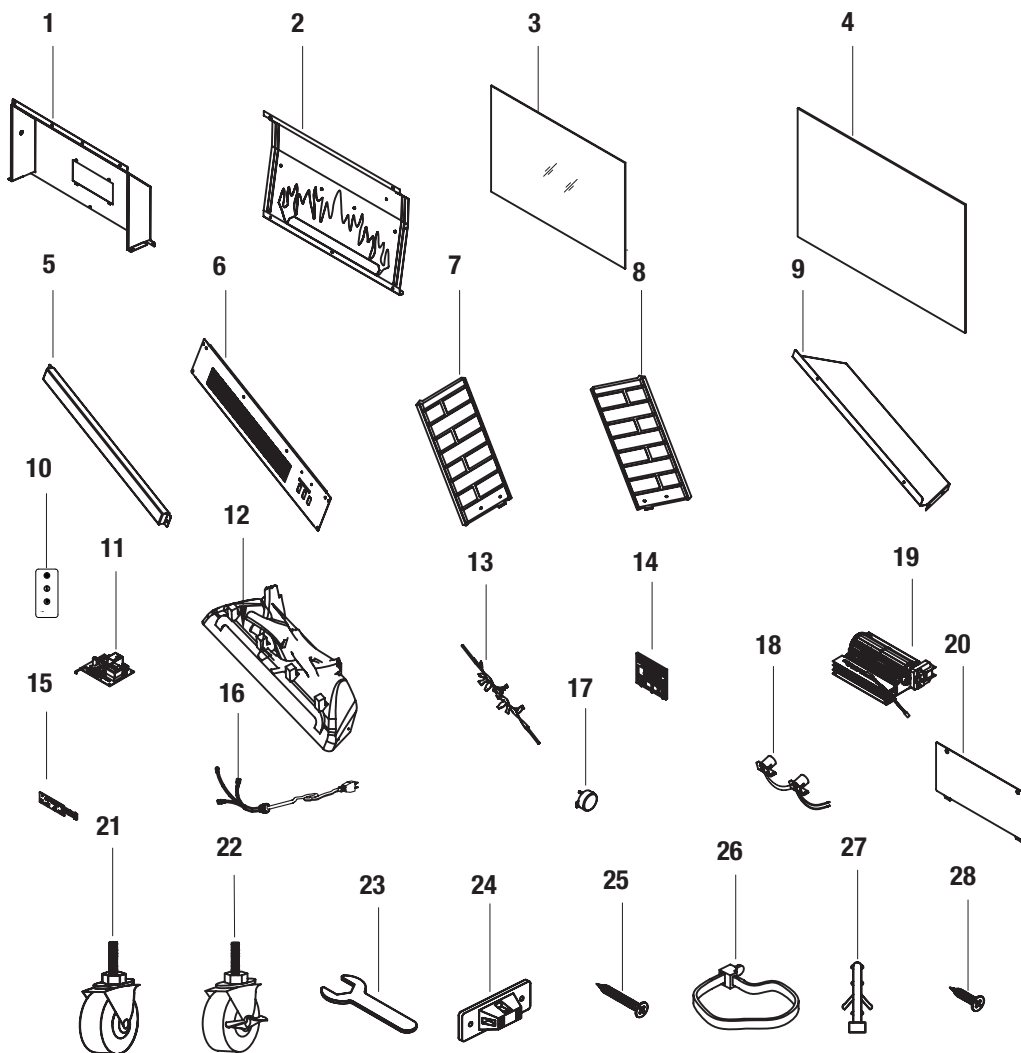

Part	Description	Part #
1	Back Panel	EF237916501AC
2	Flame Panel	EF237916502AC
3	Glass	EF237916503AC
4	Screen	EF237916504AC
5	Front Decorative Panel	EF237916505AC
6	Front Panel	EF237916506AC
7	Left Brick Side Panel	EF237916507AC
8	Right Brick Side Panel	EF237916508AC
9	Top Panel	EF237916509AC
10	Remote Control	EF33510AS
11	Main Board (PCB)	EF237916510AC
12	Logset	EF237916511AC
13	Flame Reflector	EF237916512AC
14	Control Panel	EF237916513AC

Part	Description	Part #
15	Control Panel Circuit Board	EF237916514AC
16	Power Cord & Connector	EF24900015AC
17	Synchronous Motor	EFES323020ST
18	Lamp Socket & Bracket	EFES323021ST
19	Fan Heater	EF23022501X
20	Access Panel	EFES323008ST
21	Front Caster	20-09-155
22	Rear Brake Caster	20-09-162
23	Wrench	20-09-156
24	Mounting Bracket	20-09-157
25	1-3/8 in. Screw	20-09-158
26	Nylon Strap	20-09-159
27	Wall Anchor	20-09-160
28	5/8 in. Screw	20-09-161



Questions, problems, missing parts? Before returning to the store,
call Hampton Bay Customer Service
8 a.m.-6 p.m., EST, Monday-Friday

1-877-527-0313

HAMPTONBAY.COM

Retain this manual for future use.

Manufactured by: GHP Group, Inc. • 6440 W. Howard St. • Niles, IL 60714-3302