



Utility Vehicle Operators Manual



INDEX

Section 1	Introduction Serial Number Plate Location	pages 3-4
Section 2	Safety Pre-Delivery Steps Dealer Inspection Checklist	pages 5-10
Section 3	Assembly Instructions Seat Back, Brush guard, Bumper Steering wheel Cargo Bed Seat Base	pages 11-13
Section 4	Operating Instructions 390cc 4X4 653cc 4X4 48 Volt Electric	page 14 – 29
Section 5	Maintenance Fuel Valve Lever Air Cleaner Engine Oil / Transaxle Oil Drive Belt	pages 30-33
Section 6	Troubleshooting	pages 34-40
Section 7	Parts Diagrams Wiring Diagram 2WD Dana Transaxle 265cc 2 wheel drive 340cc 2 wheel drive 4WD Dana / Hilliard Transaxle 390cc 4-wheel drive 653cc 4-wheel drive 48 Volt 2-Wheel Drive	pages 41-112
	Warranty Policy	page 113
	Contact Information	page 114
	Warranty Registration Certificate	page 115

Section 1 Introduction

American SportWorks welcomes you to its growing family of new product owners. This Utility Vehicle “UTV” is a light utility vehicle that has been designed with care and built by skilled workers using quality materials. Proper set-up, maintenance and safe operating practices will help you get years of satisfactory use from this vehicle.

Safety First

American SportWorks is fully aware of the need for safe operating procedures around all of our equipment. We hope you will make a sincere effort to put safety above all other priorities. The Utility Vehicle was designed and built for work, recreation, and enjoyment; however, improper and irresponsible operation could result in serious injury or death. Since this is an off-road vehicle, operators will seldom see the road safety and warning signs they are accustomed to seeing on highways and public streets. This places additional responsibility on the driver to operate this vehicle well within the safe operational limits and capabilities of the unit.

This manual has been prepared to instruct you in the safe and responsible operation of your Utility Vehicle. Read and abide by all safety alert information about this vehicle. If you do not understand any part of this manual, contact your local dealer for additional information and clarification. As the operator of this piece of equipment, you are in complete control. Only you can prevent an accident from happening.

Using This Manual

* Prior to any vehicle operation it is absolutely essential that you read and comprehend each section in this manual to develop an understanding of your vehicle and for your safety. After reviewing this manual, store it in a dry and easily accessible place for future reference.

* The Operator’s Section is designed to help familiarize you with safety, assembly, operation, adjustments, troubleshooting, and maintenance. Read this manual and follow the recommendations to help ensure safe and efficient operation.

* The information contained within this manual was current at the time of printing. Some parts may change slightly to assure you of the best performance.

* To order a new Operator’s or Parts Manual contact your authorized dealer.

American SportWorks LLC
Toll Free PH: 1-866-646-5278
Fax: 1-866-329-5278
www.amsportworks.com

Terminology

Right-hand and left-hand as used in this manual are determined by facing the direction the vehicle will travel while in use unless otherwise stated.

Getting Acquainted with your Utility Vehicle

This off-road utility vehicle is a very unique vehicle designed exclusively for off-road use. It is not designed, properly equipped, or licensed to be safely operated on public streets and highways. This vehicle is designed to carry two people and a limited amount of gear or cargo comfortably and safely over rough terrain that was only accessible by ATV’s in the past.

Unlike ATV’s that have handlebar steering, Utility Vehicle’s have a steering wheel with easy handling rack-and pinion steering. The steering’s tight turning radius makes this vehicle more maneuverable than most ATV’s. Its four wheeled independent suspension, large diameter hi-flotation tires and high center-frame ground clearance adds up to excellent stability and a smooth ride over rough terrain. Outstanding two wheeled rear traction drive is achieved by using premium off-road ATV type tires in tandem with the engine mounted directly in front of the rear differential.

Also unlike an ATV’s one person “straddle saddle” seat, the Utility Vehicle sports dual headrest cushioned seats with seat belts mounted in a highly styled and protective full length body. Two passengers can ride comfortably in this vehicle protected from splashing water and mud. The Brush Guard Bar mounted to the vehicle’s frame provides protection against low hanging limbs and briars.

Section 1 Introduction

The Brush Guard Bar also provides a mounting system for American SportWorks optional windshields, canopy tops and weather enclosures. It also serves as a mounting base for many other optional cargo racks, gun and bow racks.

The cargo bed is for transporting accessories such as camping equipment, tree stands, hunting gear, and fishing gear. A standard hitch mounting plate enables quick installation of a rear hitch for pulling small trailers full of supplies, tools, gear, and game.

The Utility Vehicle has some similarities to an ATV. Like an ATV the Utility Vehicle has a short wheelbase, narrow stance, and high center clearance all which provide for narrow and difficult trail access. This combination of short wheelbase and narrow stance also enables this vehicle to be loaded in the back of most full to mid-sized pickups for transport.

The Utility Vehicle's ground compaction and is very gentle on the ground and surrounding vegetation. The highly energized four wheeled independent suspension system provides an incredibly soft ride and outstanding stability over difficult terrain. The engine is EPA certified and meets California Air Resources Board (CARB) certification standards.

Owner Assistance

The safety information should be viewed by the owner and the Warranty Registration card should be filled out by the dealer at the time of purchase. The owner, upon purchasing the vehicle, should have participated in a short drivers training course with the dealer. This information is necessary to provide you with quality customer service.

The parts on your Utility Vehicle have been specially designed and should only be replaced with genuine American SportWorks parts.

If customer service or repair parts are required contact a American SportWorks dealer. They have trained personnel, genuine repair parts and equipment specially designed to repair American SportWorks products.

American SportWorks LLC
4404 Engle Ridge Drive
Fort Wayne, IN 46804
Toll Free PH: 1-800-643-7332
Fax: 1-800-399-1399
service@amsportworks.com

Always use the serial and model number when ordering parts for your Utility Vehicle. The serial-number plate is located under the cargo bed on the driver's side just above the engine, on the frame as shown in figure 1 below.



Serial Number Plate Location

Figure 1

Record your Utility Vehicle serial number here for quick reference:

Model Number: _____

Serial Number: _____

Your American SportWorks dealer wants you to be satisfied with your new vehicle. If you do not understand any part of this manual or you're not satisfied with the service received, please take the following actions.

Discuss the matter with your dealership service manager. Make sure they are aware of any problems so they can assist you.

If you are still unsatisfied, seek out the owner or general manager of the dealership.



For further assistance write to



Read These Important Rules for Safe Operation

Note: The Operator, Passenger, Parent or Guardian must read, study and understand all the items contained within this owners/operators manual before operating utility vehicle. Failure to follow these instructions could endanger the personal safety of the Operator, Passenger and any Bystanders.

Close adult supervision is required at all times!

**Pay close attention to all Caution and Warning labels
Located on the Utility Vehicle**

IMPORTANT

**When transporting any Utility Vehicle with an installed windshield or
Color matched top DO NOT reach high speeds!**

Assumption Of Risk

The owner or operator assumes all the risks incident to or arising out of the operation of
this Utility Vehicle

***Failure to follow and comply with all warnings may
cause serious injury or death***

Section 2 Safety

It is very important to read, understand, and follow all instructions and warnings located on the decals on your Utility Vehicle.

⚠ WARNING

THIS UTILITY VEHICLE CAN BE HAZARDOUS TO OPERATE IF DRIVEN CARELESSLY. SERIOUS INJURIES OR DEATH CAN RESULT IF YOU DO NOT FOLLOW THESE INSTRUCTIONS:

- * Read and fully understand owners manual and all labels before you operate this utility vehicle.
- * This vehicle was not designed or manufactured for use on public streets, roads, or highways and is not intended for such operation.
- * Children may not have the skills and experience needed to safely operate this vehicle. All operators should possess a valid drivers license.
- * Keep all covers, shields, and guards properly installed.
- * Protective head gear may be necessary when driving in rough terrain.
- * Seat Belts reduce injuries. All occupants of this vehicle should be secured in with a seat belt.
- * Never carry passengers in the cargo area of this vehicle. All passengers should be secured in the seat area.
- * Failure to apply parking brake may result in unexpected movement of this vehicle. Always apply parking brake before exiting this vehicle, especially when on uneven terrain.

⚠ WARNING

CARGO ONLY! NO PASSENGER

⚠ WARNING

Always turn engine off before refueling.
Refuel in well ventilated area.
Keep away from flame and/or sparks.

⚠ WARNING

This vehicle can NOT be transported over 55mph with Top mounted.

⚠ WARNING

DRIVING WITH THE BED RAISED IS HAZARDOUS. ALWAYS LOWER AND LATCH BED BEFORE DRIVING.

⚠ WARNING

ALWAYS SHUT OFF FUEL VALVE BEFORE TRANSPORTING THIS UTILITY VEHICLE.

⚠ WARNING

HOT SURFACE



* Allow Engine to cool for at least 2 minutes before touching.

⚠ WARNING

THIS IS AN OFF-ROAD UTILITY VEHICLE!

THIS VEHICLE WILL HANDLE AND MANEUVER DIFFERENTLY FROM ANY ORDINARY PASSENGER CAR OR TRUCK. SHARP TURNS OR ABRUPT MANEUVERS AT HIGH SPEEDS MAY CAUSE THIS VEHICLE TO ROLL OVER OR GO OUT OF CONTROL. READ AND UNDERSTAND OWNERS MANUAL BEFORE OPERATING THIS VEHICLE.

⚠ WARNING

This vehicle can NOT be transported over 55mph with Winshield mounted.

⚠ WARNING

Rear Seat Weight Limit is 300lbs

Section 2 Safety

Safe Operating Procedures

The safe operation of any machinery is a big concern to all consumers. Your Utility Vehicle has been designed with many built-in safety features. However, no one should operate this vehicle before carefully reading this Operator's Manual. Also read all instructions noted on the safety decals.

- * Be familiar with all functions of this vehicle.
- * Keep all bystanders away from this vehicle during operation.
- * Do not allow anyone to operate this vehicle who has not fully read and comprehended this manual and who has not been properly trained in the safe operation of this vehicle.
- * Do not operate a vehicle with damaged or defective parts. Repair all damages and defective parts before putting vehicle back in to service.
- * Do not allow anyone under 16 years of age to operate this vehicle.
- * Operator must always use both hands on the steering wheel.
- * No riders allowed except in factory designed and supplied seating.
- * Operate this vehicle from the driver's seat only.
- * Do not leave this vehicle unattended with engine running.
- * Do not dismount a moving vehicle as serious injury or death could occur.
- * Always operate vehicle with belt guard installed. Do not leave pulleys and belts exposed.
- * Do not touch engine, engine exhaust pipe and/or muffler while they are hot.
- * Keep hands, feet, long hair, clothing, and jewelry away from moving parts and obvious pinch points to avoid getting caught.
- * Wear snug-fitting clothing to avoid entanglement with moving parts.
- * Some conditions may warrant extra safety gear to be worn such as safety helmets and/or goggles.
- * Keep hands, arms, feet and all bodily appendages safely inside the confines of the vehicle.
- * Always be aware of and avoid tree limbs and brush that have a potential of hitting and/or poking individuals riding the vehicle. Serious body harm could result.
- * Avoid sudden stops, starts, and turns.
- * Always operate your vehicle at a safe speed that will allow you to maintain control.
- * Operator and passenger are responsible for deciding if their situation warrants using seat belts.
- * Do not exceed total payload capacity of this vehicle.
- * Do not pull a trailer or implement exceeding 1100 pound towing capacity or loss of control may result.
- * Do not attach an implement, trailer or other device to the hitch that will produce negative tongue weight.
- * Follow all towing instructions in this manual when towing the UTV behind another vehicle. Do not tow vehicle faster than 25 MPH.
- * Do not use the vehicle as an anchor device.
- * Beware, tow ropes, cables and chains can break when pulling another vehicle or object causing serious injury or death to anyone in line with the whipping action created when they break. Never jerk when pulling, always ease into a pull gently. Always stay clear of the tow line. Never be in line with the tow line.
- * Reduce speed when loaded with cargo. Heavy cargo load takes longer to stop.
- * Reduce speed and payload on hilly, rough, wet, slick or unstable ground.
- * Always make turns at a speed that will maintain control of vehicle. Never make turns at full speed. Reduce speed when turning empty and reduce speed even more when turning loaded with cargo or when pulling a cargo load. The heavier the cargo load, the slower the turn should be.
- * Make sure all gear or cargo is properly secured and tied down.

- * Do not exceed 400 lbs. in cargo bed area (**NOTE: 300lbs with rear seat kit installed**), or 900 lbs. total on this vehicle.
- * Do not mount a receiver hitch type carrier platform to the vehicle.
- * Do not load the Brush Guard Bar with heavy equipment. Rollover could result from such loading.
- * The Brush Guard Bar is not certified ROPS (Roll Over Protection System). Always avoid rollovers.
- * Do not operate this vehicle on highways, public roads, or where it may be a hazard to faster moving traffic.
- * Do not operate this vehicle while drinking or under the influence of alcohol and drugs.
- * Never attempt wheelies, jumps, or other stunts. Never drive recklessly. Always operate your vehicle at a safe speed that will allow you to maintain control.
- * Never use vehicle for racing and never modify the engine to exceed 25 MPH vehicle speed.
- * Never modify any parts on the vehicle without authorization. Unauthorized modifications will void warranty to all parts directly and indirectly affected by the modification.
- * Always make sure the vehicle pathway is clear of all objects when backing up. Know location of personnel around vehicle and especially location of small children. Take extra precautions when rear view is hindered by cargo.
- * Always park on level ground, stop engine, set parking brake and remove ignition key before leaving the vehicle. Chock tires if condition warrants.
- * Use extreme caution when cresting hills or when visibility is limited. Proceed slowly until you are sure trail conditions immediately ahead are safe.
- * Keep front wheels straight when cresting hills or going over bumps.
- * Do not stop, start suddenly or over accelerate on hills. Loss of control and rollover could result.
- * Use extreme caution when descending hills or running on loose slippery surfaces. Towing, braking, and tractive capabilities are greatly diminished.
- * Do not operate vehicle on 15 degree slopes or steeper.
- * Avoid changing direction or making sharp steering corrections on slopes or rollover may occur.
- * If this vehicle begins to tip when crossing a slope, turn the front wheels downhill to regain stability and control.
- * When crossing a slope on soft terrain, turn the front wheels slightly uphill and maintain a constant speed to maintain a straight line of travel.
- * When descending hills or slopes apply steady pressure to the foot brake to avoid potential of freewheeling or runaway.
- * Never allow vehicle to coast or free wheel in neutral or loss of control may result.
- * If your vehicle loses power and stops on a hill, immediately engage the foot brake and back slowly down the hill maintaining a straight downhill line of travel. Do not attempt to turn the vehicle sideways on the hill or a rollover could result.
- * When traveling at night always use your headlights and reduce speed according to visibility, trail, and terrain conditions.
- * Avoid water crossings when possible and never cross a body of water where depth is unknown. Loss of power will occur if the drive belt becomes submerged or wet. Unnecessary crossing of streams and waterways erodes shore line and damages water-born habitat. If you must cross, do it at a point where banks are not steep and proceed at a slow and steady speed.
- * Front bumper and brush guards are not designed as pusher bars. Do not attempt to push other vehicles or implements or damage may result.
- * When refueling use an (UL) approved non-metallic container that has no screen or filter. Set the container on the ground before fueling to eliminate static discharge and do not use Methanol fuel.
- * Do not smoke or use electrical devices including cell phones while refueling.
- * Always maintain proper tire inflation.
- * Always disconnect the negative battery terminal before making adjustments to the vehicle electrical system or welding on this vehicle.
- * Battery fumes are explosive. A spark will ignite battery fumes. Wear a face shield when charging or jumping a

battery. Follow all battery safety rules outlined in this manual.

* Avoid battery acid spills. Do not get battery acid on eyes, face, or other body parts. Flush eyes and other body parts immediately with water for at least 15 minutes if battery acid has gotten on them.

* Always check wheel lug nut torque values two hours after initial operation and two hours after each tire repair and/or replacement. Routinely check lug nut torque valves every 100 hours of operation.

* Support this vehicle securely before working beneath. Chock the wheels to prevent the vehicle from rolling.

* Do not shift transaxle unless this vehicle is fully stopped and the engine is at idle or damage may occur.

Each vehicle must undergo a Pre-Delivery Inspection by the Dealer. Listed below is an example of the checklist that is included with the Warranty Registration that is to be submitted to American SportWorks upon Retail Sale. The Pre-Delivery Certificate and Warranty Registration must be submitted to American SportWorks in order to activate the vehicle warranty.

Pre-Delivery Steps

The dealer is required to complete "Pre-Delivery" steps before customer may take possession of the vehicle. This information must be filled in and check list checked off or initialed by individuals performing the checks. Dealership's name, signatures of individuals filling in the form, seller's signature, customer's signature, and signing dates are also required.

Below is a list of the information that is required to be completed and checked off.

Vehicle Information

Model No. _____

Date _____

Serial No. _____

Engine Serial No. _____

Dealer Service and Inspection List

___ Fully charge battery. Check battery voltage to verify that it is fully charged.

___ Check fuel valve lever to make sure it is in the correct position.

___ Check tire pressure to make sure front and rear tires have **5** psi.

___ Make sure wheel lug bolts/nuts are tightened to 90 Newton meters (65ft.lbs).

___ Check engine oil level at the dipstick. Add SAE 10W30 oil if oil is below the full mark on the dipstick. *this should be done with seat (and under seat storage Tray if equipped) removed, with UTV on flat level surface

___ Check engine for correct RPM. Set to factory specification if needed.

___ Check tie rods for tightness.

___ Check Choke Control. It should move and return freely.

___ Step on foot brake to make sure the pedal is firm and does not go to the floor.

___ Make sure seats and seat belts are properly fastened to the frame.

___ Make sure all safety decals are in place.

___ Check headlights to make sure they are working and are properly mounted.

___ Inspect air cleaner element. Make certain it is clean and in place.

___ Inspect the fuel tank to make sure it is properly installed and that there are no leaks.

___ Check fuel level to make sure there is at least 1/8 of a tank of gas prior to performing initial starting operations.

___ Inspect fuel lines to make sure they are properly installed and that there are no leaks.

___ Check steering by executing a full lock to lock turn in each direction.

___ Check parking brake to make sure it will engage, hold and release.

___ Check throttle control to make sure it moves and returns freely.

___ Check differential oil level at the differential oil plug. Add 30 weight oil if oil is low.

___ Check overall appearance for cleanliness and for body and molding damage.

Dealer Test Ride List

___ Check engine for starting, accelerating, running smooth, and idling smoothly.

___ Check steering response. There should be no free play.

___ Check forward, neutral, and reverse shifting response. Also check neutral start response.

___ Check parking brake to make sure it engages, holds, and disengages.

___ Make sure throttle is responsive and returns freely.

___ Make sure the suspension ride is satisfactorily and stable.

___ Make sure there are no fuel or petroleum leaks.

___ Make sure the foot brake has a firm engagement and that stopping is straight.

___ Make sure there are no abnormal rattles or vibrations.

Dealer Delivery to Customer List

___ Warranty registration form is complete.

___ Owner's Manual has been delivered to and reviewed by the customer.

___ Engine Manual has been delivered to and reviewed by the customer.

___ Warranty Policy limits and requirements have been explained to the customer.

___ Location and functions of vehicle controls have been explained.

___ Fuel transportation and storage procedures have been explained.

___ **Transportation of utility vehicle is limited to 55mph, when equipped with top and windshield**

___ Fluid fill and lubrication points have been located and explained to the customer.

___ Information on the safety decals have been reviewed with the customer.

Customer Acceptance List

Customer initials required where accepted as successfully completed.

___ Customer has reviewed and understood warranty policy (ies).

___ Customer has inspected the vehicle and it meets customer satisfaction.

___ Customer understands the importance of following the owner's manual instructions.

*** IMPORTANT NOTICE ***
WHEN TRANSPORTING ANY
UTILITY VEHICLE WITH A WINDSHIELD OR
COLOR MATCHED TOP INSTALLED
DO NOT EXCEED 55MPH

American SportWorks LLC
Toll Free PH: 1-866-646-5278
Fax: 1-866-329-5278
www.amsportworks.com

Section 3 Assembly Instructions

Utility Vehicle Assembly Instructions



Your new Utility Vehicle Utility vehicle should include the following items to be assembled:

<u>Qty</u>	<u>Item</u>	<u>Qty</u>	<u>Item</u>
1	#8 black screw (steering cap)	2	5/8" x 4" Hex bolt
3	1/4" x 1 3/4" Hex head bolts	2	5/8" nylock nuts
7	1/4" nylock nuts	1	set of keys
4	1/4" x 3/4" carriage bolts	1	Steering wheel (with cap)
4	1/4" flat washers	1	Bumper
8	5/16" x 2" socket head bolts	2	Rear fenders
12	5/16" curved washers	2	Rear frame stubs
10	5/16" nylock nuts	1	Seat back
4	5/16" x 2" hex head bolts	1	Cage
2	5/16" center lock nuts	1	Cargo Bed with tailgate

Section 3 Assembly Instructions

Pre-Assembly Instructions

- 1) **Read Owner's Manual.**
- 2) Unpack all vehicle and assembly parts. Make sure you have everything listed on the previous page.
- 3) If you have any questions or problems with your American SportWorks LLC product please call us, **toll free 1-866-646-5278.**



Seat / Brushguard Assembly

- 1) Place seat back frame on vehicle frame tubes. Insert a 5/16" x 2" socket head bolt through both bottom joints. The head of the bolt should be on the outside of the vehicle. Put a curved washer on the threaded end of the bolt. Place a 5/16" nylock nut on the bolts but **do not tighten.**
- 2) Place the cage on front vehicle frame tubes and seat back. Insert a 5/16" x 2" socket head bolt through all four joints. The head of the bolt should be on the outside of the vehicle. Put a curved washer on the threaded end of the bolt. Place a 5/16" nylock nut on the bolts. Tighten all 6 nuts (including step 3).



Bumper Installation

- 1) Align the holes in the front bumper with the mounting holes in the front frame tubes. Insert the four 5/16" x 2" bolts through the bumper bracket and then into the frame tubes. Put a curved washer on the threaded end of the bolt. Place a 5/16" nylock nut on the bolts and tighten.

Steering Wheel Installation

- 1) Remove the plastic steering column cover by removing the 3 screws on the bottom with a 5/16" socket. If equipped with top and bottom steering column covers
- 2) Turn vehicle steering so that it is pointed straight forward. Line up holes in steering wheel with mounting holes so that the center spoke is pointing down. Install 1/4" x 1 3/4" hex head bolts from the back. Tighten with 1/4" nylock nuts.
- 3) Install steering cap with #8 black screw.
- 4) Re-install steering column cover.

Cargo Bed Installation

- 1) Locate rear frame stubs at the rear of frame. The bed pivot tube on the stub should be at the top. Insert 5/16" x 2" socket head bolt. Loosely install 5/16" center lock nut (do not tighten until after cargo bed is installed)



- 2) Place the cargo bed on the vehicle and insert a 5/8" x 4" hex head bolt through each pivot bracket and frame stub tube.
- 3) Tighten both 5/16" frame stub bolts and nuts.
- 4) Install the 5/8" nylock nuts on the pivot bolts. Tighten the pivots and then loosen 1/4 turn.
- 5) Loosen the bed latch pin bolt on the frame just enough for it to slide in the adjustment slot. (shown in upper right photo)
- 6) Close the bed and position the latch pin bolt so that it is at the bottom of the latch slot to prevent rattles. Tighten the latch pin.

- 7) Fenders installation (if Equipped, no fenders on TW265) Tilt the cargo bed up. Line up the holes in the rear fenders with the square holes in the bed. The raised rectangular surface on the fender should be completely hidden under the bed. If not, turn the fender around. Insert a 1/4" x 3/4" carriage bolt through the bed and into the fender. Fasten with a 1/4" flat washer and a 1/4" nylock.



Seat Base Installation

- 1) Place tabs attached to seat base under front seat frame bar (if equipped into slots in plastic tray), fold seat base into position. (if equipped The rear tabs should fall into the slots in the rear of the plastic tray)

Section 4 Operating Instructions

General Operation

Start your Utility Vehicle by following the starting procedures as noted below.

1. Depress brake pedal with your foot and hold. Pull firmly up on the park brake lever with your hand until the lever is tight.
2. Place gearshift in neutral
3. Apply choke fully when engine is cold.
4. Turn ignition key fully clockwise and hold to stop engine.
5. Release ignition key to run position and choke to normal operating position immediately after engine starts.
6. Turn ignition key counterclockwise to stop engine.

Driving is as easy as driving a car with an automatic transmission. A simple forward and reverse shifter provides direction control.

Just turn the key and the 12 volt electric starter provides safe and easy starting. There is a manual choke control below the seat for quick cold weather starting. A back-up pull-rope starter mechanism is provided on the engine just in case you accidentally leave the key on and run the battery down. The infinitely variable torque converter drive system means there is no clutching. You just shift into either forward or reverse when the vehicle is stopped and press the throttle pedal to go. Never shift while the vehicle is moving.

Braking is accomplished by simply depressing the brake pedal that is located on the floorboard left of the accelerator. A lever action parking brake control is mounted on the center console located between the operator and passenger seats. Depress the button on the park brake control lever to release the park brake.

Pre-Start Check List

- Check tire pressure as indicated.
- Make sure wheel lug bolts/nuts are tightened to 65ft. lbs.
- All nuts, bolts, screws, and fasteners should be checked.
- Turn on headlights to make sure battery has a charge and electrical lighting circuit is working.
- Check tail lights and brake lights. (if applicable)
- Check park brake to make sure it will engage, hold and release.
- Check steering by executing a full lock to lock turn in each direction.
- Check engine oil level at the dipstick. Add oil as indicated.
- Check differential oil level at the differential oil plug. Add gear lube as indicated.
- Check fuel valve lever position. Valve lever should be off except when running the engine.
- Check fuel level to make sure there is at least 1/8 of a tank of gas prior to performing initial starting operations.

4x4 Utility Vehicles

This supplement covers the additional features, operation and maintenance of the 4x4 Utility Vehicles

Features

- 653cc Subaru engine
- 390cc Honda engine
- Electric 4x4 selection
- Auto-Locking front differential
- Manual locking rear differential
- 4 wheel hydraulic brakes
 - Front disk
 - Rear drum
- Long travel strut front suspension

Operation of Four Wheel Drive Features

The rear axle is equipped with a manually operated differential lock. It is engaged (locked) by moving the differential lever to the left and down. Locking the differential sends equal power to both rear wheels for better traction. It may be used in both 2WD and 4WD modes.

Note: Locking the differential on paved or hard surfaces may increase steering effort and tire wear.

To switch to four wheel drive, the front wheels are engaged simply by flipping the dashboard switch to 4WD. In 4WD mode power is automatically sent to the front wheels when the rear wheels lose traction.

Warning: Bring engine to an idle before selecting 4WD mode. Sudden engagement of 4X4 switch under power may damage drive train. Failure to do so may void warranty.

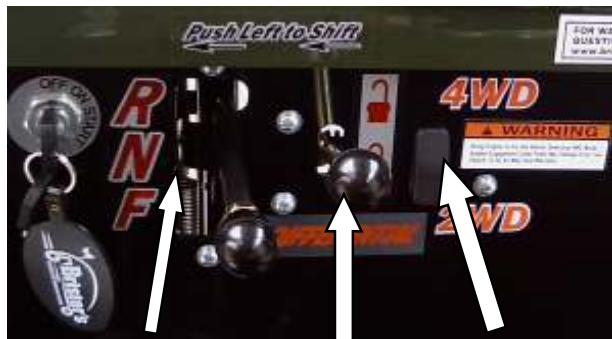

F-N-R
Shift
Lever

Differential
Lever
"Push to Left"

4WD
On/Off
Switch

Because the power transfer is automatic, you may operate the vehicle in 4WD mode continuously without affecting steering effort or tire wear.

Maintenance

Hydraulic Brakes – Hydraulic Brakes use fluid pressure to transfer the braking force to the wheels. Before driving the vehicle each day, check the fluid



level in the reservoir. The reservoir is located under the hood behind the front differential gear box. Fill to the MAX line with DOT 3 brake fluid.

If you notice that the brake pedal feels spongy or the vehicle is not stopping well, take the vehicle to a qualified service center.

Front Differential Gear Box – It is recommended that the oil be changed once every 2000 miles (about 150 to 200 hours). To change the oil, follow each step on the procedure listed below.



- 1 Remove the oil drain plug located on the bottom of the gear case using a 7/16" socket.
3. Let all the oil drain out of the unit. Catch and discard the oil properly.
4. Be sure to clean off any debris on the drain plug and reinstall using a new nylon washer

(part #20843). Torque the oil drain plug to 9 ft*lbs.

5. Remove the oil fill plug using a 5/16" hex key wrench.
6. Add 150 ml. (5 oz.) of Mobil fluid 424 American SportWorks part # **20848** (*note: do not use any other type of oil in this system or the 4WD will not operate properly!*)
7. Reassemble the oil fill plug into the gear case and torque to 10 ft*lbs.

Gear Spacing adjustment

1. Locate set screw on front gear box.
2. Turn clockwise until you feel resistance.
3. Turn back counter clockwise ¼ turn.



Rear Transaxle Gear Box – It is recommended that the oil be changed once a year or after 600 hours. See page 18 of owner's manual.

90° Transfer Gear Box – It is recommended that the oil be changed once a year or after 600 hours.

1. Remove the oil drain plug located on the bottom of the gear case using a ¼" hex key wrench.
2. Let all the oil drain out of the unit. Catch and discard the oil properly.
3. Be sure to clean off any debris on the drain plug and reinstall. Torque oil drain plug to 10 ft*lbs.
4. Remove the oil fill plug using a ¼" hex key wrench.
5. Add 200 ml. (7 oz.) of 80W90 gear oil.
6. Reassemble the oil fill plug into the gearcase and torque to 10 ft*lbs.



Strut ball joint lube – It is recommended that the lower strut ball joint be lubricated every 3 months or after driving in water, mud or dusty conditions. The grease fitting is located on the back side of the strut. (see photo)



48 Volt Utility Vehicle OWNERS MANUAL

BEFORE INITIAL USE

Read, understand and follow the safety label on the instrument panel. Be sure you understand how to operate the vehicle, its equipment and how to use it safely. Maintaining good performance depends to a large extent on the operator.



Improper use of this vehicle could result in severe injury or death.

Plan carefully before using the vehicle to go significant distances over questionable terrain. Remember that a one hour drive may take many hours to walk out should you run out of battery power or be stranded by becoming stuck on unsuitable terrain.



Do NOT let metal objects fall from the seat onto the top of your batteries. This may cause a serious power short and possibly a fire.



Hydrogen gas is generated as a natural part of the lead acid battery charging process. A 4% concentration of hydrogen gas is explosive and could cause severe injury or death. Charging must take place in an area that is adequately ventilated (minimum of 5 air exchanges per hour).

To reduce the chance of battery explosion that could result in severe injury or death, never smoke around or charge batteries in an area that has open flame or electrical equipment that could cause an electrical arc.

Hydrogen gas is generated in the charging cycle of batteries and is explosive in concentrations as low as 4%. Because hydrogen gas is lighter than air, it will collect in the ceiling of buildings necessitating proper ventilation. Five air exchanges per hour is considered the minimum requirement.

Never charge a vehicle in an area that is subject to flame or spark. Pay particular attention to natural gas or propane gas water heaters and furnaces.



Ref Sgl 1S

Always wear a safety shield or approved safety goggles when adding water or charging batteries.

Any electrolyte spills should be neutralized with a solution of 1/4 cup (60 ml) sodium bicarbonate (baking soda) dissolved in 1 1/2 gallons (6 liters) of water and flushed with water.

Overfilling batteries may result in electrolyte being expelled from the battery during the charge cycle. Expelled electrolyte may cause damage to the vehicle and storage facility.

Aerosol containers of battery terminal protectant must be used with extreme care. Insulate metal container to prevent can from contacting battery terminals which could result in an explosion.

Battery Prolonged Storage

All batteries will self discharge over time. The rate of self discharge varies depending on the ambient temperature and the age and condition of the batteries.

A fully charged battery will not freeze in winter temperatures unless the temperature falls below -75° F (-60° C).

For winter storage, the batteries must be clean, fully charged and disconnected from any source of electrical drain. Please assure that the key switch is in the off position for storage.

As with all electric vehicles, the batteries must be checked and recharged as required or at a minimum of 30 day intervals.

WASHING YOUR 48 VOLT ELECTRIC UTV

It is acceptable to wash your electric utility vehicle, though a pressure washer should not be used, and common sense should be exercised. Remember that some of the electronics in the controller and charging system are sensitive to water and corrosion. The charger should be protected during washing by placing a plastic bag or other protection over the top of the charger before washing. Allow for any water that does get on/in the charger to dry out before using.

!! Deep Water Crossings Must be Avoided !!

Charge Gauge



Before operating the 48V, make sure the batteries have a full charge!

Located on the dash, the charge gauge indicates approximately the state of charge of the batteries. Far right (as shown) indicates batteries are fully charged, far left indicates a low charge.

Battery Charging

- Your charger is equipped with a flooded / gel charge mode switch, set switch to **FLOODED** mode.
- Plug the AC cord into a **grounded** outlet. If an extension cord is used, a heavy duty cord of no more than 25 feet must be used. The extension cord must be AWG 12 or heavier.
- Turn charger on.
- A fully discharged battery set will take 9-12 hours to fully recharge.



BATTERY WATERING

Flooded batteries need water. More importantly, watering must be done at the right time and in the right amount or else the battery's performance and longevity suffers.

Water should always be added after fully charging the battery. Prior to charging, there should be enough water to cover the plates. If the battery has been discharged (partially or fully), the water level should also be above the plates. Keeping the water at the correct level after a full charge will prevent having to worry about the water level at a different state of charge.

Depending on the local climate, charging methods, application, etc. Trojan recommends that batteries be checked once a month until you get a feel for how thirsty your batteries are.

Important things to remember:

1. Do not let the plates get exposed to air. This will damage (corrode) the plates.
2. Do not fill the water level in the filling well to the cap. This most likely will cause the battery to overflow acid, consequently losing capacity and causing a corrosive mess.
3. Do not use water with a high mineral content. Use distilled or deionized water only.

CAUTION: The electrolyte is a solution of acid and water so skin contact should be avoided.

Step by step watering procedure:

1. Open the vent caps and look inside the fill wells.
2. Check electrolyte level; the minimum level is at the top of the plates.
3. If necessary add just enough water to cover the plates at this time.
4. Put batteries on a complete charge before adding any additional water (refer to the Charging section).
5. Once charging is completed, open the vent caps and look inside the fill wells.
6. Add water until the electrolyte level is 1/8" below the bottom of the fill well.
7. A piece of rubber can be used safely as a dipstick to help determine this level.
8. Clean, replace, and tighten all vent caps.

Mode Switch

Your 48V UTV is equipped with a mode switch. These two modes allow for parental control of the speed of the vehicle.

The switch is located on the left side of the vehicle, under the bed. The fast mode will allow speeds up to 18 mph. The slower mode will allow speeds up to 10 mph. "Slow Mode" also has a more gentle acceleration curve. The vehicle range is considerably greater in slow mode as well.



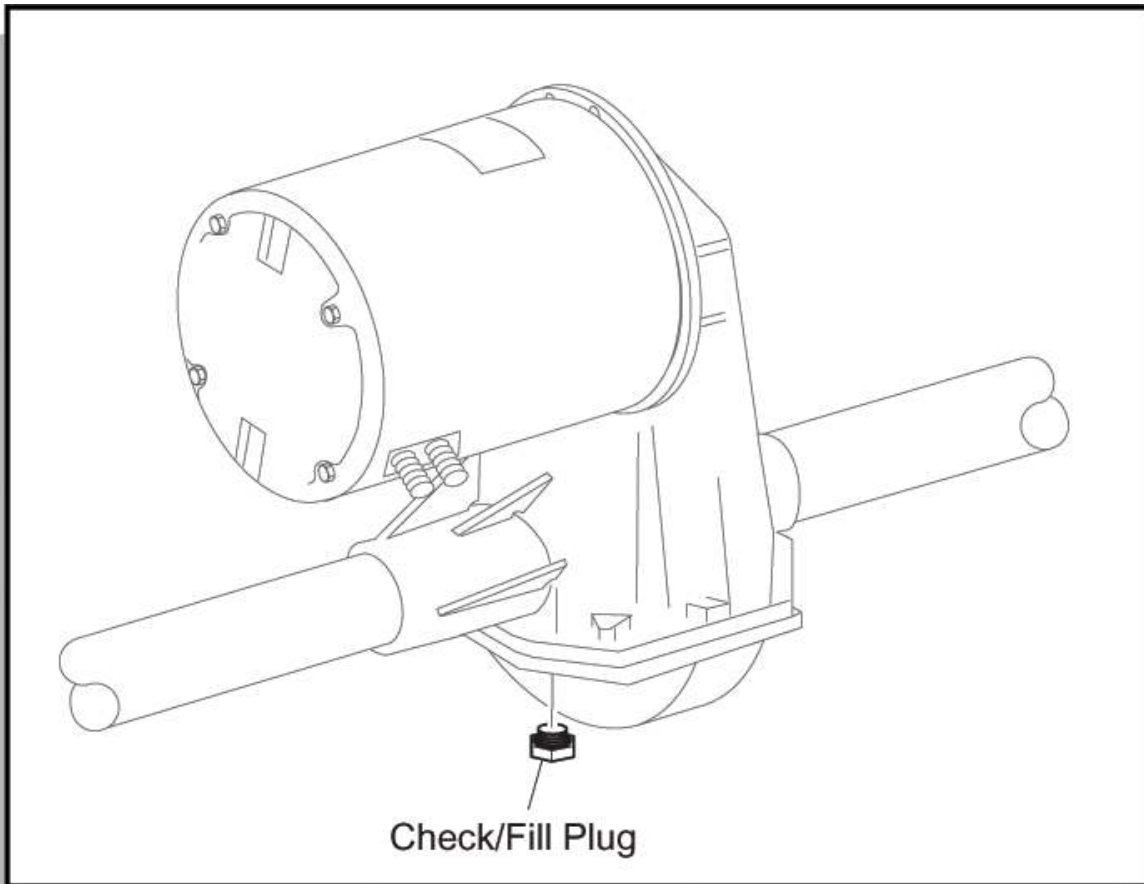

Add, Check and Drain Axle Lubricant

SAE 30W oil is used in the transaxle..

Oil should be changed after one year of normal use, and every other year after.

To change the oil, a vacuum device may be used to remove the old fluid.

To fill, fresh oil should be added up to the level of the plug.

Fuses

Your 48V Vehicle has fused protection for the main motor circuit, along with the low amperage 48 volt circuit, and the 12 volt circuit. Pictured below is the 500 amp main fuse. This fuse will blow in the event of a short across the battery posts, or a catastrophic failure in the motor or controller. Should this fuse blow, it must be replaced with a like 500 amp fuse. These fuses are available through your dealer. Main fuse is illustrated below.



In addition to the main fuse, there are three smaller fuses to protect the 12volt and 48 volt circuits. These fuses are illustrated below. Should these fuses blow and need replacement, a replacement fuse of the same rating must be used.

Under Hood

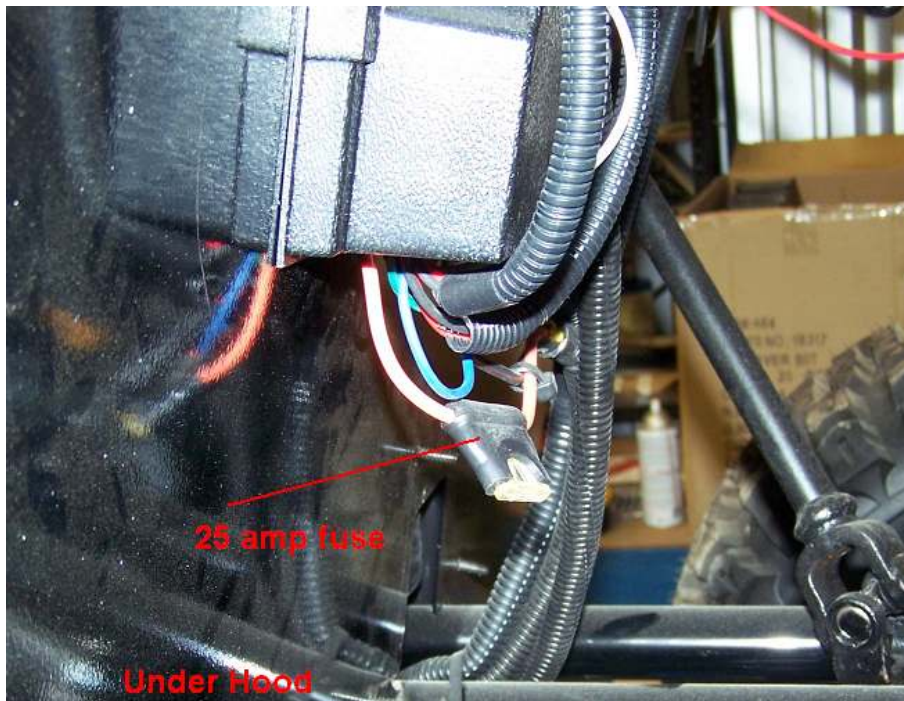

Under Bed Left Side



Forward / Reverse Switch

Located on the dash, the forward/reverse switch selects the direction of the vehicle. The operator must select the proper switch position before applying the throttle.

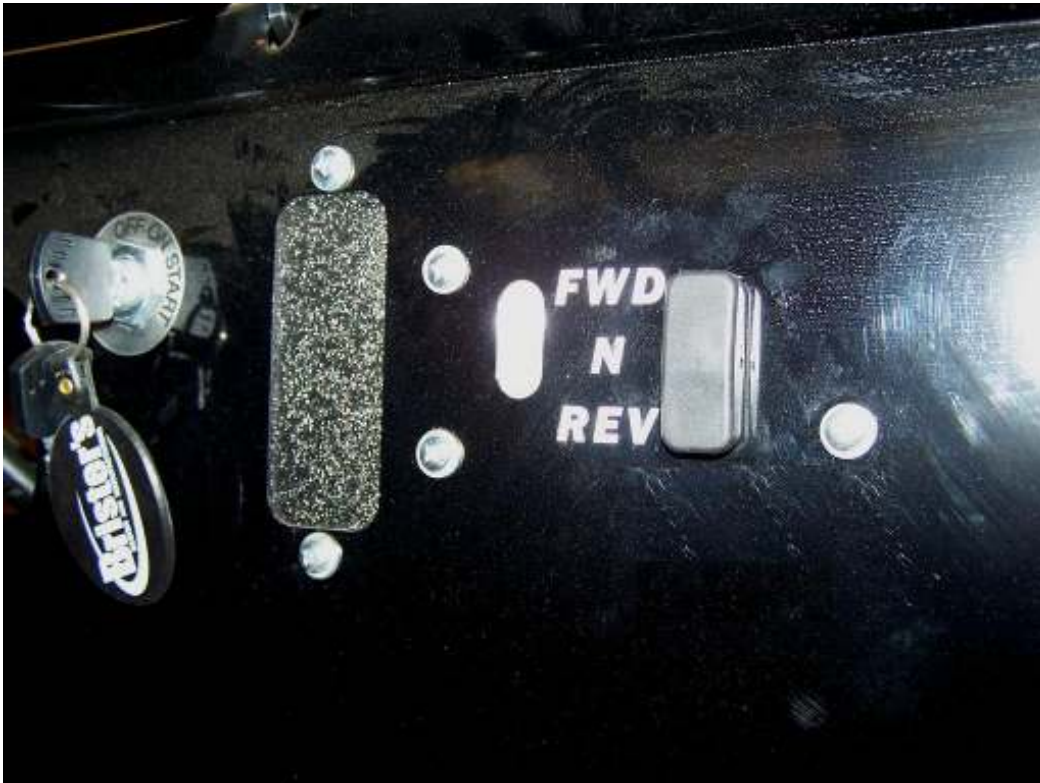

! WARNING !

Before depressing the accelerator pedal, operator must be certain of the position of the forward / reverse switch. Unexpected movement will result if the switch is inadvertently in the incorrect position.

Wiring Diagram next page.

Please note that not all circuits illustrated are included on all models. Please disregard circuits that do not apply to your application.

Warning
Accessories Must NOT be Grounded to Chassis.
Damage to Converter Will Occur
Ground to Distribution Block Ground (Neg) Terminal Only
Please See Illustration Below

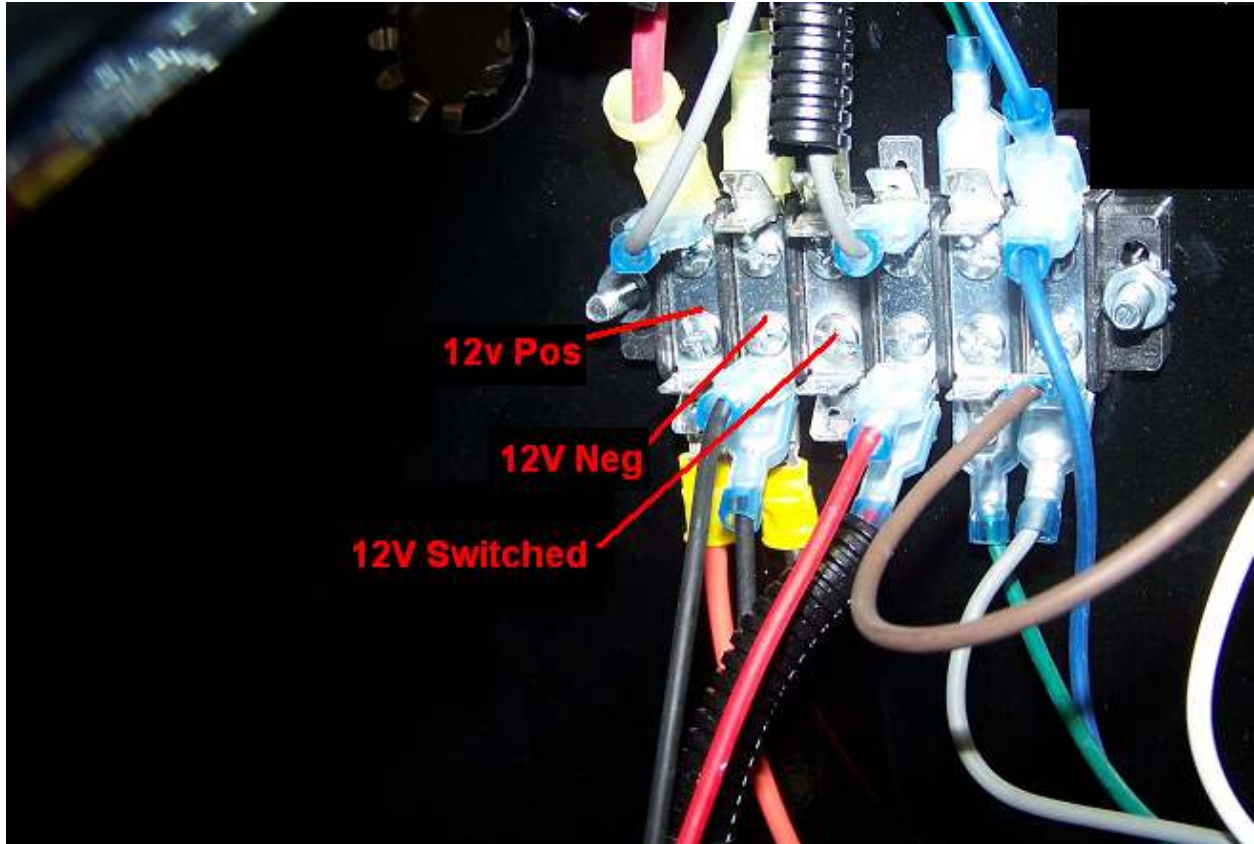

650cc Utility Vehicle OWNERS MANUAL Supplement



This vehicle is capable of reaching speeds in excess of 25mph. Use caution when turning to avoid vehicle rollover. Improper operation of this vehicle may cause serious injury or death. Maintaining safe performance depends to a large extent on the operator.

Read, understand and follow all warning decals as well as your entire owners manual before operating this vehicle.

CAUTION

This utility vehicle comes equipped with a Low Oil Indicator Light located on the dash panel in the center of the vehicle. This light will come on when the key is turned to the “on” position, and then go off after the engine is started. While operating the vehicle if the oil light becomes illuminated immediately turn the key to the “off” position to kill the engine.

This utility vehicle is not equipped with any underseat storage.

This vehicle comes standard with 25”x11” -12” off road tires. To compensate braking with the larger tires, the front hydraulic system is equipped with 8” rotors. The rear is the standard hydraulic drum setup.

Section 5 Maintenance

Fuel Type

The fuel tank is located under seat.

TW11, TW 413, CW11, CW413 Fuel Capacity is 5 Gal.

CW-265 & TW265 Fuel capacity is 1.6 Gal.

When filling the fuel tank, place the gear shift in forward or reverse, set the park brake, turn off the engine, and remove ignition key. Clean dirt from around the fuel tank cap, remove cap, and begin filling. When finished, screw the cap back on securely and wipe up any spilled gasoline. Use regular unleaded gasoline with an octane rating of 87 or higher.

IMPORTANT: Never use methanol, gasoline containing methanol, or gasohol containing more than 10% ethanol because the fuel system could be damaged. Do NOT mix oil with gasoline.

Using a fuel stabilizer/conditioner in the vehicle can provide benefits such as:

- * Keeps gasoline fresh during storage of 90 days or less. For longer storage, drain the fuel tank.
- * Cleans the engine during operation.
- * Eliminates gum-like varnish build-up in the fuel system.

Add the correct amount of gas stabilizer/conditioner to the gas. Follow the gas stabilizer/conditioner manufacturer's directions for best results.

See engine operator's manual for the following:

- * Draining the fuel tank.
- * Checking fuel line for cracks and leaks.
- * Engine fuel valve lever.

Engine Maintenance

General Information

Detailed instructions and recommendations for break-in and regular maintenance are specified in the engine operator's manual. Engine warranty is backed by the engine manufacturer. Please refer to engine manufacturer's manual for engine servicing, lubricating oil levels, oil quality and viscosity recommendations, bolt torques, etc. Special attention should be paid to applicable data that is not duplicated here.

Engine Fuel Valve Lever

Refer to Figure 5-1

The engine fuel valve opens and closes the passage between the fuel tank and carburetor. Leave fuel valve lever in the OFF position when the engine is not in use to prevent carburetor flooding and reduce possibility of fuel leakage into the cylinder cavity and engine oil reservoir. Turn fuel valve lever to the ON position when running the engine.



Figure 5-1

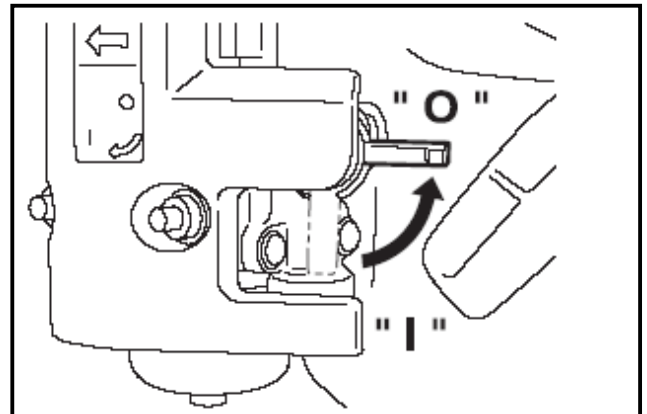

Section 5 Maintenance

* **Foam element** – Clean foam element with detergent in warm water or in a nonflammable solvent. Do not wring element. Squeeze excess cleaning fluids out. Allow time for the element to dry and then soak it with clean engine oil. Squeeze excess oil out. Excess oil left in the filter will cause engine to smoke briefly when first started.

Before installing the filter elements to make sure they have not been damaged during cleaning. Never run an engine without the filters installed.

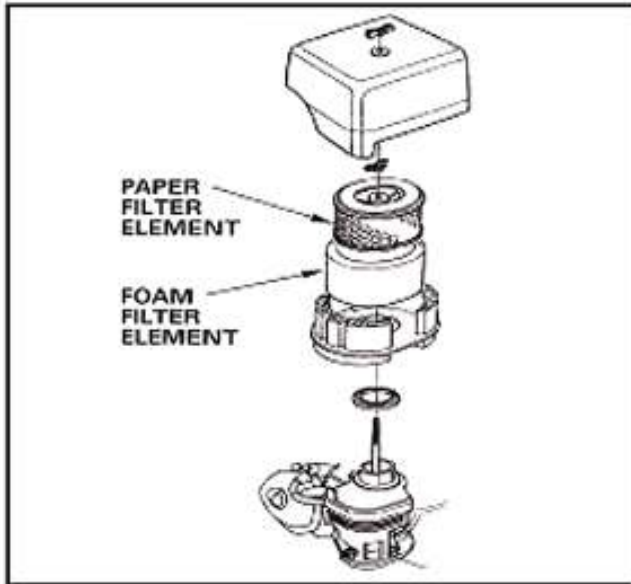

Figure 5-2

Spark Plugs

HONDA

NGK	BPR6ES
CHAMPION	RN9YC
AUTOLITE	4263 / 63
DENSO	W20EPR-U

SUBARU 265cc

NGK	BR6HS
CHAMPION	RLH6C

SUBARU 653cc

NGK	BPR2ES
-----	--------

Air Filter Elements Replacement Parts

<u>Description</u>	<u>Part No.</u>
Honda	
Paper Filter Element	17210-ZE3-000
Honda	
Foam Filter Element	17210-ZE3-010
Subaru	
Paper & Foam Element (265cc)	279-32607-07

Fuel Hose – Inspect fuel hose monthly for cracks, leaks or other damage. Replace immediately if any damage is suspected.

Section 5 Maintenance

Engine Oil

A general description for engine oil maintenance, recommendations, and capacities is provided below. See Engine Operator's Manual for a detailed description.

Note: Running engine low on oil can cause engine damage and void engine warranty.

Note: Overfilling of oil level can cause loss of power, engine damage and void engine warranty.

Engine Oil Fill and Drain Locations

Refer to Figure 5-4

REMOVE SEAT (and plastic tray if equipped) FOR EASY ACCESS

- **Filler cap/dipstick location: At front of engine**
- **Drain plug location: At rear end of engine**
- **Type of Lubrication: SAE 30**
- **API classification of SJ, SL or Equivalent**
- **Honda Oil Capacity: 1.16 US qts. /1.1 liters**
- **Subaru 265cc Oil Capacity: 1.1 US qts. / 1.0 liters**
- **Subaru 653cc Oil Capacity: 1.64 US qts./ 1.55 liter**

Engine Oil Maintenance Schedule

* Check oil level after each use.

* Make first oil change after the first month of operation or at 20 hours of operation (whichever comes first).

* Make all subsequent oil changes every 6 months or every 100 hours of operation (whichever comes first).

Engine Oil Level Check

Refer to Figure 5-4

Check engine oil daily with filler cap/dipstick located at the engine rear end as follows:

1. Park Vehicle on a level surface, set park brake, turn off ignition switch, and remove switch key.
2. Remove filler cap/dipstick and wipe it clean.
3. Insert and remove dipstick without screwing it into the fill neck. Check oil level shown on dipstick.
4. Fill to edge of oil fill hole with recommended oil when oil levels are low.

5. Replace filler cap/dipstick and tighten securely.

Engine Oil Change

Warm oil drains quickly and completely. Therefore, drain used engine oil while engine is still warm as follows:

1. Park vehicle on a level surface, set park brake, turn off ignition switch, and remove switch key.
2. Place a suitable container below engine to catch used oil. Remove filler cap/dipstick and drain plug.
3. Allow used oil to drain completely and then reinstall and tighten drain plug securely.
4. Dispose of used motor oil in a manner that is compatible with the environment. Do not throw used oil in the trash. Do not pour it on the ground, or down a drain.
5. Fill oil to the outer edge of the oil fill hole with recommended oil. Engine must be level when filling.
6. Replace filler cap/dipstick and tighten securely.

SPECIAL NOTE: TO DRAIN ENGINE OIL REMOVE REAR DRAIN PLUG ON ENGINE

Engine Oil Drain, Fill & Check Locations

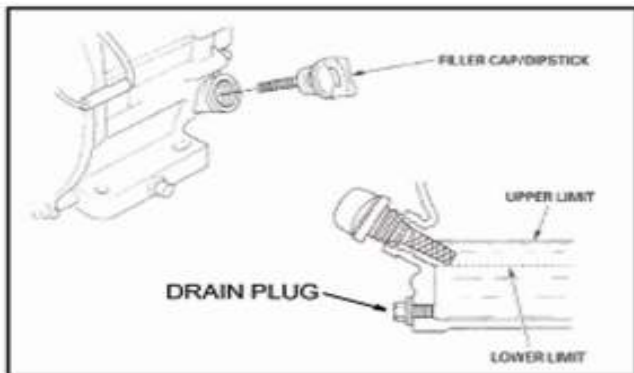

Figure 5-4

Section 5 Maintenance

Transaxle Oil

A general description for transaxle oil maintenance, recommendations, and capacities is provided below.

NOTE: Running vehicle low on transaxle oil can damage transaxle and void warranty.

Transaxle Oil Type, Fill, and Drain

Refer to Figure 5-5B

- * Fill cap location: At rear left hand side (See arrow)
- * Drain plug location: At bottom center of transaxle.
- * Type of Lubrication: SAE 30W oil.
- * Transaxle Lubrication Capacity: 20 oz.

Transaxle Oil Maintenance Schedule

* Check transaxle housing for damage and possible oil leakage after each use.

* Check transaxle oil level every 6 months or every 200 hours (whichever comes first).

This can be accomplished by Parking vehicle on a level surface, set park brake, turn off ignition switch, and remove switch key, using a clean long bladed screw driver (or similar object) insert into filler hole until it touches the bottom of gear case. Remove the screw driver. There should be approximately 2.1/4" to 2.1/2" of oil visible on screw driver. Refer to Figure 5-5A

* Change transaxle oil once a year or every 600 hours (whichever comes first).



Figure 5-5A

Transaxle Oil Change

Warm oil drains quickly and completely. Therefore, drain used transaxle oil while transaxle housing is still warm as follows:

1. Park vehicle on a level surface, set park brake, turn off ignition switch, and remove switch key.
2. Place a suitable container below the transfer case to catch used oil. Remove fill cap and drain plug.
3. Allow used oil to drain completely and then reinstall drain plug and tighten it securely.
4. Dispose of used transaxle case oil in a manner that is compatible with the environment. Do not throw used oil in the trash, pour it on the ground, or down a drain.
5. Fill transaxle housing with 20 oz. SAE 30W oil.
6. Replace fill cap and tighten securely.

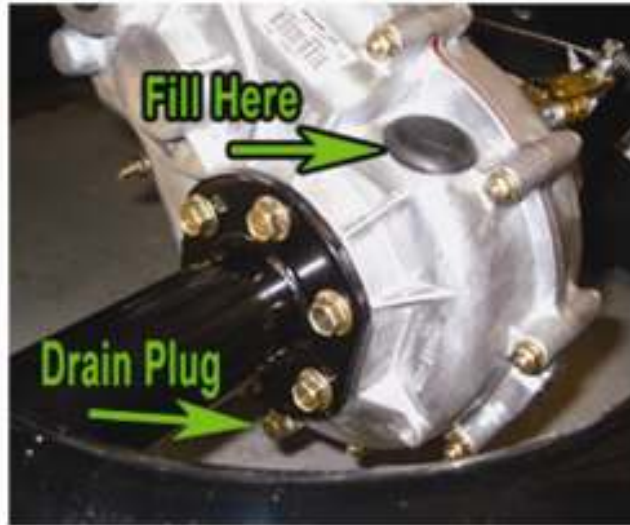

Figure 5-5B

Section 5 Maintenance

Drive Belt

The drive belt is considered a wearable item. Replacement intervals depend on vehicle use and environment. If your belt is slipping you may need to replace it.

1. Park vehicle on a level surface, set park brake, place shifter in Neutral, turn off ignition switch, and remove switch key.
2. Remove the upper belt covers. (It is not necessary to remove the bottom cover.)
3. "Walk" the belt off of the rear pulley as shown in Figure 5-6.



Figure 5-6

4. Install the new belt on the front pulley first and "walk" it onto the rear pulley.
5. **Reinstall** the belt guards. Figure 5-7.

Attention: Failure to reinstall the belt guards may void your warranty.



Figure 5-7

Section 6 Troubleshooting

Fuel in the Cylinder Cavity

In the event that the fuel valve is left open while transporting or towing this Utility Vehicle it is possible that fuel has leaked down into the cylinder cavity. If this has occurred the engine will not start. With the cylinder cavity full of fuel the engine will feel like it has “locked up”. Below are the proper steps to follow if your Utility Vehicle engine seems to have fuel in the cylinder cavity.

▲ WARNING

**Use EXTREME CAUTION when performing the activity below.
Gasoline is EXTREMELY FLAMMABLE!**

1. Move the vehicle to a well ventilated area, away from sparks or flame.
2. Park Vehicle on a level surface, set park brake, turn off ignition switch, and remove switch key.
3. Next, remove the wire connected to the spark plug. And remove the spark plug from the engine. (See Figure 6-1) (Spark Plug Wrench supplied with Operator’s Manual)
4. **WARNING:** Stand away from the spark plug hole when performing step 5. Fuel can spray several feet.
5. Wearing eye protection, slowly pull the recoil start grip handle (See Figure 6-2) in an upward motion. This should force the fuel out of the cylinder cavity through the spark plug hole. Caution: This gasoline spraying out of the cylinder cavity is very flammable, use extreme caution and make sure there are no sparks or flames nearby.
6. Repeat step 3 until only air escapes out of the spark plug hole.
7. Properly replace the spark plug back into the cylinder head, move the vehicle away from any spilled fuel. If there is fuel on the vehicle itself, allow for it to evaporate before continuing.
8. Connect the plug wire. Your Utility Vehicle is now ready to start.

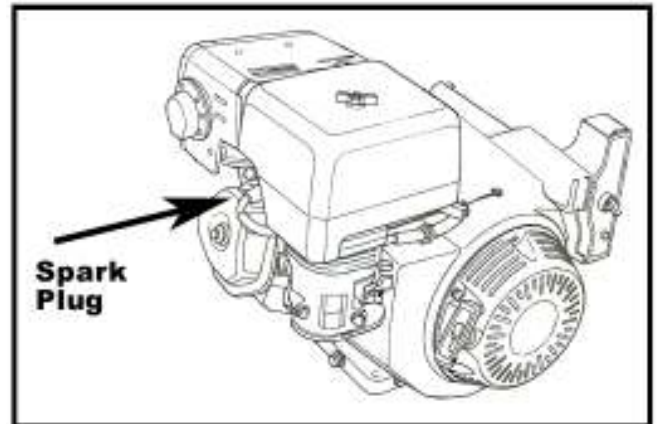

Figure 6-1

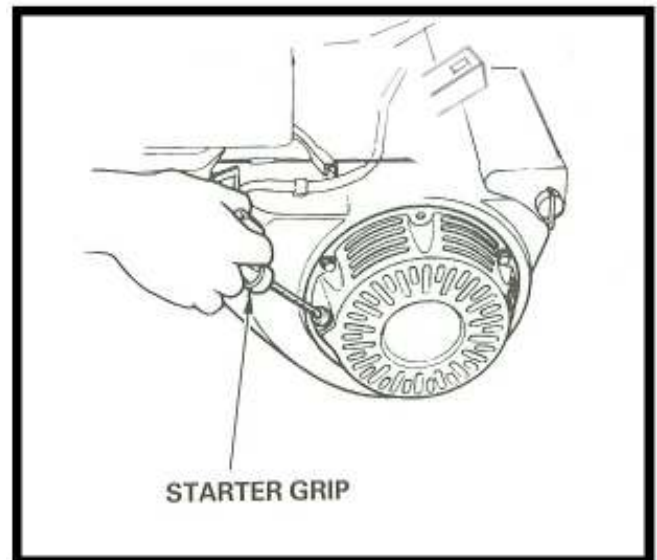

Figure 6-2

Section 6 Troubleshooting

Symptoms	Probable Causes	Suggested Remedies
Battery is dead	Key switch is not in the off position	Switch key to off position Disconnect and recharge battery
	Battery is worn out or defective	Replace battery
	Starter solenoid is shorted	Replace starter solenoid
Battery will not charge up	Battery connections are loose or corroded	Clean and tighten battery connections
	Battery fluid level is low	Add distilled water to battery cell
	Battery cell is dead	Turn key switch on and pull rope start to start engine. Replace battery as soon as possible
	Battery is worn out or defective	
Electrical System does not work	Electrical fuse is blown or missing	Replace electrical fuse
	Battery connections are loose or corroded	Clean and tighten battery connections
	Battery is worn out or defective	Replace battery
	Ignition switch is defective	Replace ignition switch
Engine backfires	Spark plug is fouled	Replace or clean spark plug
	Air intake restrictor upstream of air cleaner is missing or incorrectly installed	Replace or correctly install air intake restrictor
	Throttle cable is defective or out of adjustment	Clean and oil throttle cable. Replace worn or damaged cable
Engine knocks	Engine speed is set too low	Adjust engine idle screw
	Engine is overloaded	Avoid overloading the engine
	Fuel is stale or dirty	Replace fuel with new fuel

Trouble Shooting

Steering feels funny/pulling to one side/hard to steer (Call normally for 4wd)

Probable Cause:

- One side may still be engaged in 4wd with the switch off.

Possible Remedy:

- Put unit in reverse and back up straight a few feet to get the axle to release.
- If this does not work take the unit to a service center.

Engine Shuts down when turning or on inclines or uneven terrain-

Probable Cause:

- Oil is low or Honda oil sensor is bad

Possible Remedy

- Check oil level with unit on level ground-Adding more oil or making sure the oil is completely full can help to not alert the low oil sensor.
- Honda Low oil alert sensor may be bad and must be replaced by authorized Honda service center.

Engine will not start but does turn over with electric starter.

Probable Cause

- Fuel valve may be off, spark plug may be fouled (excessive idling or running unit with choke engaged can cause plugs to foul), or engine oil may be low.

Possible Remedy

- Make sure fuel valve is on.
- Replace spark plug and try to restart.
- Check oil level with unit on level ground-Adding more oil or making sure the oil is completely full can help to not alert the low oil sensor.

Engine will not start and does not turn over with electric starter.

Probable Cause

- Shifter is not in neutral, battery may be low or bad, neutral switch on transmission may be unplugged or bad, key switch or its connections connectors may be unplugged or bad, electric starter may be bad.

Possible Solutions

- Shifter must be in neutral
- Turn key to on position and use recoil start
- If this works recharge or replace the battery
- Check neutral switch on transmission to make sure it is plugged in.
- Check all connections to key switch (switch may be unplugged behind fire wall).
- Key switch may be bad-switch must be changed out with new one
- Have authorized Honda Service Center check the electric starter

Gas in oil

Probable Cause

- Unit may have been transported with fuel valve on. Every time a unit is transported on a trailer or in a truck the fuel must be shut off using the shut off valve on the side of the engine. Leaving this valve open during transport could allow fuel to be deposited into the crank case locking the engine up.

Possible Solution

- Oil in engine must be drained completely and changed with fresh oil
- Run unit and check oil again –if no gas is found in oil-unit is ready.
- SEE PAGE 19 of this manual for instructions

Brakes don't work well / Hard to push / no travel in pedal

Probable Cause

- The brake rotors are dirty.

Possible Solution

4x4 units

- Clean the rotors with brake cleaner and test.
- A stiff pedal is normal for our 4x4 unit-
- A stiff pedal means good pressure in the brake lines
- Check brake pads and front calipers

2wd units

- The 2wd units have an automatic brake adjuster. Put the unit in reverse, back up at low speed, and step hard on the brakes. This should give enough brake adjustment.

If you continue to have problems, discontinue use and take it directly to an authorized service center

Belt slipping/will not pull up hill

Probable Cause

- Too much weight (hauling/towing excessive weight can cause belt to slip).
- The belt is wet
- The torque converter pulleys are dirty.
- Belt may have stretched or have a low spot causing slipping-replace belt

Possible Solution

- Lighten the load.
- Clean the torque converter and dry the belt
- Replace the belt

American SportWorks Utility Vehicle Shifter Trouble Shooting

Notice: Always check transmission oil level. Dip a clean screwdriver straight down in the fill hole to the bottom of the gear case. There should be about 2 ½ inches of oil on the screw driver. If oil needs to be added, use SAE 30 motor oil. See Page 19 for Instructions

- Engine will not turn over when key is turned to start. – This vehicle is equipped with a safety switch that only allows starting in neutral.
Go to **Neutral switch diagnostic procedure.**
- Gears grind when going into a gear or vehicle stays in gear when shifted to neutral. – Cables need to be lubricated or adjusted.
Go to **Cable adjustment procedure.**

Neutral switch diagnostic procedure

If starter does not engage when shift lever is in neutral:

1. Apply the parking brake.
2. Turn and hold the key to start. – “Jiggle” the shift lever in the neutral slot. If the starter engages, release the key and call American SportWorks Customer service to order a neutral switch shim kit.
3. If the starter did not engage in step 2, turn and hold the key to start – slowly move the shift lever from neutral to reverse – if the starter engages, release the key. Repeat, moving the shift lever from neutral to forward.
 - If the starter did engage, go to **Cable adjustment procedure** section.
 - If the starter did not engage call Customer Service at 1-866-646-5278.

Cable adjustment procedure

Stiff or sticking cables can cause the vehicle to not shift properly and it may affect starting since the vehicle must go to neutral to start. Before attempting to adjust the cables there are several steps that can be taken to insure the cables are operating properly.

- Lubricate the cables. Behind the dash board there are two cables attached to the gear selector lever. Slide the rubber dust caps up the cable. Drip or spray penetrating oil into the cable housing while working the lever. Do this several times as the oil soaks into the housing. Test the vehicle. If this did not help move to the next step.
- Remove the center console (with cup holders). Find the shifter cables and cut the plastic ties that fasten them to the frame tube. Over tight cable ties can cause the cable to bind. Replace cable ties but leave them loose so that the cable can move in them. Test the vehicle. If it is still not performing correctly, move to the adjustment procedures that follow.

Vehicles with serial number less than 17063.

(See brass tag near top of left rear shock absorber)

1. Loosen the cable adjusters behind the dash board. (photo on left)
2. Place the selector lever on the dashboard in forward.
3. Make sure the transmission is fully engaged in forward. The top of the shift lever on the transmission should be toward the passenger side. You may have to roll the rear wheels a little until it clicks in.
4. Pull the slack out of the forward most cable under the dash (but do not stretch the spring) and tighten the adjuster nuts.
5. Place the selector lever on the dashboard in reverse.
6. Make sure the transmission is fully engaged in reverse. The top of the shift lever on the transmission should be toward the passenger side. You may have to roll the rear wheels a little until it clicks in.
7. Pull the slack out of the rear most cable under the dash (but do not stretch the spring) and tighten the adjuster nuts.

If you have tried all of this and it is still not operating correctly, you may need new cables and a shifter update kit. Please call American SportWorks Customer Service at 1-866-646-5278. Have your Model and Serial number handy when you call.

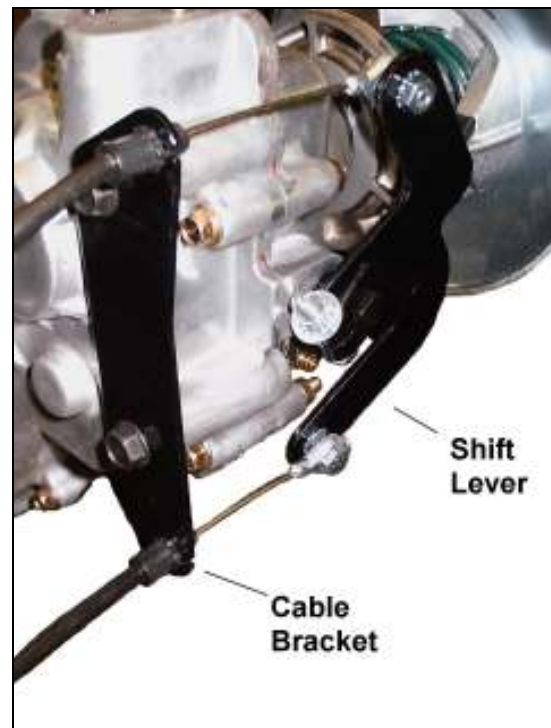

Vehicles with serial number greater than 17063.

(See brass tag near top of left rear shock absorber)

1. Put the vehicle in neutral.
2. Loosen the cable adjusters behind the dash board. (photo on left)
3. Make sure the selector lever on the dashboard is in neutral.
4. Make sure the transmission is in neutral. You can check by turning the key to Start. The engine will only turn over if the transmission is in neutral.
5. Pull the slack out of both cables (but do not stretch the springs) and tighten the adjuster nuts.

If you have tried all of this and it is still not operating correctly, you may need new cables. Please call American SportWorks Customer Service at 1-866-646-5278. Have your serial number handy when you call.

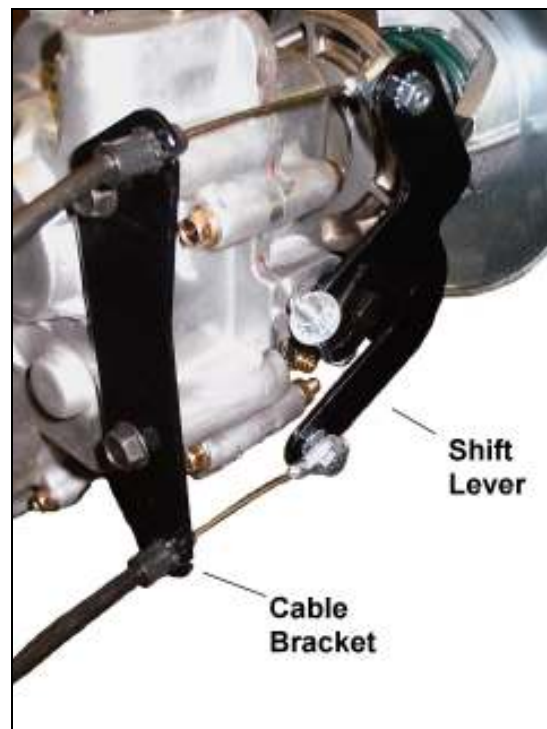

Section 7 Parts Diagrams

Wiring Diagram HONDA Engine Models

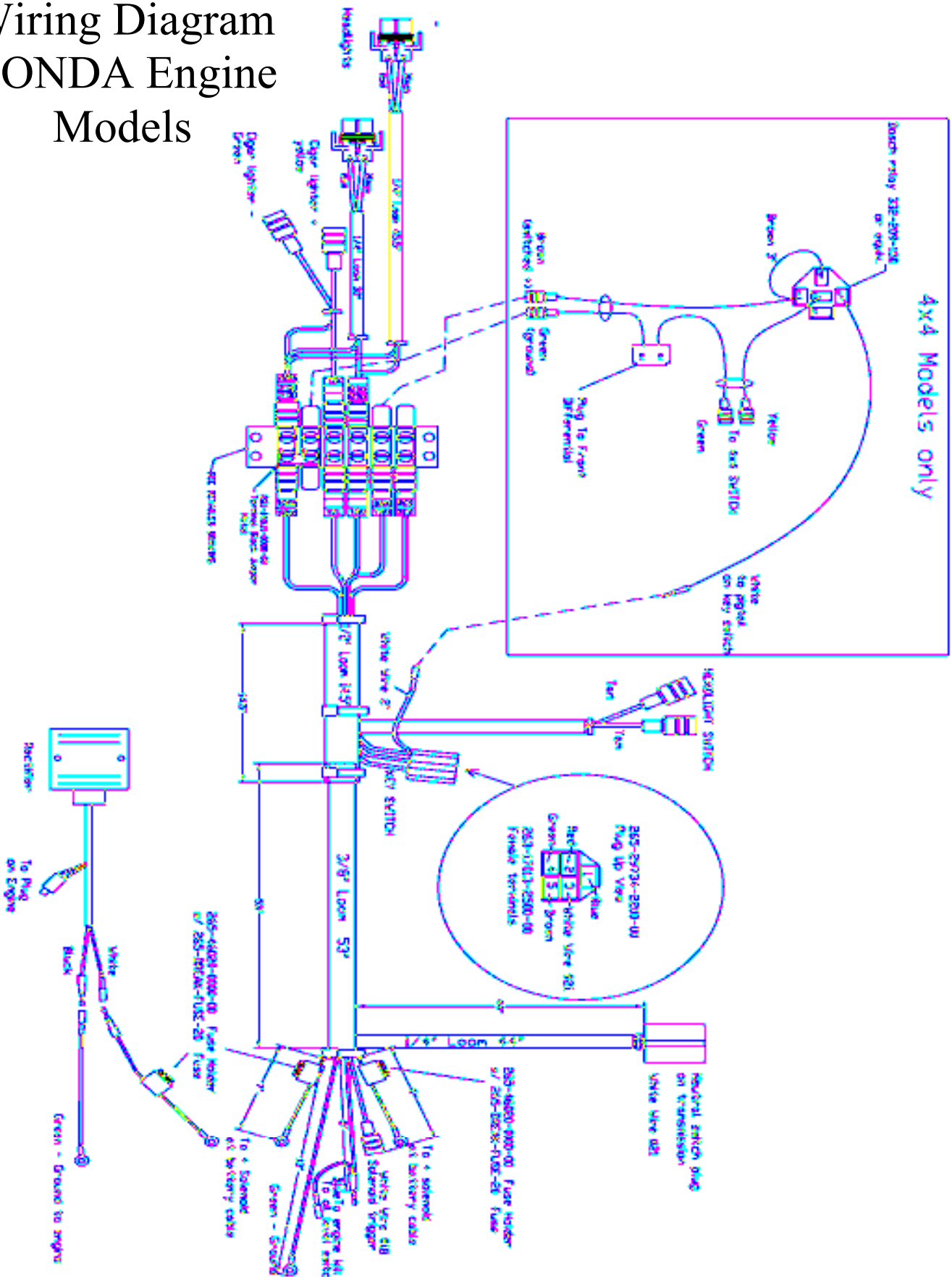

Wiring Diagram SUBARU Engine Models

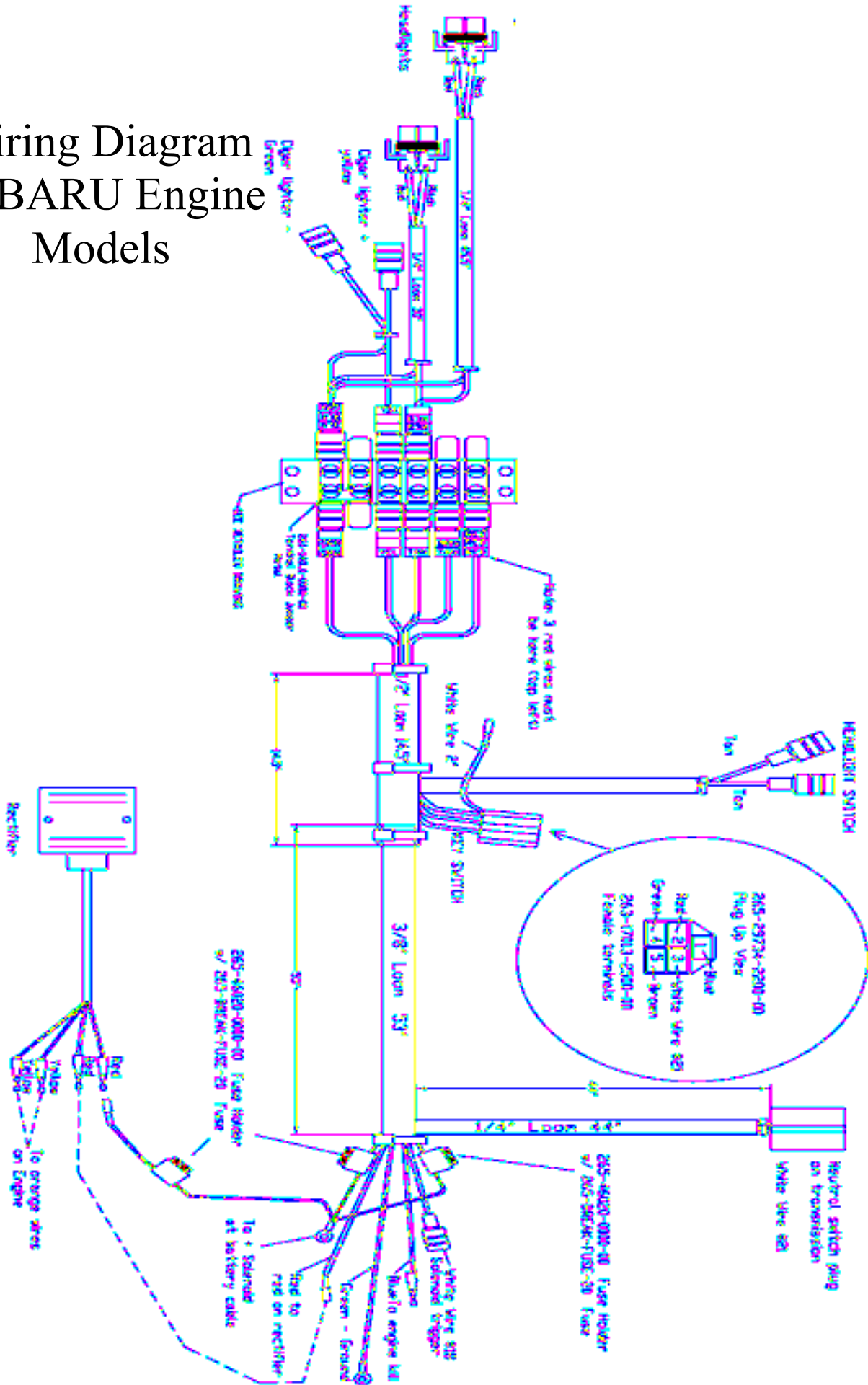

Terminal Block Wiring

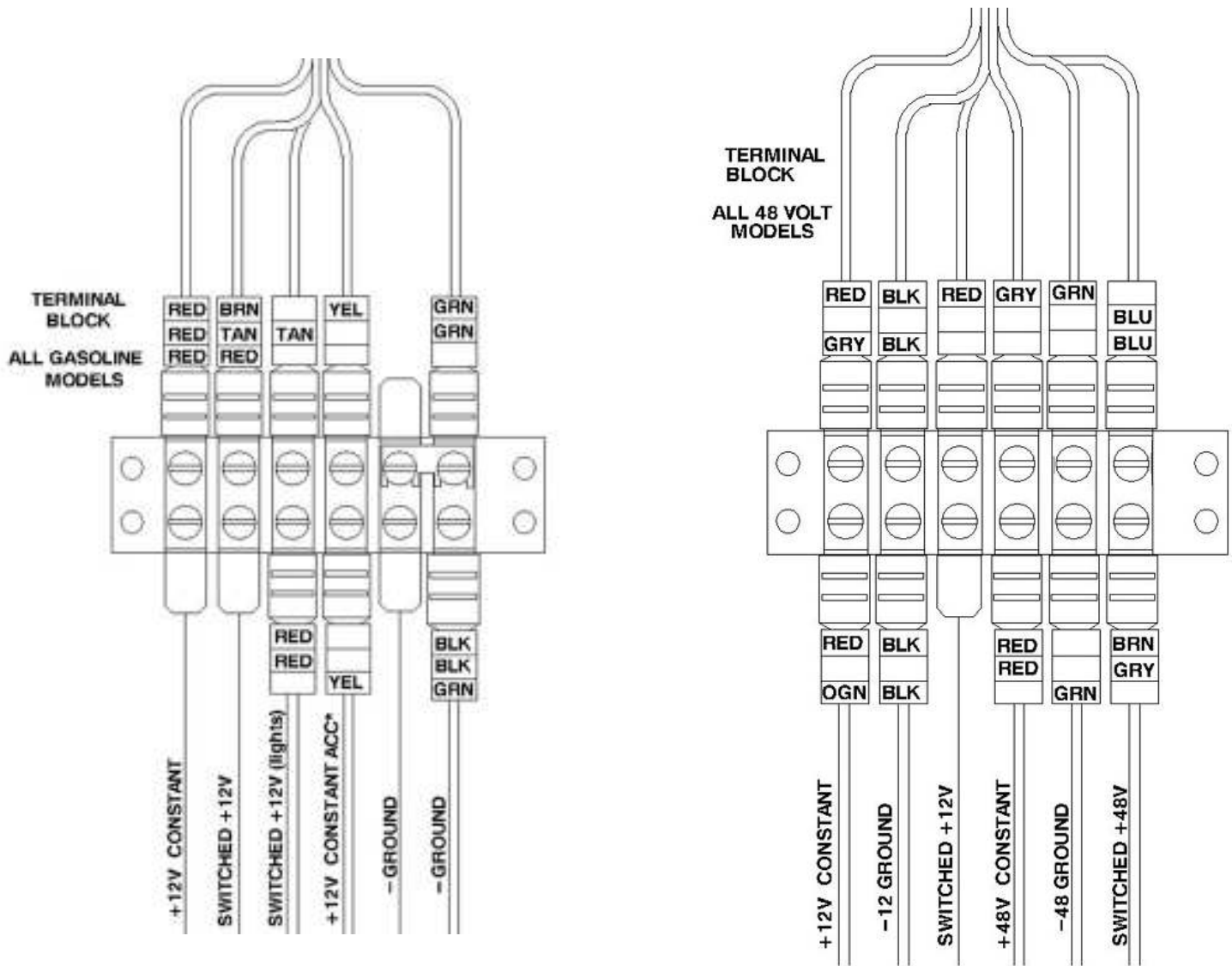

2 Wheel Drive Dana Transaxle Parts Breakdown



SPICER OUTDOOR POWER EQUIPMENT COMPONENTS DIVISION

DANA CORPORATION

FREDERICKTOWN, OH 43019

SERVICE PARTS REPLACEMENT LISTING

MODEL NO.: 012AJ396-1

DATE ISSUED: 12/13/2004

DESCRIPTION: Axle Assembly, Rear (FNR W/ Diff Lock)

<u>Key No.</u>	<u>Dana Part No.</u>	<u>No. Req'd.</u>	<u>Description</u>
1	012CH345-X	1++	Housing, Axle (W/ Idler Shaft)
2	012CH320	1++	Housing, Axle, Finished
3	012LK133	1	Kit, Detent
4	012HH122	1	Seal, Oil
5	012GV164X	1	Assembly, Actuator
6	012SV118X	1	Assembly, Shift Rod
7	012HH128	3	Seal, Oil
8	012TA372-1X	1	Assembly, Tube
9	012TA373-1X	1	Assembly, Tube
10	070HM282	6	Screw, Flange Head
11	070HM251-1	8	Screw, Socket Head
12	840293	4	Ring, Retaining
13	012HD106	2	Bearing, Ball
14	500024-6	2	Pin, Cotter
15	012WD116-1X	1	Assembly, Brake
16	012WD116-2X	1	Assembly, Brake
17	34617	2	Seat, Spring
18	070HN218	8	Nut, Lock
19	012HN127	2	Nut, Hex Flange
20	012SR170-1	1	Shaft, Axle
21	012HM132-1	8	Bolt, Wheel
22	012WA123	2	Drum, Brake
23	012HU137X	2	Assembly, Hub, Wheel
24	012HM110-1	11	Screw, Flange Head
25	012HM110-2	2	Screw, Flange Head
26	012HN120	13	Nut, Lock
27	41356	1	Plug, Rubber
28	012HN140	1	Vent
29	012HP120	2	Pin, Dowel
30	585965	1*	Bearing, Ball
31	012GS307	1**	Shaft, Input
32	012LK134	1+	Kit, Shim
33	012HD111	1*	Bearing, Ball
34	012HD129	2*	Bearing, Ball
35	012HS121	2	Spacer, Flat
36	012HS126	1	Washer, Thrust

Please contact our Customer Service Department (866-646-5278)
To special order DANA Transaxle Parts

Key No.	Dana Part No.	No. Req'd.	Description
37	012HS125	1	Washer, Thrust
38	012GS202X	1**	Gear Assembly, Forward
39	012GS302	1	Gear, Clutch
40	012GS200	1	Shaft, Intermediate
41	012GS204X	1**	Gear Assembly, Reverse
42	012GS215	1**	Gear, Helical (Pinion)
43	012GS207X	1**	Gear Assembly, Idler
44	012HR128	1	Ring, Retaining
45	585994	1*	Bearing, Ball
46	012GS216	1**	Gear, Helical (Ring)
47	012KD129	1	Assembly, Differential
48	012HN138	4	Nut, Lock
49	012HM129	4	Bolt, Hex
50	026HS104	1	Gear, Clutch, Diff Lock
51	012CH319	1++	Housing, Diff Lock
52	3112	1	Seal, Oil
53	012SV117X	1	Assembly, Shift Shaft
54	314004	1	Lever, Actuating
55	4150221	1	Screw, Hex Head
56	4150223	1	Nut, Lock
57	012HD142	1*	Bearing, Ball
58	012SR171-1	1	Shaft, Axle
59	012HM137	6	Screw, Flange Head
60	5803	1	Switch
62	026HP100	2	Bushing – Dowel
63	012HG145	1	Drain Plug

* - These Ball Bearings are available packaged together as a kit. Order Dana number 012KD124 for this kit.

** - The Internal Gears are available packaged together as a kit. Order Dana number 012KG106 for this kit.

+ - Use Shim(s) as required to maintain proper clearances.

++ - Sealant is to be applied between Left Hand and Right Hand Axle Housings. Sealant is to be applied between right hand axle housing and diff lock housing. Use Loctite Gasket Eliminator No. 518 or equivalent.

Please contact our Customer Service Department (866-646-5278)
To special order DANA Transaxle Parts

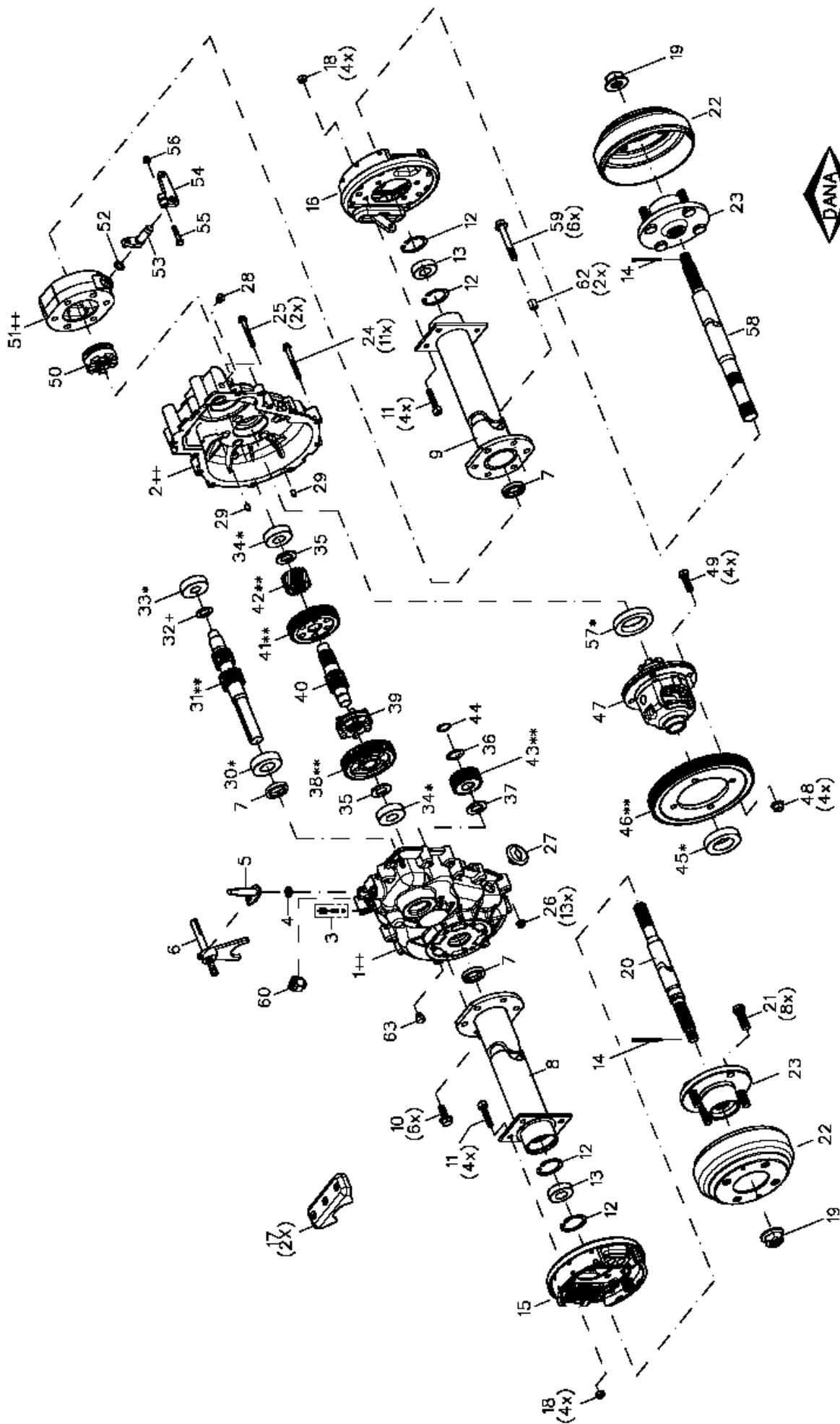

DANA CORPORATION
 SPICER OUTDOOR POWER
 EQUIPMENT COMPONENTS DIVISION

MODEL 012AJ396-1

265cc
CW265/ TW265/ BD300
Utility Vehicle
Parts Breakdown

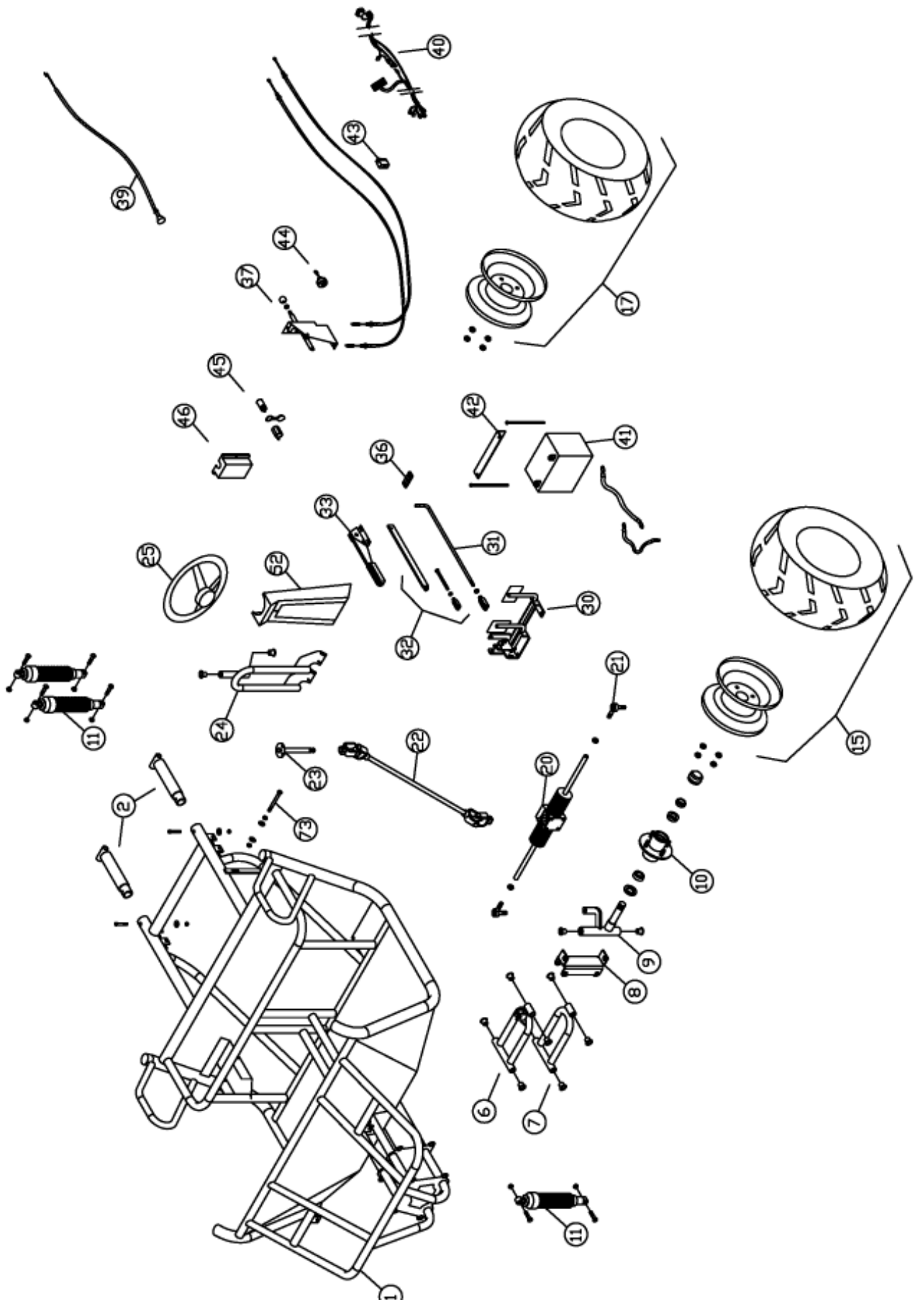

Frame
265cc Models

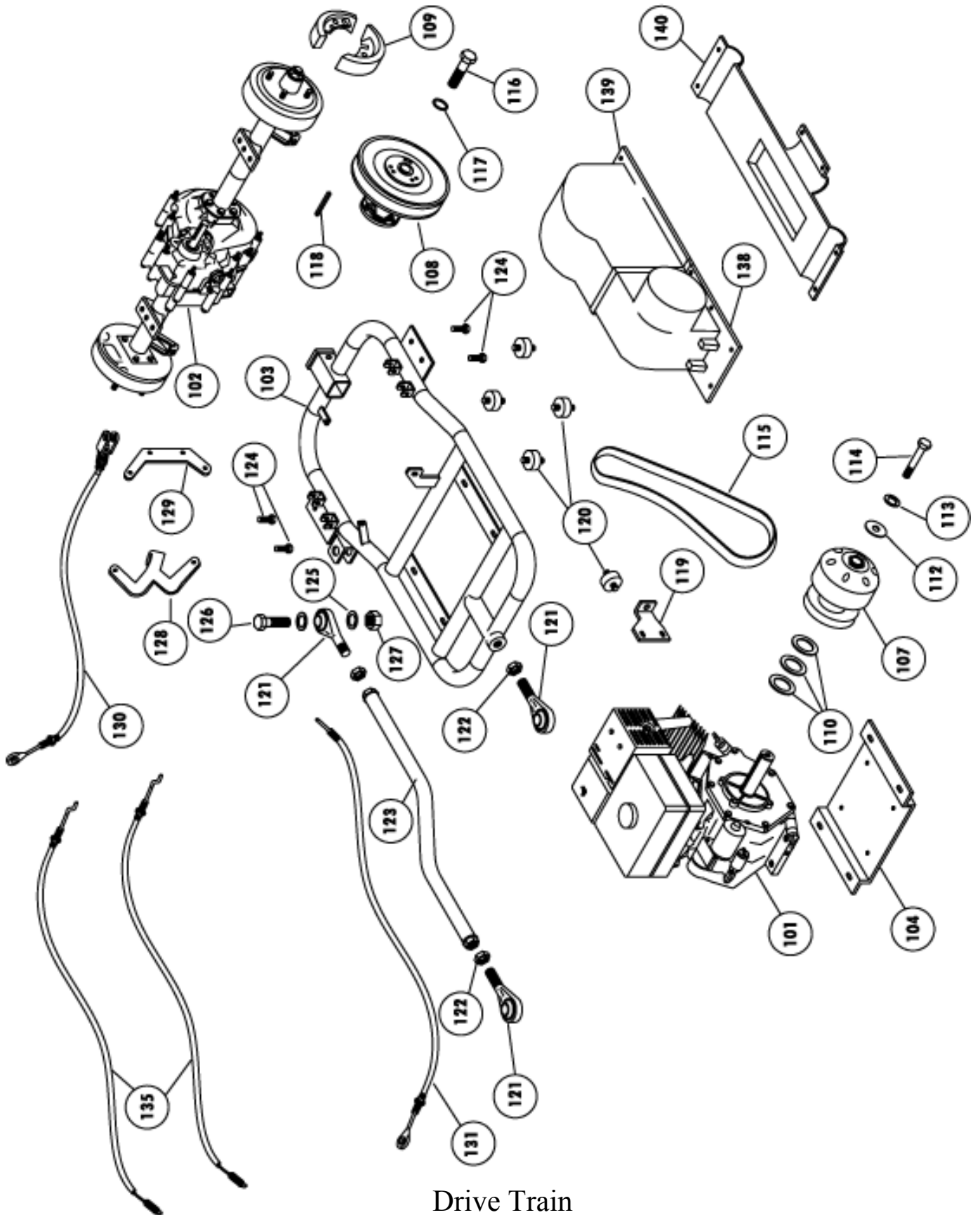

Drive Train
265cc Models

Reference Number	Part Number	Part Description – 265cc 2WD Models	Quantity Required
1	45419	Frame, CW11	1
2	45401	Rear frame stub, CW - black	2
	50168	5/16 x 2-1/4" USS Socket Head bolt	2
	50007	nut, 5/16 nylock	2
	50702	bent washer 5/16	2
3	45413	bumper, CW - black	1
	45432	Bumper, Trail Wagon – Black	1
	50167	bolt, 5/16 x 2	4
	50007	nut, 5/16 nylock	4
	50702	bent washer 5/16	4
	70208	Vinyl Caps 1 3/4 x 1 1/2	2
4a	45412	Brush Guard roof, CW265 – black	1
4b	42300	Brush Guard roof, TW265 – black	
	50168	5/16 x 2-1/4" USS Socket Head bolt	4
	50007	nut, 5/16 nylock	4
	50702	bent washer 5/16	4
5	45411	brshgrd seat back, CW – black	1
	50168	5/16 x 2-1/4" USS Socket Head bolt	2
	50007	nut, 5/16 nylock	2
	50702	bent washer 5/16	2
6	43010	A-arm upper, 265 – black (left or right)	2
	51100	suspension bushings	4 ea
	50262	bolt, 5/8 x 9"	1 ea
	50254	Bolt, 5/8 x 3.5 bolt	1 ea
	50015	Nut, 5/8 nylock	2 ea
7	43011	A-arm Lower, 265 – black (left or right)	2
	51100	suspension bushings	4 ea
	50262	bolt, 5/8 x 9"	1 ea
	50254	Bolt, 5/8 x 3.5 bolt	1 ea
	50015	Nut, 5/8 nylock	2 ea
8	45408	spindle mount, CW – black	2
9a	45406	Spindle, left – black	1
9b	45407	Spindle, right – black	1
	51100	suspension bushings	2 ea
	50262	bolt, 5/8 x 9"	1 ea
	50015	Nut, 5/8 nylock	1 ea
10	30604	Hub, 4 bolt high speed 1" Complete with Bearings & Seals	2
	11205	bearing, 1" tapered	
	30620	seal	

Reference Number	Part Number	Part Description – 265cc 2WD Models	Quantity Required
	30623	dust cap	
	30622	castle nut, 1”	
	30621	cotter pin	
	50060	Lug nuts, ½”	
11	70301	Shock, Heavy duty #1	6
	50400	Bolt, 10 mm x 40mm	12
	50065	Nut, 10mm nylock	12
15L	30142	Rim/Tire Assembly, UTV 22/11-8” Front Left	1
15R	30143	Rim/Tire Assembly, UTV 22/11-8” Front Right	1
17L	30144	Rim/Tire Assembly, UTV 22/11-8” Rear Left	1
17R	30145	Rim/Tire Assembly, UTV 22/11-8” Rear Right	1
20	10596	Rack & pinion with rod ends 265	1
	10593	Rack & Pinion Boots	2
	N/A	Rack & Pinion Rod – 265 – Not available sold as assembly only	
	50171	Bolt, 5/16 x 3 ¾” USS	4
	50005	Nut, 5/16 keps	4
	50063	Nut, ½” SAE nylock	2
21	10524	Rod end “ use before serial #27214”	2
	10597	Rod end “ use after serial #27213”	2
	50078	Nut, ½” SAE jam	2
22	10522	Steering Shaft w/u-joints	1
	50402	Bolt, 10mm x 30mm	1
	50066	Nut, 10mm Tri Lock Jam	1
	50403	Bolt, 8mm x 30mm	1
	50780	Lock washer, 8mm	1
23	45422	Steering Stub Shaft Assembly, CW – Black	1
24	45400	Steering support, CW – black	1
	51100	suspension bushings	2 ea
	50152	bolt, 5/16 x 1	4
	50005	Nut, 5/16 keps	4
25	10502	Steering Wheel 13”	1
	10506	Center cap	
		screw, included with center cap	
	50081	bolt, ¼ x 1 ¾	3
	50001	nut, ¼ nylock	3
30	45402	Pedal assembly, CW – black	1
	50152	bolt, 5/16 x 1	6
	50081	bolt, ¼ x 1 ¾”	1
	50159	bolt, 5/16 x 1 ½	1
	50005	Nut, 5/16 keps	8
	50701	Washer, 5/16 flat	2

Reference Number	Part Number	Part Description – 265cc 2WD Models	Quantity Required
31	11181	Brake Rod, with clevis	1
	50215	bolt, 3/8 x 1 ¼	1
	50010	nut, 3/8" nylock	1
	50801	cotter pin 1/8" x 1	1
32	45417	parking brake bar, CW – black	1
	50806	Clevis, 5/16 rod end	1
	50170	Bolt, 5/16"-24 X 4" SAE	1
	50077	Nut, 5/16" Hex SAE	1
	50087	bolt, ¼" x 1	1
	50001	nut, ¼" nylock	1
33	11127	Parking Brake	1
	50086	Bolt, ¼ x 1 ¼	1
	50001	nut, ¼" nylock	1
	50163	bolt, 5/16 x ¾" NC	4
	50005	Nut, 5/16 keps	4
	50701	Washer, 5/16 flat	4
36	45415	Brake equalizer, CW (2 ½") – black	1
	50215	bolt, 3/8 x 1 ¼	2
	50010	nut, 3/8" ny-lock	2
37	11085	Shifter control assembly, black (built after 2-1-05)	1
	11083	Knob	1
	11082	Cable, shifter (built after 2-1-05)	2
	11080	Shifter Cable and Shifter Control (built before 2-1-05)	1
	50053	nut, #10-24 Keps nut	2
	50616	screw, #10-24 X ¾" Pan Head Phillips	2
	50770	Washer, #10 flat	2
40	70053	Wire Harness – 265	1
41	70000	Battery, U1L-HDJ7-UTV - 360CCA	1
	70002	Battery Cable, Red – 17"	1
	70010	Battery Cable, Black (24")	1
	70009	Battery Terminal Cover	2
	50087	bolt, ¼" x 1	2
	50000	nut, ¼" keps	2
42	45414	Battery strap, CW (8 ¾") – black	1
	50083	bolt, ¼ x 7 ½	2
	50002	nut, ¼" wing	2
43	70055	Light Switch	1
44	70052	Key Switch	1
	70060	Key, 1 pair	
45	70080	Accessory Plug	1
	70081	Accessory Plug cap	1

Reference Number	Part Number	Part Description – 265cc 2WD Models	Quantity Required
46	18500	Terminal Block Cover – plastic	1
	50625	screw, #10-24 X 1" Pan Head Phillips	2
	50053	nut, #10-24 Keps nut	2
47a	70129	Headlights CW265 – oval	2
47b	70133	Headlights TW265 – rectangular	2
	70055	Switch Headlights	1
50a	18302	Hood, plastic Red CW265	1
50b	18350	Hood, plastic Yellow TW265	1
	18387	TW265 grill	1
	18389	TW265 headlight bucket - left	1
	18388	TW265 headlight bucket - right	1
	50620	¼" X 1 ¼" Pan Head Phillips Machine screw	2
	50621	¼" X 2" Pan Head Phillips Machine screw	2
	50717	¼" SAE Flat washer	8
	50001	nut, ¼" nylock	4
	50846	Clamp-Tube-vinyl coated 1-1/4"	2
51	18309	Glove Box	1
	50624	Screw, #10 x ¾ hex – black	5
52	18308	Steering Cover	1
	18317	Steering Cover Bottom	1
	50624	Screw, #10 x ¾ hex – black	1
53	18306	Center Console	1
	50624	Screw, #10 x ¾ hex – black	14
54	18316	Access Cover, Center Console	1
	50624	Screw, #10 x ¾ hex – black	4
55	18305	Plastic, Seat Bottom wrap	1
	50624	Screw, #10 x ¾ hex – black	5
57	18303	Rear Fender CW only	1
	50001	nut, ¼ nylock	4
	50091	¼"-20 X ¾" Carriage bolt	4
	50717	¼" SAE Flat washer	4
	70150	Reflectors	2
60	10754	Seatback 43 ½ x 17 ½	1
	50619	#14 X 1-3/4" Pan head-Tapping screw	6
61	10803	Headrest – UTV 9 x 6 ½	2
	50085	bolt, ¼ x 1 ½"	4
62	10755	Seat bottom 43 ½ x 17 ½	1
63	45416	seat bar, CW (17 ½") – black	2
	50609	#14 x ¾ Pan Head Screw	6
65	10705	Seat Belt, 2pt	2
	50025	7/16 Nylock	4

Reference Number	Part Number	Part Description – 265cc 2WD Models	Quantity Required
70a	45420	Cargo Bed, Red CW265	1
70b	45434	Flat Cargo Bed, Black - TW265	1
	50255	5/8 x 4" bolt Zinc plate	2
	50015	5/8 nylock	2
	18402	Bed Rubber Plug	2
73	50208	Bed latch bolt, 3/8 x 2 1/2"	1
	50013	nut, 3/8 keps	2
	50740	washer, 3/8 flat	2
75	45421	Tail gate, Red	1
	50152	bolt, 5/16 x 1	2
	50701	washer, 5/16 sae	4
	50007	nut, 5/16 nylock	2
	70230	rubber bump stops	4
78	50815	1/4" Lynch Pin - tailgate latch	2
101	20016	Engine, Subaru 265cc	1
-	50202	3/8-16 x 1 3/4" Hex Hd Bolt	4
-	50740	3/8" Flat washer, USS	4
102	20869	Dana Transaxle – 265 models	1
	70057	Neutral Safety Switch	1
	51500	Shims – Neutral Safety Switch	
103	45423	Swing arm, CW - Black	1
104	45430	Motor Plate, CW - Black	1
107	20667	TC, Driver Comet 40	1
	20665	TC, Driver CVTECH – used after Serial Number # 42439	1
108	20668	TC, Driven Comet 40	1
	20666	TC, Driven CVTECH – used after Serial Number # 42439	1
109	11171	Brake Shoes - Rear UTV 2WD – Dana – 1 Set required for each wheel	2
110	51101	265 Crankshaft Spacer	1
112	50795	7/16" I.D. Fender Washer	1
113	50793	7/16" Lock Washer	1
114	50302	7/16 x 2 1/2 SAE Bolt	1
115	20693	Belt, Comet 300668	1
116	50239	1/2 x 2" SAE	1
117	50722	1/2" Lock Washer	1
	50721	1/2" Uss Flat Washer	1
118	10191	Key stock – 3/16"	1
119	18061	Tension Mount Engine, 265 - Black	1
-	50157	5/16x 3/4" Bolt Hex Hd NF	2
-	50703	5/16" Lock Washer	2
-	50704	5/16" Flatwasher	2

Reference Number	Part Number	Part Description - 265cc 2WD Models	Quantity Required
120	70250	Rubber Feet (Isolators)	5
-	50010	3/8 Nylock Nut	10
-	50740	3/8 Flatwasher USS	5
121	10581	Rod End Sphcl-UTV (4681-MPM-12)	3
122	50021	3/4 Jam nut SAE	3
123	45403	Panhard bar, CW - black	1
124	50206	bolt, 3/8 x 1	4
-	50010	3/8" Nylock Nut	4
-	50740	3/8" Flatwasher, USS	4
125	50730	3/4" Spacer Washer	6
126	50280	3/4 x 2.5 SAE bolt	3
127	50020	3/4 SAE nylock	3
128	18011	Shifter cable mount	
129	18012	shifter cable lever,	1
-	50084	1/4-20 x 3/4" Hex Hd Bolt	1
-	50000	1/4" Keps Nut	1
-	50715	1/4" Flatwasher, USS	2
130	11103	Brake Cables	2
-	50150	5/16-18 x 1" Hex Hd Bolt	2
-	50007	5/16" Nylock Nut	2
131	11013	Throttle Cable, 265	1
135	11082	Cable, shifter	2
138	18313	Belt Guard Plastic UTV - Front	1
139	18314	Belt Guard Plastic UTV - Rear	1
140	18315	Belt Guard Plastic UTV - Bottom	1
-	50624	#10 x 3/4" Blunt Point Black	7
-	50050	#10 Speed Nut - for Plastic	7
-	50770	#10 Flat washer	7

340cc
CW11/ TW11/ TW11R
Utility Vehicle
Parts Breakdown

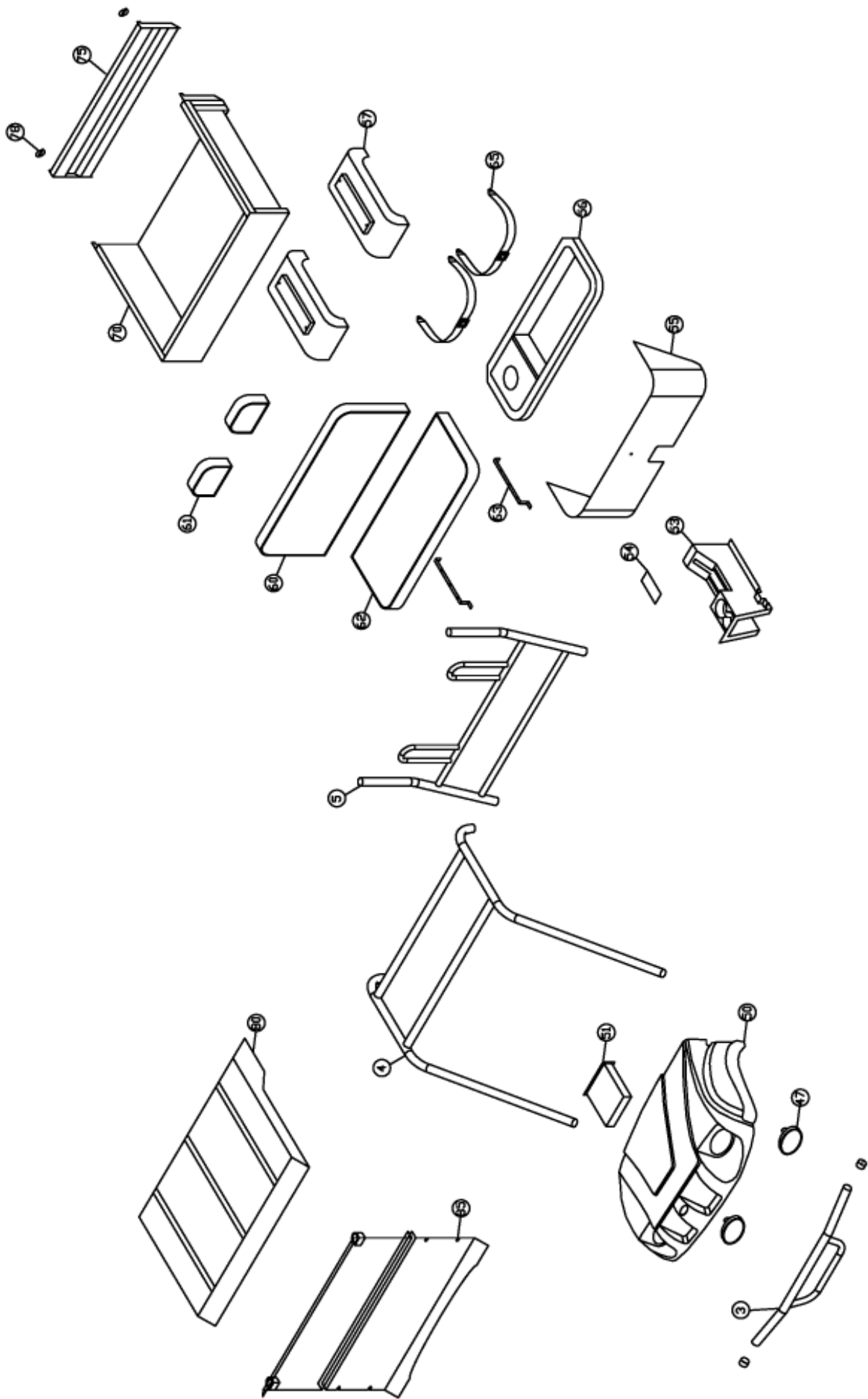

Body
340cc Models

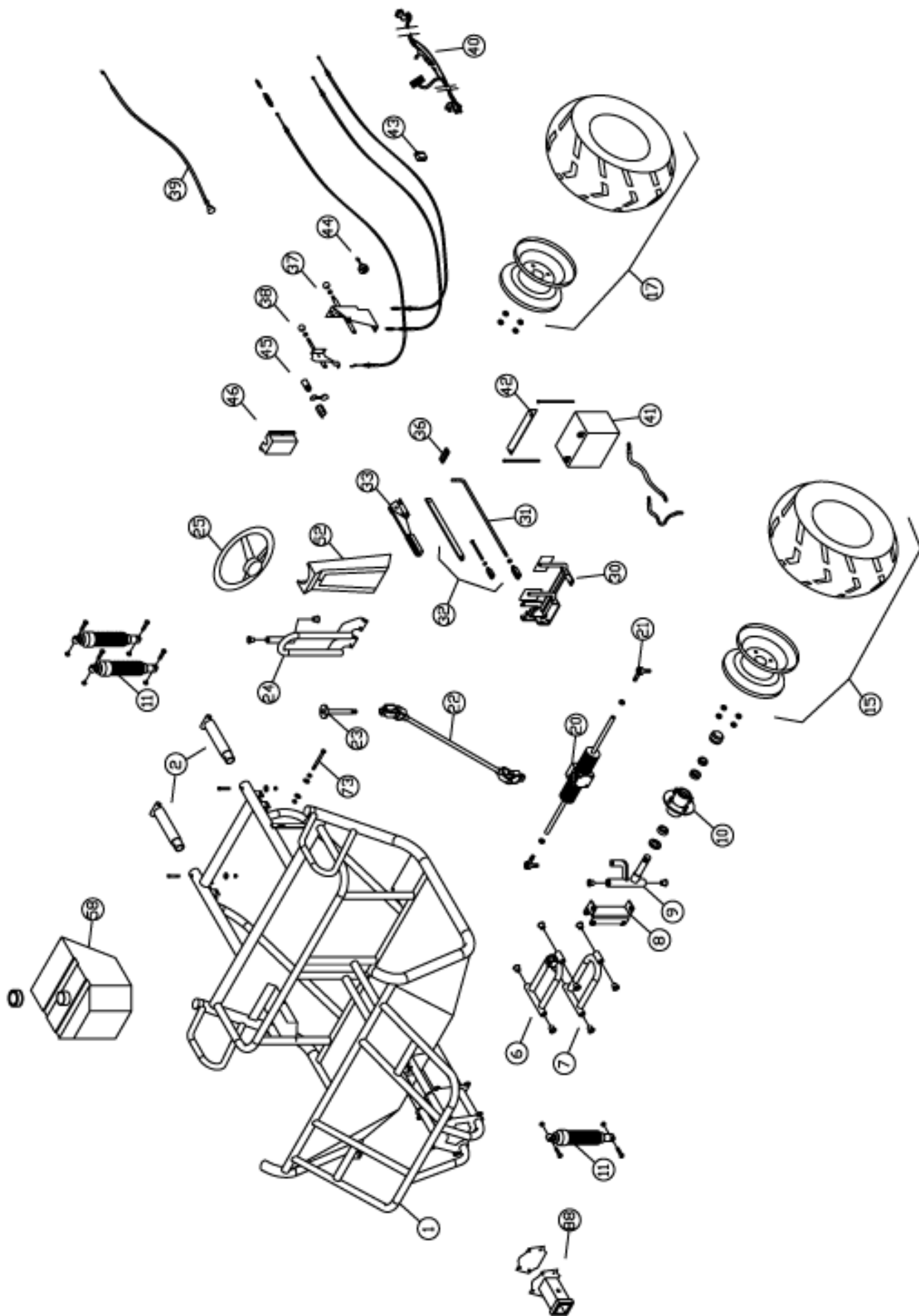

Frame
340cc Models

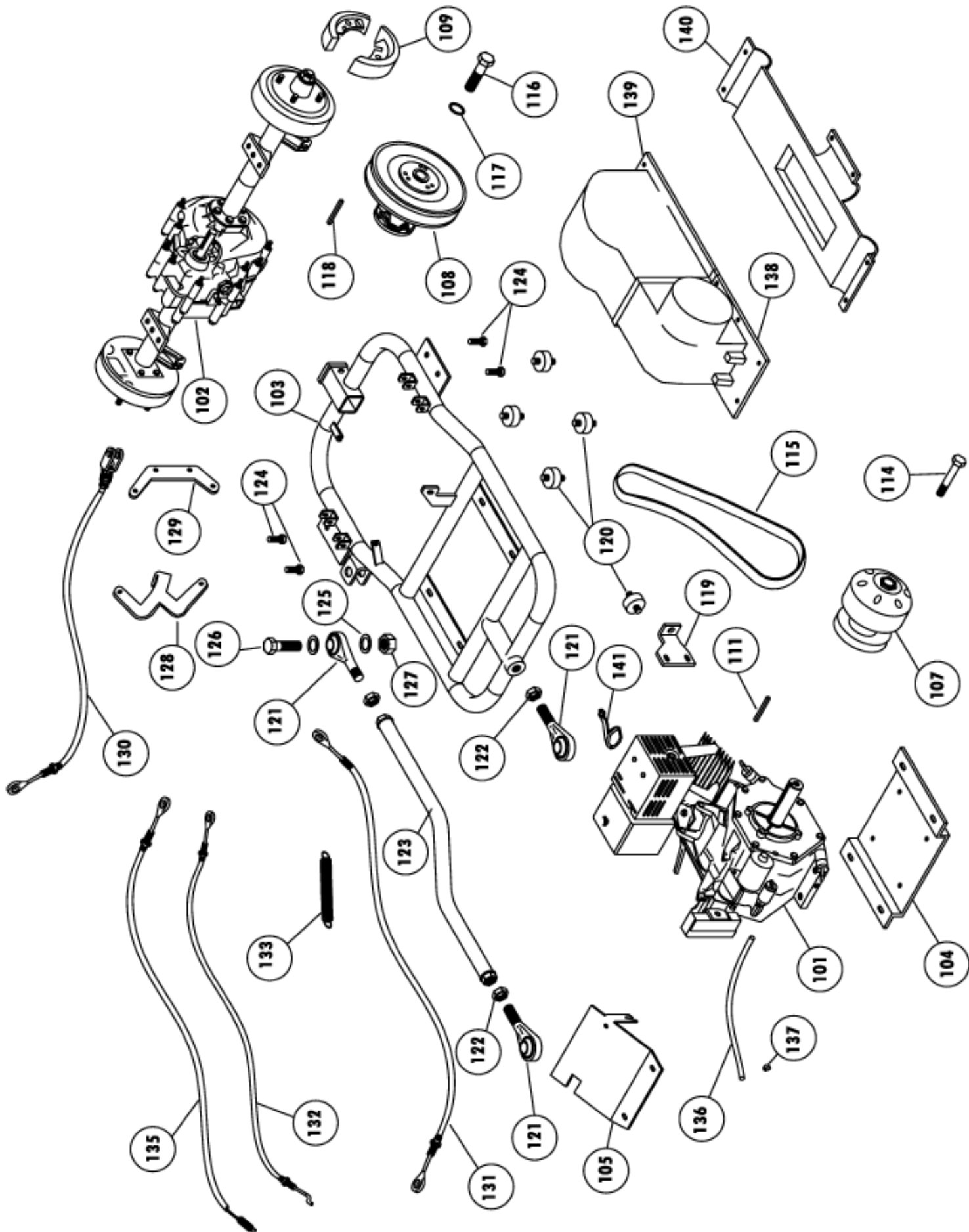

Drive Train
340cc Models

Reference Number	Part Number	Part Description - 2WD Models	Quantity Required
1	45419	Frame, CW11	1
2	45401	Rear frame stub, CW - black	2
	50168	5/16 x 2-1/4" USS Socket Head bolt	2
	50007	nut, 5/16 nylock	2
	50702	bent washer 5/16	2
3	45413	bumper, CW - black	1
	45432	Bumper, Trail Wagon – Black	1
	50167	bolt, 5/16 x 2	4
	50007	nut, 5/16 nylock	4
	50702	bent washer 5/16	4
	70208	Vinyl Caps 1 3/4 x 1 1/2	2
4	45412	Brush Guard roof, CW – black	1
	50168	5/16 x 2-1/4" USS Socket Head bolt	4
	50007	nut, 5/16 nylock	4
	50702	bent washer 5/16	4
5	45411	brshgrd seat back, CW – black	1
	50168	5/16 x 2-1/4" USS Socket Head bolt	2
	50007	nut, 5/16 nylock	2
	50702	bent washer 5/16	2
6	45404	A-arm upper, CW – black (left or right)	2
	51100	suspension bushings	4 ea
	50262	bolt, 5/8 x 9"	1 ea
	50254	Bolt, 5/8 x 3.5 bolt	1 ea
	50015	Nut, 5/8 nylock	2 ea
7	45405	A-arm Lower, CW – black (left or right)	2
	51100	suspension bushings	4 ea
	50262	bolt, 5/8 x 9"	1 ea
	50254	Bolt, 5/8 x 3.5 bolt	1 ea
	50015	Nut, 5/8 nylock	2 ea
8	45408	spindle mount, CW – black	2
9a	45406	Spindle, cw left – black	1
9b	45407	Spindle, cw right – black	1
	51100	suspension bushings	2 ea
	50262	bolt, 5/8 x 9"	1 ea
	50015	Nut, 5/8 nylock	1 ea
10	30604	Hub, 4 bolt high speed 1" Complete with Bearings & Seals	2
	11205	bearing, 1" tapered	
	30620	seal	
	30622	castle nut, 1"	
	30621	cotter pin	
	30623	dust cap	

Reference Number	Part Number	Part Description – 2WD Models	Quantity Required
	50060	Lug nuts, ½”	
11	70301	Shock, Heavy duty #1	6
	50400	Bolt, 10 mm x 40mm	12
	50065	Nut, 10mm nylock	12
15L	30122	Rim/Tire Assembly, UTV 22/9-10” Left	1
15R	30123	Rim/Tire Assembly, UTV 22/9-10” Right	1
	30480	Wheel rim, 10” x 6”	
	30195	Tire, Pathfinder 22/9-10”	
17L	30124	Rim/Tire Assembly, UTV 22/11-10” Left	1
17R	30125	Rim/Tire Assembly, UTV 22/11-10” Right	1
	30480	Wheel rim, 10” x 6”	
	30194	Tire, Pathfinder 22/11-10”	
20	10521	Rack & pinion with rod ends	1
	10593	Rack & Pinion Boots	2
	10590	Rack & Pinion Rod	2
	50171	Bolt, 5/16 x 3 ¾” USS	4
	50005	Nut, 5/16 keps	4
	50063	Nut, ½” SAE nylock	2
21	10524	Rod end “ use before serial #27214”	2
	10597	Rod end “ use after serial #27213”	2
	50078	Nut, ½” SAE jam	2
22	10522	Steering Shaft w/u-joints	1
	50402	Bolt, 10mm x 30mm	1
	50066	Nut, 10mm Tri Lock Jam	1
	50403	Bolt, 8mm x 30mm	1
	50780	Lock washer, 8mm	1
23	45422	Steering Stub Shaft Assembly, CW – Black	1
24	45400	Steering support, CW – black	1
	51100	suspension bushings	2 ea
	50152	bolt, 5/16 x 1	4
	50005	Nut, 5/16 keps	4
25	10502	Steering Wheel 13”	1
	10506	Center cap	
		screw, included with center cap	
	50081	bolt, ¼ x 1 ¾	3
	50001	nut, ¼ nylock	3
30	45402	Pedal assembly, CW – black	1
	50152	bolt, 5/16 x 1	6
	50081	bolt, ¼ x 1 ¾”	1
	50159	bolt, 5/16 x 1 ½	1
	50005	Nut, 5/16 keps	8
	50701	Washer, 5/16 flat	2

Reference Number	Part Number	Part Description – 2WD Models	Quantity Required
31	11181	Brake Rod, with clevis	1
	50215	bolt, 3/8 x 1 1/4	1
	50010	nut, 3/8" nylock	1
	50801	cotter pin 1/8" x 1	1
32	45417	parking brake bar, CW – black	1
	50806	Clevis, 5/16 rod end	1
	50170	Bolt, 5/16"-24 X 4" SAE	1
	50077	Nut, 5/16" Hex SAE	1
	50087	bolt, 1/4" x 1	1
	50001	nut, 1/4" nylock	1
33	11127	Parking Brake	1
	50086	Bolt, 1/4 x 1 1/4	1
	50001	nut, 1/4" nylock	1
	50163	bolt, 5/16 x 3/4" NC	4
	50005	Nut, 5/16 keps	4
	50701	Washer, 5/16 flat	4
36	45415	Brake equalizer, CW (2 1/2") – black	1
	50215	bolt, 3/8 x 1 1/4	2
	50010	nut, 3/8" ny-lock	2
37	11085	Shifter control assembly, black (built after 2-1-05)	1
	11083	Knob	1
	11082	Cable, shifter (built after 2-1-05)	2
	11080	Shifter Cable and Shifter Control (built before 2-1-05)	1
	50053	nut, #10-24 Keps nut	2
	50616	screw, #10-24 X 3/4" Pan Head Phillips	2
	50770	Washer, #10 flat	2
38	11086	Differential Control assembly with cable and knob	1
	11083	Knob	
	11090	Differential Control Handle –	1
	11091	cable, diff lock	
	50053	nut, #10-24 Keps nut	2
	50616	screw, #10-24 X 3/4" Pan Head phillips	2
	50770	Washer, #10 flat	2
40	70012	Wire Harness	1
41	70000	Battery, U1L-HDJ7-UTV - 360CCA	1
	70002	Battery Cable, Red – 17"	1
	70010	Battery Cable, Black (24")	1
	70009	Battery Terminal Cover	2
	50087	bolt, 1/4" x 1	2
	50000	nut, 1/4" keps	2

Reference Number	Part Number	Part Description – 2WD Models	Quantity Required
42	45414	Battery strap, CW (8 ¾") – black	1
	50083	bolt, ¼ x 7 ½	2
	50002	nut, ¼" wing	2
43	70055	Light Switch	1
44	70052	Key Switch	1
	70060	Key, 1 pair	
45	70080	Accessory Plug	1
	70081	Accessory Plug cap	1
46	18500	Terminal Block Cover – plastic	1
	50625	screw, #10-24 X 1" Pan Head Phillips	2
	50053	nut, #10-24 Keps nut	2
47	70129	Headlights	2
	70055	Switch Headlights	1
50	18311	Hood, plastic Green	1
	18302	Hood, plastic Red	
	18350	Hood, plastic Camo	
	50620	¼" X 1 ¼" Pan Head Phillips Machine screw	2
	50621	¼" X 2" Pan Head Phillips Machine screw	2
	50717	¼" SAE Flat washer	8
	50001	nut, ¼" nylock	4
	50846	Clamp-Tube-vinyl coated 1-1/4"	2
51	18309	Glove Box	1
	50624	Screw, #10 x ¾ hex – black	5
52	18308	Steering Cover	1
	18317	Steering Cover Bottom	1
	50624	Screw, #10 x ¾ hex – black	1
53	18306	Center Console	1
	50624	Screw, #10 x ¾ hex – black	14
54	18316	Access Cover, Center Console	1
	50624	Screw, #10 x ¾ hex – black	4
55	18305	Plastic, Seat Bottom wrap	1
	50624	Screw, #10 x ¾ hex – black	5
56	18304	Under seat storage box	1
57	18303	Rear Fender	1
	50001	nut, ¼ nylock	4
	50091	¼"-20 X ¾" Carriage bolt	4
	50717	¼" SAE Flat washer	4
	70150	Reflectors	2

Reference Number	Part Number	Part Description – 2WD Models	Quantity Required
58	55060	Fuel Tank	1
	55063	Elbow Fuel Inlet w/ #200 Mesh Screen	1
	55062	Fuel Fitting Grommet	1
	55061	Cap Fuel Tank	1
	50163	bolt, 5/16 x 3/4" NC	3
	50706	Washer, 5/16 fender	3
	50703	Washer, 5/16 lock	3
60	10754	Seatback 43 ½ x 17 ½	1
	50619	#14 X 1-3/4" Pan head-Tapping screw	6
61	10803	Headrest – UTV 9 x 6 ½	2
	50085	bolt, ¼ x 1 ½"	4
62	10755	Seat bottom 43 ½ x 17 ½	1
63	45416	seat bar, CW (17 ½") – black	2
	50609	#14 x ¾ Pan Head Screw	6
65	10705	Seat Belt, 2pt	2
	50025	7/16 Nylock	4
70	45426	Cargo Bed, Green	1
	45420	Cargo Bed, Red	1
	45424	Cargo Bed, Black	1
	18352	Camo Bed Panel Left	1
	18353	Camo Bed Panel Right	1
	18354	Camo Bed Panel Tail Gate	1
	50255	5/8 x 4" bolt Zinc plate	2
	50015	5/8 nylock	2
	18402	Bed Rubber Plug	2
73	50208	Bed latch bolt, 3/8 x 2 1/2"	1
	50013	nut, 3/8 keps	2
	50740	washer, 3/8 flat	2
75	45427	Tail gate, green	1
	45421	Tail gate, Red	1
	45425	Tail gate, Black	1
	50152	bolt, 5/16 x 1	2
	50701	washer, 5/16 sae	4
	50007	nut, 5/16 nylock	2
	70230	rubber bump stops	4
78	50815	1/4" Lynch Pin - tailgate latch	2

Reference Number	Part Number	Part Description - 2WD Models	Quantity Required
80	18312	Roof, green	1
	18301	Roof, Red	1
	18351	Roof, Camo	1
	18391	Roof, Top Vinyl Trim	1
	18390	Roof, Hardware bolt kit	
	50847	Clamp-Tube-vinyl coated 1-3/4"	4
	50087	bolt, 1/4" x 1	4
	50718	Washer, 1/4" rubber domed	4
	50001	nut, 1/4" nylock	4
85	18400	Windshield - clear	
	18401	Windshield - tinted	
	18403	Fastener kit, windshield	
88	40723	Front receiver hitch kit	
101	20010	Engine, Honda 11hp	1
-	50202	3/8-16 x 1 3/4" Hex Hd Bolt	4
-	50740	3/8" Flat washer, USS	4
102	20833	Dana Transaxle	1
	70057	Neutral Safety Switch	1
	51500	Shims – Neutral Safety Switch	
103	45423	Swing arm, CW - Black	1
104	45430	Motor Plate, CW - Black	1
105	18023	Throttle Guard Laser	1
-	50086	1/4-20 x 1 1/4" Hex Hd Bolt	3
-	50082	1/4-20 x 2 1/4" Hex Hd Bolt	1
-	50000	1/4" Keps Nut	5
-	50715	1/4" Flatwasher, USS	8
107	20648	TC, Driver Comet 500 – used before Serial Number # 25658	1
	20665	TC, Driver CVTECH – used after Serial Number # 25658	1
108	20649	TC, Driven Comet 500 – used before Serial Number # 25658	1
	20666	TC, Driven CVTECH – used after Serial Number # 25658	1
109	11171	Brake Shoes - Rear UTV – Dana "1 set for each wheel"	2
110	50745	1" I.D. Spacer Washer – Comet only (not used with CVTech pulley)	4
111	-	1/4" Key stock	1
112	-	3/8" I.D. Fender Washer – Comet only (not used with CVTech pulley)	1
113	50741	3/8" Lock Washer – Comet only (not used with CVTech pulley)	1
114	50219	3/8x 3" Bolt Hex Hd NF – Comet only (not used with CVTech pulley)	1
115	20693	Belt, Comet 300668 - used before Serial Number # 25658	1
	20694	Belt, CV TECH – used after Serial Number # 25658	1
116	50239	1/2 x 2" SAE	1

Reference Number	Part Number	Part Description - 2WD Models	Quantity Required
117	50722	1/2" Lock Washer	1
	50721	1/2" Uss Flat Washer	1
118	10186	Key stock – Special Key – 3/16" X 1/4" X 31/2"	1
119	45431	Tension Mount Engine, CW - Black	1
-	50157	5/16x 3/4" Bolt Hex Hd NF	2
-	50703	5/16" Lock Washer	2
-	50704	5/16" Flatwasher	2
120	70250	Rubber Feet (Isolators)	5
-	50010	3/8 Nylock Nut	10
-	50740	3/8 Flatwasher USS	5
121	10581	Rod End Sphcl-UTV (4681-MPM-12)	3
122	50021	3/4 Jam nut SAE	3
123	45403	Panhard bar, CW - black	1
124	50206	bolt, 3/8 x 1	4
-	50010	3/8" Nylock Nut	4
-	50740	3/8" Flatwasher, USS	4
125	50730	3/4" Spacer Washer	6
126	50280	3/4 x 2.5 SAE bolt	3
127	50020	3/4 SAE nylock	3
128	18012	shifter lever, CW - black - used before Serial Number #15244	1
-	50084	1/4-20 x 3/4" Hex Hd Bolt	1
-	50000	1/4" Keps Nut	2
129	18011	shifter cable mount, CW - black - used after Serial Number #15245	1
-	50084	1/4-20 x 3/4" Hex Hd Bolt	1
-	50000	1/4" Keps Nut	1
-	50715	1/4" Flatwasher, USS	2
130	11103	Brake Cables	2
-	50150	5/16-18 x 1" Hex Hd Bolt	2
-	50007	5/16" Nylock Nut	2
131	11010	Throttle Cable, UTV	1
-	50087	1/4-20 x 1" Hex Hd Bolt	1
-	50000	1/4" Keps Nut	2
-	11804	Spring #80704 Black painted	1
132	11084	Differential Cable All 2WD models before serial #22187	1
-	50087	1/4-20 x 1" Hex Hd Bolt	1
-	50000	1/4" Keps Nut	2
-	50159	5/16-18 x 1 1/2" Hex Hd Bolt	1
-	50005	5/16" Keps Nut	2

Reference Number	Part Number	Part Description - 2WD Models	Quantity Required
132	11086	Differential Control Assembly w/ cable all models after serial # 22187	1
-	11083	Knob	1
-	11091	Differential Control Cable Only used on all models after serial # 22187	1
-	50053	nut, #10-24 Keps nut	2
-	50616	screw, #10-24 X 3/4" Pan Head phillips	2
-	50770	Washer, #10 flat	2
-	50087	1/4-20 x 1" Hex Hd Bolt	1
-	50000	1/4" Keps Nut	2
-	50159	5/16-18 x 1 1/2" Hex Hd Bolt	1
-	50005	5/16" Keps Nut	2
133	11804	Spring #80704 Black painted	1
135	11080	Shifter Cable and Shifter Control - used before Serial Number #15244	1
	11082	Cable, shifter - used after Serial Number #15245	2
136	65500	fuel hose 3/16" dia - 24"	1
137	50849	hose clamps - small	3
138	18313	Belt Guard Plastic UTV - Front	1
139	18314	Belt Guard Plastic UTV - Rear	1
140	18315	Belt Guard Plastic UTV - Bottom	1
-	50624	#10 x 3/4" Blunt Point Black	7
-	50050	#10 Speed Nut - for Plastic	7
-	50770	#10 Flat washer	7
141	20011	Choke Bracket Honda Engine	1

4 Wheel Drive Dana & Hilliard Transaxle Parts Breakdown

Gen III Front Drive System Differential Gearcase P/N 6203-01-256

Parts and Service Manual

Rev. 0 Released 11/12/2007

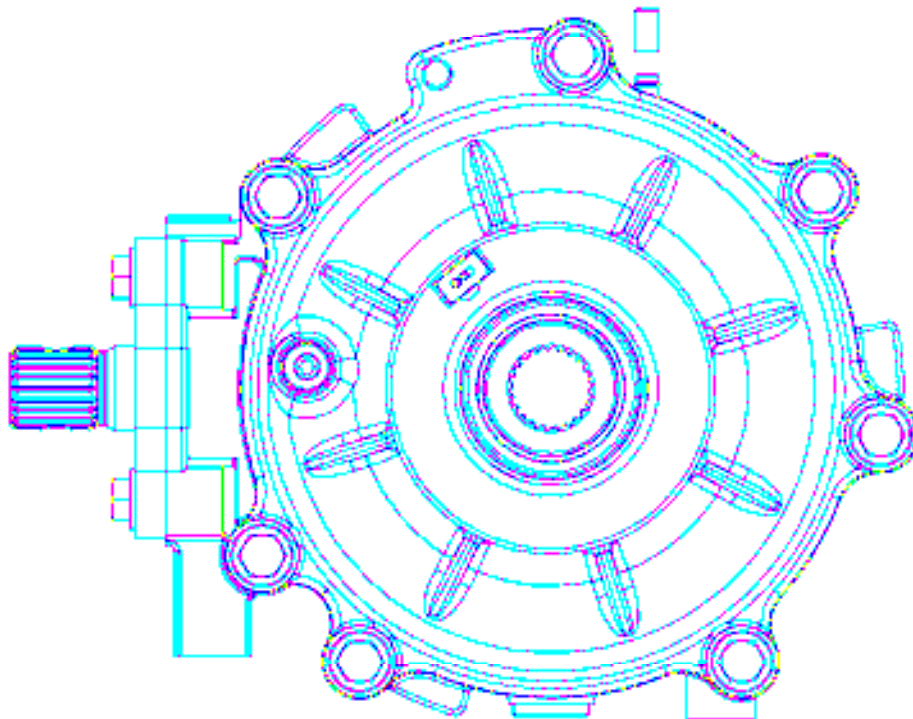

Basic Operation:

The Hilliard Front Drive System (Differential) is an electro-mechanically-activated bi-directional overrunning clutch. When 12 volts of power is sent to the 4WD switch, the unit is activated to engage both front wheels instantaneously, whenever the rear wheels lose traction. The clutch also releases or overruns automatically the instant the rear wheels regain traction. Because torque is transmitted to both front wheels, it is a “true” 4WD. The over-running characteristics of this system allow for an on demand 4WD engagement and steering ease.

Specifications:

Ratio.....	3.82:1 (Input:Output)
Fluid Capacity.....	150ml. (5 oz.) Hilliard CFD Gearcase Lube
Voltage.....	12 volts (15 volts max/11 volts min)
Coil Resistance.....	24.7 ohms to 27.3 ohms (at 20°C/68°F)
Input & Output Cover Bolt Torque.....	17 ft*lbs
Mounting Bolt Torque.....	32 ft*lbs.
Oil Fill Plug Torque.....	10 ft*lbs
Oil Drain Plug Torque.....	10 ft*lbs
External Input Shaft Spline.....	22 Tooth, 24/48 Pitch, Fillet Root Side Fit, Special Class 7
Internal Output Shaft Spline.....	22 Tooth, 24/48 Pitch, Fillet Root Side Fit, Special Class 7
Mounting Feet Thread Size.....	3/8-16 UNC-2B, (4) Places x .85” Deep
Continuous Torque Rating.....	145 ft*lbs (Input)
Hilliard 4WD CFD Gearcase Oil Part Number.....	0756-01-015-T

General Maintenance:

It is recommended that the oil be changed once every 2000 miles. To change the oil, follow each step on the procedure listed below.

Oil Change Procedure

1. Remove the oil drain plug located on the bottom of the gearcase using a 5/16” hex key wrench.
2. Let all the oil drain out of the unit. Catch and discard the oil properly.
3. Be sure to clean off any debris on the drain plug and reinstall. Torque the oil drain plug to 10 ft*lbs.
4. Remove the oil fill plug using a 5/16” hex key wrench.
5. Add 150 ml. (5 oz.) of the Hilliard CFD Gearcase Lube (*note: do not use any other type of oil in this system or the 4WD will not operate properly!*)
6. Reassemble the oil fill plug into the gearcase and torque to 10 ft*lbs.

Backlash Adjustment

1. Using a 5/32” Allen wrench, turn the #10-24 socket head cap screw (located inside the hollowed out round boss protruding from the output cover) clockwise until it will not move any more (do not apply a lot of torque). At this point, you should not be able to turn the pinion gear (part #36). Do not tighten the screw.
2. Now, slowly turn the backlash cap screw counter-clockwise while turning the pinion gear at the same time. Keep slowly turning the backlash cap screw until the pinion gear can rotate (4) times (1 revolution of the ring gear) freely without any tight spots. You should only have to turn the backlash cap screw between ¼ and ½ of a turn to have the proper backlash set.

Troubleshooting:

Problem: 4WD will not engage

1. Check the minimum battery voltage going to the CFD Gearcase. The voltage should not read below 11 volts for the unit to operate properly. If the voltage is at or above 11 volts, continue on to step #2.
2. Check the resistance of the coil harness on the large output cover. This can be achieved by attaching a multi-meter to the (2) terminal pins (part #23) on the exploded view drawing located on page #5). The resistance should be 24.7 to 27.3 ohms (at 20°C/68°F). If the unit does not read any resistance, then there is a short in the coil & wire harness. The large Output Cover Sub-Assembly (P/N 6203-12-100) needs to be replaced. If the resistance in the coil is satisfactory, continue on to step # 3.
3. Check the armature plate (part #19) for a consistent wear pattern. To do this, completely drain the oil from the unit by removing the drain plug (part #32) located on the bottom of the gearcase with a 5/16" hex key wrench. Collect the oil and dispose properly. Remove the (7) hex head bolts (part #2) from the large cover using a 1/2" socket. Set the unit on a flat surface with the large output cover (part #27) facing up. Carefully lift the large cover straight up off of the gearcase. Remove the clutch housing/ring gear (part #12) out of the gearcase (be sure to hold the roll cage with the clutch housing/ring gear to prevent the cage from falling out). Remove the retaining ring (part #8) out of the large cover and then remove the nylon shim (part #40). Pick up the armature plate and wipe off any dirt or sludge. Inspect the surface that rides on the coil (part #26) located in the large output cover. There should be a consistent wear mark from the coil. Any interruptions in this wear pattern could indicate an out of flatness condition and the armature plate will need to be replaced (part #13). You can also check the flatness by setting the armature plate (tang facing up) on a flat surface or granite block and making sure the plate does not rock. If the armature plate wear is consistent and the plate is flat, continue on to step #4.
4. Check for the proper coil depth. The electro-magnetic coil (part #26) should set below the pole faces of the metal insert (steel u-shape piece pressed into the large cover assembly) located in the large output cover (part #27). To check this, simply run your fingers around the pole faces and make sure that the coil is correctly set below the metal insert along the entire circumference. If you feel the coil above the pole faces, replace the large output cover (P/N 6203-12-100). If the coil is fully below the pole faces, continue on to step #5.
5. Clean and inspect the internal clutch components. Slowly remove the roll cage (part #39) from the clutch housing/ring gear (part #12). Using a clean, dry, lint-free cloth, clean the (14) clutch rollers (part #38), the (2) race/output hubs (parts #16 & #17) and the internal profile in the clutch housing/ring gear (part #12). If there are any excessive scratches, nicks or deep flats present on any of these parts, replace with the proper service kit listed at the bottom of page 4.

Problem: 4WD will not disengage

1. Check the armature plate (part # 19) for a consistent wear pattern and flatness. To do this, completely drain the oil from the unit by removing the drain plug (part #32) located on the bottom of the gearcase with a 5/16" hex key wrench. Collect the oil and dispose properly. Remove the (7) hex head bolts (part #2) from the large cover using a 1/2" socket. Set the unit on a flat surface with the large output cover (part #27) facing up. Carefully lift the large cover straight up off of the gearcase. Remove the clutch housing/ring gear (part # 12) out of the gearcase (be sure to hold the roll cage with the clutch housing/ring gear to prevent the cage from falling out). Remove the retaining ring (part #8) out of the large cover and then remove the nylon shim (part # 40). Pick up the armature plate and wipe off any dirt or sludge. Inspect the surface that rides on the coil located in the large output cover. There should be a consistent wear mark from the coil. Any interruptions in this wear pattern could indicate an out of flatness condition and the armature plate will need to be replaced (part #19). You can also check the flatness by setting the armature plate (tang facing up) on a flat surface or granite block and making sure the plate does not rock. If the armature plate wear is consistent and the plate is flat, continue on to step #2.

2. Clean and inspect the internal clutch components. Slowly remove the roll cage (part # 39) from the clutch housing/ring gear (part #12). Using a clean, dry, lint-free cloth, clean the (14) clutch rollers (part #38), the (2) race/output hubs (parts #16 & #17) and the internal profile in the clutch housing/ring gear (part #12). If there are any excessive scratches, nicks or deep flats present on any of these parts replace with the proper service kit listed at the bottom of this page.
3. With the roll cage out of the Clutch Housing/Ring Gear (#12) inspect the (14) H-Clip Springs (part #30) and make sure all the springs are intact and none are broken. If any of the springs are broken, replace the roll cage assembly with the proper service kit listed at the bottom of this page.

Problem: Gear set is too loud

1. Refer to the "Backlash Adjustment" section located on the bottom of page 2.

Assembly Procedure:

To Reassemble the Gearcase, follow the procedure listed below:

1. Be sure that all parts are clean and free of any dirt or debris and all residual oil has been removed.
2. Check the condition of the square sectioned o-ring located on the large output cover (part #7). Make sure that it is clean and free of any cuts or nicks. It is recommended that this part is replaced whenever the unit is taken apart.
3. Place the thrust button (part # 41) back into the 1/2" hole located on the protruding boss on large cover plate (part #27). Place the thrust plate (part #13) on top of the same boss.
4. Press the race/output hub with the 1/2" male dowel pin (part #17) back into the large cover (part #27).
5. Set the armature plate (part #19) back onto the coil (part #25) located in the large cover plate (part #27). The tangs of the armature plate should face out from the cover.
6. Place the nylatron (plastic) shim plate (part #40) on top of the armature plate and install the retaining ring (part #8) back into the slot located on the large cover (part #27).
7. Insert the small needle roller bearing (part #6) onto the 1/2" dowel on the race/output hub.
8. Reassemble the clutch housing/ring gear (Part #12), the roll cage (part #39) and the (14) rollers (part #38).
9. Insert the assembled clutch from step #8 onto the large cover plate being sure to line up and insert the tangs from the armature plate (#19) into the mating slots on the roll cage (part #39). *It is very important to make sure the tangs on the armature plate are properly aligned into the slots on the roll cage or you will damage the armature plate and the 4WD will not work!*
10. Press the race/output hub with the 1/2" bushing (part #16) into the gearcase (part # 28).
11. Insert the gearcase (part #28) back onto the large cover plate assembly. Be sure the bolt holes are lined up and the pinion gear (part #36) and the clutch housing/ring gear (part #12) mesh properly.
12. Torque the (7) 5/16-18 UNC-2A x 1" long hex head bolts (part #2) to 17 ft*lbs.
13. Be sure to clean off any dirt or debris on the drain plug (part #32). Using a 3/16" hex key wrench, reassemble the plug into the bottom of the gearcase torque to 10 ft*lbs.
14. Remove the oil fill plug (part #37) and fill the unit with 150 ml. (5 oz.) of the Hilliard 4WD CFD Gearcase oil.
15. Reassemble the oil fill plug (part #37) into the gearcase assembly (part #28) and torque to 10 ft*lbs.
16. Follow the "Backlash Adjustment" procedure located on the bottom of page 2 and set the backlash.

Clutch Repair Kits Available for Standard Clutch Repair:

Roll Kit.....	P/N 6203-29-010-0
Race/Output Hub Assembly.....	P/N 6203-27-017-0
Clutch Housing/Ring Gear (Machined).....	P/N 6203-13-259
Clutch Assembly.....	P/N 6203-01-218
Roll Cage Assembly.....	P/N 6203-20-098

Note: A list of all available service kits and components can be found on the exploded view drawing on page #5.

Hilliard Drive Train Products Approved Lubricants list

- Mobilfluid 424
- Mobilfluid LT
- Hytran Ultra
 - Hytran
 - HyGuard
- Low Viscosity HyGuard
 - John Deere J20C
 - John Deere J20D
 - Texaco Rando HD 46
- Texaco TDH or TDH SS
 - Chevron 1000 THF
 - Shell Donax TD



SPICER OUTDOOR POWER EQUIPMENT COMPONENTS DIVISION

DANA CORPORATION

FREDERICKTOWN, OH 43019

SERVICE PARTS REPLACEMENT LISTING

MODEL NO.: 012AJ399-1

DATE ISSUED: 1/25/2005

DESCRIPTION: Axle Assembly, Rear (FNR W/ Diff Lock), W/Output Shaft

<u>Key No.</u>	<u>Dana Part No.</u>	<u>No. Req'd.</u>	<u>Description</u>
1	012CH345-X	1++	Housing, Axle (W/ Idler Shaft)
2	012CH317	1++	Housing, Axle, Finished
3	012LK133	1	Kit, Detent
4	012HH122	1	Seal, Oil
5	012GV164X	1	Assembly, Actuator
6	012SV118X	1	Assembly, Shift Rod
7	012HH128	3	Seal, Oil
8	012TA381-1X	1	Assembly, Tube
9	012TA380-1X	1	Assembly, Tube
10	070HM282	6	Screw, Flange Head
11	012HM130-1	8	Screw, Socket Head
12	840293	4	Ring, Retaining
13	012HD106	2	Bearing, Ball
14	500024-6	2	Pin, Cotter
15	012WD129-X	1	Assembly, Brake
16	012WD130-X	1	Assembly, Brake
17	34617	2	Seat, Spring
18	070HN218	8	Nut, Lock
19	012HN127	2	Nut, Hex Flange
20	012SR170-1	1	Shaft, Axle
21	012HM132-1	8	Bolt, Wheel
22	012WA123	2	Drum, Brake
23	012HU137X	2	Assembly, Hub, Wheel
24	012HM110-1	11	Screw, Flange Head
25	012HM110-2	2	Screw, Flange Head
26	012HN120	13	Nut, Lock
27	41356	1	Plug, Rubber
28	012HN140	1	Vent
29	012HP120	2	Pin, Dowel
30	585965	1*	Bearing, Ball
31	012GS307	1**	Shaft, Input
32	012LK134	1+	Kit, Shim
33	012HD111	1*	Bearing, Ball
34	012HD129	2*	Bearing, Ball
35	012HS121	2	Spacer, Flat
36	012HS126	1	Washer, Thrust

Please contact our Customer Service Department (866-646-5278)
To special order DANA Transaxle Parts

Key No.	Dana Part No.	No. Req'd.	Description
37	012HS125	1	Washer, Thrust
38	012GS202X	1**	Gear Assembly, Forward
39	012GS302	1	Gear, Clutch
40	012GS337	1	Shaft, Intermediate
41	012GS204X	1**	Gear Assembly, Reverse
42	012GS215	1**	Gear, Helical (Pinion)
43	012GS207X	1**	Gear Assembly, Idler
44	012HR128	1	Ring, Retaining
45	585994	1*	Bearing, Ball
46	012GS216	1**	Gear, Helical (Ring)
47	012KD129	1	Assembly, Differential
48	012HN138	4	Nut, Lock
49	012HM129	4	Bolt, Hex
50	026HS104	1	Gear, Clutch, Diff Lock
51	012CH319	1++	Housing, Diff Lock
52	3112	1	Seal, Oil
53	012SV117X	1	Assembly, Shift Shaft
54	314004	1	Lever, Actuating
55	4150221	1	Screw, Hex Head
56	4150223	1	Nut, Lock
57	012HD142	1*	Bearing, Ball
58	012SR171-1	1	Shaft, Axle
59	012HM137	6	Screw, Flange Head
60	5803	1	Switch
61	012HH140	1	Seal, Oil
62	026HP100	2	Bushing – Dowel
63	012HG145	1	Drain Plug

* - These Ball Bearings are available packaged together as a kit. Order Dana number 012KD124 for this kit.

** - The Internal Gears are available packaged together as a kit. Order Dana number 012KG106 for this kit.

+ - Use Shim(s) as required to maintain proper clearances.

++ - Sealant is to be applied between Left Hand and Right Hand Axle Housings. Sealant is to be applied between right hand axle housing and diff lock housing. Use Loctite Gasket Eliminator No. 518 or equivalent.

Please contact our Customer Service Department (866-646-5278)
To special order DANA Transaxle Parts

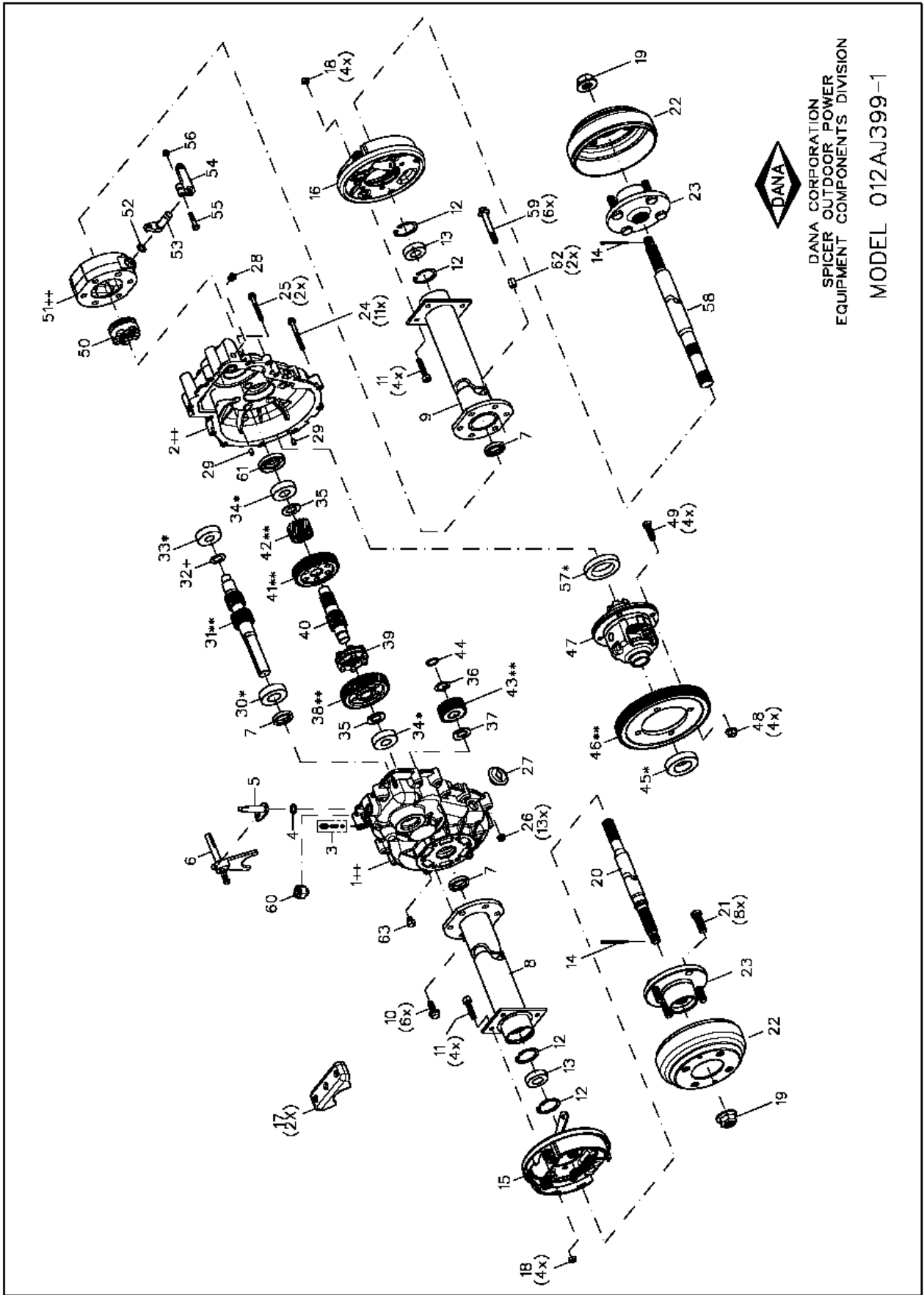

DANA CORPORATION
SPICER OUTDOOR POWER
EQUIPMENT COMPONENTS DIVISION

MODEL 012AJ399-1

**390cc
CW413 & TW413
4-wheel drive
Utility Vehicle
Parts Breakdown**

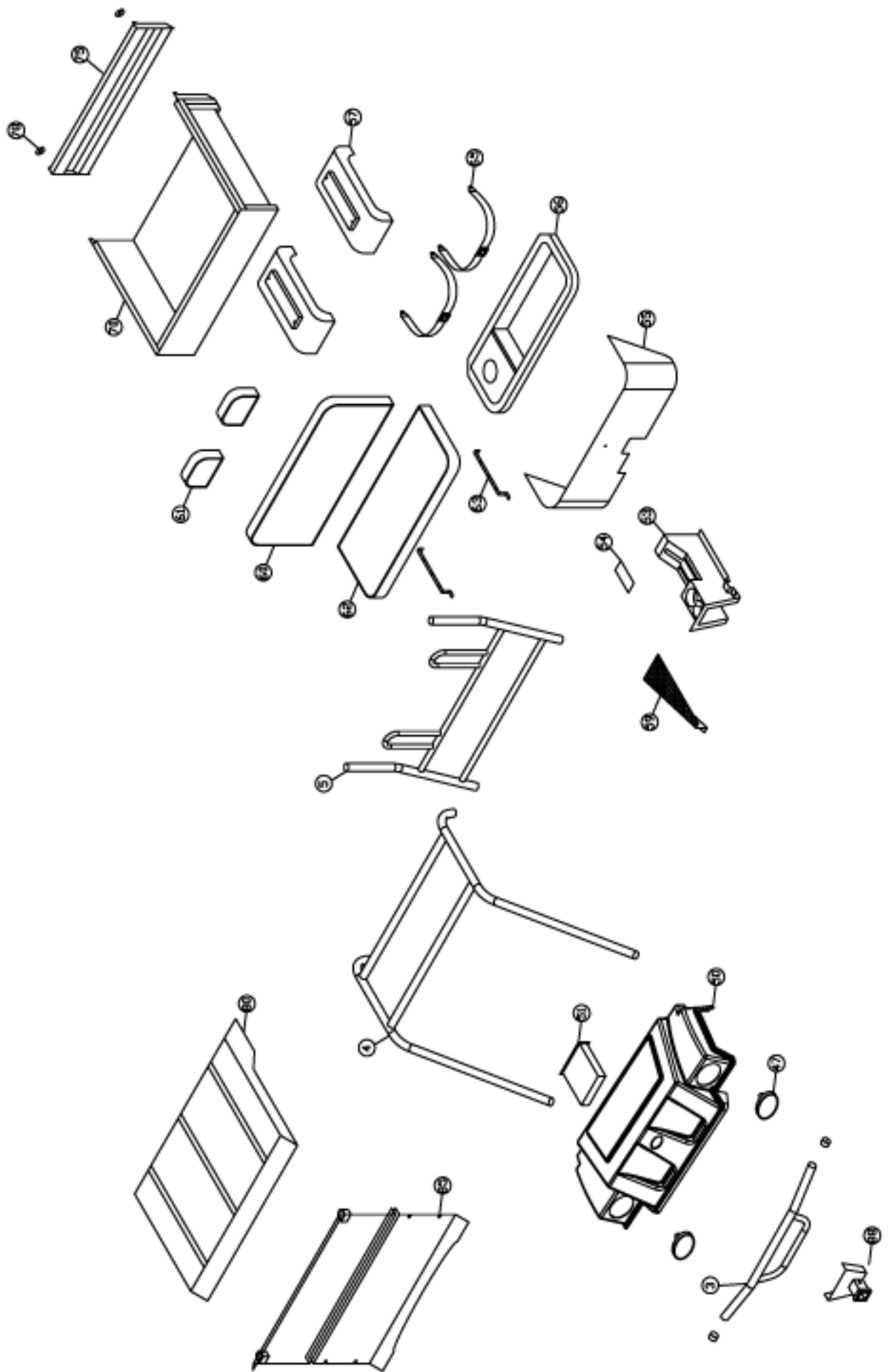

Body
390cc Models

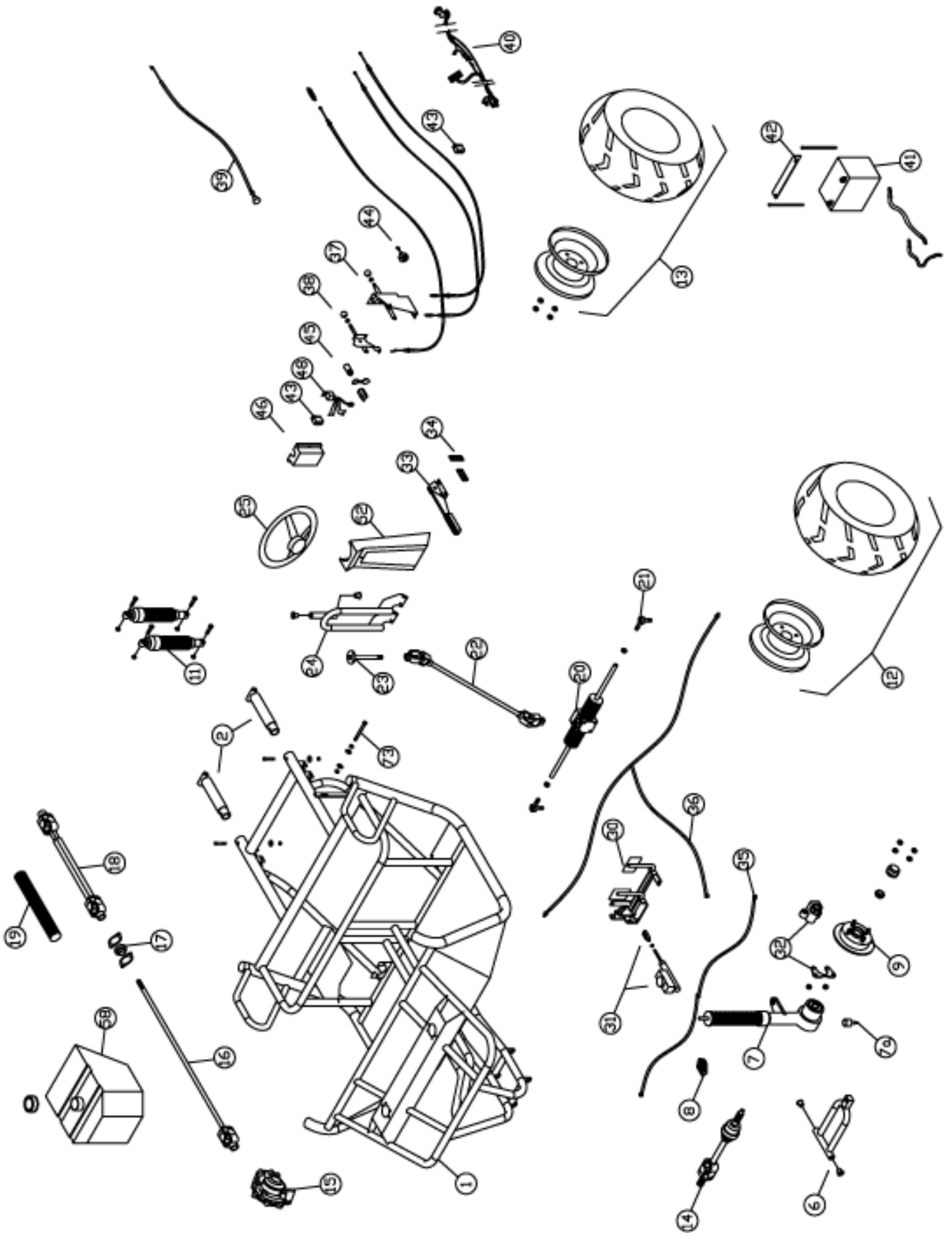

frame
390cc Models

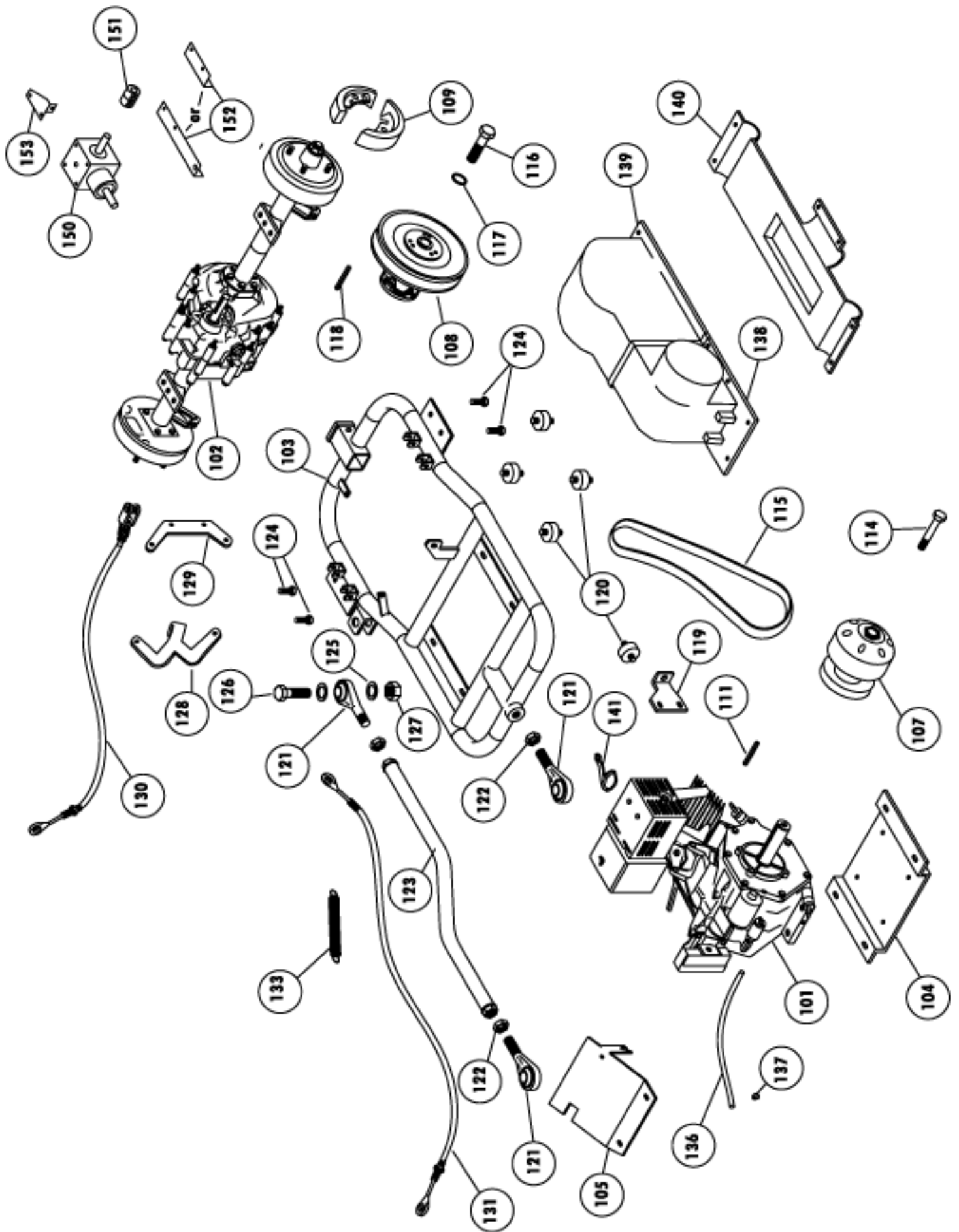

Drive Train
390cc Models

Reference Number	Part Number	Part Description – 4x4models	Quantity Required
1	45501	Frame, CW413 - 4x4	1
2	45401	Rear frame stub, CW - black	2
	50168	5/16 x 2-1/4" USS Socket Head bolt	2
	50007	nut, 5/16 nylock	2
	50702	bent washer 5/16	2
3	45413	Bumper, CW - black	1
	45433	Bumper, Trail Wagon – with grill guard - Black	
	50167	bolt, 5/16 x 2	4
	50007	nut, 5/16 nylock	4
	50702	bent washer 5/16	4
	70208	Vinyl Caps 1 3/4 x 1 1/2	2
4	45412	Brush guard roof, CW - black	1
	50168	5/16 x 2-1/4" USS Socket Head bolt	4
	50007	nut, 5/16 nylock	4
	50702	bent washer 5/16	4
5	45411	Brush guard seat back, CW - black	1
	50168	5/16 x 2-1/4" USS Socket Head bolt	2
	50007	nut, 5/16 nylock	2
	50702	bent washer 5/16	2
6	43007	A-arm 4x4, CW – black (left or right)	2
	51100	suspension bushings	2 ea
	50266	bolt, 5/8 x 9 1/2"	1 ea
	50015	Nut, 5/8 nylock	1 ea
	45150	Spacer/CW A-arm bushing-4x4	
7	25001	Strut assembly, left	1
	25009	Strut assembly, right	1
	50028	Nut, 7/16 NF jam	2
	50041	Nut, 3/8 NF slotted	2
	50801	cotter pin 1/8" x 1	2
7a	25020	Lower ball joint	2
8	25003	strut bearing	2
	50163	bolt, 5/16 x 3/4" NC	8
	50005	Nut, 5/16 keps	8
9	25002	Hub / rotor 4x4	2
	50040	Nut, 5/8 NF slotted	2
	30621	cotter pin	2
	30623	dust cap	2
	50060	Lug nuts, 1/2"	16
11	70301	Shock, Heavy duty #1	4
	50400	Bolt, 10 mm x 40mm	6
	50404	10 mm x 70mm bolt	2
	50065	Nut, 10mm nylock	8
	45150	spacer, shock	2
12L	30122	Rim/Tire Assembly, UTV 22/9-10" Left	1
12R	30123	Rim/Tire Assembly, UTV 22/9-10" Right	1
	30480	Wheel rim, 10" x 6"	
	30195	Tire, Pathfinder 22/9-10"	
13L	30124	Rim/Tire Assembly, UTV 22/11-10" Left	1
13R	30125	Rim/Tire Assembly, UTV 22/11-10" Right	1
	30480	Wheel rim, 10" x 6"	
	30194	Tire, Pathfinder 22/11-10"	

Reference Number	Part Number	Part Description – 4x4models	Quantity Required
14	20851	CV half shaft (axle) – (Left or Right)	2
	20868	Boot CV	
15	20839	front differential – 4x4	1
	20848	Hilliard Front Differential Replacement Oil “8oz bottle Mobile Fluid 424”	1
	50206	Bolt, 3/8 x 1	4
	50740	washer, 3/8 flat	4
	50741	washer, 3/8 lock	4
16	25006	drive shaft, front “used before serial #31586”	1
	25015	CV Front Drive Shaft “used after serial# 31586”	1
	50092	bolt, 1/4 x 2”	2
	50003	nut, 1/4 keps	2
17	25008	bearing, shaft support “used before serial #31586”	1
	25010	4x4, Drive shaft bearing-pillow block style – “used after serial # 31586”	1
	50163	bolt, 5/16 x 3/4” NC	2
	50005	Nut, 5/16 keps	2
18	25007	drive shaft, rear telescoping “used before serial #31586”	1
	25016	CV Rear Drive Shaft “used after serial# 31586”	1
	50631	Screw, 3/8” – 16 x 1/2” square head set	2
	10184	key, 3/16 x 1	3
19	20804	convoluted tubing	17 inch
20	10591	Rack & pinion with rod ends 4x4	1
	10593	Rack & Pinion Boots	2
	50171	Bolt, 5/16 x 3 3/4” USS	4
	50005	Nut, 5/16 keps	4
21	10594	Rod end 4x4 “used before serial # 27783”	2
	10598	Rod end 4x4 “used after serial # 27782”	2
	10595	Tie rod 4x4	2
	10593	Rack boot	2
22	10592	Steering Shaft w/u-joints 4x4	1
	50402	Bolt, 10mm x 30mm	1
	50066	Nut, 10mm Tri Lock Jam	1
	50403	Bolt, 8mm x 30mm	1
	50780	Lock washer, 8mm	1
23	45422	Steering Stub Shaft Assembly, CW - Black	1
24	45400	Steering support, CW - black	1
	51100	suspension bushings	2 ea
	50152	bolt, 5/16 x 1	4
	50005	Nut, 5/16 keps	4
25	10502	Steering Wheel 13”	1
	10506	Center cap	
		screw, included with center cap	
	50081	bolt, 1/4 x 1 3/4	3
	50001	nut, 1/4 nylock	3
30	45402	Pedal assembly, CW - black	1
	50152	bolt, 5/16 x 1	6
	50081	bolt, 1/4 x 1 3/4”	1
	50159	bolt, 5/16 x 1 1/2	1
	50005	Nut, 5/16 keps	8
	50701	Washer, 5/16 flat	2

Reference Number	Part Number	Part Description – 4x4models	Quantity Required
31	11123	master cylinder	1
	50167	bolt, 5/16 x 2	2
	50005	Nut, 5/16 keps	2
	50806	Clevis, 5/16 rod end	1
	50077	Nut, 5/16" Hex SAE	1
32	11124	brake caliper	2
	11167	brake pads (2 pads required per wheel)	4
	11168	brake pins	4
	11169	brake clips	4
	50826	Spacer Lock collar, 3/8	4
	50217	bolt, 3/8 x 1 1/2	4
	50013	nut, 3/8 keps	4
	18030	caliper bracket	2
33	11127	Parking Brake	1
	50086	Bolt, 1/4 x 1 1/4	1
	50001	nut, 1/4" nylock	1
	50163	bolt, 5/16 x 3/4" NC	4
	50005	Nut, 5/16 keps	4
	50701	Washer, 5/16 flat	4
34	18038	Brake spreader	2
	50152	bolt, 5/16 x 1	4
	50007	nut, 5/16 nylock	1
35	11135	Brake hose, front	1
36	11136	Brake hose, rear	1
37	11085	Shifter control assembly, black	1
	11083	Knob	1
	11082	Cable, shifter	2
	50053	nut, #10-24 Keps nut	2
	50616	screw, #10-24 X 3/4" Pan Head phillips	2
	50770	Washer, #10 flat	2
38	11086	Differential Control Assy - 4x4 Diff Control w/ cable	1
	11083	Knob	1
	11091	cable, diff lock	1
	50053	nut, #10-24 Keps nut	2
	50616	screw, #10-24 X 3/4" Pan Head phillips	2
	50770	Washer, #10 flat	2
	50087	1/4-20 x 1" Hex Hd Bolt	1
	50000	1/4" Keps Nut	2
	50159	5/16-18 x 1 1/2" Hex Hd Bolt	1
	50005	5/16" Keps Nut	2
40	70012	Wire Harness	1
41	70000	Battery, U1L-HDJ7-UTV - 360CCA	1
	70002	Battery Cable, Red - 17"	1
	70010	Battery Cable, Black (24")	1
	70009	Battery Terminal Cover	2
	50087	bolt, 1/4" x 1	2
	50000	nut, 1/4" keps	2
	50000	nut, 1/4" keps	2

Reference Number	Part Number	Part Description – 4x4models	Quantity Required
42	45414	Battery strap, CW (8 3/4") - black	1
	50083	bolt, 1/4 x 7 1/2	2
	50002	nut, 1/4" wing	2
43	70055	Light Switch / 4x4 switch	2
44	70052	Key Switch	1
	70060	Key, 1 pair	
45	70080	Accessory Plug	1
	70081	Accessory Plug cap	1
46	18500	Terminal Block Cover - plastic	1
	50625	screw, #10-24 X 1" Pan Head phillips	2
	50053	nut, #10-24 Keps nut	2
47	70129	Headlights	2
	70055	Switch Headlights	1
48	70019	Relay w/harness, 4x4	1
50	18380	Hood, plastic - 4x4 (green)	1
	18384	Hood, plastic - 4x4 (camo)	1
	18381	Hood, plastic - 4x4 (red)	1
	50620	1/4" X 1 1/4" Pan phillips Machine screw	2
	50621	1/4" X 2" Pan phillips Machine screw	2
	50717	1/4" SAE Flat washer	8
	50001	nut, 1/4" nylock	4
	50846	Clamp-Tube-vinyl coated 1-1/4"	2
51	18309	Glove Box	1
	50624	Screw, #10 x 3/4 hex - black	5
52	18308	Steering Cover	1
	50624	Screw, #10 x 3/4 hex - black	1
	18317	Steering Cover Bottom	1
53	18383	Center Console 4x4	1
	50624	Screw, #10 x 3/4 hex - black	14
54	18316	Access Cover, Center Console	1
	50624	Screw, #10 x 3/4 hex - black	4
55	18382	Plastic, Seat Bottom wrap 4x4	1
	50624	Screw, #10 x 3/4 hex - black	5
56	18304	Underseat storage box	1
57	18303	Rear Fender	1
	70150	Reflectors	2
	50091	1/4"-20 X 3/4" Carriage bolt	4
58	50717	1/4" SAE Flat washer	4
	55060	Fuel Tank	1
	55063	Elbow Fuel Inlet w/ #200 Mesh Screen	1
	55062	Fuel Fitting Grommet	1
	55061	Cap Fuel Tank	1
	50163	bolt, 5/16 x 3/4" NC	3
	50706	Washer, 5/16 fender	3
	50703	Washer, 5/16 lock	3
59	18033	Shaft guard	1
	50163	bolt, 5/16 x 3/4" NC	3
	50005	Nut, 5/16 keps	4
	50171	Bolt, 5/16 x 3 3/4" USS	1
	10001	tube, 1" 14ga	1

Reference Number	Part Number	Part Description – 4x4models	Quantity Required
60	10754	Seatback 43 1/2 x 17 1/2	1
	50619	#14 X 1-3/4" Pan head-Tapping screw	6
61	10803	Headrest - UTV 9 x 6 1/2	2
	50085	bolt, 1/4 x 1 1/2"	4
62	10755	Seat bottom 43 1/2 x 17 1/2	1
63	45416	seat bar, CW (17 1/2") - black	2
	50609	#14 x 3/4 pan head tapping	6
65	10705	Seat Belt, 2pt	2
	50025	7/16 Nylock	4
70	45426	Cargo Bed, Green	1
	45420	Cargo Bed, Red	1
	45424	Cargo Bed, Black	1
	18352	Camo Bed Panel Left	1
	18353	Camo Bed Panel Right	1
	18354	Camo Bed Panel Tail Gate	1
	50255	5/8 x 4" bolt Zinc plate	2
	50015	5/8 nylock	2
	18402	Bed Rubber Plug	2
73	50208	Bed latch bolt, 3/8 x 2 1/2"	1
	50013	nut, 3/8 keps	2
	50740	washer, 3/8 flat	2
75	45427	Tail gate, green	1
	45421	Tail gate, Red	1
	45425	Tail gate, Black	1
	50152	bolt, 5/16 x 1	2
	50701	washer, 5/16 sae	4
	50007	nut, 5/16 nylock	2
	70230	rubber bump stops	4
78	50815	1/4" Lynch Pin - tailgate latch	2
80	18312	Roof, green	1
	18301	Roof, Red	1
	18351	Roof, Camo	1
	18391	Roof, Top Vinyl Trim	1
	18390	Roof, Hardware bolt kit	
	50847	Clamp-Tube-vinyl coated 1-3/4"	4
	50087	bolt, 1/4" x 1	4
	50717	1/4" SAE Flat washer	4
	50001	nut, 1/4" nylock	4
	50718	Washer, 1/4" Rubber Domed	4
85	18400	Windshield - clear	
	18401	Windshield - tinted	
	18403	Fastener kit, windshield	
88	40729	Front receiver hitch 4x4 kit	1
	50162	Bolt, 5/16 x 1-3/8 - U	4
	50704	Washer, 5/16 Flat	8
	50007	Nut, 5/16 Nylock	8
101	20012	Engine, Honda 13hp	1
	50202	3/8-16 x 1 3/4" Hex Hd Bolt	4
	50740	3/8" Flatwasher, USS	4
102	20838	Dana Transaxle 4x4	1

Reference Number	Part Number	Part Description – 4x4models	Quantity Required
103	45502	Swing arm, CW - Black 4x4	1
104	45430	Motor Plate, CW - Black	1
105	18023	Throttle Guard Laser	1
	50086	1/4-20 x 1 1/4" Hex Hd Bolt	3
	50082	1/4-20 x 2 1/4" Hex Hd Bolt	1
	50000	1/4" Keps Nut	5
	50715	1/4" Flatwasher, USS	8
107	20648	TC, Driver Comet 500 – used before Serial Number #25663	1
	20665	TC, Driver CVTECH – used after Serial Number #25663	1
108	20649	TC, Driven Comet 500 – used before Serial Number #25663	1
	20666	TC, Driven CVTECH – used after Serial Number #25663	1
109	11171	Brake Shoes - Rear 4WD UTV – Dana (1 set per wheel)	2
110	50745	1" I.D. Spacer Washer– Comet only (not used with CV Tech pulley)	4
111	-	1/4 x 3/16" Keystock	1
112	50742	3/8" I.D. Fender Washer– Comet only (not used with CV Tech pulley)	1
113	50741	3/8" Lock Washer– Comet only (not used with CV Tech pulley)	1
114	50219	3/8x 3" Bolt Hex Hd NF– Comet only (not used with CV Tech pulley)	1
115	20693	Belt, Comet 300668 used before Serial Number # 25663	1
	20694	Belt, CV TECH – used after Serial Number # 25663	1
116	50239	1/2 x 2" SAE	1
117	50722	1/2" Lock Washer	1
	50721	1/2" Uss Flat Washer	1
118	10186	3/16" Key stock	1
119	45431	Tension Mount Engine, CW - Black	1
	50157	5/16x 3/4" Bolt Hex Hd NF	2
	50703	5/16" Lock Washer	2
	50704	5/16" Flatwasher	2
120	70250	Rubber Feet (Isolators)	5
	50010	3/8 Nylock Nut	10
	50740	3/8 Flatwasher USS	5
121	10581	Rod End Sphcl-UTV (4681-MPM-12)	3
122	50021	3/4 Jam nut SAE	3
123	42093	Panhard bar, CW - black 4x4	1
124	50206	bolt, 3/8 x 1	4
	50010	3/8" Nylock Nut	4
	50740	3/8" Flatwasher, USS	4
125	50730	3/4" Spacer Washer	6
126	50280	3/4 x 2.5 SAE bolt	3
127	50020	3/4 SAE nylock	3
128	18012	shifter lever, CW - black	1
	50084	1/4-20 x 3/4" Hex Hd Bolt	2
	50000	1/4" Keps Nut	4
129	18011	shifter cable mount, CW - black	1
130	11104	Parking Brake Cables 4x4	2
	50150	5/16-18 x 1" Hex Hd Bolt	2
	50007	5/16" Nylock Nut	2
131	11010	Throttle Cable, UTV	1
	50087	1/4-20 x 1" Hex Hd Bolt	1
	50000	1/4" Keps Nut	2
	11804	Spring #80704 Black painted	1

Reference Number	Part Number	Part Description – 4x4models	Quantity Required
133	11804	Spring #80704 Black painted	1
136	65500	fuel hose 3/16" dia - 24"	1
137	50849	hose clamps - small	3
138	18313	Belt Guard Plastic UTV - Front	1
139	18314	Belt Guard Plastic UTV - Rear	1
140	18315	Belt Guard Plastic UTV - Bottom	1
	50624	#10 x 3/4" Blunt Point Black	7
	50050	#10 Speed Nut - for Plastic	7
	50770	#10 Flatwasher	7
141	20011	Choke Bracket Honda Engine	1
150	25004	right angle gearbox	1
	10184	Key, 3/16 x 1	3
151	20852	gearbox coupling	1
152	18042	Gear box bracket "torque arm" (long) built before 10-06	1
	18083	Gear box bracket (short) built after 10-06	1
	70232	rubber washer - built before 10-06	2
	50163	bolt, 5/16 x 3/4" NC	4
	50701	Washer, 5/16 flat	6
	50703	Washer, 5/16 lock	2
	50005	Nut, 5/16 keps	2
	50303	Bolt 7/16 x 1 3/4" - built before 10-06	1
	50794	Washer, 7/16 flat - built before 10-06	2
	50028	Nut, 7/16 nylock - built before 10-06	1
153	18032	diff lock mount	1
	50163	bolt, 5/16 x 3/4" NC	2
	50701	Washer, 5/16 flat	2
	50703	Washer, 5/16 lock	2

653cc
CW650/ TW650/ BD700
4-wheel drive
Utility Vehicle
Parts Breakdown

All Vehicles Post
August 2009

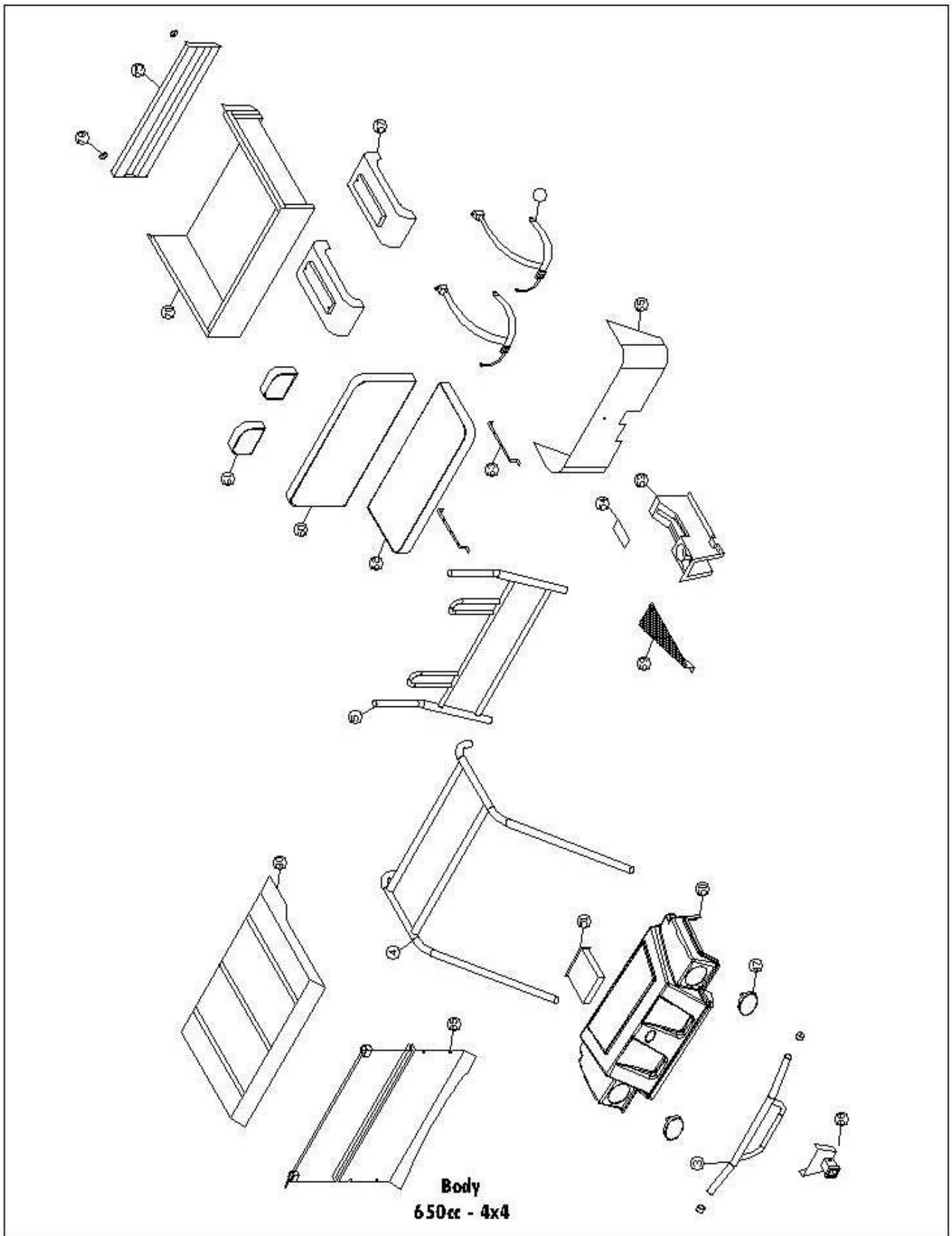

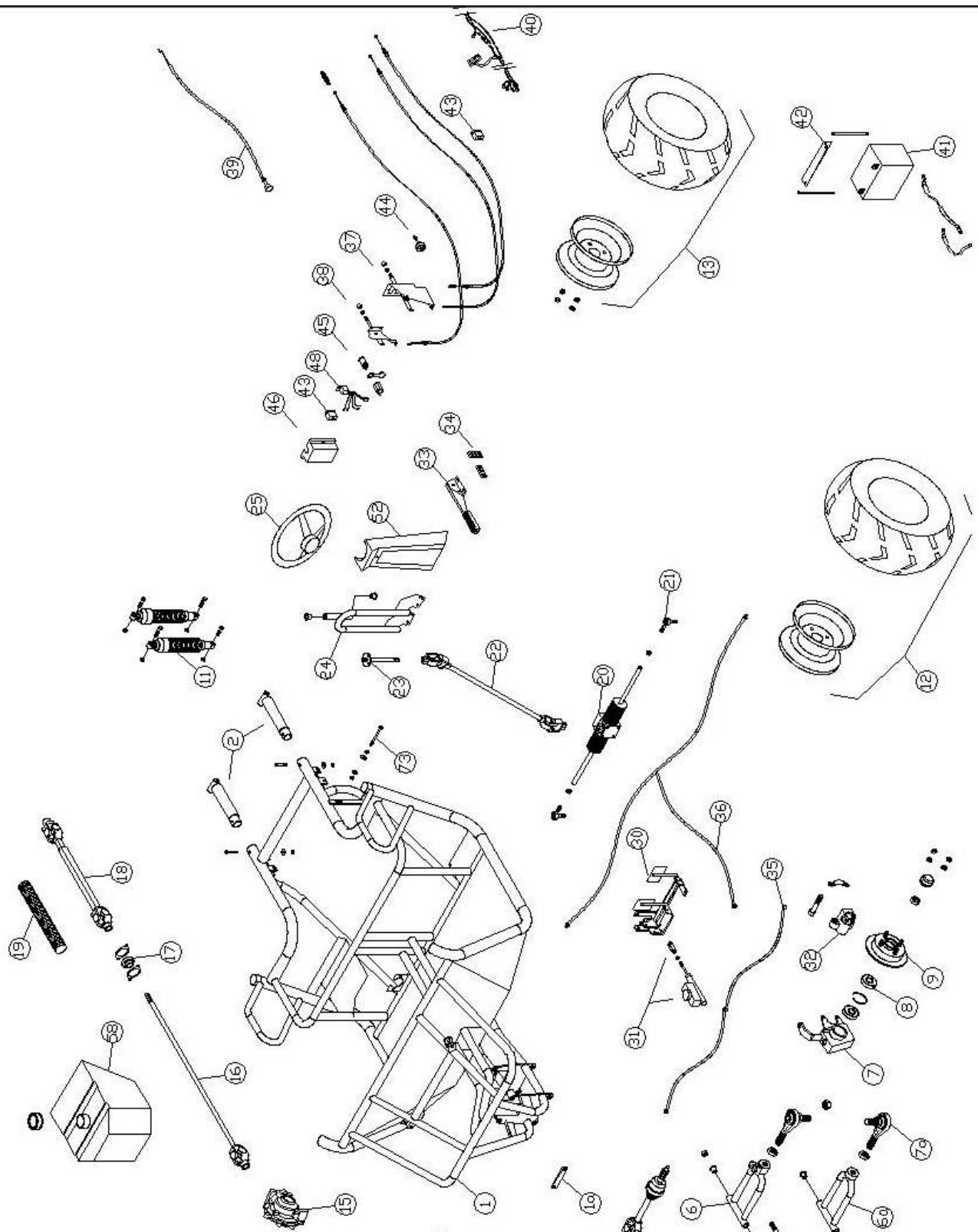

Frame
650cc - 4x4
Double A-Arm
Front Suspension

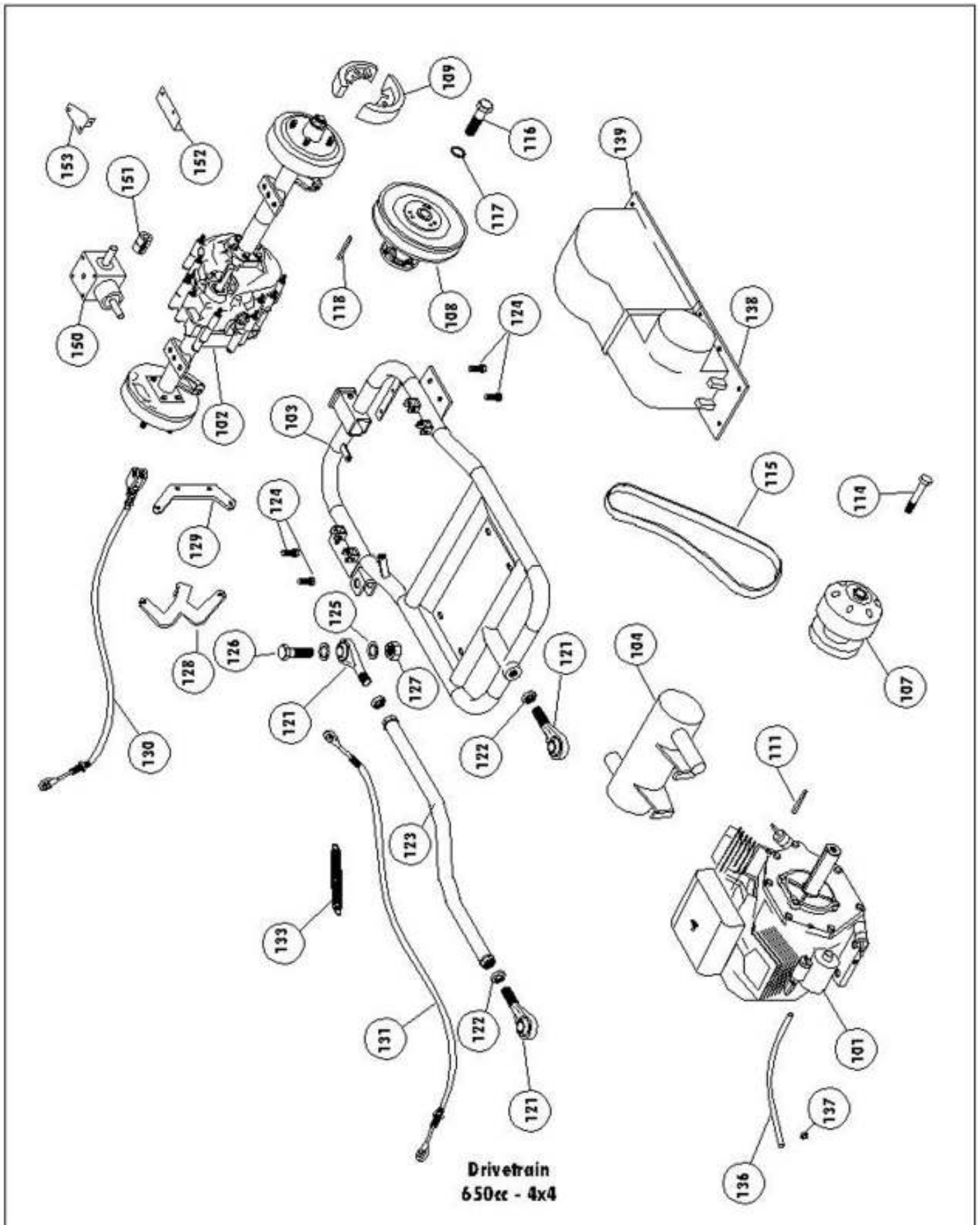

Models CW-650/TW-650/BD-700 Parts List (post August 2009)

<i>Reference Number</i>	<i>Part Number</i>	<i>Part Description 650cc Models</i>	<i>Quantity Required</i>
1		Frame, - CW650 4x4	1
1a	18112	Tie Bar (metal strip to connect A-arm mount front)	1
2	45401	Rear frame stub, CW - black	2
	50206	bolt, 3/8 x 1	8
	50013	nut, 3/8 keps	8
3	45413	bumper, CW - black	1
	50167	bolt, 5/16 x 2	4
	50007	nut, 5/16 nylock	4
	50702	bent washer 5/16	4
	70208	Vinyl Caps 1 3/4 x 1 1/2	2
4	45412	brshgrd roof, CW - black	1
	50168	5/16 x 2-1/4" USS Socket Head bolt	4
	50007	nut, 5/16 nylock	4
	50702	bent washer 5/16	4
5	45411	brshgrd seat back, CW - black	1
	50168	5/16 x 2-1/4" USS Socket Head bolt	2
	50007	nut, 5/16 nylock	2
	50702	bent washer 5/16	2
6	45445	A-arm, 4x4 Double A-arm Front UPPER- black	2
6a	45446	A-arm, 4x4 Double A-arm Front LOWER- black	2
	51100	suspension bushings	2 ea
	50225	bolt, 3/8 x 8"	1 ea
	50010	Nut, 3/8 nylock	1 ea
	42114	spacer, 3/8 ID 6.93" in length	1 ea
7	40554	Spindle Welded assembly, left	1
	40555	Spindle Welded assembly, right	1
7a	10598	Rod End (Heim Joint) 3/4" Studded	4
	50801	cotter pin 1/8" x 1	2
	25022	Snap Ring	2
8	25021	Front Spindle Bearing	4
	50021	Nut, 3/4 JAM	4
	50023	Nut, 3/4 Nylock	4
9	25014	Hub / 8" rotor 4x4	2
	50073	Nut, 5/8 Half Nylock	2
10	14535	Shock, Heavy Duty, Chrome/Yellow	2
	30623	dust cap	2
	50060	Lug nuts, 1/2"	16
11	70301	Shock, Rear, Black/Yellow	4
	50400	Bolt, 10 mm x 40mm	6
	50404	10 mm x 70mm bolt	2
	50065	Nut, 10mm nylock	8
	45150	spacer, shock	2
12L	30146	Rim/Tire Assembly, UTV 25/11-12" Left	1
12R	30147	Rim/Tire Assembly, UTV 25/11-12" Right	1
	30481	Wheel rim, 12"	
	30199	UTV 25/11-12 Tire only	

Reference Number	Part Number	Part Description 650cc Models	Quantity Required
13L	30146	Rim/Tire Assembly, UTV 25/11-12" Left	1
13R	30147	Rim/Tire Assembly, UTV 25/11-12" Right	1
	30481	Wheel rim, 12"	
	30199	UTV 25/11-12 Tire only	
14	20851	CV half shaft (axle)	2
15	20839	front differential - 4x4	1
	50206	Bolt, 3/8 x 1	4
	50740	washer, 3/8 flat	4
	50741	washer, 3/8 lock	4
16	25006	drive shaft, front	1
	50092	bolt, 1/4 x 2"	2
	50003	nut, 1/4 keps	2
17	25008	bearing, shaft support	1
	50163	bolt, 5/16 x 3/4" NC	2
	50005	Nut, 5/16 keps	2
18	25007	drive shaft, rear telescoping	1
	50628	Screw, 1/4-20 x 1/2" square head set	1
	10184	key, 3/16 x 1	3
19	20804	convoluted tubing	17 inch
20	10599	Rack & Pinion, 4x4 Double A-arm	1
	50171	Bolt, 5/16 x 3 3/4" USS	4
	50005	Nut, 5/16 keps	4
21	10594	Rod end 4x4	2
	10595	Tie rod 4x4	2
	10593	Rack boot	2
22	10592	Steering Shaft w/u-joints 4x4	1
	50402	Bolt, 10mm x 30mm	1
	50066	Nut, 10mm Tri Lock Jam	1
	50403	Bolt, 8mm x 30mm	1
	50780	Lock washer, 8mm	1
23	45422	Steering Stub Shaft Assembly, CW - Black	1
24	45400	Steering support, CW - black	1
	51100	suspension bushings	2 ea
	50152	bolt, 5/16 x 1	4
	50005	Nut, 5/16 keps	4
25	10502	Steering Wheel 13"	1
	10506	Center cap (screw, included with center cap)	1
	50081	bolt, 1/4 x 1 3/4	3
	50001	nut, 1/4 nylock	3
30	45402	Pedal assembly, CW - black	1
	50152	bolt, 5/16 x 1	6
	50081	bolt, 1/4 x 1 3/4"	1
	50159	bolt, 5/16 x 1 1/2	1
	50005	Nut, 5/16 keps	8
	50701	Washer, 5/16 flat	2

Reference Number	Part Number	Part Description 650cc Models	Quantity Required
31	11123	master cylinder	1
	50167	bolt, 5/16 x 2	2
	50005	Nut, 5/16 keps	2
	50806	Clevis, 5/16 rod end	1
	50077	Nut, 5/16" Hex SAE	1
32	11124	brake caliper	2
	11167	brake pads	4
	11168	brake pins	4
	11169	brake clips	4
	50826	Spacer Lock collar, 3/8	4
	50217	bolt, 3/8 x 1 1/2	4
	50013	nut, 3/8 keps	4
33	11127	Parking Brake	1
	50086	Bolt, 1/4 x 1 1/4	1
	50001	nut, 1/4" nylock	1
	50163	bolt, 5/16 x 3/4" NC	4
	50005	Nut, 5/16 keps	4
	50701	Washer, 5/16 flat	4
34	18038	Brake spreader	2
	50152	bolt, 5/16 x 1	4
	50007	nut, 5/16 nylock	1
35	11135	Brake hose, front	1
36	11136	Brake hose, rear	1
37	11085	Shifter control assembly, black	1
	11083	Knob	1
	11082	Cable, shifter	2
	50053	nut, #10-24 Keps nut	2
	50616	screw, #10-24 X 3/4" Pan Head phillips	2
	50770	Washer, #10 flat	2
38	11086	Differential Control Assy - 4x4 Diff Control w/ cable	1
	11083	Knob	
	11084	cable, diff lock	
	50053	nut, #10-24 Keps nut	2
	50616	screw, #10-24 X 3/4" Pan Head phillips	2
	50770	Washer, #10 flat	2
	50087	1/4-20 x 1" Hex Hd Bolt	1
	50000	1/4" Keps Nut	2
	50159	5/16-18 x 1 1/2" Hex Hd Bolt	1
	50005	5/16" Keps Nut	2
40	70053	Wire Harness 265/650	1
41	70000	Battery, U1L-8250-UTV	1
	70002	Battery Cable, Red - 17"	1
	70010	Battery Cable, Black (24")	1
	70009	Battery Terminal Cover	2
	50087	bolt, 1/4" x 1	2
	50000	nut, 1/4" keps	2

Reference Number	Part Number	Part Description 650cc Models	Quantity Required
42	45414	Battery strap, CW (8 3/4") - black	1
	50083	bolt, 1/4 x 7 1/2	2
	50002	nut, 1/4" wing	2
43	70055	Light Switch / 4x4 switch	2
44	70058	Key Switch	1
	70060	Key, 1 pair	
45	70080	Accessory Plug	1
	70081	Accessory Plug cap	1
46	18500	Terminal Block Cover - plastic	1
	50625	screw, #10-24 X 1" Pan Head phillips	2
	50053	nut, #10-24 Keps nut	2
47	70129	Headlights	2
48	70019	Relay w/harness, 4x4	1
50	18380	Hood, plastic - 4x4 (green)	1
	50620	1/4" X 1 1/4" Pan phillips Machine screw	2
	50621	1/4" X 2" Pan phillips Machine screw	2
	50717	1/4" SAE Flat washer	8
	50001	nut, 1/4" nylock	4
	50846	Clamp-Tube-vinyl coated 1-1/4"	2
51	18309	Glove Box	1
	50624	Screw, #10 x 3/4 hex - black	5
52	18308	Steering Cover	1
	50624	Screw, #10 x 3/4 hex - black	1
53	18383	Center Console 4x4	1
	50624	Screw, #10 x 3/4 hex - black	14
54	18316	Access Cover, Center Console	1
	50624	Screw, #10 x 3/4 hex - black	4
55	18382	Plastic, Seat Bottom wrap 4x4	1
	50624	Screw, #10 x 3/4 hex - black	5
56	18304	Underseat storage box	1
57	18303	Rear Fender - Left	1
	18310	Rear Fender - Right	1
	50001	nut, 1/4 nylock	4
	50091	1/4"-20 X 3/4" Carriage bolt	4
	50717	1/4" SAE Flat washer	4
58	18033	Shaft guard	1
	50163	bolt, 5/16 x 3/4" NC	3
	50005	Nut, 5/16 keps	4
	50171	Bolt, 5/16 x 3 3/4" USS	1
	10001	tube, 1" 14ga	1
60	10754	Seatback 43 1/2 x 17 1/2	1
	50619	#14 X 1-3/4" Pan head-Tapping screw	6
61	10803	Headrest - UTV 9 x 6 1/2	2
	50085	bolt, 1/4 x 1 1/2"	4
62	10755	Seat bottom 43 1/2 x 17 1/2	1
63	45416	seat bar, CW (17 1/2") - black	2
	50609	#14 x 3/4 pan head tapping	6

Reference Number	Part Number	Part Description 650cc Models	Quantity Required
65	8778	Seat Belt, 3pt Retr.	2
	50025	7/16 Nylock	4
70	45426	Cargo Bed, green	1
	50255	5/8 x 4" bolt Zinc plate	2
	50015	5/8 nylock	2
73	50208	Bed latch bolt, 3/8 x 2 1/2"	1
	50013	nut, 3/8 keps	2
	50740	washer, 3/8 flat	2
75	45427	Tail gate, green	1
	50152	bolt, 5/16 x 1	2
	50701	washer, 5/16 sae	4
	50007	nut, 5/16 nylock	2
	70230	rubber bump stops	4
78	50815	1/4" Lynch Pin - tailgate latch	2
80	18312	Roof, green	1
	50846	Clamp-Tube-vinyl coated 1-1/4"	4
	50087	bolt, 1/4" x 1	4
	50717	1/4" SAE Flat washer	4
	50001	nut, 1/4" nylock	4
85	18400	Windshield - clear	
	18401	Windshield - tinted	
	18403	Fastener kit, windsheild	
88	40729	Front reciever hitch 4x4 kit	1
	50162	Bolt, 5/16 x 1-3/8 - U	4
	50704	Washer, 5/16 Flat	8
	50007	Nut, 5/16 Nylock	8
101	20017	Engine, Subaru V-Twin 653cc	1
	50202	3/8-16 x 1 3/4" Hex Hd Bolt	4
	50740	3/8" Flatwasher, USS	4
102	20838	Dana Transaxle	1
103	45505	Swing arm 650 4x4 - Black	1
104	55043	Muffler 653cc Subaru	
107	20644	TC, Driver Comet 780	1
108	20645	TC, Driven Comet 780	1
109	11171	Brake Shoes - Rear UTV - Dana	2
110	50745	1" I.D. Spacer Washer	4
111	-	1/4 x 3/16" Keystock	1
112	50742	3/8" I.D. Fender Washer	1
113	50741	3/8" Lock Washer	1
114	50219	3/8x 3" Bolt Hex Hd NF	1
115	20697	Belt, Comet (EX9857)	1
116	50244	1/2 x 1-1/2" SAE	1
117	50722	1/2" Lock Washer	1
118	-	3/16" Key stock	1
	50157	5/16x 3/4" Bolt Hex Hd NF	2
	50703	5/16" Lock Washer	2
	50704	5/16" Flatwasher	2
121	10581	Rod End Sphcl-UTV (4681-MPM-12)	1

Reference Number	Part Number	Part Description 650cc Models	Quantity Required
122	50021	3/4 Jam nut SAE	3
123	42093	Panhard bar, CW 4x4 - black	1
124	50206	bolt, 3/8 x 1	4
	50010	3/8" Nylock Nut	4
	50740	3/8" Flatwasher, USS	4
125	50730	3/4" Spacer Washer	6
126	50280	3/4 x 2.5 SAE bolt	3
127	50020	3/4 SAE nylock	3
128	18012	shifter lever, CW - black	1
	50084	1/4-20 x 3/4" Hex Hd Bolt	2
	50000	1/4" Keps Nut	4
129	18011	shifter cable mount, CW - black	1
130	11104	Parking Brake Cables 4x4	2
	50150	5/16-18 x 1" Hex Hd Bolt	2
	50007	5/16" Nylock Nut	2
131	11010	Throttle Cable, UTV	1
	50087	1/4-20 x 1" Hex Hd Bolt	1
	50000	1/4" Keps Nut	2
	11804	Spring #80704 Black painted	1
133	11804	Spring #80704 Black painted	1
136	65500	fuel hose 3/16" dia - 24"	1
137	50849	hose clamps - small	3
138	18324	Belt Guard Plastic 650 UTV - Front	1
139	18320	Belt Guard Plastic 650 UTV - Rear	1
	50624	#10 x 3/4" Blunt Point Black	7
	50050	#10 Speed Nut - for Plastic	7
	50770	#10 Flatwasher	7
150	25004	right angle gearbox	1
	10184	Key, 3/16 x 1	3
151	20852	gearbox coupling	1
	50163	bolt, 5/16 x 3/4" NC	2
	50701	Washer, 5/16 flat	2
	50703	Washer, 5/16 lock	2
152	18083	Gear Box Mount	1
153	18032	diff lock mount	1
	50163	bolt, 5/16 x 3/4" NC	2
	50701	Washer, 5/16 flat	2
	50703	Washer, 5/16 lock	2

Copyright
January 12,
2010

**653cc
CW650 & TW650
4-wheel drive
Utility Vehicle
Parts Breakdown**

**MODELS MANUFACTURED
BEFORE AUGUST 2009**

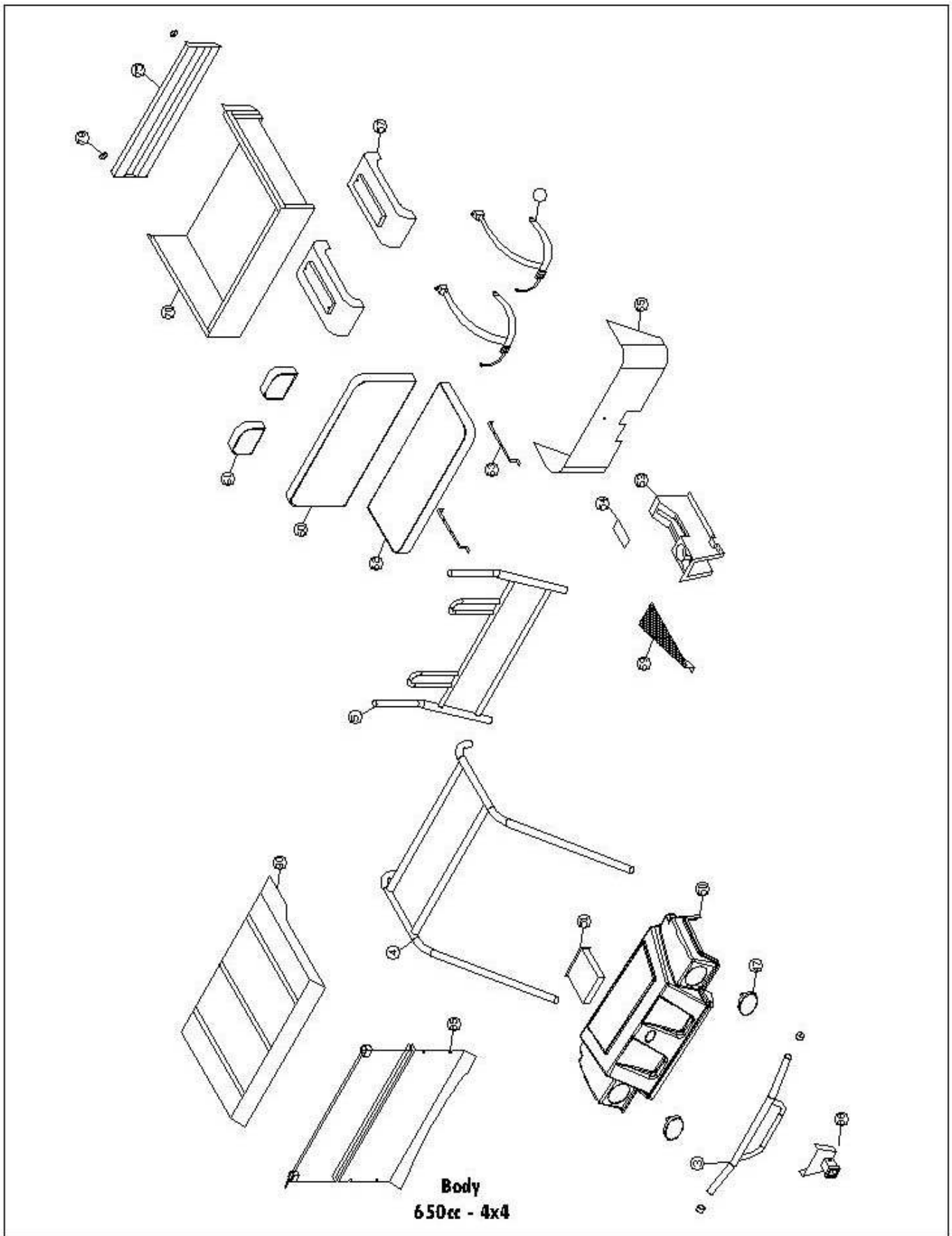

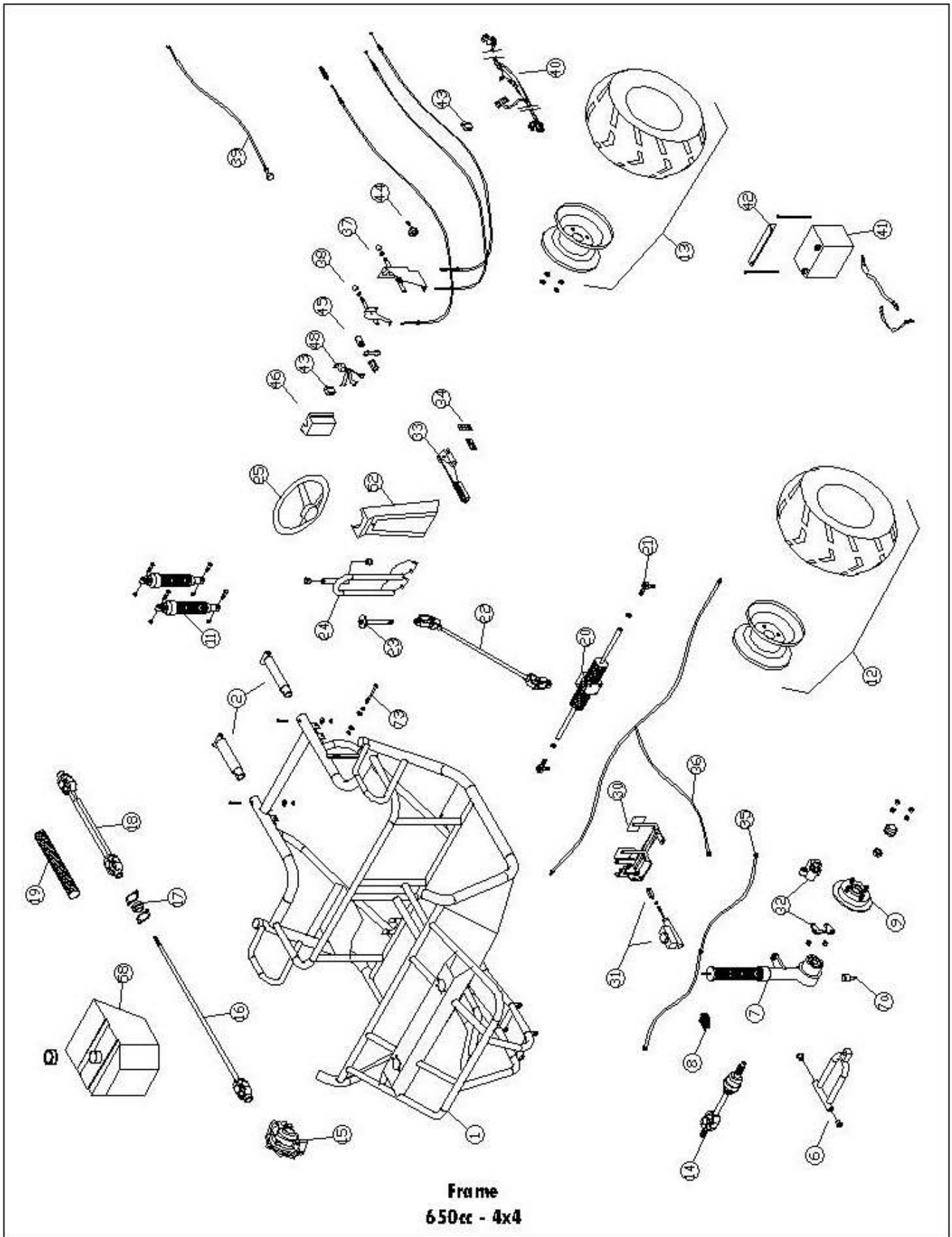

Frame
650cc - 4x4

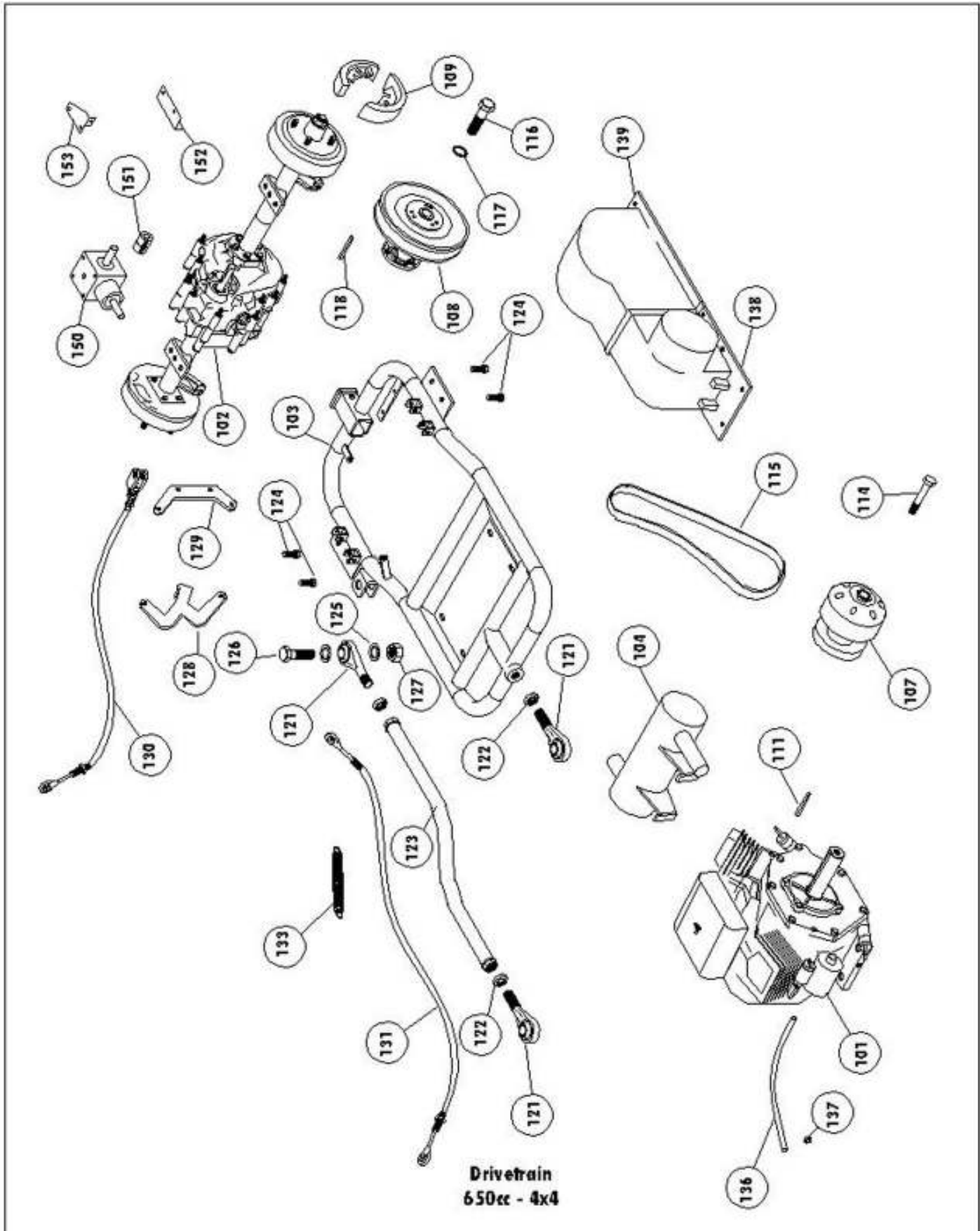

Models CW-650 & TW-650 Parts List (pre August 2009)

<i>Reference Number</i>	<i>Part Number</i>	<i>Part Description 650cc Models</i>	<i>Quantity Required</i>
1		Frame, - CW650 4x4	1
2	45401	Rear frame stub, CW - black	2
	50206	bolt, 3/8 x 1	8
	50013	nut, 3/8 keps	8
3	45413	bumper, CW - black	1
	50167	bolt, 5/16 x 2	4
	50007	nut, 5/16 nylock	4
	50702	bent washer 5/16	4
	70208	Vinyl Caps 1 3/4 x 1 1/2	2
4	45412	brshgrd roof, CW - black	1
	50168	5/16 x 2-1/4" USS Socket Head bolt	4
	50007	nut, 5/16 nylock	4
	50702	bent washer 5/16	4
5	45411	brshgrd seat back, CW - black	1
	50168	5/16 x 2-1/4" USS Socket Head bolt	2
	50007	nut, 5/16 nylock	2
	50702	bent washer 5/16	2
6	43007	A-arm 4x4, CW - black	2
	51100	suspension bushings	2 ea
	50266	bolt, 5/8 x 9 1/2"	1 ea
	50015	Nut, 5/8 nylock	1 ea
	10051	spacer, 5/8	1 ea
7	25012	Strut assembly, left	1
	25013	Strut assembly, right	1
	50028	Nut, 7/16 NF jam	2
	50041	Nut, 3/8 NF slotted	2
	50801	cotter pin 1/8" x 1	2
7a	25020	replacement ball joint	2
8	25003	strut bearing	2
	50163	bolt, 5/16 x 3/4" NC	8
	50005	Nut, 5/16 keps	8
9	25014	Hub / 8" rotor 4x4	2
	50040	Nut, 5/8 NF slotted	2
	30621	cotter pin	2
	30623	dust cap	2
	50060	Lug nuts, 1/2"	16
11	70301	Shock, Heavy duty #1	6
	50400	Bolt, 10 mm x 40mm	6
	50404	10 mm x 70mm bolt	2
	50065	Nut, 10mm nylock	8
	45150	spacer, shock	2
12L	30146	Rim/Tire Assembly, UTV 25/11-12" Left	1
12R	30147	Rim/Tire Assembly, UTV 25/11-12" Right	1
	30481	Wheel rim, 12"	
	30199	UTV 25/11-12 Tire only	
13L	30146	Rim/Tire Assembly, UTV 25/11-12" Left	1

Reference Number	Part Number	Part Description 650cc Models	Quantity Required
13R	30147	Rim/Tire Assembly, UTV 25/11-12" Right	1
	30481	Wheel rim, 12"	
	30199	UTV 25/11-12 Tire only	
14	20851	CV half shaft (axle)	2
15	20839	front differential - 4x4	1
	50206	Bolt, 3/8 x 1	4
	50740	washer, 3/8 flat	4
	50741	washer, 3/8 lock	4
16	25006	drive shaft, front	1
	50092	bolt, 1/4 x 2"	2
	50003	nut, 1/4 keps	2
17	25008	bearing, shaft support	1
	50163	bolt, 5/16 x 3/4" NC	2
	50005	Nut, 5/16 keps	2
18	25007	drive shaft, rear telescoping	1
	50628	Screw, 1/4-20 x 1/2" square head set	1
	10184	key, 3/16 x 1	3
19	20804	convoluted tubing	17 inch
20	10591	Rack & pinion with rod ends 4x4	1
	50171	Bolt, 5/16 x 3 3/4" USS	4
	50005	Nut, 5/16 keps	4
21	10594	Rod end 4x4	2
	10595	Tie rod 4x4	2
	10593	Rack boot	2
22	10592	Steering Shaft w/u-joints 4x4	1
	50402	Bolt, 10mm x 30mm	1
	50066	Nut, 10mm Tri Lock Jam	1
	50403	Bolt, 8mm x 30mm	1
	50780	Lock washer, 8mm	1
23	45422	Steering Stub Shaft Assembly, CW - Black	1
24	45400	Steering support, CW - black	1
	51100	suspension bushings	2 ea
	50152	bolt, 5/16 x 1	4
	50005	Nut, 5/16 keps	4
25	10502	Steering Wheel 13"	1
	10506	Center cap	
		screw, included with center cap	
	50081	bolt, 1/4 x 1 3/4	3
	50001	nut, 1/4 nylock	3
30	45402	Pedal assembly, CW - black	1
	50152	bolt, 5/16 x 1	6
	50081	bolt, 1/4 x 1 3/4"	1
	50159	bolt, 5/16 x 1 1/2	1
	50005	Nut, 5/16 keps	8
	50701	Washer, 5/16 flat	2

Reference Number	Part Number	Part Description 650cc Models	Quantity Required
31	11123	master cylinder	1
	50167	bolt, 5/16 x 2	2
	50005	Nut, 5/16 keps	2
	50806	Clevis, 5/16 rod end	1
	50077	Nut, 5/16" Hex SAE	1
32	11124	brake caliper	2
	11167	brake pads	4
	11168	brake pins	4
	11169	brake clips	4
	50826	Spacer Lock collar, 3/8	4
	50217	bolt, 3/8 x 1 1/2	4
	50013	nut, 3/8 keps	4
	18030	caliper bracket	2
33	11127	Parking Brake	1
	50086	Bolt, 1/4 x 1 1/4	1
	50001	nut, 1/4" nylock	1
	50163	bolt, 5/16 x 3/4" NC	4
	50005	Nut, 5/16 keps	4
	50701	Washer, 5/16 flat	4
34	18038	Brake spreader	2
	50152	bolt, 5/16 x 1	4
	50007	nut, 5/16 nylock	1
35	11135	Brake hose, front	1
36	11136	Brake hose, rear	1
37	11085	Shifter control assembly, black	1
	11083	Knob	1
	11082	Cable, shifter	2
	50053	nut, #10-24 Keps nut	2
	50616	screw, #10-24 X 3/4" Pan Head phillips	2
	50770	Washer, #10 flat	2
38	11086	Differential Control Assy - 4x4 Diff Control w/ cable	1
	11083	Knob	
	11084	cable, diff lock	
	50053	nut, #10-24 Keps nut	2
	50616	screw, #10-24 X 3/4" Pan Head phillips	2
	50770	Washer, #10 flat	2
	50087	1/4-20 x 1" Hex Hd Bolt	1
	50000	1/4" Keps Nut	2
	50159	5/16-18 x 1 1/2" Hex Hd Bolt	1
	50005	5/16" Keps Nut	2
40	70053	Wire Harness 265/650	1
41	70000	Battery, U1L-8250-UTV	1
	70002	Battery Cable, Red - 17"	1
	70010	Battery Cable, Black (24")	1
	70009	Battery Terminal Cover	2
	50087	bolt, 1/4" x 1	2
	50000	nut, 1/4" keps	2

Reference Number	Part Number	Part Description 650cc Models	Quantity Required
42	45414	Battery strap, CW (8 3/4") - black	1
	50083	bolt, 1/4 x 7 1/2	2
	50002	nut, 1/4" wing	2
43	70055	Light Switch / 4x4 switch	2
44	70058	Key Switch	1
	70060	Key, 1 pair	
45	70080	Accessory Plug	1
	70081	Accessory Plug cap	1
46	18500	Terminal Block Cover - plastic	1
	50625	screw, #10-24 X 1" Pan Head phillips	2
	50053	nut, #10-24 Keps nut	2
47	70129	Headlights	2
48	70019	Relay w/harness, 4x4	1
50	18380	Hood, plastic - 4x4 (green)	1
	50620	1/4" X 1 1/4" Pan phillips Machine screw	2
	50621	1/4" X 2" Pan phillips Machine screw	2
	50717	1/4" SAE Flat washer	8
	50001	nut, 1/4" nylock	4
	50846	Clamp-Tube-vinyl coated 1-1/4"	2
51	18309	Glove Box	1
	50624	Screw, #10 x 3/4 hex - black	5
52	18308	Steering Cover	1
	50624	Screw, #10 x 3/4 hex - black	1
53	18383	Center Console 4x4	1
	50624	Screw, #10 x 3/4 hex - black	14
54	18316	Access Cover, Center Console	1
	50624	Screw, #10 x 3/4 hex - black	4
55	18382	Plastic, Seat Bottom wrap 4x4	1
	50624	Screw, #10 x 3/4 hex - black	5
56	18304	Underseat storage box	1
57	18303	Rear Fender - Left	1
	18310	Rear Fender - Right	1
	50001	nut, 1/4 nylock	4
	50091	1/4"-20 X 3/4" Carriage bolt	4
	50717	1/4" SAE Flat washer	4
58	18033	Shaft guard	1
	50163	bolt, 5/16 x 3/4" NC	3
	50005	Nut, 5/16 keps	4
	50171	Bolt, 5/16 x 3 3/4" USS	1
	10001	tube, 1" 14ga	1
60	10754	Seatback 43 1/2 x 17 1/2	1
	50619	#14 X 1-3/4" Pan head-Tapping screw	6
61	10803	Headrest - UTV 9 x 6 1/2	2
	50085	bolt, 1/4 x 1 1/2"	4
62	10755	Seat bottom 43 1/2 x 17 1/2	1
63	45416	seat bar, CW (17 1/2") - black	2
	50609	#14 x 3/4 pan head tapping	6

Reference Number	Part Number	Part Description 650cc Models	Quantity Required
65	8778	Seat Belt, 3pt Retr.	2
	50025	7/16 Nylock	4
70	45426	Cargo Bed, green	1
	50255	5/8 x 4" bolt Zinc plate	2
	50015	5/8 nylock	2
73	50208	Bed latch bolt, 3/8 x 2 1/2"	1
	50013	nut, 3/8 keps	2
	50740	washer, 3/8 flat	2
75	45427	Tail gate, green	1
	50152	bolt, 5/16 x 1	2
	50701	washer, 5/16 sae	4
	50007	nut, 5/16 nylock	2
	70230	rubber bump stops	4
78	50815	1/4" Lynch Pin - tailgate latch	2
80	18312	Roof, green	1
	50846	Clamp-Tube-vinyl coated 1-1/4"	4
	50087	bolt, 1/4" x 1	4
	50717	1/4" SAE Flat washer	4
	50001	nut, 1/4" nylock	4
85	18400	Windshield - clear	
	18401	Windshield - tinted	
	18403	Fastener kit, windsheild	
88	40729	Front reciever hitch 4x4 kit	1
	50162	Bolt, 5/16 x 1-3/8 - U	4
	50704	Washer, 5/16 Flat	8
	50007	Nut, 5/16 Nylock	8
101	20017	Engine, Subaru V-Twin 653cc	1
	50202	3/8-16 x 1 3/4" Hex Hd Bolt	4
	50740	3/8" Flatwasher, USS	4
102	20833	Dana Transaxle	1
103	45505	Swing arm 650 4x4 - Black	1
104	55043	Muffler 653cc Subaru	
107	20644	TC, Driver Comet 780	1
108	20645	TC, Driven Comet 780	1
109	11171	Brake Shoes - Rear UTV - Dana	2
110	50745	1" I.D. Spacer Washer	4
111	-	1/4 x 3/16" Keystock	1
112	50742	3/8" I.D. Fender Washer	1
113	50741	3/8" Lock Washer	1
114	50219	3/8x 3" Bolt Hex Hd NF	1
115	20697	Belt, Comet (EX9857)	1
116	50244	1/2 x 1-1/2" SAE	1
117	50722	1/2" Lock Washer	1
118	-	3/16" Key stock	1
	50157	5/16x 3/4" Bolt Hex Hd NF	2
	50703	5/16" Lock Washer	2
	50704	5/16" Flatwasher	2
121	10581	Rod End Sphcl-UTV (4681-MPM-12)	1

Reference Number	Part Number	Part Description 650cc Models	Quantity Required
122	50021	3/4 Jam nut SAE	3
123	42093	Panhard bar, CW 4x4 - black	1
124	50206	bolt, 3/8 x 1	4
	50010	3/8" Nylock Nut	4
	50740	3/8" Flatwasher, USS	4
125	50730	3/4" Spacer Washer	6
126	50280	3/4 x 2.5 SAE bolt	3
127	50020	3/4 SAE nylock	3
128	18012	shifter lever, CW - black	1
	50084	1/4-20 x 3/4" Hex Hd Bolt	2
	50000	1/4" Keps Nut	4
129	18011	shifter cable mount, CW - black	1
130	11104	Parking Brake Cables 4x4	2
	50150	5/16-18 x 1" Hex Hd Bolt	2
	50007	5/16" Nylock Nut	2
131	11010	Throttle Cable, UTV	1
	50087	1/4-20 x 1" Hex Hd Bolt	1
	50000	1/4" Keps Nut	2
	11804	Spring #80704 Black painted	1
133	11804	Spring #80704 Black painted	1
136	65500	fuel hose 3/16" dia - 24"	1
137	50849	hose clamps - small	3
138	18324	Belt Guard Plastic 650 UTV - Front	1
139	18320	Belt Guard Plastic 650 UTV - Rear	1
	50624	#10 x 3/4" Blunt Point Black	7
	50050	#10 Speed Nut - for Plastic	7
	50770	#10 Flatwasher	7
150	25004	right angle gearbox	1
	10184	Key, 3/16 x 1	3
151	20852	gearbox coupling	1
	50163	bolt, 5/16 x 3/4" NC	2
	50701	Washer, 5/16 flat	2
	50703	Washer, 5/16 lock	2
152	18083	Gear Box Mount	1
153	18032	diff lock mount	1
	50163	bolt, 5/16 x 3/4" NC	2
	50701	Washer, 5/16 flat	2
	50703	Washer, 5/16 lock	2

**48 Volt
CW48V & BD48V
2-wheel drive
Electric
Utility Vehicle
Parts Breakdown**

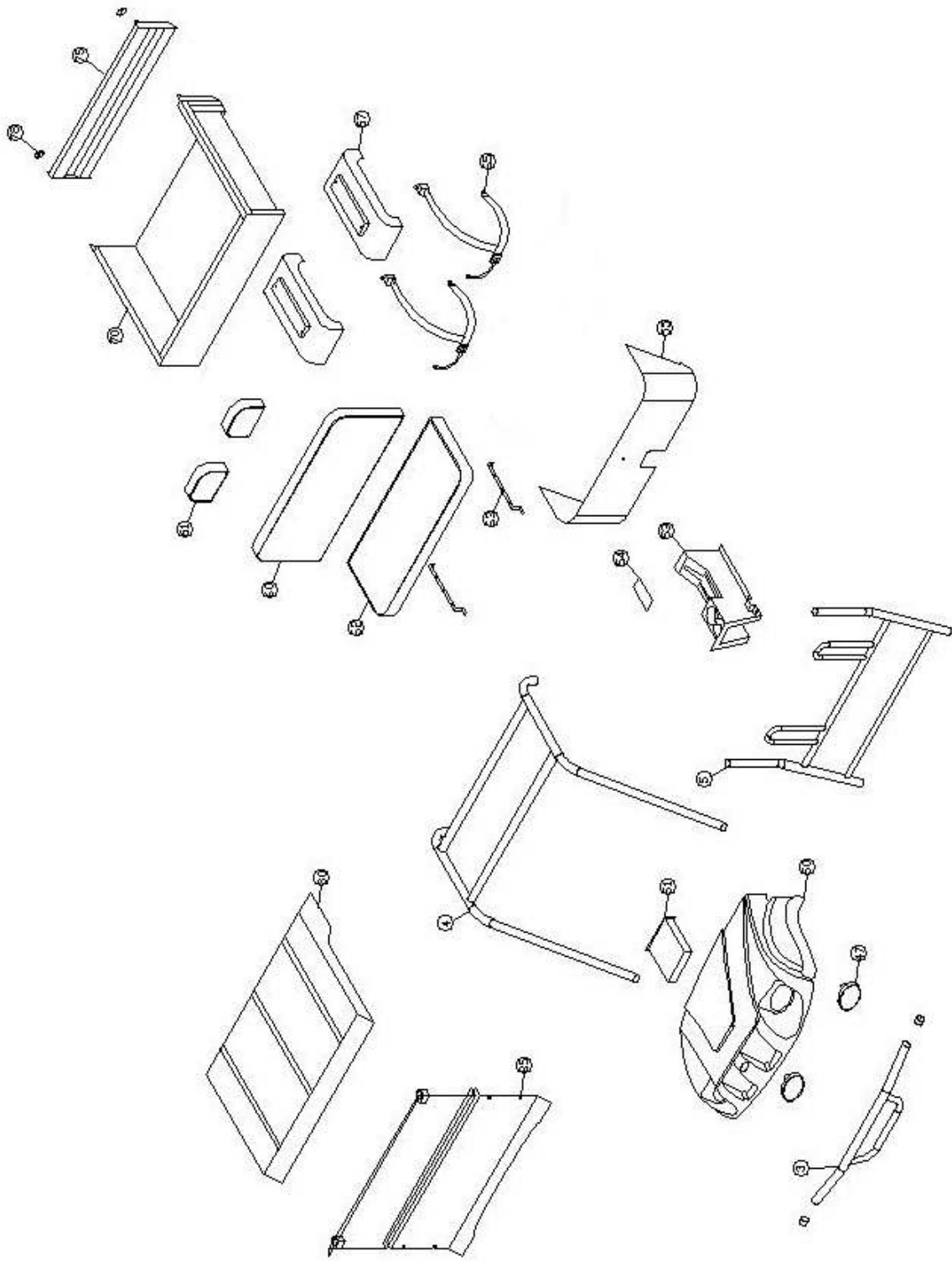

**48V Models
Body**

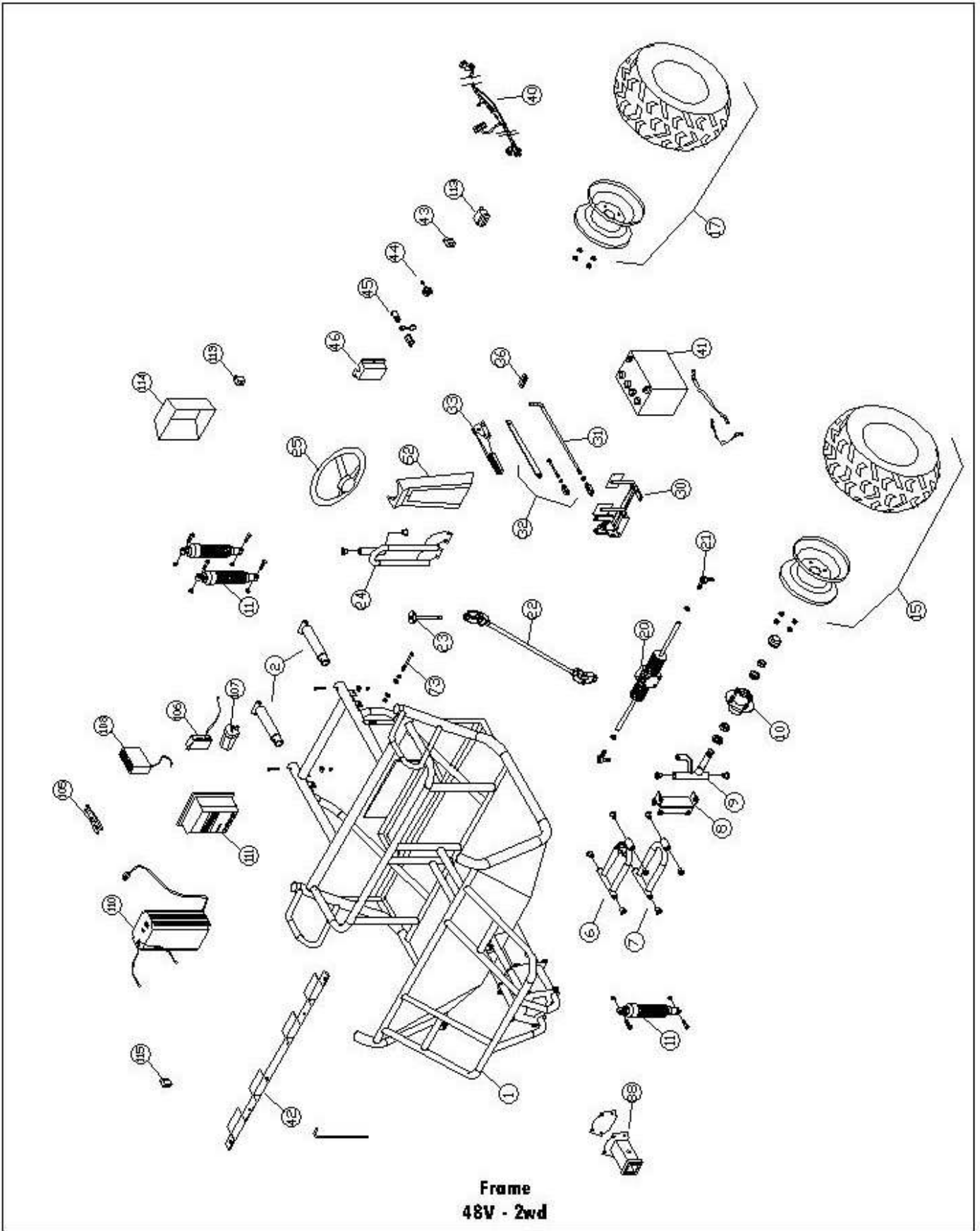

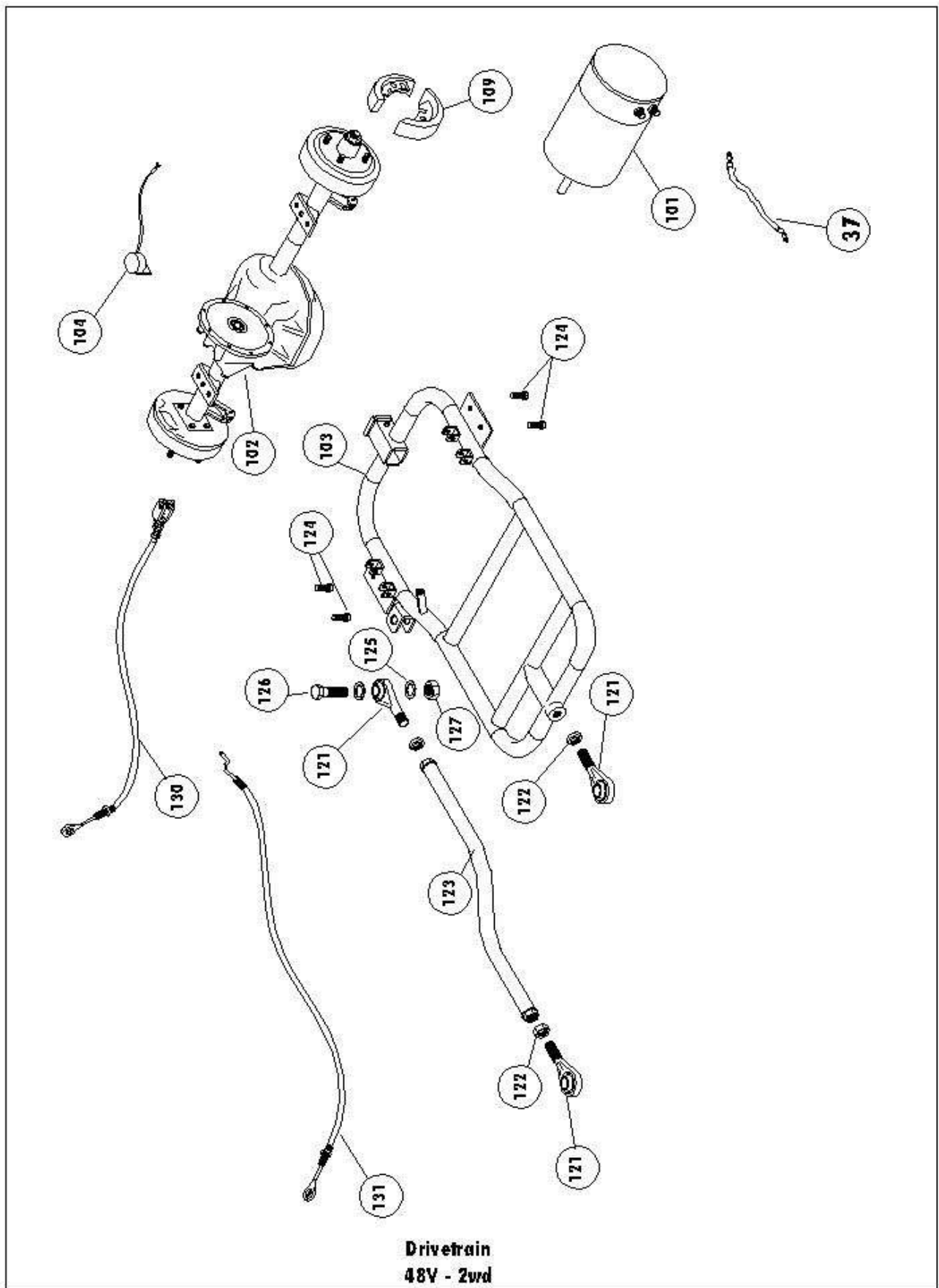

Reference Number	Part Number	Part Description – 48V Models	Quantity Required
1	XXXXXX	Frame, CW48V	1
2	45401	Rear frame stub, CW - black	2
	50168	5/16 x 2-1/4" USS Socket Head bolt	2
	50007	nut, 5/16 nylock	2
	50702	bent washer 5/16	2
3	45413	bumper, CW - black	1
	45432	Bumper, Trail Wagon – Black	1
	50167	bolt, 5/16 x 2	4
	50007	nut, 5/16 nylock	4
	50702	bent washer 5/16	4
	70208	Vinyl Caps 1 3/4 x 1 1/2	2
4	45412	Brush Guard roof, CW – black	1
	50168	5/16 x 2-1/4" USS Socket Head bolt	4
	50007	nut, 5/16 nylock	4
	50702	bent washer 5/16	4
5	45411	brshgrd seat back, CW – black	1
	50168	5/16 x 2-1/4" USS Socket Head bolt	2
	50007	nut, 5/16 nylock	2
	50702	bent washer 5/16	2
6	45404	A-arm upper, CW – black (left or right)	2
	51100	suspension bushings	4 ea
	50262	bolt, 5/8 x 9"	1 ea
	50254	Bolt, 5/8 x 3.5 bolt	1 ea
	50015	Nut, 5/8 nylock	2 ea
7	45405	A-arm Lower, CW – black (left or right)	2
	51100	suspension bushings	4 ea
	50262	bolt, 5/8 x 9"	1 ea
	50254	Bolt, 5/8 x 3.5 bolt	1 ea
	50015	Nut, 5/8 nylock	2 ea
8	45408	spindle mount, CW – black	2
9a	45406	Spindle, cw left – black	1
9b	45407	Spindle, cw right – black	1
	51100	suspension bushings	2 ea
	50262	bolt, 5/8 x 9"	1 ea
	50015	Nut, 5/8 nylock	1 ea
10	30604	Hub, 4 bolt high speed 1" Complete with Bearings & Seals	2
	11205	bearing, 1" tapered	
	30620	seal	
	30622	castle nut, 1"	
	30621	cotter pin	
	30623	dust cap	

Reference Number	Part Number	Part Description – 48V Models	Quantity Required
	50060	Lug nuts, ½”	
11	70301	Shock, Heavy duty #1	6
	50400	Bolt, 10 mm x 40mm	12
	50065	Nut, 10mm nylock	12
15L	30148	Rim/Tire Assembly, UTV 22/11-10” Left	1
15R	30148	Rim/Tire Assembly, UTV 22/11-10” Right	1
	30480	Wheel rim, 10” x 6”	
	30197	Tire, Terra Trac	
17L	30148	Rim/Tire Assembly, UTV 22/11-10” Left	1
17R	30148	Rim/Tire Assembly, UTV 22/11-10” Right	1
	30480	Wheel rim, 10” x 6”	
	30197	Tire, Terra Trac	
20	10521	Rack & pinion with rod ends	1
	10593	Rack & Pinion Boots	2
	10590	Rack & Pinion Rod	2
	50171	Bolt, 5/16 x 3 ¾” USS	4
	50005	Nut, 5/16 keps	4
	50063	Nut, ½” SAE nylock	2
21	10524	Rod end “ use before serial #27214”	2
	10597	Rod end “ use after serial #27213”	2
	50078	Nut, ½” SAE jam	2
22	10522	Steering Shaft w/u-joints	1
	50402	Bolt, 10mm x 30mm	1
	50066	Nut, 10mm Tri Lock Jam	1
	50403	Bolt, 8mm x 30mm	1
	50780	Lock washer, 8mm	1
23	45422	Steering Stub Shaft Assembly, CW – Black	1
24	45400	Steering support, CW – black	1
	51100	suspension bushings	2 ea
	50152	bolt, 5/16 x 1	4
	50005	Nut, 5/16 keps	4
25	10502	Steering Wheel 13”	1
	10506	Center cap	
		screw, included with center cap	
	50081	bolt, ¼ x 1 ¾	3
	50001	nut, ¼ nylock	3
30	45402	Pedal assembly, CW – black	1
	50152	bolt, 5/16 x 1	6
	50081	bolt, ¼ x 1 ¾”	1
	50159	bolt, 5/16 x 1 ½	1
	50005	Nut, 5/16 keps	8
	50701	Washer, 5/16 flat	2

Reference Number	Part Number	Part Description – 48V Models	Quantity Required
31	11180	Brake Rod, with clevis	1
	50215	bolt, 3/8 x 1 1/4	1
	50010	nut, 3/8" nylock	1
	50801	cotter pin 1/8" x 1	1
32	45417	parking brake bar, CW – black	1
	50806	Clevis, 5/16 rod end	1
	50170	Bolt, 5/16"-24 X 4" SAE	1
	50077	Nut, 5/16" Hex SAE	1
	50087	bolt, 1/4" x 1	1
	50001	nut, 1/4" nylock	1
33	11127	Parking Brake	1
	50086	Bolt, 1/4 x 1 1/4	1
	50001	nut, 1/4" nylock	1
	50163	bolt, 5/16 x 3/4" NC	4
	50005	Nut, 5/16 keps	4
	50701	Washer, 5/16 flat	4
36	45415	Brake equalizer, CW (2 1/2") – black	1
	50215	bolt, 3/8 x 1 1/4	2
	50010	nut, 3/8" ny-lock	2
37	69901	Battery Cable 20"x 5/16"x 5/16"	1
	69902	Battery Cable 20"x 5/16"x 3.8"	1
	69903	Battery Cable 20"x 1/4"x 1/4"	2
	69904	Battery Cable 16"x 5/16"x 5/16"	1
	69905	Battery Cable 10.5"x 5/16"x 5/16"	2
	69906	Battery Cable 10.5"x 5/16"x 3.8"	2
40	70118	Wire Harness 48V	1
41	70001	Battery, Trojan	6
	70002	Battery Cable, Red – 17"	1
	70010	Battery Cable, Black (24")	1
	70009	Battery Terminal Cover	2
	50087	bolt, 1/4" x 1	2
	50000	nut, 1/4" keps	2
42	45507	Battery Hold Down Electric	1
	50223	L bolt-Special	4
43	70055	Light Switch	1
44	70052	Key Switch	1
	70060	Key, 1 pair	

Reference Number	Part Number	Part Description – 48V Models	Quantity Required
45	70080	Accessory Plug	1
	70081	Accessory Plug cap	1
46	18500	Terminal Block Cover – plastic	1
	50625	screw, #10-24 X 1" Pan Head Phillips	2
47	50053	nut, #10-24 Keps nut	2
	70129	Headlights	2
	70055	Switch Headlights	1
50	18311	Hood, plastic Green	1
	18302	Hood, plastic Red	
	18350	Hood, plastic Camo	
	50620	¼" X 1 ¼" Pan Head Phillips Machine screw	2
	50621	¼" X 2" Pan Head Phillips Machine screw	2
	50717	¼" SAE Flat washer	8
	50001	nut, ¼" nylock	4
	50846	Clamp-Tube-vinyl coated 1-1/4"	2
	51	18309	Glove Box
	50624	Screw, #10 x ¾ hex – black	5
	52	18308	Steering Cover
	18317	Steering Cover Bottom	1
	50624	Screw, #10 x ¾ hex – black	1
	53	18306	Center Console
	50624	Screw, #10 x ¾ hex – black	14
	54	18316	Access Cover, Center Console
	50624	Screw, #10 x ¾ hex – black	4
	55	18305	Plastic, Seat Bottom wrap
	50624	Screw, #10 x ¾ hex – black	5
57	18303	Rear Fender	1
	50001	nut, ¼ nylock	4
	50091	¼"-20 X ¾" Carriage bolt	4
	50717	¼" SAE Flat washer	4
	70150	Reflectors	2
60	10754	Seatback 43 ½ x 17 ½	1
	50619	#14 X 1-3/4" Pan head-Tapping screw	6
61	10803	Headrest – UTV 9 x 6 ½	2
	50085	bolt, ¼ x 1 ½"	4
62	10755	Seat bottom 43 ½ x 17 ½	1
63	45416	seat bar, CW (17 ½") – black	2
	50609	#14 x ¾ Pan Head Screw	6
65	8778	Seat Belt, 3pt	2
	50025	7/16 Nylock	4

Reference Number	Part Number	Part Description – 48V Models	Quantity Required
70	45426	Cargo Bed, Green	1
	45420	Cargo Bed, Red	1
	45424	Cargo Bed, Black	1
	18352	Camo Bed Panel Left	1
	18353	Camo Bed Panel Right	1
	18354	Camo Bed Panel Tail Gate	1
	50255	5/8 x 4" bolt Zinc plate	2
	50015	5/8 nylock	2
	18402	Bed Rubber Plug	2
73	50208	Bed latch bolt, 3/8 x 2 1/2"	1
	50013	nut, 3/8 keps	2
	50740	washer, 3/8 flat	2
75	45427	Tail gate, green	1
	45421	Tail gate, Red	1
	45425	Tail gate, Black	1
	50152	bolt, 5/16 x 1	2
	50701	washer, 5/16 sae	4
	50007	nut, 5/16 nylock	2
	70230	rubber bump stops	4
78	50815	1/4" Lynch Pin - tailgate latch	2
80	18312	Roof, green	1
	18301	Roof, Red	1
	18351	Roof, Camo	1
	18391	Roof, Top Vinyl Trim	1
	18390	Roof, Hardware bolt kit	
	50847	Clamp-Tube-vinyl coated 1-3/4"	4
	50087	bolt, 1/4" x 1	4
	50718	Washer, 1/4" rubber domed	4
	50001	nut, 1/4" nylock	4
85	18400	Windshield - clear	
	18401	Windshield - tinted	
	18403	Fastener kit, windshield	
88	40723	Front receiver hitch kit	
101	20120	Motor (D&D)	1
102	20835	Dana Transaxle Electric	1
103	45504	Swing arm, CW 48V- Black	1
104	70117	Reverse Alarm	1
105	70020	500 Amp Fuse	1

	Part Number	Part Description – 48V Models	Quantity Required
106	70112	Potentiometer (Curtis)	1
107	70114	Solenoid / Contactor(Curtis)	1
108	70115	Converter	1
109	11171	Brake Shoes - Rear UTV –Electric Dana “1 set for each wheel”	2
110	70116	Charger	1
111	70111	Controller (Curtis)	1
112	70550	Mode Switch	1
113	70113	Charge Gauge	1
114	18318	Plastic Cover for Controller	1
115	70119	FNR Switch	1
121	10581	Rod End Sphcl-UTV (4681-MPM-12)	3
122	50021	3/4 Jam nut SAE	3
123	45403	Panhard bar, CW - black	1
124	50206	bolt, 3/8 x 1	4
	50010	3/8" Nylock Nut	4
	50740	3/8" Flatwasher, USS	4
125	50730	3/4" Spacer Washer	6
126	50280	3/4 x 2.5 SAE bolt	3
127	50020	3/4 SAE nylock	3
130	11103	Brake Cables	2
	50150	5/16-18 x 1" Hex Hd Bolt	2
	50007	5/16" Nylock Nut	2
131	11014	Throttle Cable, Electric 48V	1
	50087	1/4-20 x 1" Hex Hd Bolt	1
	50000	1/4" Keps Nut	2

Low Speed Vehicle (LSV) Owner/Operators Manual Insert

This low speed vehicle may be used on public roads (check local ordinances). This vehicle does NOT have comparable crash protection to a car or truck. Follow all safety procedures. Avoid roads with considerable traffic. Avoid driving on public roads at night or in low visibility. Never drink and drive.

▲ WARNING ▲ ADVERTENCIA

OBSERVE THE FOLLOWING INSTRUCTIONS
Failure to understand and follow Warnings and Instructions for the safe use and maintenance of this product may result in **Death or Injury!**

- Read owner/operator manuals carefully.
- This low speed vehicle may be used on public roads (check local ordinances).
- Always wear a D.O.T. - approved motorcycle helmet, eye protection, and protective clothing.
- Do NOT operate the vehicle without the brush bars securely in place.
- Keep all covers and shields properly installed.
- Throttle, Stop Switch, and Brake Controls must work properly and freely before starting the engine.
- Operator must be seated, safety belt must be fastened, and brake applied before operating the vehicle.
- This vehicle does not have the same protection as a car or truck in the event of an accident.
- **Avoid driving on public roads at night or in low visibility.**
- **Avoid roads with considerable traffic.**
- Follow all safety procedures.
- Never ride after consuming alcohol, drugs, or other intoxicants.

If you did not receive any of the material listed above, please call 1-800-643-7332 and request to have them sent to you at no charge.

OBSERVAR LAS SIGUIENTES INSTRUCCIONES
Al fallar o el no entender estos siguientes avisos y instrucciones para la seguridad y el mantenimiento de este producto puede resultar en un **Accidente o hasta la Muerte!**

- Lee los manuales de dueño/operador cuidadosamente.
- Este baja velocidad del vehículo puede ser utilizado en la vía pública (consulte la programación local ordenanzas).
- Todo el tiempo use un casco que sea aprobado por el DDT, protección para los ojos, y ropa protectora.
- **NUNCA** apere el vehículo sin que las barras de seguridad estén puestas en el lugar apropiado.
- Mantenga todas las coberturas y los protectores instalados apropiadamente.
- El acelerador, el botón de parar y el control de frenos tiene que trabajar apropiadamente y libremente antes de prender el motor.
- El operador tiene que estar sentado, tiene que asegurarse con el cinto de seguridad, y aplicar el freno antes de operar el vehículo.
- Este vehículo no tiene la misma protección que un coche o camión en caso de un accidente
- **Evite conducir en la via publica por la noche o en baja visibilidad**
- **Evitar carreteras con mucho trafico**
- **Siga todos los procedimientos de seguridad**
- Nunca maneje antes de consumir alcohol, drogar, o alguna otra sustancia toxica.....

Si no recibió cualquiera del material alistado arriba, por favor llame al 1-800-643-7332 y pida que envíen sin cargo alguno.

American SportWork's LSV/UTV models are equipped with certain parts unique to these models only. Special care and attention may be required during maintenance of these vehicles.

- **Turn Signal Control Switch - part # 2-70140**
- **Front Amber Turn Signal Lamp - part # 2-70143**
- **Rear Red Turn Signal Lamp - part # 2-70142**
- **Turn Signal Control Module(Grote) - part # 2-70141**
- **Blue Pigtail Plugs for front and rear Lamps - part # 2-70144**
- **Turn Signal Wiring Harness - part # 2-70051**
- **Plastic Turn Signal Switch Cover - part # 2-18318**
- **Lexan Polycarbonate Windshield - part# 2-18410**
- **Dana Transaxle H12 High Speed - part # 2-20840**
- **SeatBelts Retractable (LSV) - part # 2-10706**
- **RearView Mirror - part # 2-55081**
- **Horn - part # 2-55033**



Turn Signal Controls

MultiFunction Stalk -----Turn Signals/Horn/Headlights

The Multi-Function Stalk is a multi-feature control. It is located on the left side of the steering wheel and functions similar to an automobile for turn signaling but also includes the headlamp and horn control.

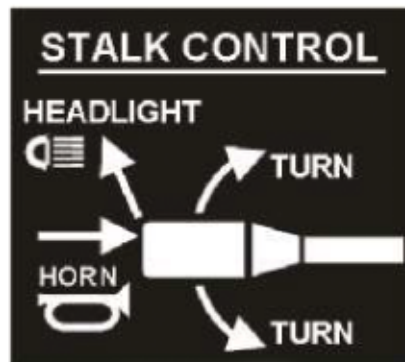

Turn Signal -- Pushing down on the stalk indicates a left turn, pushing up a right turn. *Note: the turn signal stalk will not automatically return to the off position after a turn, the operator should manually move the stalk to the center position upon completing each turn.*

Cleaning Your LSV Windshield

- Rinse windshield with lukewarm water; wash gently with mild soap or detergent and lukewarm water, using a soft cloth or sponge. DO NOT SCRUB or use brushes or squeegees.
 - Rinse again. Dry with soft cloth or moist cellulose sponge to prevent water spotting.
- Abusive cleaning procedures by hand washing or automated washing equipment will eventually result in visual hazing, loss of light transmission and coating contamination.

Compatible Cleaning Agents

Aqueous Solutions (Mix With Water) of Soaps and Detergents

Fantastik, Formula 409, Hexcel, F.O. 554, Joy, Lysol, Mr. Clean, Neleco-Placer, Pine-Sol, Top Job, Windex.

Wiring of Tail Lights

After installation of the fenders, the tail lights must be wired. The wire harness is routed through the holes in the fender. Please note that these fender holes face inward after mounting.

As in the photos below, the **FLAG COLOR** on the harness wire is plugged into the corresponding **WIRE COLOR** on the taillight end. Note that these colors are not the same on the left as the right.

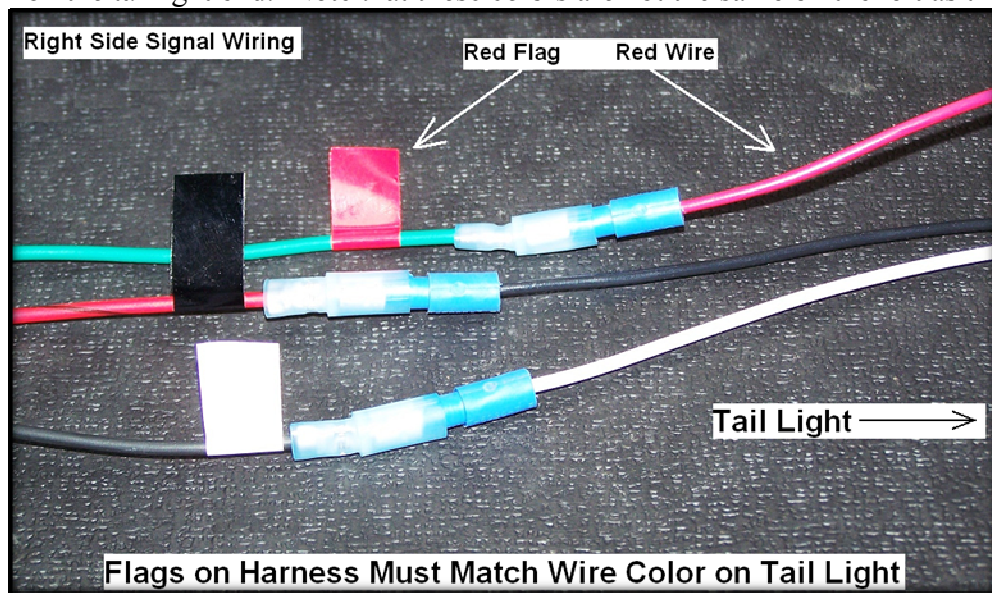

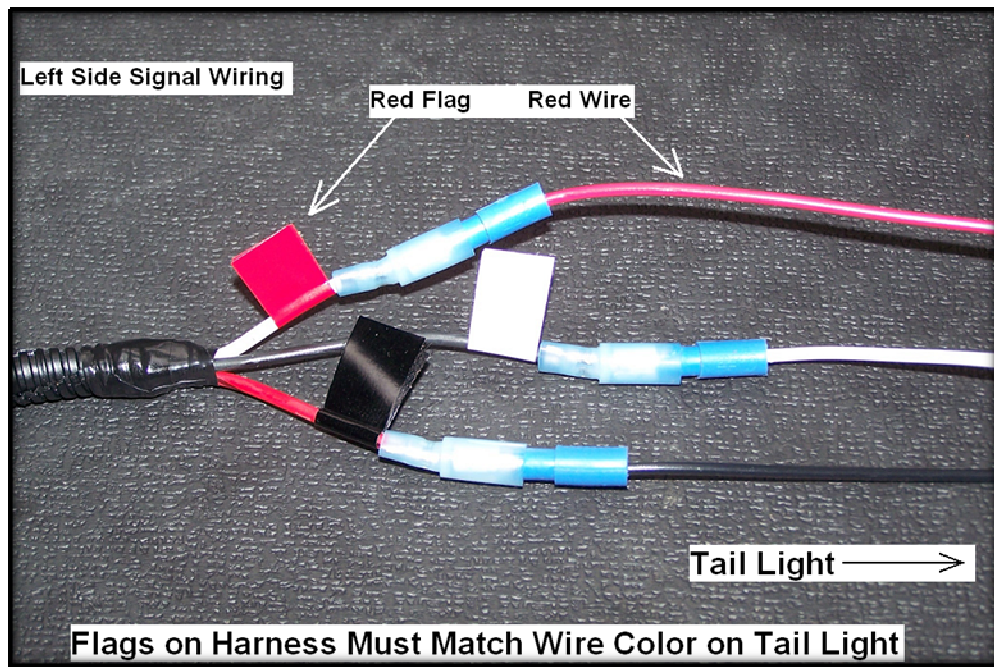

LSV48V Wiring Harness

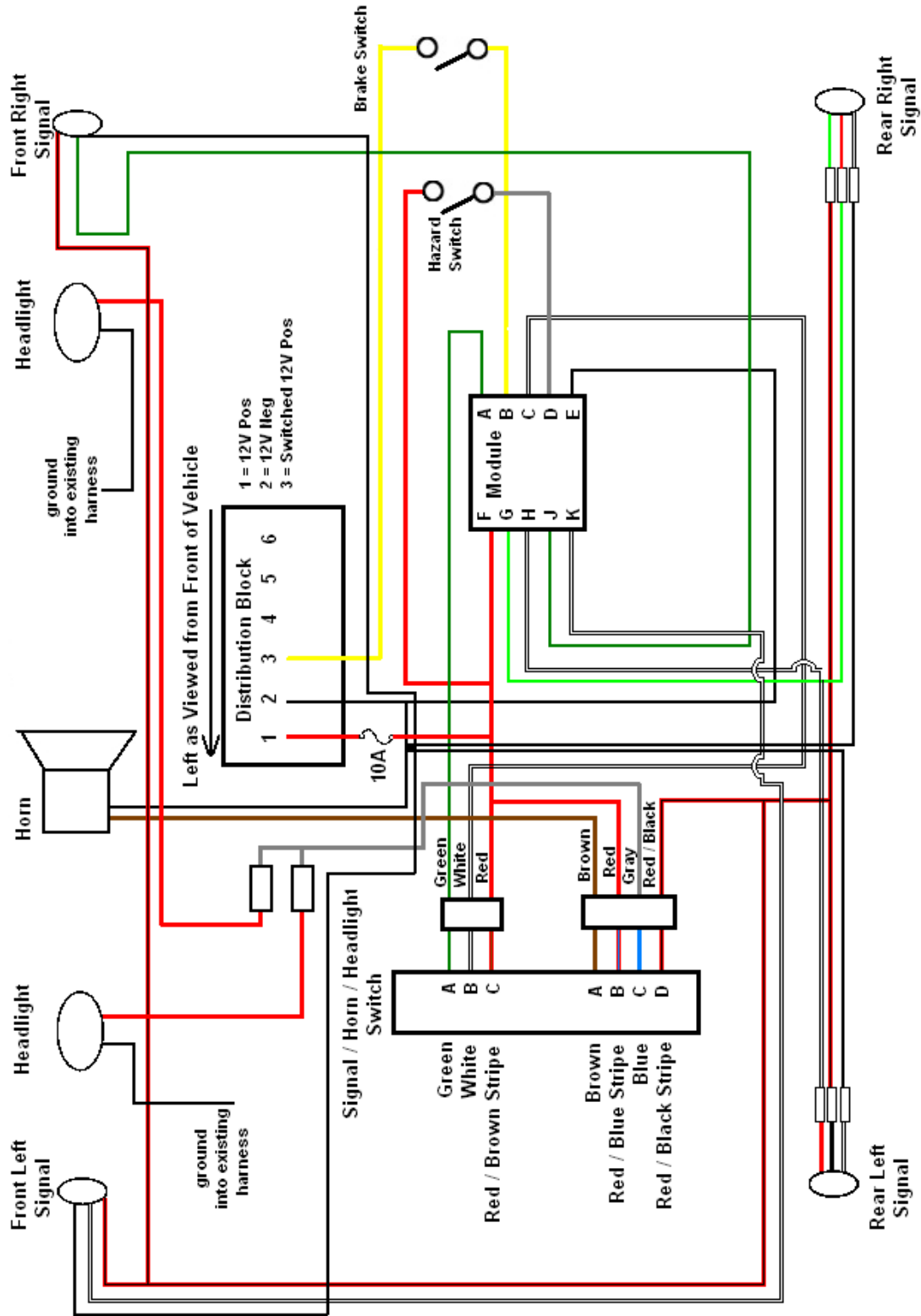

Note Wire Color Change @ Rear Lights on Early Models



LIMITED WARRANTY Utility Vehicles (UTVs)

American SportWorks (hereinafter referred to as "ASW"), hereby warrants to the original purchaser, that a new ASW UTV will be free from defects in material and workmanship. The period of warranty is one (1) year from date of purchase for the component parts (except as noted below) and two (2) years from the date of purchase for a Honda engine or three (years) from the date of purchase on a Subaru engine (engine warranties are covered by the engine manufacturer). Please refer to the engine manufactures warranty policy included with your ASW product.

ASW, if notified of a defect in material or workmanship during the period of warranty, will repair or replace, at its option, defective parts at no charge, other than the reasonable cost for the transportation of the component(s). ASW will also agree to pay reasonable charges for labor, if necessary, to perform a warranty repair.

The original purchaser must operate the vehicle and maintain the vehicle in accordance with the instructions provided in the Operator's Manual, the supplements hereto, and labels affixed to the vehicle.

General Exclusions: This limited warranty does not cover component failure or damage caused by any of the following: abnormal strain or stress, neglect; abuse; improper assembly of components which were supplied in the factory sealed carton after the vehicle left ASW; improper maintenance, improper use of the vehicle, including, but not limited to racing, jumping, stunt driving, or any other uses prohibited by the Operator's Manual. Additionally, this warranty does not cover component failure or damage to vehicles which are leased or rented, or vehicles which are used at a concession track.

Specific Exclusions: This limited warranty does not apply to components, which are subject to normal wear and tear. These items include, but are not limited to, the tires, brakes, throttle, shift, and brake cables, drive belt, the torque converter system, chain, seat, lights, fasteners, decals, or cosmetic body panels.

Warranty Service: To obtain warranty service you must return your ASW product to the local authorized dealer or service center, you must inform them of your warranty problem and provide proof of purchase before any warranty service is provided. The authorized dealer or service center will inspect the product to determine what warranty repairs or parts are needed and if the problem meets the requirements of ASW's Limited Warranty Policy. To locate the authorized dealer or service center nearest you please call ASW customer service at 866-646-5278 or 985-748-4889, or visit our website at www.amsportworks.com for more information.

ASW MAKES NO OTHER WARRANTY OF ANY KIND, EXPRESSED OR IMPLIED. ALL WARRANTIES OF MERCHANTABILITY AND FITNESS FOR A PARTICULAR PURPOSE WHICH EXCEED THE OBLIGATIONS AND TIME LIMITATIONS SPECIFIED IN THE WARRANTY ABOVE ARE HEREBY DISCLAIMED BY ASW AND EXCLUDED FROM THIS WARRANTY. ADDITIONALLY, THIS WARRANTY EXCLUDES ANY INCIDENTAL OR CONSEQUENTIAL DAMAGES, INCLUDING BUT NOT LIMITED TO LOSS OF USE. SOME STATES, PROVINCES OR COUNTRIES DO NOT ALLOW A MANUFACTURER TO EXCLUDE OR LIMIT INCIDENTAL OR CONSEQUENTIAL DAMAGES AND, THEREFORE, THE ABOVE EXCLUSION MAY NOT APPLY TO YOU.

SOME STATES, PROVINCES OR COUNTRIES DO NOT ALLOW LIMITATIONS ON HOW LONG AN IMPLIED WARRANTY WILL LAST; IT IS POSSIBLE THAT THE ABOVE LIMITATION MAY NOT APPLY TO YOU. THIS WARRANTY GIVES YOU SPECIFIC LEGAL RIGHTS, AND YOU MAY ALSO HAVE OTHER LEGAL RIGHTS, WHICH VARY, FROM STATE TO STATE PROVINCE TO PROVINCE OR COUNTRY TO COUNTRY.

American SportWorks LLC, P.O. Box 649, Roseland, LA 70456-0649 Phone 866-646-5278, Fax 985-748-4877

Service and Warranty

Special Note

Should your American SportWorks product require warranty repair, service or if you have any questions concerning assembly, replacement parts or how to care for your product please contact your local American SportWorks dealer or American SportWorks directly.

American SportWorks Dealer:

To locate the authorized dealer nearest you please call American SportWorks customer service at 1-800-643-7332 or (260)-432-1596, visit our website at www.amsportworks.com or contact your place of purchase.

Mail:

Customer Support
c/o American SportWorks LLC
4404 Engle Ridge Drive
Ft. Wayne, IN 46804

Telephone:

Customer Support
American SportWorks LLC
1-800-643-7332 or (260)-432-1596

Fax:

Customer Support
American SportWorks LLC
1-800-399-1399 (fax) or (260)-432-7870 (fax)

e-mail:

Customer Support
American SportWorks LLC



P.O. Box 649
 Roseland, LA 70456-0649
 (866)-646-5278 Phone
 (866)-329-5278 Fax
 www.amsportworks.com

UTILITY VEHICLE SET-UP, PRE DELIVERY CHECKLIST AND WARRANTY ACTIVATION

MODEL #	SERIAL #	DATE OF PURCHASE
---------	----------	------------------

DEALER SET-UP

<input type="checkbox"/> VISUALLY - inspect for damage	<input type="checkbox"/> WELDS - inspect for missing
<input type="checkbox"/> FASTENERS - inspect for missing bolts, nuts	<input type="checkbox"/> CLEAN UP - check clean up of unit
<input type="checkbox"/> CHECK ORDER - verify all items are as ordered	<input type="checkbox"/> DECALS - inspect for missing decals
<input type="checkbox"/> LOOSE COMPONENTS - verify all are there	
<input type="checkbox"/> OWNER MANUAL - verify all are there	

Set-up By:	Date:
-------------------	--------------

PRE-DELIVERY

<input type="checkbox"/> TIRES - adjust pressure to proper specification	<input type="checkbox"/> KEYS - verify operations of key switch
<input type="checkbox"/> WHEELS - check lug and axle nut for proper torque	<input type="checkbox"/> LIGHTS - verify proper operation of all lights
<input type="checkbox"/> CAGE - check to insure cage is assembled properly	<input type="checkbox"/> AXLE - inspect attachment and wheel bearings
<input type="checkbox"/> FASTENERS - check all fasteners for proper torque	<input type="checkbox"/> ENGINE - check engine RPM's for settings
<input type="checkbox"/> TRANSAXLE - insure oil level is correct	<input type="checkbox"/> SEAT RESTRAINTS - insure installed properly
<input type="checkbox"/> PARKING BRAKE - insure that working correctly	<input type="checkbox"/> SEATS - insure seat is installed properly
<input type="checkbox"/> DUMP BED - insure latch is adjusted properly	<input type="checkbox"/> GUARDS - inspect for missing bolts, nuts, guards
<input type="checkbox"/> SHIFT LEVER - insure working properly	<input type="checkbox"/> THROTTLE - insure throttle is working properly
<input type="checkbox"/> BRAKE - insure brake is adjusted and working	
<input type="checkbox"/> OIL - insure that engine oil level is correct	
<input type="checkbox"/> BATTERY - insure that it is fully charged	

Checked by:	Date:
--------------------	--------------

DEALER INFORMATION

Name:	Phone:
Address:	Fax:
City,St,Zip	E-mail:

CUSTOMER CHECKLIST

- VISUAL INSPECTION
 - RECEIVED SERVICE INSTRUCTIONS
 - SHOWN ALL ENGINE CONTROLS
 - WARRANTY EXPLAINED FULLY
 - RECEIVED OWNERS MANUAL
 - MY DEALER DEMONSTRATED ALL CONTROLS
 - RECEIVED KEYS & ENGINE MANUAL
 - I have visually inspected unit and found no defects.
- I understand that this product is designed for off road use only and is not intended for use on public roads or highways.
 - I have reviewed and understand the warranty policy.
 - I understand that before operating this vehicle all operators and passengers must read, follow and understands all safe operating instructions.
 - I understand this product is not designed for racing

CUSTOMER WARRANTY ACTIVATION / REGISTRATION INFORMATION

Name:	Phone:
Address:	Fax:
City,St,Zip	E-mail:
Signature:	Date:

TO ACTIVATE WARRANTY THIS FORM MUST BE RETURNED WITHIN TEN (10) DAYS

8-9-07

