



LED EM16-1100

Part #: EBMR16/450/GU5.3/LED Bulb Type: MR16



Product Description

Euri Lighting EM16-1100 replace conventional incandescent 25 watt bulbs by reducing energy consumption and providing a more natural and richer lighting experience. Its clean design extends durability providing constant bulb performance. Enjoy features such as instant turn on/ turn off capabilities, and mercury free exposure.



Estimated Energy Cost: \$.078 per year

Features



Instant-On/Off



Mercury Free



Energy Efficient

Dimensions

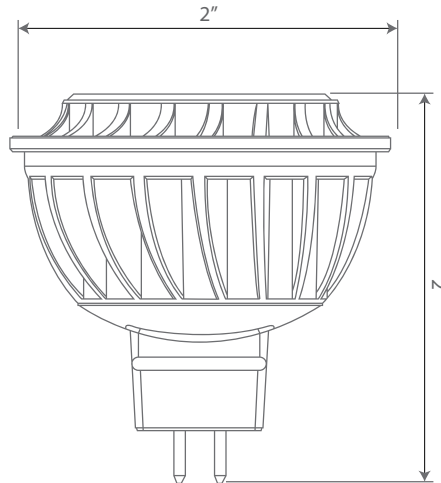

Photometric Data

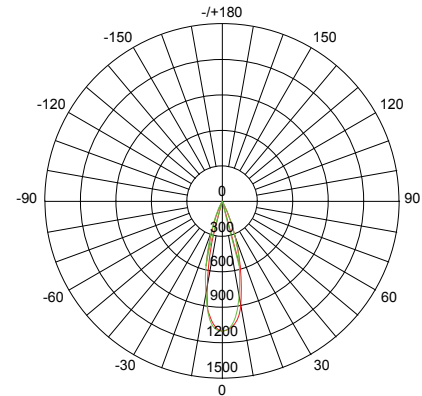

UNIT:cd

— C0/180, 12.7, 15.8

— C90/270, 15.1, 13.4

Specifications

Input Power	Input Voltage	Lumen Output	Beam Angle	Center Beam	CCT
6.5 W	12 V	450 lm	25°	1101 cd	3000 K
CRI	Luminous Efficacy	Power Factor	Input Current	Base	Lamp Lifespan
82	72 lm/W	0.7	0.8A	GU5.3	25000 Hrs.



Tel: 888-743-5766 (Toll Free) | Email: info@eurilighting.com | www.eurilighting.com

A Division of IRTtronix, Inc