

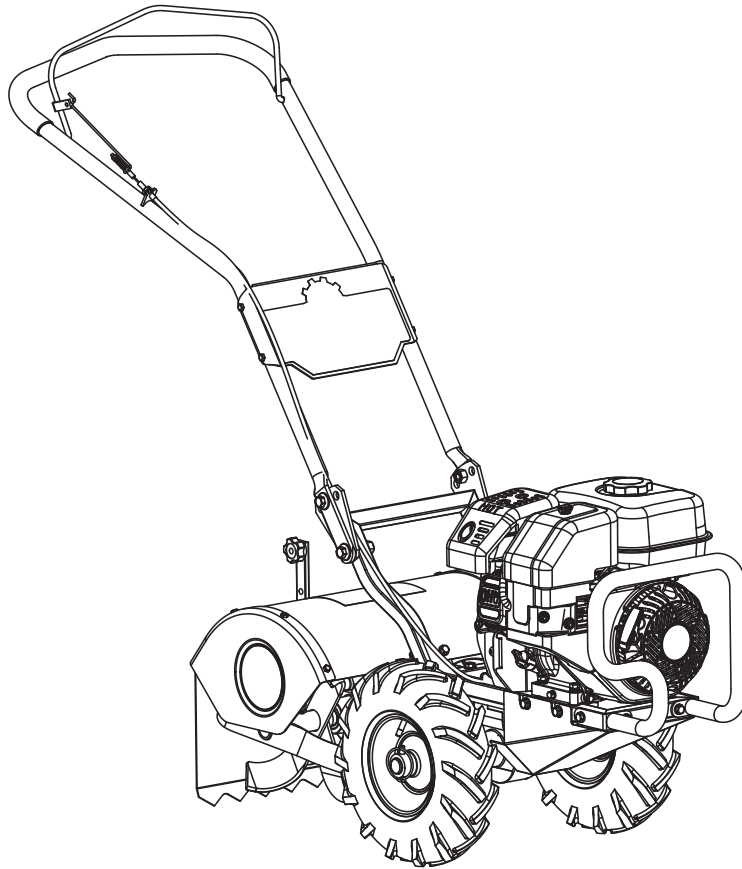

**DIRTY HAND
TOOLS**

Counter-Rotating Rear Tine Tiller



MODEL # 100983

Operation Manual



This safety alert symbol identifies important safety messages in this manual. Failure to follow this important safety information may result in serious injury or death.

Part # 101192 Rev C

Designed & Engineered in Colorado, USA



Assembled with Foreign & Domestic Components

For Service or Questions

Call 1-877-487-8275

720-287-5182

www.dirtyhandtools.com

Dirty Hand Tools® is a brand of



FrictionlessWorld

1100 W 120th Ave, Suite 600
Westminster, CO 80234 • 720-287-5182

Table of Contents

Important Safety Information

Intended Use	4
Personal Protective Equipment	4
General Safety	5
Safety Decals	6

Unpacking and Assembly Instructions

Unpacking	7
Attaching the Handlebar.....	8
Attaching the Wheels.....	9
Tiller Overview	10

Operating Precautions.....11

Operating Instructions

Preparation	12
Pre-Start Inspection	12
Startup.....	13
Shutting Down.....	13
Tilling.....	14
Depth Regulator Adjustment.....	15
Belt Tension Adjustment.....	15
Tilling Tips.....	15

Maintenance

Lubrication.....	16
Cleaning the Tine Axle Shaft.....	16
Changing the Forward/Reverse Belt	17
Engine Maintenance	18
Transmission Grease.....	18
Tire Pressure.....	18
Storage	19
Troubleshooting.....	20

Handlebar and Control Lever Parts List.....21

Motor Mount Parts List

Tines and Safety Shields Parts List

Warranty & Specifications

Back Cover

Important Safety Information



WARNING

WARNING: Read and thoroughly understand all instructions and safety information before assembling or operating this tiller. Failure to do so may cause serious injury or death. Do not allow anyone to operate this tiller who has not read this manual. As with all power equipment, a tiller can be dangerous if assembled or used improperly. Do not operate this tiller if you have doubts or questions concerning safe operation.

Call our customer service department at **720-287-5182**, **1-877-487-8275**, or visit www.dirtyhandtools.com if you have any questions or concerns about the safe operation of this equipment.



DANGER

Intended Use

Do Not Use the tiller for any purpose other than tilling garden soil for which it was designed. Any other use is unauthorized and may result in serious injury or death.

Personal Protective Equipment

When operating this tiller it is essential that you wear safety gear including goggles or safety glasses, steel toed shoes and tight fitting gloves (no loose cuffs or draw strings). Always wear ear plugs or sound deafening headphones to protect against hearing loss when operating this tiller. Always wear sturdy footwear. Never wear sandals, sneakers or open shoes, and never operate the tiller with bare feet. Do not wear loose clothing that might get caught in moving parts.



CAUTION

YOUR TILLER IS EQUIPPED WITH A SAFETY DEVICE THAT ENABLES YOU TO STOP THE WHEELS AND TINES QUICKLY IN AN EMERGENCY.

Learn how the drive safety control lever operates and how to control the tiller at all times.

Read the entire Operation Manual before using this equipment!



Important Safety Information

General Safety

Failure to follow warnings, cautions, assembly and operation instructions in the Operation Manual may result in serious injury or death.



DANGER

READ THE OPERATION MANUAL BEFORE OPERATION.

- **Do not** permit children to operate this equipment at any time. Do not permit others that have not read and understood the complete Operation Manual to operate this equipment.
- Keep all people and pets a minimum of 10 feet away from the work area when operating this tiller.
- **Do not** operate the tiller when under the influence of alcohol, drugs or medication.
- **Do not** allow a person who is tired or otherwise impaired or not completely alert to operate the tiller.



DANGER

CAREFULLY INSPECT THE AREA TO BE TILLED AND REMOVE ALL FOREIGN OBJECTS.

Do not till above underground water lines, gas lines, electric cables, or pipes. Do not operate the tiller in soil with large rocks and foreign objects which can damage the equipment.

- Leave control lever in the neutral position before starting the engine.
- Handle fuel with care; it is highly flammable. Use an approved fuel container. **Never add fuel to a running engine or hot engine.**
- Fill fuel tank outdoors with extreme care. **Never fill fuel tank indoors.**
- Replace gasoline cap securely and clean up spilled fuel before restarting.
- Never attempt to make any adjustments while the engine is running.

Important Safety Information

Safety Decals

Safety labels on the tiller are to remind you of important information while you are operating the unit. Make sure all safety warning decals are attached and in readable condition. Replace missing or defaced decals. Contact Dirty Hand Tools at 1-877-487-8275 for replacement decals.

⚠ WARNING

AVOID SERIOUS INJURY

- Read the Operator's Manual before operating.
- Know the location and function of all controls.
- Keep all shields and guards in place and in good condition while in operation.
- Never allow children to operate the tiller.
- Wear appropriate clothing and footwear.
- Never wear loose clothing that can become entangled in rotating parts.
- Wear protective goggles or eyewear.
- Wear protective noise reduction head gear.
- Carefully inspect the area to be tilled. Remove rocks and other obstacles.
- Check for underground utility lines including electrical, water, gas and other pipes before beginning operation.
- **STOP THE ENGINE AND DISCONNECT THE SPARK PLUG WIRE BEFORE REMOVING DEBRIS OR SERVICING.**
- **SHUT THE ENGINE OFF WHEN LEAVING THE TILLER FOR ANY REASON.**
- **WAIT FOR ALL MOVING PARTS TO STOP.**

101027

⚠ WARNING

WHEELS ACT AS BRAKES

- Never start or operate the tiller with the wheels in the Free-Wheel position. Make sure wheel lockouts are engaged through wheel hubs and axle.
- Wheels act as brakes to keep the tiller at a controlled speed. Disengage wheel lockouts **ONLY** when the engine has stopped.

OPERATION

REFER TO OPERATOR'S MANUAL FOR DETAILED OPERATION AND SAFETY INSTRUCTIONS

TO START:

1. Move drive control lever to neutral position.
2. Lower the drag stake so that the tines do not touch the ground.
3. Check position of wheels and wheel lockouts.
4. Slide choke control to choke position.
5. Move throttle control lever to the fast position.
6. Pull starter rope.

101027

⚠ DANGER

AVOID INJURY FROM ROTATING TINES!



KEEP HANDS, FEET AND CLOTHING AWAY!

- Tines and wheels rotate when drive control lever is pulled toward the handle bar.
- Releasing the drive control lever stops the wheels and tines from rotating.

101026

⚠ WARNING

DO NOT START ENGINE UNLESS THE BELT COVER IS ATTACHED TO THE TILLER.

KEEP HANDS, FEET AND CLOTHING AWAY FROM MOVING BELTS AND PULLEYS. FAILURE TO COMPLY COULD RESULT IN SERIOUS INJURY.

SEE OWNER'S MANUAL FOR COMPLETE OPERATING AND SAFETY INSTRUCTIONS.

101028



101029

Unpacking and Assembly

Your tiller comes partially assembled at the factory. The following instructions will help you unpack your tiller, assemble and adjust the depth regulator lever, cable tension and handlebar height. You will need 2- 9/16" wrenches.

Unpacking

Open top of carton and remove handlebar assembly.

Find parts packet. Parts packet contains:

2 each - Flanged Hex Bolt, M12 x 50

2 each - Flanged Hex Bolt, M12 x 25

4 each - Nylock Hex Nut, M12

4 each - Hex Bolt, M6 x 35

4 each - Nylock Hex Nut, M6

2 each - Lynch Pin, 5/16" x 1-3/4"

1 each - Detent Pin, 5/16" x 2"

Do not attempt to lift the tiller from the carton. Cut open end of carton and remove machine by putting wheels onto machine with lock pin disengaged from wheel. Then toll the tiller from carton.

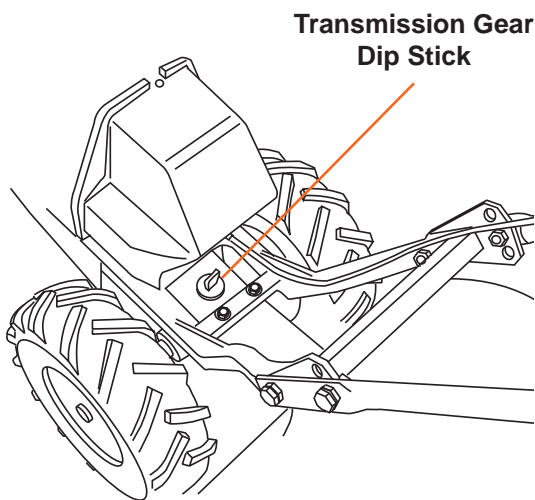

Figure 1



CAUTION

DO NOT ADD ENGINE OIL TO THE TRANSMISSION GEAR CASE

Only Liquid Grease should be used when needed.

The tiller transmission is filled at the factory with the correct amount of liquid grease (see Figure 1).



CAUTION

DO NOT ATTEMPT TO START ENGINE BEFORE ADDING OIL TO ENGINE

The engine is shipped from the factory without oil. You must add engine oil before starting the engine. Use only the recommended weight of oil for a 4-cycle engine (See Engine Operation Manual).

1. Attaching the Handlebar

1. Place the handlebar plate ① on outside of upper handlebar assembly ②, align holes, and attach with Hex Bolts, M6 x 35 ③ and Hex Nuts, M6 Nylock ④ in 4 places.
2. Position the upper handlebar assembly ② to align with one of the three sets of holes on the Tiller Frame ⑤ and attach with Hex Bolt, M12 x 25 ⑥ on top and Hex Bolt, M12 x 50 ⑦ on the bottom side with Hex Nuts, M12 Nylock ⑧ in four places.
3. Tighten all hardware securely.

NOTE: The three different positions for attachment to the lower handlebar assembly allow for height adjustment.

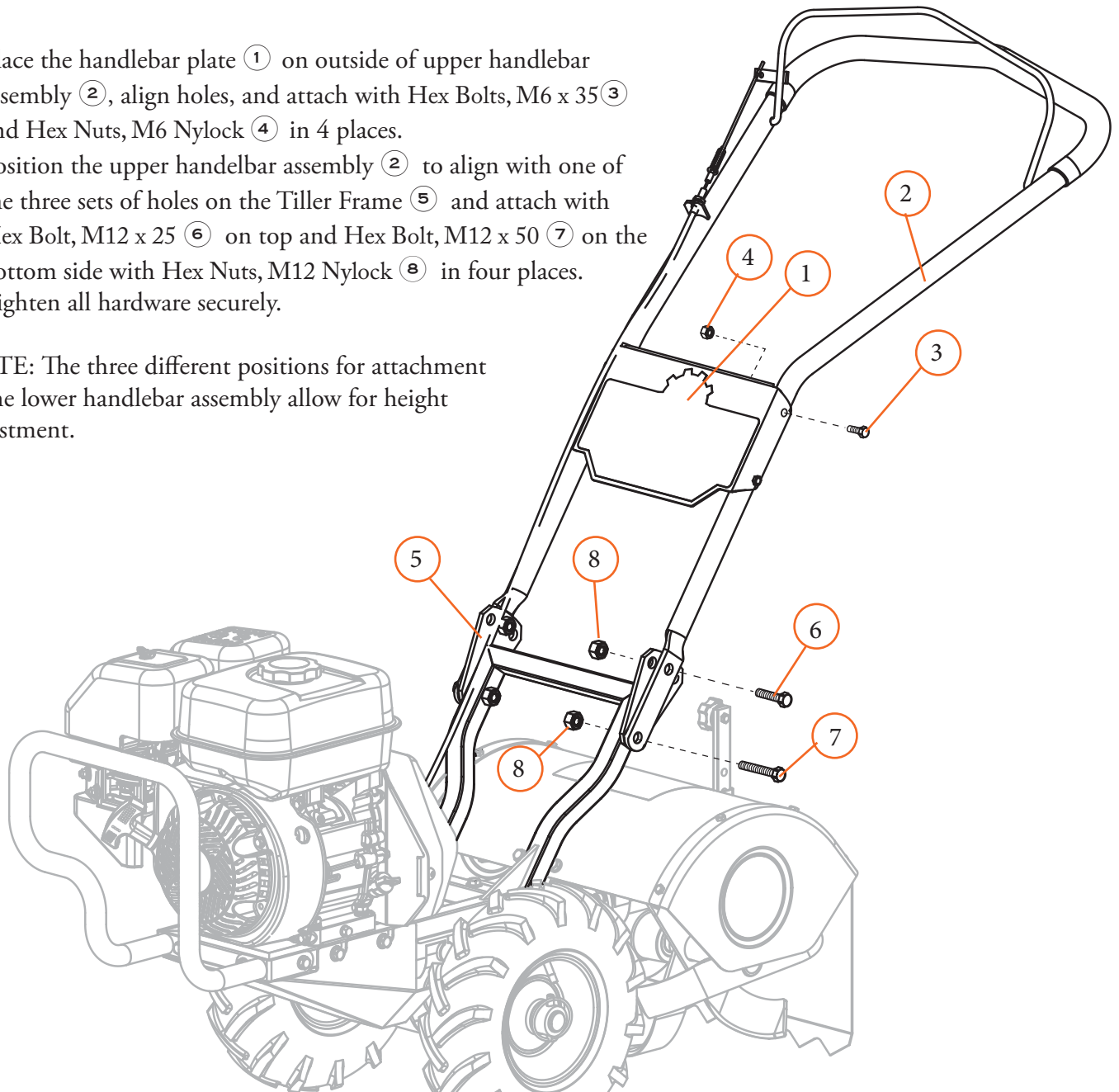

Item #	Part #	Description	Qty.
1	101728	Handlebar Plate	1
2	100926	Upper Handlebar Assembly	1
3	101713	Hex Bolts, M6 x 35	4
4	101494	Hex Nuts, M6 Nylock	4
5	101080	Tiller Frame	1
6	100953	Hex Bolt, M12 x 25	2
7	100954	Hex Bolt, M12 x 50	2
8	100059	Hex Nuts, M12 Nylock	4

2. Attaching the Wheels

To place wheels in tilling position. (See Figure)

1. Slide wheel ① onto axle.
2. Align hole in axle with hole in wheel hub.
3. Insert lynch pin ② through holes, fold lock pin ring to secure pin.
4. Firmly lock wheel and axle together before tilling.
4. Repeat for other wheel.

NOTE: Always have both wheel lock pins in or out. Do not operate tiller with only one wheel locked.

To place wheels in free-wheel position.

1. Remove lynch pin. Slide wheel inward toward machine.
2. Insert pin in axle only.
3. Wheel should turn freely on axle.



WARNING

NEVER START ENGINE OR OPERATE TILLER WITH WHEELS IN FREE-WHEEL POSITION.

The free-wheel position is for transporting the tiller long distances over level ground-do not attempt to move the tiller up or down steep grades in the free-wheel position.

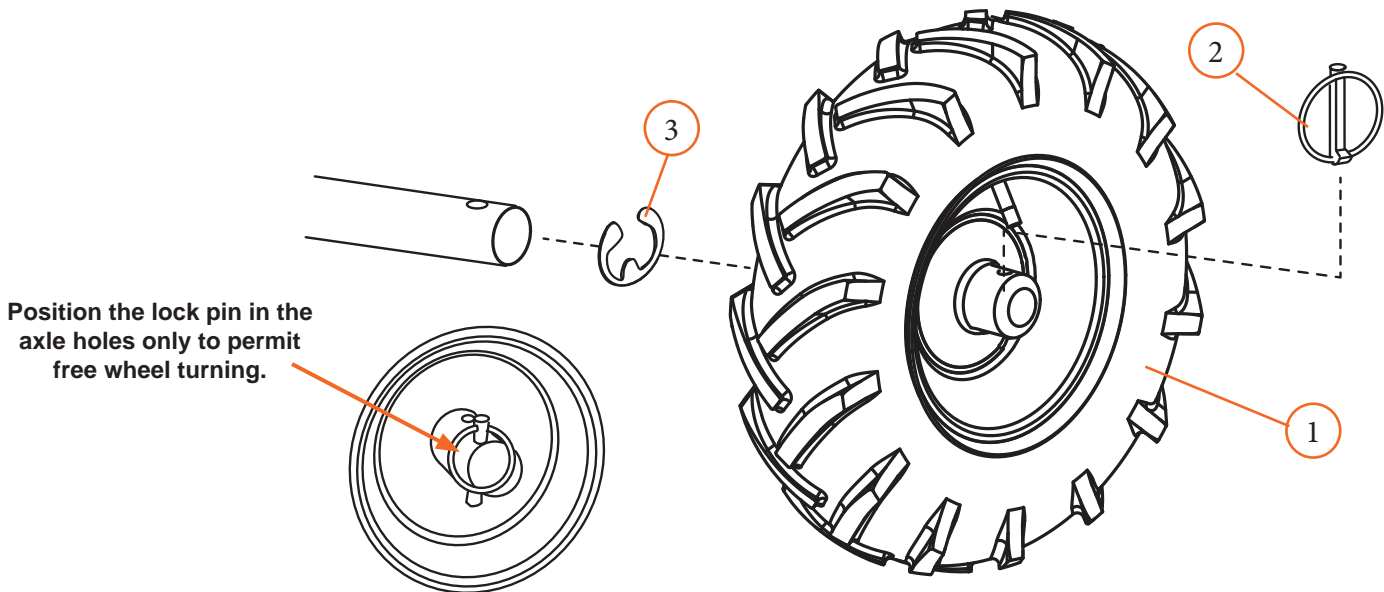

Item #	Part #	Description	Qty.
1	100879	Wheel, Right 13 x 5-6	1
	100907	Wheel, Left 13 x 5-6	1
2	101221	Lynch Pin, 5/16" x 1-3/4"	2
3	100884	Retaining Ring, 1"	2

Tiller Overview

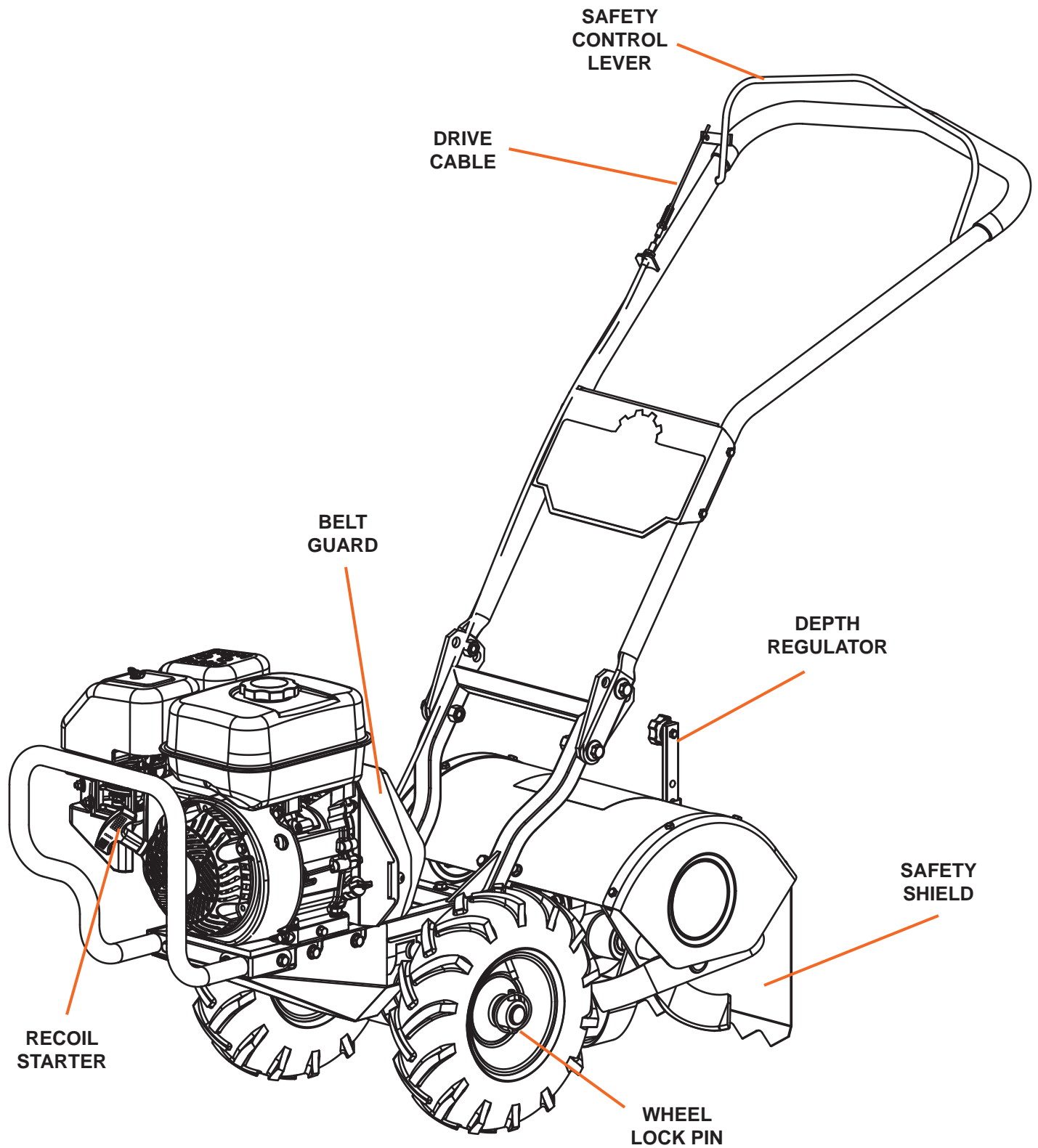

Operating Precautions



CAUTION

READ, UNDERSTAND AND FOLLOW ALL OF THE PRECAUTIONS BELOW.

Always perform the pre-start checklist before starting the engine.

- **Never** operate the tiller without safety guards and covers in place.
- **Never** start the engine or operate the tiller with the wheels in the free-wheel position. Make sure the wheel lock pins are engaged through the wheel hubs and wheel axle. The wheels act as a brake to keep the tiller at a controlled speed. Disengage wheel lock pins to permit free-wheeling only when engine is stopped.
- **Keep hands, feet, and clothing away from rotating parts. Keep clear of tiller tines at all times.**
- Tines and wheels rotate when tiller is engaged in forward, tines and wheels rotate when the drive safety control lever, is pulled toward the handlebar. *Releasing the drive safety control lever to the neutral position stops the wheels and tines.*
- **Use extreme caution** when operating on or crossing gravel drives, walks, or roads. Stay alert for hidden hazards or traffic.
- After striking an obstacle, **stop the engine**, remove the wire from the spark plug, inspect the tiller for damage and repair before restarting.
- If tines become clogged, **stop the engine** and **disconnect the spark plug wire** before removing any obstruction.
- **Engine muffler will be hot** from operation. Do not touch it with bare skin or a severe burn may result.
- If the unit should start to vibrate abnormally, stop the engine and check immediately for the cause. *Vibration is a problem warning.*
- **Do not** run the engine indoors; exhaust fumes are deadly.
- **Do not** overload the tiller by trying to till too deep or too fast.
- **Never** operate the machine at high transport speeds on slippery surfaces. Look behind and use care when backing.
- Use only attachments and accessories approved by the manufacturer.
- **Never** operate the tiller without good visibility or adequate light.
- Be careful when tilling in hard ground. The tines may catch in the ground and propel the tiller backwards. *If this occurs, let go of the handlebars and do not restrain the machine.*
- **Take precautions when leaving the machine unattended.** Disengage all control levers, stop the engine, wait for all moving parts to stop, and make certain guards and shields are in place.
- **Shut off the engine when leaving the operating position** for any reason. Wait for all moving parts to stop.

Operating Instructions

Preparation for Operation

Fill Engine Crankcase with Oil

1. Add oil according to engine manual. Do not overfill. Use a clean, high quality detergent oil. Use no special additives with recommended oils. **Do not mix oil with gasoline.** Oil level must be full. Check the oil level by removing oil fill plug. Oil level should be up to the bottom of the fill plug opening.
2. Always check oil level before starting engine. Refer to engine manual for capacity and type of oil to use.

Pre-Start Inspection

1. Make sure safety shields are in place and nuts & bolts are secure.
2. Check oil level in engine crankcase. See your engine manual for procedure and specifications.
3. Inspect air cleaner for cleanliness.
4. Check the fuel supply. Fill the fuel tank no closer than 1 inch from top of tank to provide space for expansion. See your engine manual for fuel recommendations.
5. Be sure spark plug wire is attached and spark plug is tightened securely.
6. Check position of wheels and wheel lock pins.
7. Check depth regulator lever position.
8. Examine underneath and around engine for oil or fuel leaks.
9. Inspect fuel hoses for tightness and fuel seepage.
10. Look for signs of engine damage.
11. Remove excessive debris from muffler area and recoil starter.



WARNING

WHEELS MUST ALWAYS BE LOCKED IN THE TILLING POSITION WHEN ENGINE IS RUNNING.

Do not operate the tiller with the wheel lockouts unlocked. Always set the wheels in tilling position before starting engine. Always put the depth regulator lever in the transport position before starting engine. Tines should clear the ground.

Operating Instructions



NEVER START ENGINE OR OPERATE TILLER WITH WHEELS IN FREE-WHEEL POSITION.

The free-wheel position is for transporting the tiller long distances.

Start-Up

The controls required to start and run the tiller are located on the engine and are marked “Choke” and “Throttle”. A detailed description of engine operation and precautions is available in the engine operation manual.

Cold Starts

1. Move choke lever to full choke position.
2. Move throttle lever to “start”.
3. Pull starting rope out slowly one time and allow to return normally.
4. Pull starting rope out rapidly, and allow rope to return normally.
5. When engine starts, gradually move choke lever to “no choke” position and increase throttle speed.

Restarting A Warm Engine

Restarting an engine that is already warm from previous running does not normally require use of the choke.

1. Move throttle lever to “start” position.
2. Pull starting rope out rapidly until engine starts. Allow rope to return normally. Repeat until engine starts.
3. Adjust throttle speed to “high” for best tiller action.

Idle Speed

Use the “low” position on the throttle lever to reduce stress on the engine when tilling is not being performed. Lowering the engine speed to “idle” will help extend the life of the motor, as well as conserve fuel and reduce the noise level of the equipment.

Operating Speed

For normal tilling, set the throttle lever to “fast”.

Shutting Down

To stop the engine at any time, move throttle control to the off position. To stop wheels and tines at any time, release drive safety control levers to neutral position.

Operating Instructions



WARNING

PRACTICE OPERATING THE CONTROLS AND USING THE TILLER WITH TINES OUT OF GROUND BEFORE BEGINNING TO TILL.

It is important that you know how to use the tiller properly, keep control at all times, stop the tines and wheels from turning, and stop the engine if necessary.

Read the entire Operation Manual before using the equipment!

Tilling

1. Adjust depth regulator lever to desired tilling depth. (See page 15)

Note: Raise depth regulator lever up one hole at a time, testing tiller operation after each raise. Raising depth regulator lever too high can result in loss of control of tiller!

2. Move the throttle control to fast.
3. Place the tiller in forward by pushing down on the drive safety control lever-this will engage the wheels and tines.

Note: You can slow the tiller's forward advance at any time by putting slight downward pressure on the handlebars. You can stop the tiller by releasing the drive safety control levers to the neutral position.

Drive Safety Control Lever

Pulling the drive safety control lever toward the handlebar engages the wheels and tines. **Releasing the lever stops the wheels and tines and brings the tiller to a complete stop** (see Figure 2).

Pulling the safety control lever towards the handlebar engages both the wheels and tines.

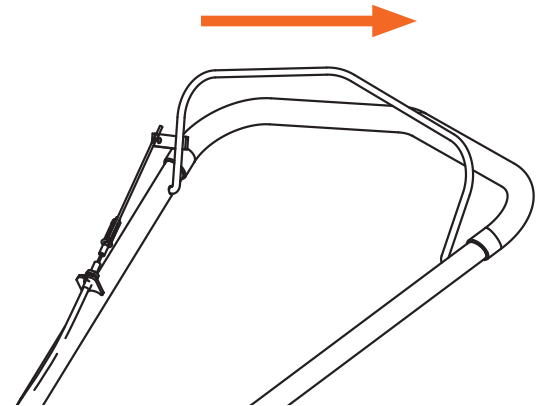

Figure 2

Operating Instructions

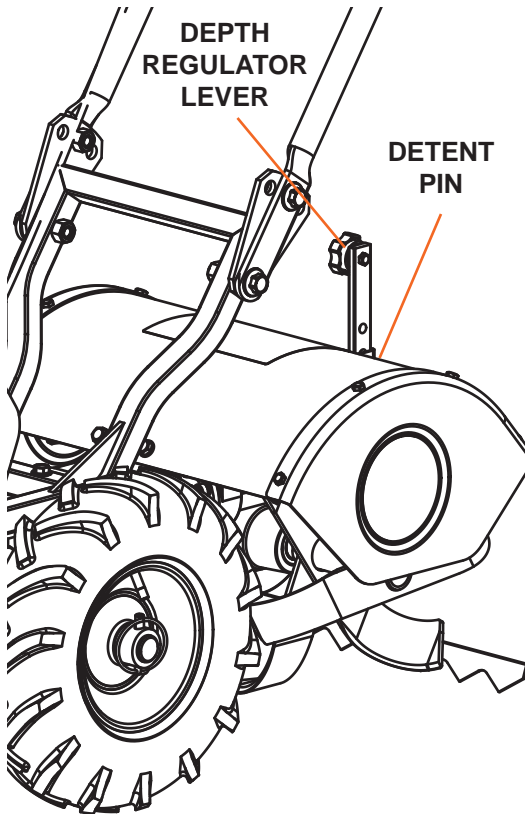

Figure 3

Depth Regulator Adjustment

Tilling depth is controlled by the height of the depth regulator lever. To adjust tilling depth (see Figure 3).

1. Remove detent pin.
2. Raise the depth regulator lever to position tines at chosen tilling depth.
3. Align hole in depth regulator lever with hole in depth regulator bracket and replace detent pin.

Depth Regulator Lever Down = Shallower tilling. Place the detent pin in the top hole of the depth regulator lever for shallowest tilling. Depth Regulator Lever Up = Deeper tilling. Place the detent pin in the bottom hole of the depth regulator lever for deepest tilling.

Belt Tension Adjustment

Proper belt tension is critical to good performance. After 1/2 hour of operation, all cables may have to be adjusted due to initial stretch. Thereafter, check tension after every 2 hours of operation.

To increase belt tension (see Figure 4):

1. Loosen upper jam nut. Turn nut up cable in 1/8" increments.
2. Tighten lower jam nut.
3. Check adjustment.

This procedure can be repeated until conduit adjustment bolts are fully adjusted. If no more adjustment can be made, belt may have to be replaced.

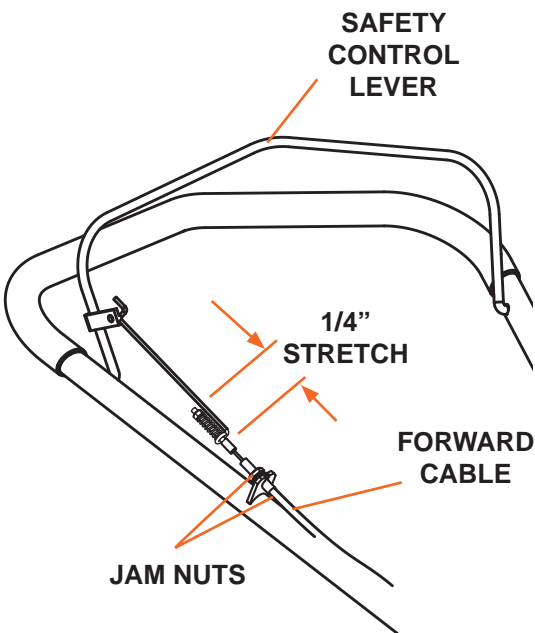

Figure 4

Tilling Tips

The key to successful tilling is to begin with a shallow cut on the first pass, and then work an inch or two deeper on each successive pass.

- Tilling depth will vary with ground conditions.
- When beginning to till in unbroken ground or in extremely hard soil, set the detent pin in the highest hole of the drag stake. This will allow for shallow tilling. With the drag stake in this position, make several light passes over the area to be tilled. Reset for deeper depths with successive passes.
- If tiller jumps or skids uncontrollably, lower the drag stake by placing the detent pin in a higher hole. This will allow for shallower tilling. Hold firmly to the handlebars to control sudden lurches.

Immediately release the drive control lever if the tines jam or you strike a foreign object. With drive control lever in neutral position, push throttle control to stop position to stop the engine. Disengage the spark plug wire. When tines have stopped, remove foreign objects and check for damage.



WARNING

THE TILLER TRANSMISSION IS SHIPPED FROM FACTORY WITH THE CORRECT AMOUNT OF LIQUID GREASE.

- Keep tiller, safety shields and covers, attachments, and accessories in safe working condition.
- Check shear bolts, engine mounting bolts, and other bolts at frequent intervals for proper tightness to be sure the equipment is in safe working condition.
- To prevent accidental starting, always disconnect and secure the spark plug wire from the spark plug before performing tiller maintenance.
- Never run the engine indoors. Exhaust fumes are toxic.
- Always allow muffler to cool before filling fuel tank.
- Never store equipment with gasoline in the tank inside of a closed building where fumes may reach an open flame or spark. Allow the engine to cool before storing in any building.
- Always refer to the operator's guide instructions for important details if the tiller is to be stored for an extended period.
- Add a fuel stabilizer to gas tank and run for 10-15 minutes to prevent fuel from gumming up during an extended storage period.

Lubrication

Proper lubrication of moving mechanical parts is critical for proper care and maintenance. Oil the moving parts at 10 hour intervals using a 30 weight oil.

Cleaning the Tine Axle Shaft

1. Turn off engine. Engine must be cool.
2. Remove spark plug wire and secure from spark plug.
3. Tip the tiller forward. Block the tiller in position so that it rests on the engine mount and the tines are exposed.
4. Remove all vegetation, string, wire, and other material that may have accumulated on the axle between the inside set of tines and the seal on the transmission housing.
5. Tip the tiller back to a level position.
6. Replace spark plug wire.

Maintenance

Changing the Forward/Reverse Belt

1. Turn off engine. Engine must be cool.
2. Remove spark plug wire and secure from spark plug.
3. Remove belt guard (see Figure 5).
 - Remove the forward belt from the forward engine pulley.
 - Gently pull the engine recoil rope to rotate the pulley.
 - With the pulley turning, force the forward belt out of the V-groove.
 - Slide the belt free of the engine pulley.
 - Pull the forward belt down and out of the way.
4. Install new forward belt:
 - Place forward belt in transmission pulley groove.
 - Gently pull the engine recoil rope to rotate the pulley while forcing the forward belt into the V-groove.
5. Re-attach belt guard.
6. Attach spark plug wire.

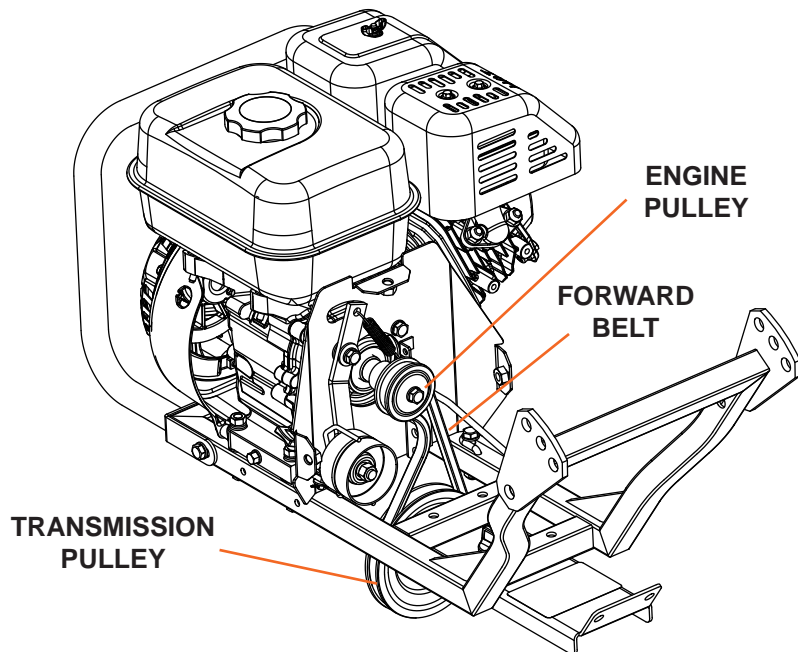

Figure 5



WARNING

TURN OFF ENGINE AND DETACH SPARK PLUG WIRE. ENGINE MUST BE COOL.

Engine Maintenance

Refer to the engine manual included in your parts packet for information on engine maintenance. Your engine manual provides detailed information and a schedule for performing the following:

1. Check oil level before each use and after 8 hours of operation.
2. Change oil after first 5-8 hours of operation. Change oil while engine is warm. Refill with new oil of recommended grade.
4. Check spark plug yearly or every 100 hours of operation.
5. Service air cleaner.
6. Keep engine and parts clean.
7. Check engine and equipment often for loose nuts and bolts.

Check or Fill Engine Crankcase

1. Add oil according to engine manual. Do not overfill. Use a clean, high quality detergent oil. Use no special additives with recommended oils. **Do not mix oil with gasoline.** Oil level must be full. Check the oil level by removing oil fill plug. Oil level should be up to the bottom of the fill plug opening.
2. Always check oil level before starting engine. Refer to engine manual for capacity and type of oil to use.

Check Tiller Transmission Grease

Note: Transmission grease does not have to be changed unless contaminated with dirt, sand, metal or other foreign debris.

Check the grease level annually. To check the grease level:

1. Move tiller to level ground.
2. Remove grease level dipstick located between the handlebar mounts on the engine mount. Correct grease level is indicated by presence of grease on the dipstick. If dipstick is dry, refill with Mobilux EP1 or equivalent transmission grease.
3. Replace grease level dipstick in the filler hole.
4. Note that the front wheel transmission and rear tine transmission are one common reservoir. When you add to the front transmission, you must wait a short period of time for the grease to flow rearward and equalize in both front and rear. The dipstick will read correctly on level ground for both gear units. (Use Mobilux EP1 or equivalent, transmission grease)

Check Tire Pressure

Recommended tire pressure is 20 PSI. If tires do not have equal pressure, tiller will pull to one side.

Storage



WARNING

DO NOT STORE TILLER IN UNVENTILATED AREA

where fuel fumes may reach flame, sparks, pilot lights or other ignition source.

Drain fuel outdoors away from any ignition sources.

Use only approved fuel containers.

Prepare for Storage

Follow the steps below to prepare your tiller for storage. Read your engine manual for detailed instructions on preparing the engine for storage.

1. Protect wheels and axles from rust: Remove lock pin and slide wheel off hub. Coat the axles lightly with axle grease. Slide wheel back on hub and insert lock pin.
2. Drain fuel system completely following engine manufacturer's instructions or add fuel stabilizer to prevent fuel from gumming up during extended storage period.
3. While engine is still warm, drain the oil from the engine. Refill with fresh oil of the recommended grade.
4. Clean external surfaces, engine and cooling fan.
5. Remove spark plug, pour one ounce of SAE 30 oil into spark plug hole.
6. Plug hole and pull starter cord slowly to distribute oil evenly in cylinder head area.
7. Reinstall spark plug.
8. Transport unit to a suitable storage location. If you have chosen to use a fuel stabilizer and have not drained the fuel system, follow all safety instructions storage precautions in this manual to prevent the possibility of fire from the ignition of gasoline fumes. Remember, gasoline fumes can travel to distant sources of ignition and ignite, causing risk of explosion and fire.
9. If there is any possibility of unauthorized use or tampering, remove the spark plug and store it in a safe place before storing the tiller unit. Be sure to plug the spark plug hole to prevent foreign material from entering.

Troubleshooting

PROBLEM	SOLUTION
Engine will not start	<ul style="list-style-type: none"> • Add gas to gas tank. • Connect spark plug wire to spark plug • Throttle must be positioned at choke for a cold start
Engine runs rough, floods during operation	<ul style="list-style-type: none"> • Clean or replace air cleaner
Engine is hard to start	<ul style="list-style-type: none"> • Drain old fuel and replace with fresh. Use gas stabilizer at end of season • Make sure spark plug wire is securely attached to spark plug • Drive safety control levers must be released to neutral position to start the engine
Engine misses or lacks power	<ul style="list-style-type: none"> • Raise the tines for shallow tilling by lowering the depth regulator lever • Remove and clean fuel tank • Clean or replace air cleaner • Improper carburetor adjustment, take to authorized engine service center • Replace spark plug and adjust gap • Drain and refill gas tank and carburetor
Engine will not stop when throttle control is positioned at stop	<ul style="list-style-type: none"> • See engine manual to check and adjust the throttle linkage
Tiller moves forward during starting	<ul style="list-style-type: none"> • Drive safety control levers must be released to neutral position to start the engine
Tiller is difficult to control when tilling (machine jumps or lurches forward)	<ul style="list-style-type: none"> • Lock wheels in tilling position • Raise the tines for shallower tilling by lowering the depth regulator lever
Tines turn, wheels do not turn	<ul style="list-style-type: none"> • Lock wheels in tilling position • Internal transmission failure, see your dealer
Tines turn, wheels turn, tiller does not move	<ul style="list-style-type: none"> • Lower the tines for deeper tilling by raising the depth regulator lever
Belt squeals when in neutral position	<ul style="list-style-type: none"> • Adjust forward belt guide by turning engine off and allow muffler to cool. Disconnect spark plug wire and secure. Remove belt guard. Pull down on drive safety control lever and manually bend forward belt guide so there is 1/16" or less clearance between belt guide and belt. Replace belt guard and spark plug wire.
Excessive heat build up in transmission/tine area during tilling	<ul style="list-style-type: none"> • Clean the Tine Axle Shaft (See Page 16) • Check transmission fluid and fill if needed

Handlebar and Control Lever Parts List

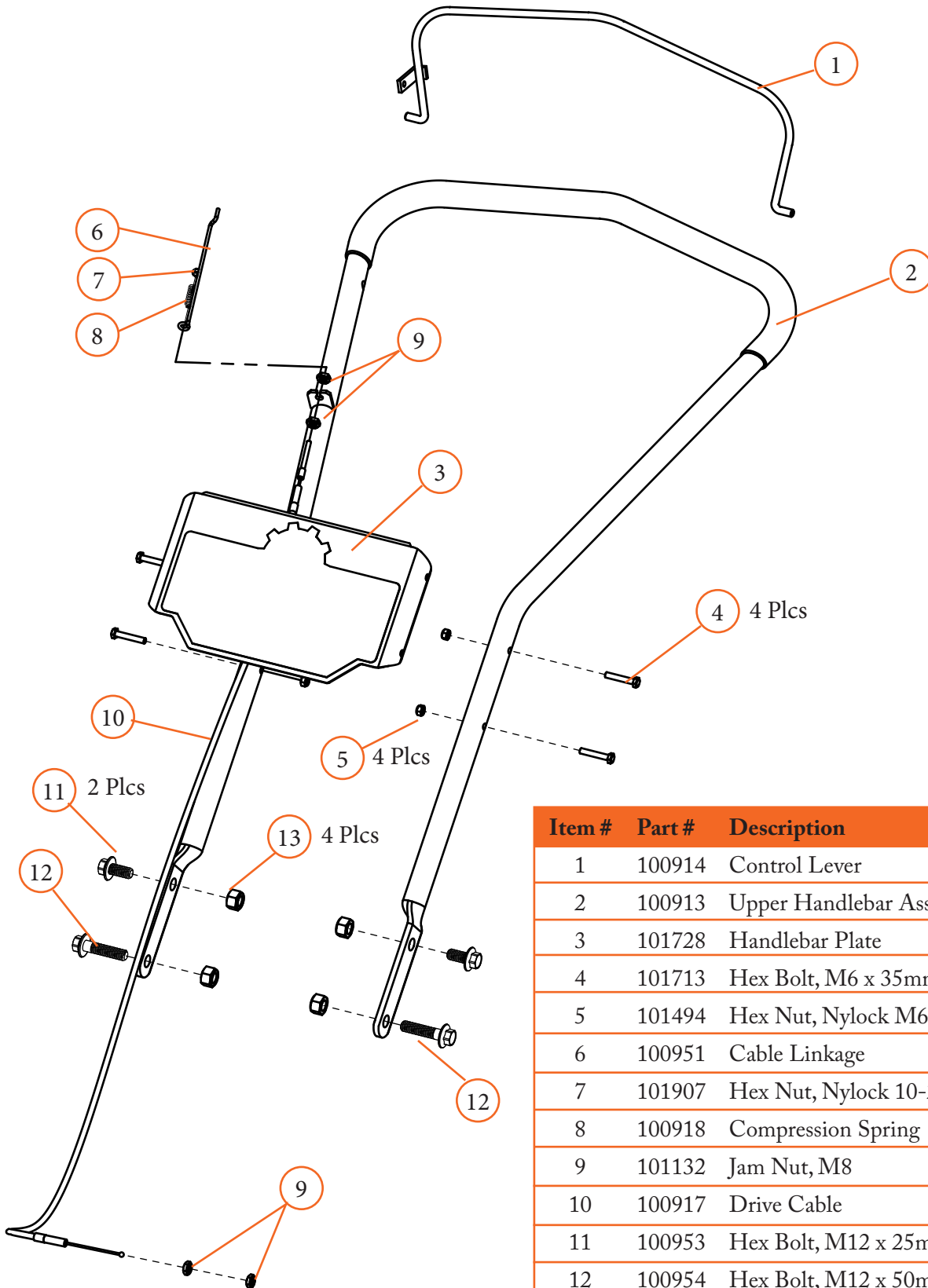

Item #	Part #	Description	Qty.
1	100914	Control Lever	1
2	100913	Upper Handlebar Assembly	1
3	101728	Handlebar Plate	1
4	101713	Hex Bolt, M6 x 35mm	4
5	101494	Hex Nut, Nylock M6	4
6	100951	Cable Linkage	1
7	101907	Hex Nut, Nylock 10-24	1
8	100918	Compression Spring	1
9	101132	Jam Nut, M8	4
10	100917	Drive Cable	1
11	100953	Hex Bolt, M12 x 25mm	2
12	100954	Hex Bolt, M12 x 50mm	2
13	100059	Hex Nut, Nylock M12	4

Motor Mount Parts List

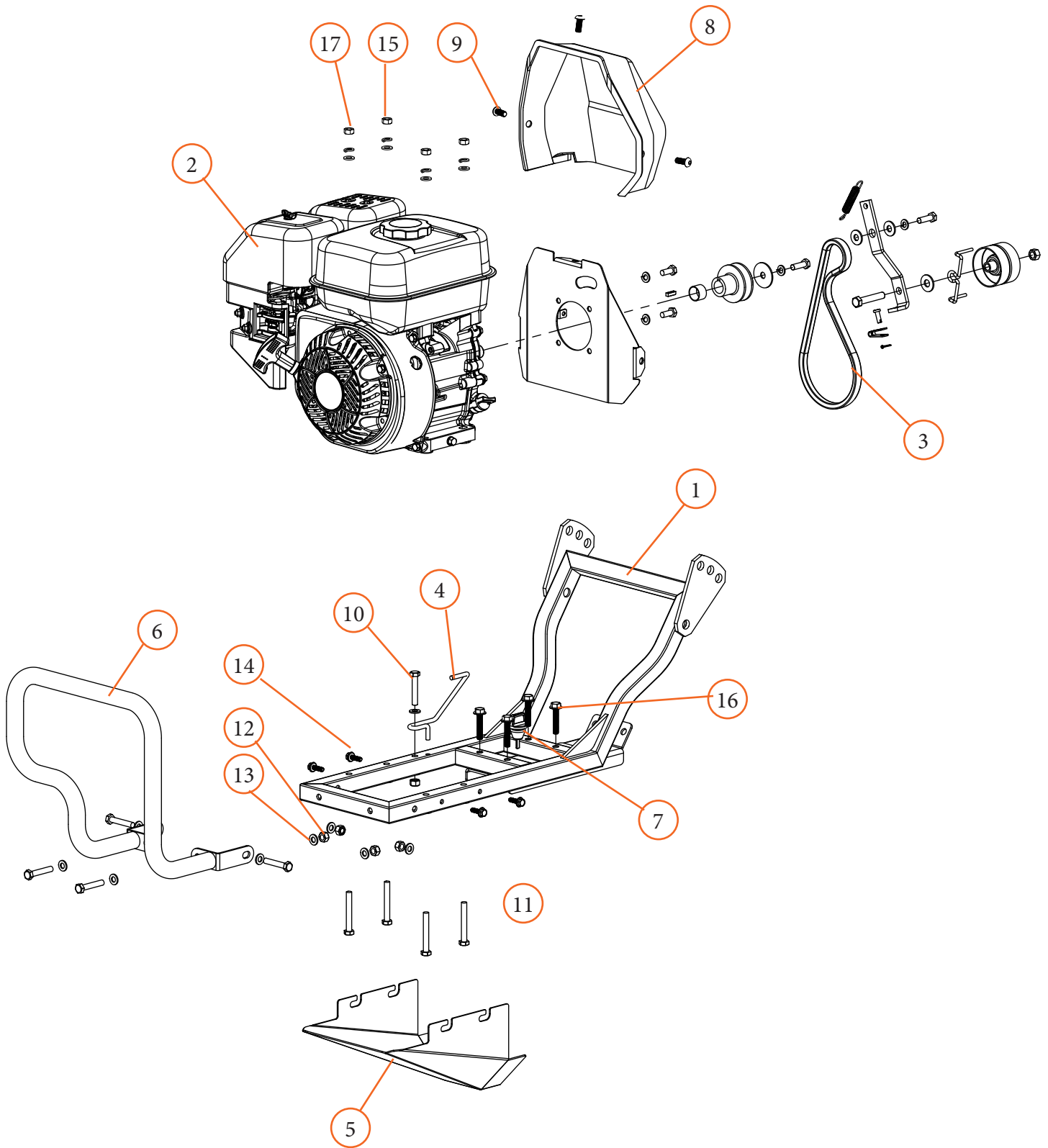

Motor Mount Parts List

Item #	Part #	Description	Qty.
1	101080	Tiller Frame Assembly	1
2	100972	Engine Assembly with Pulleys	1
3	100978	V-Belt, Transmission	1
4	100956	Belt Guide Rod	
5	101719	Lower Belt Shield	1
6	100906	Engine Guard	1
7	100977	Gearbox Dip Stick	1
8	101180	Pulley Shield	1
9	101708	Button Head Bolt, M8 x 1.25 x 20mm	3
10	100129	Hex Bolt, M8 x 1.25 x 45mm, G8.8	5
11	100837	Hex Bolt, M8 x 1.25 x 60mm, G8.8	4
12	100128	Hex Nut, Nylock, M8 x 1.25, G8.8	5
13	100130	Flat Washer, M8	18
14	101536	Hex Bolt M6 x 1.0 x 20mm, G8.8	4
15	100579	Hex Nut, M8 x 1.25	4
16	100955	Hex Bolt, M8 x 1.25 x 40mm, G8.8	4
17	100127	Lock Washer, M8	4

Tines and Safety Shields Parts List

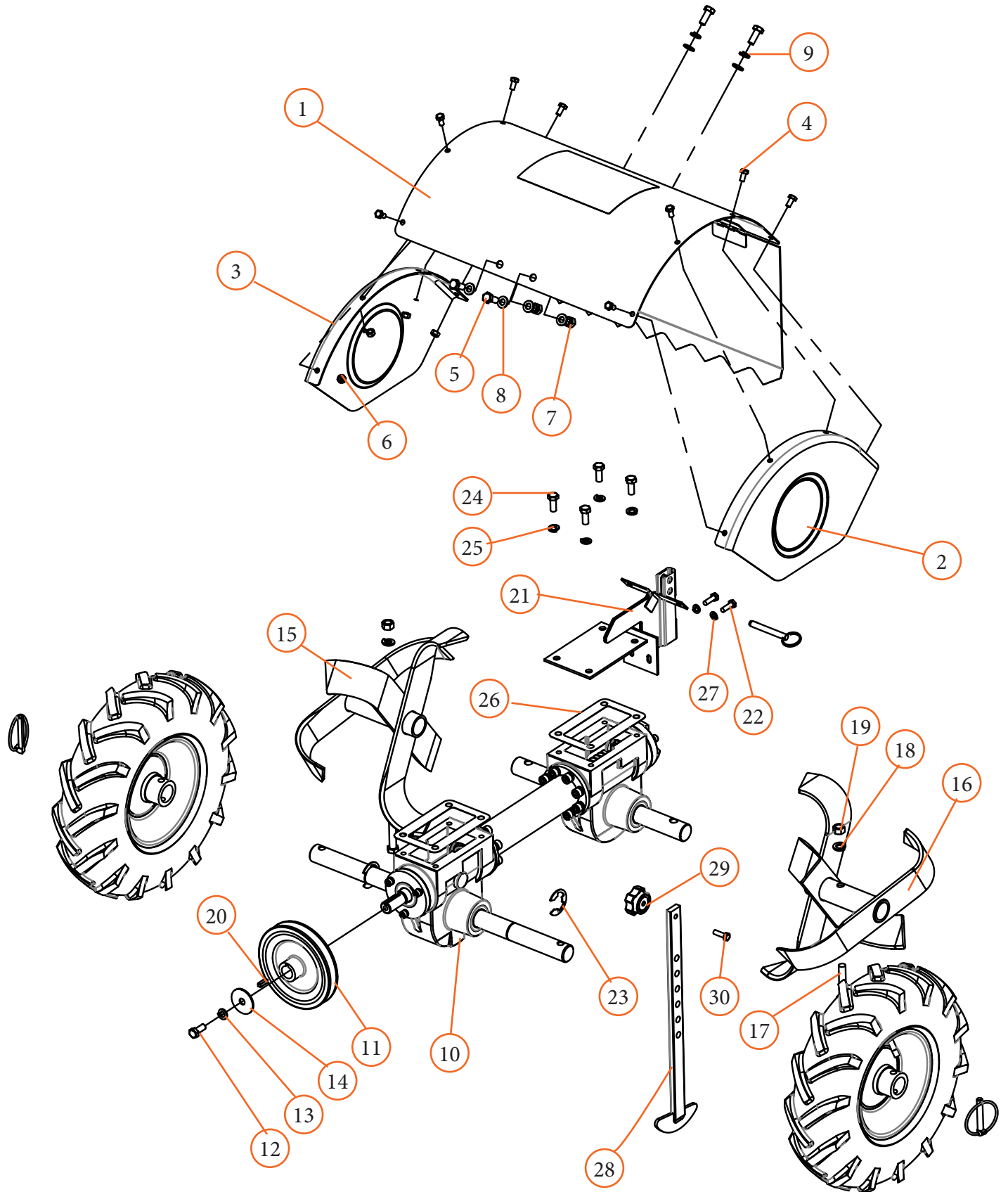

Tines and Safety Shields Parts List

Item #	Part #	Description	Qty.
1	101104	Tine Cover Assembly	1
2	101715	Tine Guard Left	1
3	101716	Tine Guide Right	1
4	101714	Hex Bolt, M6 x 1.0 x 12mm, G8.8	8
5	100125	Hex Bolt, M8 x 1.25 x 20mm G8.8	4
6	101494	Hex Nut, Nylock, M6 x 1.0, G8.8	8
7	100128	Hex Nut, Nylock, M8 x 1.25, G8.8	2
8	100130	Flat Washer, M8	6
9	100127	Lock Washer, M8	2
10	100888	Driveline Assembly	1
11	100885	Transmission Pulley	1
12	100125	Hex Bolt M8 x 1.25 x 20mm, G8.8	1
13	100127	Lock Washer, M8	1
14	100809	Flat Washer, 5/16 x 1-1/2"	1
15	100878	Tines Right	1
16	100877	Tines Left	1
17	100805	Hex Bolt, 3/8-16 x 2", G5	2
18	100611	Lock Washer, 3/8	2
19	100610	Hex Nut, 3/8-16, G5	2
20	100886	Pulley Key Bar	1
21	100873	Tail Mount	1
22	100085	Hex Bolt, M6 x 1.0 x 20mm, G8.8	2
23	100884	Retaining Ring, 1"	2
24	100125	Hex Bolt, M8 x 1.25 x 20mm, G8.8	4
25	100127	Lock Washer, M8	4
26	100887	Gearbox Gasket	2
27	100202	Lock Washer, M6	2
28	100883	Drag Bar	1
29	120880	Drag Bar Knob	1
30	100085	Hex Bolt, M6 x 20mm	1

Warranty & Specifications

IMPORTANT NOTICE

We, the manufacturer, reserve the right to change the product and/or specifications in this manual without notification. The manual is for information usage only and the pictures and drawings depicted herein are for reference only.

Warranty Repair and Service

Do not return this product to the store for warranty issues or repair. Call our customer service department at **720-287-5182**, **1-877-487-8275**, or visit www.dirtyhandtools.com for the location of the nearest service center.

Record the information below for future reference.

Model No. _____

Serial No. _____

Date of Purchase _____

Place of Purchase _____

Specifications

SKU/Part No.	100983
Description	Counter Rotating Rear Tine Tiller
Engine	6.5 HP 196CC Kohler SH265*, EPA/CARB Approved
Engine Oil Capacity**	0.63 quarts (0.6 liters)
Operating Speed	3600 RPM
Nominal Power Rating	4.476 kW
Tilling Width	16"
Tilling Depth	10"
Tires	12" diameter, 20 psi recommended pressure
Transmission	Neutral (disengaged), and Forward (engaged)
Transmission Capacity	18-22 ounces liquid grease (factory filled)
Dimensions	33"L x 19"W x 45"H (including handlebar)
Shipping Weight	145 Lbs.
Warranty	2 Year / 2 Year Limited Warranty

*As rated by engine manufacturer

** Not included, shipped without engine oil

Dirty Hand Tools® is a brand of
 **FrictionlessWorld**
1100 W 120th Ave., Suite 600
Westminster, CO 80234 • 720-287-5182

For Service or Questions
Call 1-877-487-8275
720-287-5182
www.dirtyhandtools.com