

OPERATING AND INSTALLATION OPERACIÓN E INSTALACIÓN UTILISATION ET INSTALLATION

DHW HEAT PUMP WATER HEATER
CALENTADOR DE AGUA CON BOMBA ELÉCTRICA DE CALOR
CHAUFFE-EAU THERMODYNAMIQUE

» ACCELERA® 300

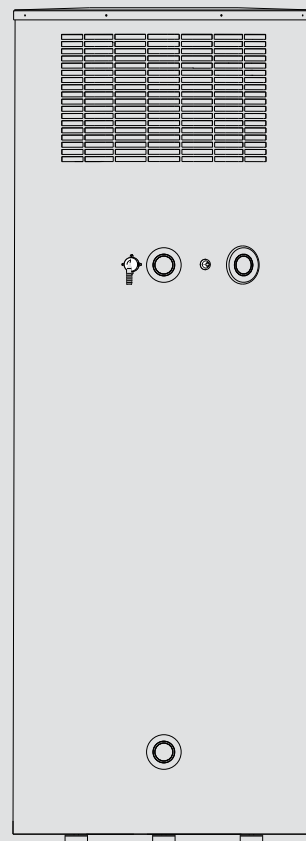

The Accelera® 300 Heat Pump Water Heater is tested and certified by WQA against NSF/ANSI 372 for lead free compliance.

STIEBEL ELTRON Inc.
17 West Street | West Hatfield MA 01088
Tel. 413-247-3380 | Fax 413-247-3369
Email info@stiebel-eltron-usa.com
www.stiebel-eltron-usa.com

STIEBEL ELTRON

A 280011-36221-8653

GENERAL INFORMATION

QUICK START-UP GUIDE



Please read
Read these instructions carefully and retain them for future reference. If the water heater is passed on to a third party please hand these instructions to the new user.

This manual includes important information regarding the safe and efficient handling of the water heater. Keep this manual with the water heater at all times.

Work must only be carried out by a licensed installer who has read and understands these instructions. All federal, state, and local codes must be followed. Failure to do so may result in equipment failure, serious injury, or death.

While working on the water heater, disconnect the power supply.

Illustrations in these instructions are designed to aid a general understanding and may deviate from the actual water heater version. No claims can be derived from such illustrations.

Limited liability:

We have collated all details and information in this manual in due consideration of applicable standards and regulations, the state of the art and our long-term know-how and experience.

Losses due to the following are excluded from our liability:

- Non-observance of these instructions
- Incorrect use
- Installation of the water heater by unqualified personnel
- Unauthorized modifications
- Technical modifications
- Use of unauthorized spare parts

Accelera® 300 Quick Start-up Guide

- A. **OVERVIEW:** This water heater hooks up like any other electric water heater, with a few minor exceptions. Be sure to follow all state and local codes during installation. This page is not intended to be a substitute for the installation manual. Be sure to follow all safety precautions.
- B. **UNPACKING:** DO NOT unpack water heater unit until it is located at the point of installation. Follow all instructions in the manual and be sure to use caution, as this unit is top heavy. DO NOT lay the unit down and DO NOT jar or tip the unit past 45 degrees on the hand truck. **See: 10.6**
- C. **INSTALLATION / WATER:**
- a. Location: Find a suitable location according to the manual. Minimum area is 10' x 10' x 8'. Be sure vents are parallel to the wall with the fan facing the most open area along that wall. Please note: a drain pan is recommended. **See: 10.6**
- b. 3/4" Inlet from union provided. For hook-up, follow all state and local codes for check valves, expansion tanks, shut off valves, gauges, etc. Install a 70 psi pressure reduction valve. Please note: water pressure should not exceed 0.48 MPa (70 psi). **See: 10.7**
- c. 3/4" Outlet from union to hot water line.
- d. Install T&P Relief valve (supplied). Please note: 0.69 MPa / 99 °C (100 psi / 210 °F).
- D. **CONDENSATE DRAIN:** Goes directly into a drain or use a condensate pump to drain into a suitable location. **See: 10.6.1**
- E. **FILL & FLUSH TANK:** Run water and be sure tank is full prior to turning on the electricity.
- F. **INSTALLATION / ELECTRICAL:** Use a 240 Volt / 15 Amp double pole breaker and connect to water heater L1, L2, and Ground. **See: 16.2**



WITHIN ABOUT 5 HOURS OF START-UP TIME, EXHAUST AIR FLOW SHOULD BE APPROXIMATELY -14,4 °C (6 °F) LESS THAN THE INLET SIDE.



CAUTION: RISK OF SCALDING. THERE IS A RISK OF SCALDING AT OUTLET TEMPERATURES EXCEEDING 43 °C (110 °F) RISK OF SCALDING

Copyright:

These operating and installation instructions are subject to copyright.

Transferring these instructions to third parties, copying of any kind, either in total or extracts therefrom, as well as their use and/or conveying its contents are prohibited without our written consent.

Contraventions are liable to claims for compensation. Further claims are reserved.

We hold the copyright:

STIEBEL ELTRON Inc.
17 West Street | West Hatfield MA 01088
Tel. 413-247-3380 | Fax 413-247-3369
Email info@stiebel-eltron-usa.com
www.stiebel-eltron-usa.com

Should you have any question regarding the installation or operation of the water heater, please contact our customer service. Tel. (USA) 800-582-8423 or 413-247-3380

Please record your serial number and information

Serial No.: _____

Date of Purchase: _____

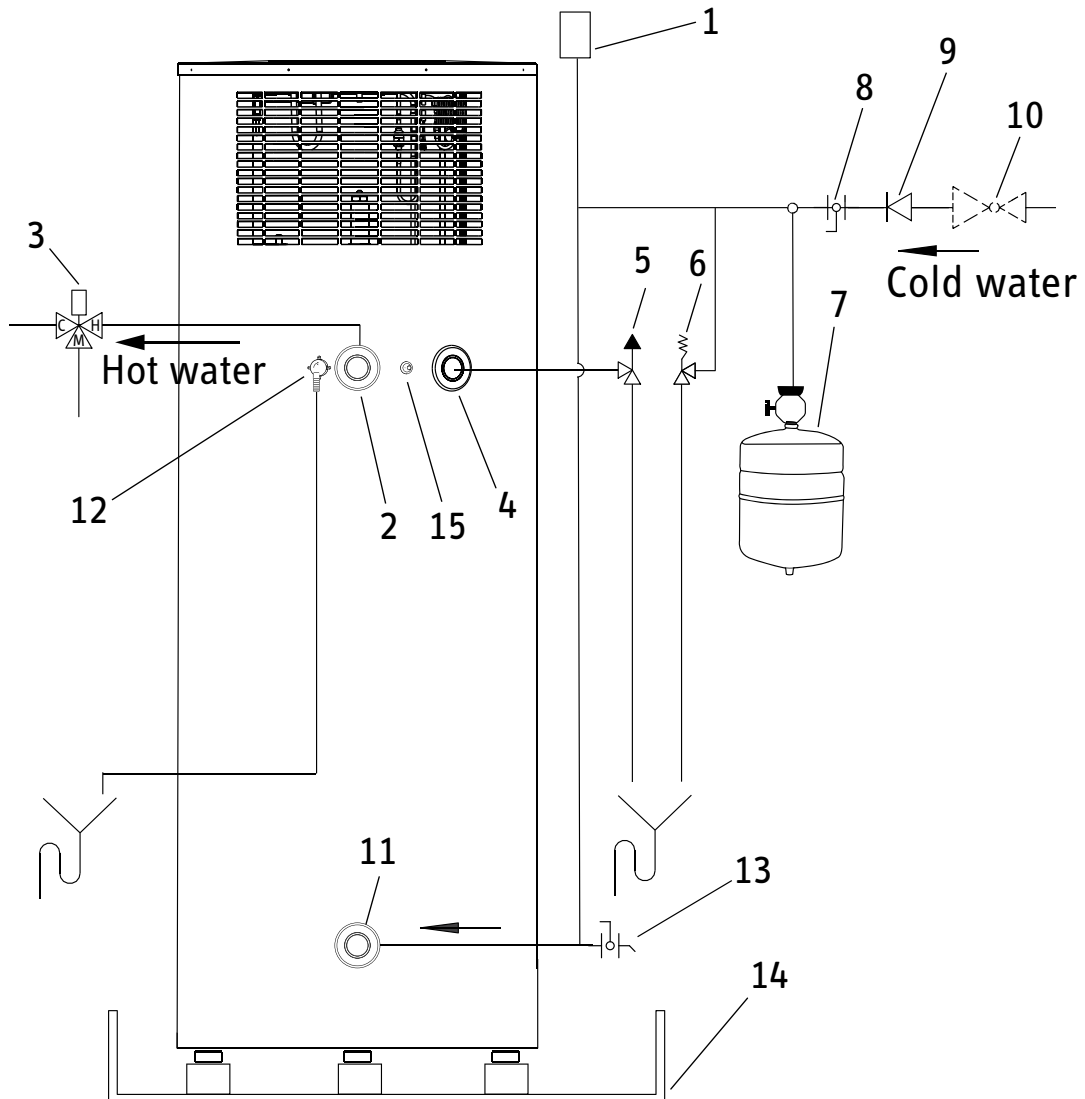

- 1 Vacuum breaker
- 2 Hot water connection (Union adaptor to 3/4")
- 3 Mixing valve (optional, supplied by installer)
- 4 Connection for T&P valve 3/4"
- 5 T&P valve 3/4", 0.69 MPa @99 °C (100 psi @210 °F) (supplied with unit)
- 6 0.551 MPa (80 psi) relief valve (optional, supplied by installer)
- 7 Expansion tank (optional, supplied by installer)
- 8 Straight-through shut-off valve (supplied by installer)
- 9 Check valve (optional, supplied by installer)
- 10 0.48 MPa (70 psi) pressure reduction valve (optional, supplied by installer)
- 11 Cold water connection (with Union adaptor to 3/4")
- 12 Condensate drain (elbow supplied with unit)
- 13 Drain valve (supplied by installer)
- 14 Drain pan (supplied by installer)
- 15 Condensate spillover

GENERAL INFORMATION	2	15. Maintenance and cleaning	20
QUICK START-UP GUIDE	2	15.1. Cleaning the evaporator	20
OPERATION	5	15.2. Draining the tank	20
1. Overview	5	15.3. Sacrificial anode rod	20
2. General information	5	15.4. Descaling	20
2.1. Key to symbols	5	15.5. Checking valves	21
3. Safety	9	16. Specification	21
3.1. General safety instructions	9	16.1. Connection and dimensions	21
3.2. Intended use	9	16.2. Wiring diagram	22
3.3. Incorrect use	9	16.3. Refrigerant diagram	23
3.4. Personnel qualification	9	16.4. Technical Data	24
3.5. Safety equipment	9	WARRANTY	27
3.6. Particular risks	9	ENVIRONMENT AND RECYCLING	27
4. Water heater description	10		
4.1. Function description	10		
5. Operation	10		
5.1. Initial start-up by a licensed installer	10		
5.2. Starting and stopping	10		
5.3. Emergency stop	10		
6. Maintenance and care	10		
6.1. Descaling	11		
7. What to do if ...	11		
7.1. ... the water heater does not deliver hot water	11		
7.2. ... the safety valve of the cold water supply line is dripping	11		
7.3. ... the condensate drain drips	11		
7.4. ... the power consumption is too high	11		
7.5. ... the room temperature drops excessively	11		
7.6. ... other faults occur	11		
8. Safety	11		
8.1. General safety instructions	11		
8.2. Incorrect use	12		
8.3. Qualification	12		
8.4. Instructions, standards and regulations	12		
8.5. Water installation	12		
8.6. Electrical installation	12		
9. Water heater description	12		
9.1. Standard delivery	13		
9.2. Special accessories	13		
10. Installation	13		
10.1. Installation location	13		
10.2. Shipping inspection	14		
10.3. Handling	14		
10.4. Storage	14		
10.5. Positioning the water heater	14		
10.6. Unpacking the water heater	14		
10.7. Water connection	17		
10.8. Power supply: 240V / 15A double pole circuit breaker	17		
11. Initial start-up	19		
11.1. Initial start-up	19		
11.2. Shutting down	19		
11.3. Restarting	19		
12. Settings	19		
12.1. Adjusting the water temperature	19		
13. Water heater hand over	19		
14. Troubleshooting	19		
14.1. Safety equipment of the water heater	19		
14.2. Troubleshooting	20		

OPERATION OVERVIEW

1. Overview

Front of the water heater

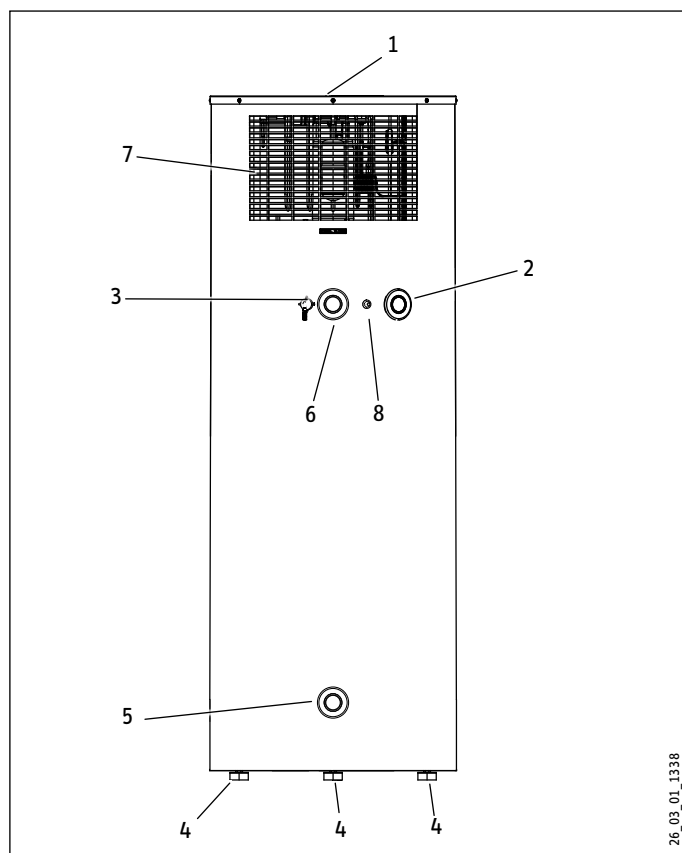

- 1 Water heater cover
- 2 Opening for PT valve
- 3 Condensate drain
- 4 Leveling feet
- 5 Cold water inlet
- 6 Hot water outlet
- 7 Air entry
- 8 Condensate spillover

An 80 gallon water tank is part of the water heater. Foam insulation is applied to the outside of the water tank to prevent heat losses. The water heater casing is made from powder-coated sheet steel.

The internally enameled water tank is supported by three height-adjustable anti-vibration leveling feet.

Back of the water heater

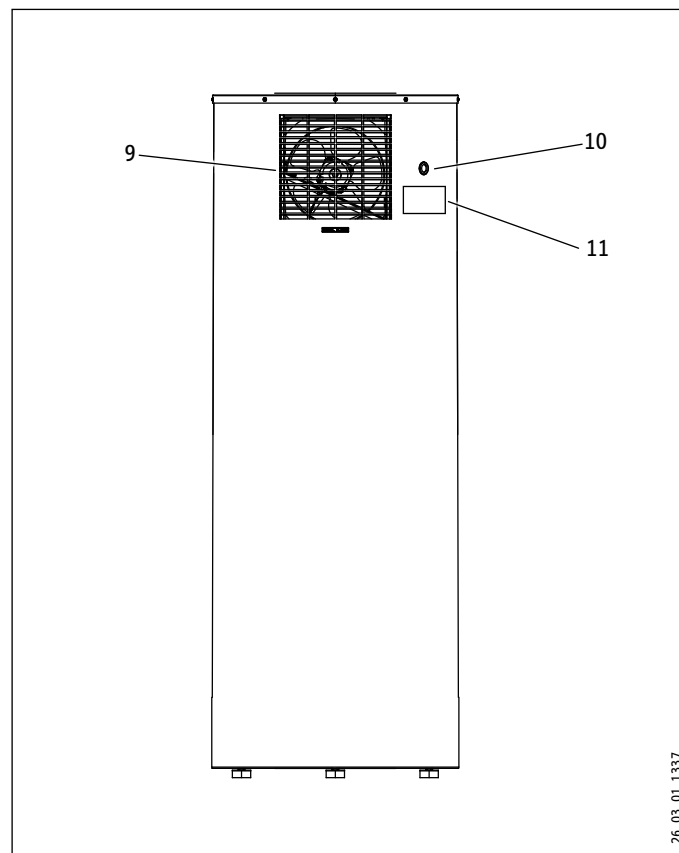

- 9 Air discharge
- 10 Entry for the power cable
- 11 Information labels, serial no.:

2. General information

The chapter **Operation** is intended for users and licensed installers.
The chapter **Installation** is intended for licensed installers only.

2.1 Key to symbols

2.1.1 Layout of safety information

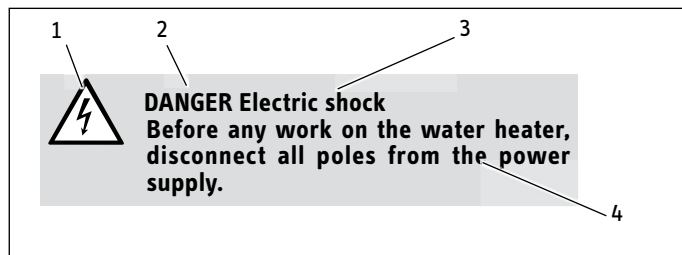

- 1 Symbol (see chapter "Symbols")
- 2 Keyword (see chapter "Keywords")
- 3 Designations (see chapter "Symbols")
- 4 Information text

2.1.2 Symbols

Symbol	Description
	Injury
	Electrocution
	Burns or scalding
	Other situations
	Fire
	Explosion
	Water heater disposal

2.1.3 Keywords

KEYWORD	
DANGER	The keyword DANGER indicates information that must be observed, otherwise serious injury or death will result.
WARNING	The keyword WARNING indicates information that must be observed, otherwise serious injury or death may result.
CAUTION	The keyword CAUTION indicates information that must be observed, otherwise relatively serious or light injuries may result.

2.1.4 Symbols in this documentation



Read the text next to this symbol carefully.

- » Passages with the symbol "»" indicate that you have to do something. The action you need to take is described step by step.
- Passages with this symbol "-" indicate lists.

2.1.5 Units of measure in this documentation



The dimensions in this document are given in millimeters (inches).

2.1.6 Information on the packaging

Information label "Top heavy"

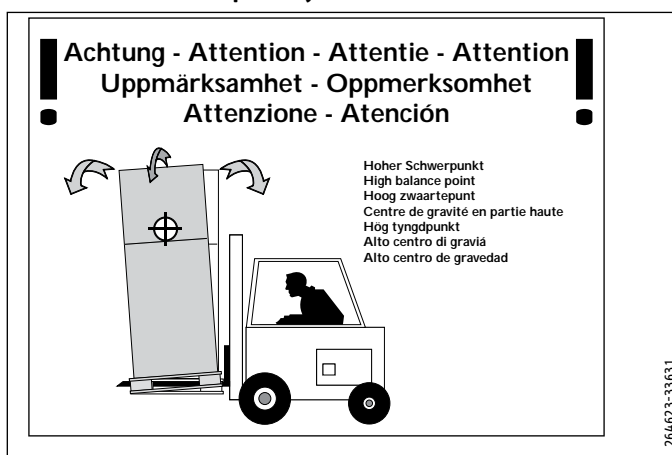

Information label "Vertical transport"

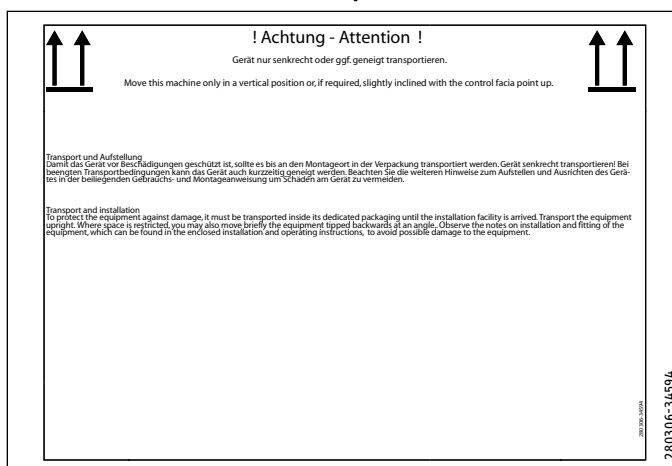

2.1.7 Information on the water heater

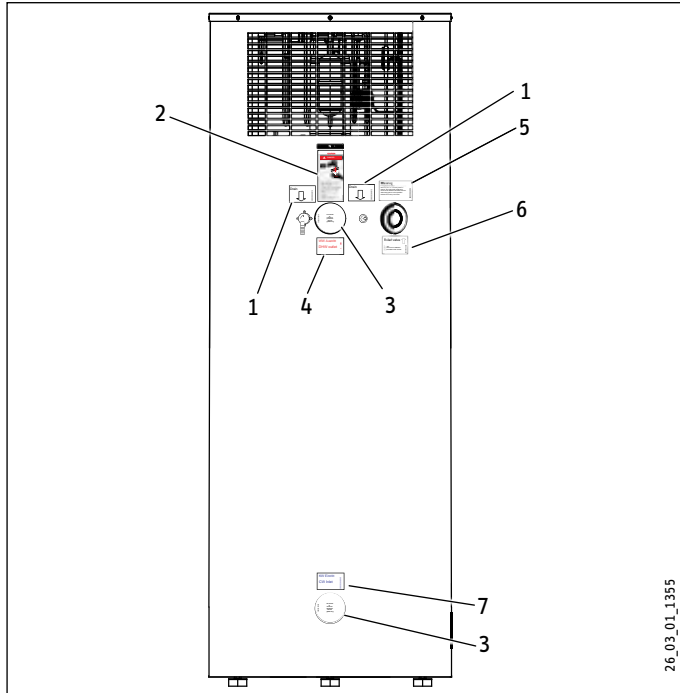

- 1 Information label "Condensate drain"
- 2 Information label "Risk of scalding"
- 3 Information label "Connection"
- 4 Information label "Hot water outlet"
- 5 Information label "Relief valve"
- 6 Information label "Relief valve installation location"
- 7 Information label "Cold water inlet"

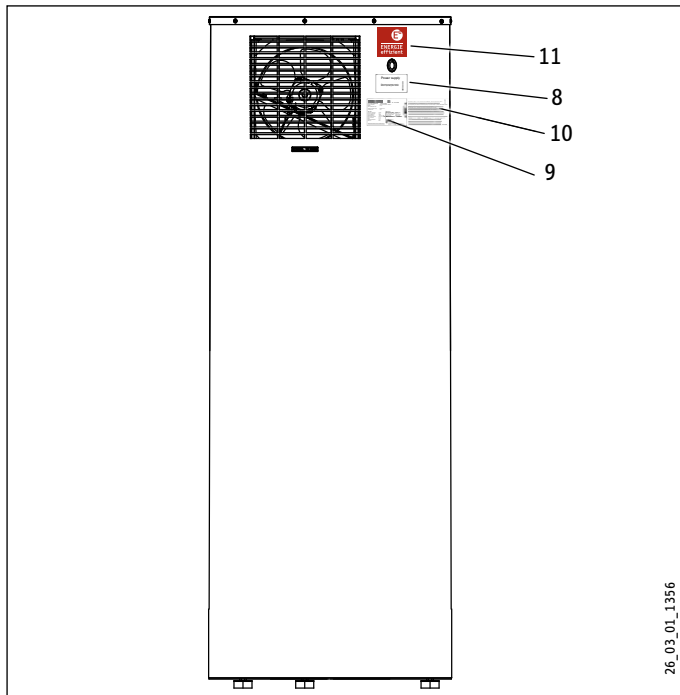

- 8 Information label "Power connection"
- 9 Type plate
- 10 Information label "Fluorated gases"
- 11 Information label "Energy efficiency"

1 Information label "Condensate drain"

This label shows you the position where the water heater drain is located.

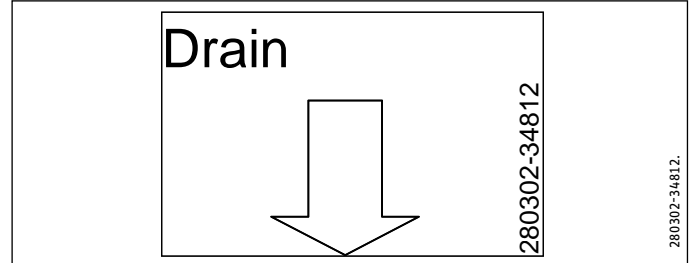

2 Information label "Risk of scalding"

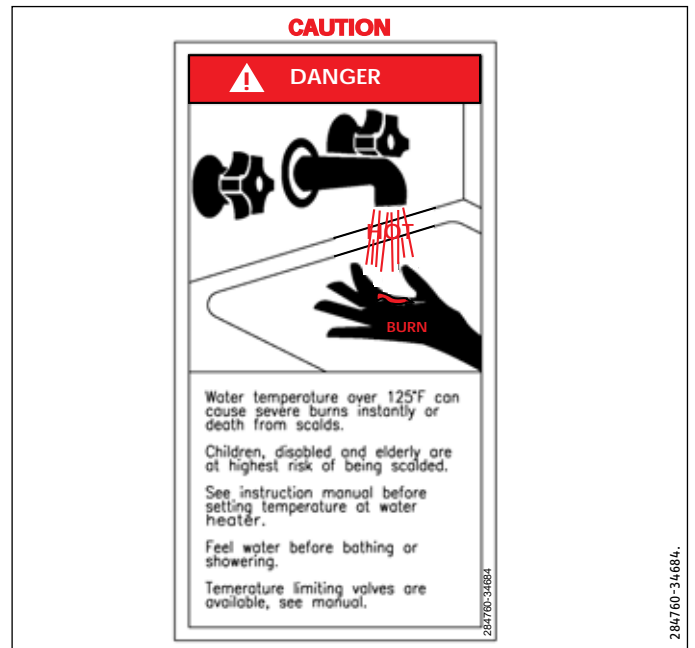

3 Information label "Connection"

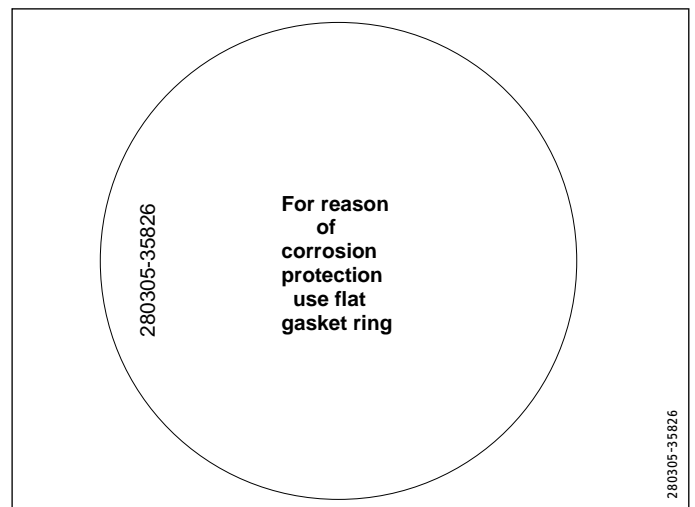

4 Information label "Hot water outlet"

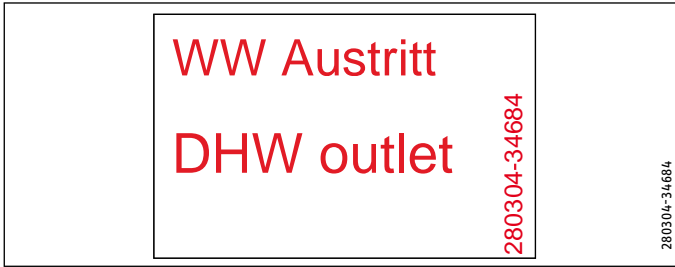

5 Information label "Relief valve"

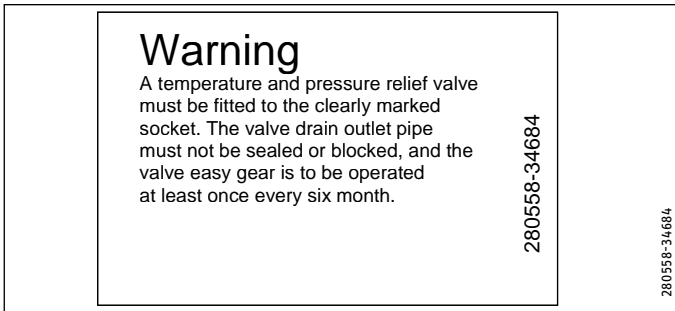

6 Information label "Relief valve installation location"

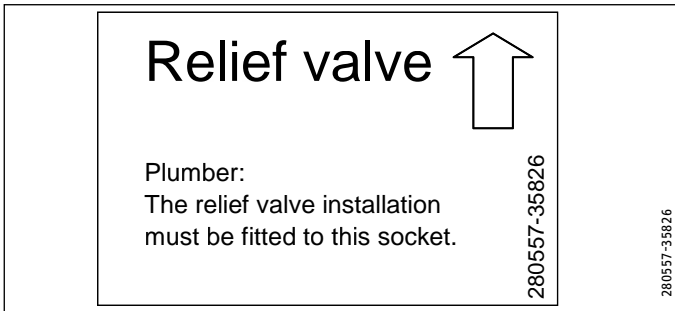

7 Information label "Cold water inlet"

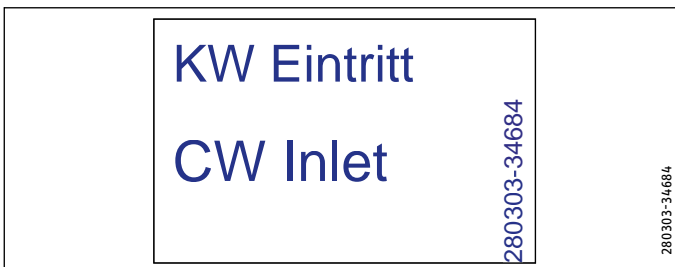

8 Information label "Power connection"

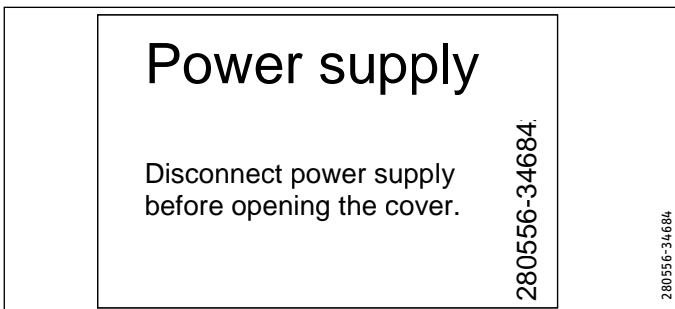

9 Type plate

STIEBEL ELTRON			No.: xxxx / xxxxxx
Type: Accelera 300/WHP 300	Order-No.: 222423		
Voltage / Frequency:	Single phase 220-240 V, 50/60 Hz		
Breaker:	15 amp.		
P _{Nmax} (rated power input):			
Limits for heat pump operation:	6 °C / +42 °C		
Maximum allowable ratings	2200 W, 9.17 A		
Protection class:	IP 24		
Heat pump:			
PN (Air 42° / Water 60°):	0.5 kW	DHW-cylinder:	Additional heating element: 1690 W
IN (Air 42° / Water 60°):	2.17 A	Max. operating pressure:	87 psi / 600 kPa
Type of Refrigerant:	R134a	Max. operating temperature:	168.8 °F / 76 °C
Refrigerant charge:	1.9842 Lb. / 900 g	Type of cylinder material:	Glass lined steel
Max. operating pressure:	348.1 psi / 2.4 MPa	Cylinder capacity:	80.044 Gal / 303 l
Lock rotor current:	13.4 A	Test pressure storage tank:	130.5 psi / 900 kPa
MCA:	10.4 A		
Rated load compressor:	2.3 A		
Motor fan:	38 W		
		STIEBEL ELTRON INC	
		17 West Street	
		West Hatfield, MA 01088	
		USA	
Observe the installation manual! Tested for leaks!		Made in Germany	282209-35793

10 Information label "Fluorated gases"

DE: Enthält vom Kyoto - Protokoll erfasste fluorierte Treibhausgase - hermetisch geschlossenes System.

GB: Contains fluorinated greenhouse gases covered by the Kyoto Protocol - hermetically sealed.

FR: Comprend les gaz à effet de serre fluorés enregistrés par le protocole de Kyoto - systèmes hermétiquement scellés.

NL: Bevat gefluoreerde broeikasgassen die onder het Kyoto-protocol vallen - hermetisch gesloten systeem.

SE: Innehåller av Kyoto - protokollat registrerade fluorerade växthusgaser i hermetiskt förslutna system.

PL: Zawiera fluorowane gazy cieplarniane ujęte w Protokole z Kioto - hermetycznie zamknięty układ.

CZ: Obsahuje fluorované skleníkové plyny, obsažené v Kjótském protokolu - hermeticky uzavřený systém.

HU: A Kiotói Jegyzőkönyv szerinti fluorotartalmú üvegházhatású gázokat tartalmaz - hermetikusan zárt rendszer.

IT: Contiene gas fluorurati ad effetto serra disciplinati dal protocollo di Kyoto - Impianto ermeticamente chiuso.

ES: Sistema herméticamente cerrado que contiene gases de efecto invernadero mencionados en el protocolo de Kioto.

BG: Съдържа посочените в Протокола от Киото флуорирани парникови газове - херметически затворена система.

RO: Conține un sistem închis ermetic contra emisiei de gaze fluorinate monitorizat de protocolul Kyoto.

DK: Indeholder fra Kyoto-protokollen registrerede, fluorerede drivhusgasser - hermetisk lukket system.

NO: Inneholder fluorerte drivhusgasser som omfattes av Kyoto-protokollen - hermetisk lukket system.

FI: Sisältää Kioton sopimuksen alaisia fluorattuja kasvihuonekaasuja - ilmativiisti suljettu järjestelmä. 284436-34741

11 Information label "Energy efficiency"



Maintain the legibility of all information labels. Illegible safety information and symbols can result in dangerous situations.

3. Safety

This chapter provides an overview of all important actions required for a safe and trouble-free operation.

3.1 General safety instructions

Operate the water heater only when fully installed and with all safety equipment in place.

Unsuitable tools or incorrect handling can result in damage to the water heater.



DANGER Scalding

The water is heated inside the water tank to 60 °C (140 °F). There is a risk of scalding at outlet temperatures above 43 °C (109 °F).

- » Ensure that outflowing water does not directly contact your body.



CAUTION Injury

Where children or persons with limited physical, sensory or mental capabilities are allowed to control this water heater, ensure that this will only happen under supervision or after appropriate instruction by a person responsible for their safety.

- » Children should be supervised to ensure that they never play with the water heater.



Never place any objects on top of the water heater.

Objects placed on top of the water heater can increase the noise level developed by the water heater through vibrations.



Never cover the water heater.

The water heater draws in air. Covering the inlet slots reduces the air intake. This reduces the efficiency of the water heater and can even lead to one of the safety devices interrupting the water heater operation.

3.2 Intended use

This water heater produces hot water automatically.

The water heater can be installed and operated in the open as well as in enclosed spaces. The temperature of the air that is drawn in during operation must not fall below 6 °C (43 °F).

Any other use beyond that described shall be deemed inappropriate. Observation of these instructions is also part of the correct use of this water heater.

Any changes or modifications to this water heater void all warranty rights.

3.3 Incorrect use

The following are not permitted:

- Do not heat anything other than potable water
- Do not use unqualified (unlicensed) personnel for installation
- Do not use in an environment with greasy extract air



This water heater must not be operated at ambient temperatures in excess of 42 °C (107 °F) or below 6 °C (43 °F).

If outside air is directly drawn in ensure, that the water heater is isolated from its power supply when the air temperature falls below 6 °C (43 °F).

3.4 Personnel qualification



DANGER Injury

Incorrect handling can result in severe injuries and material losses. Inadequately qualified personnel cannot assess the potential risks.

Have the installation, initial start-up, maintenance and repair steps carried out only by the qualified individuals specified in the respective chapters.

In the remainder of this manual, such qualified individuals will be described as the "licensed installer."

3.5 Safety equipment

Wear safety shoes/boots during the transportation and positioning of the water heater. Dry, this water heater weighs 130 kg (290 lb). Safety shoes/boots reduce the risk of injury.

3.6 Particular risks

3.6.1 Electric current



WARNING Electric shock

Contacting parts that carry live power is associated with a direct risk to life. Damaging the insulation or individual components can result in a risk to life.

- » If you detect damaged insulation, immediately switch off the power supply and arrange for the necessary repair.
- » Have all electrical work carried out by a qualified electrician.

3.6.2 Hot surfaces



CAUTION Burning

Contact with hot components can result in burning.

- » When working near hot components, wear protective clothing and gloves.
- » The pipework connected to the hot water outlet of the water heater can reach temperatures in excess of 60 °C (140 °F).

3.6.3 Refrigerant

The water heater is filled with R134A refrigerant at the factory.



WARNING Freezer burn

Should the water heater leak refrigerant, avoid contact with the refrigerant or breathing in any released vapors. Immediately vent the room.

In normal water heater operation, the refrigerant is contained in a sealed circuit.

4. Water heater description

This water heater is an automatic hot water generator with approx. 303 l (80 gallon) capacity. The hot water temperature is factory set to 60 °C (140 °F).

After opening a hot water faucet, the hot water is pushed out of the water heater by the incoming cold water.

This water heater works like an air conditioner but does not need to be vented. The water heater extracts heat from the ambient air to heat the water. The demand for electrical energy and the heat-up time depend on the ambient air temperature and humidity.

When installing the water heater inside, the space where it is installed will be cooled down during the operation by 1 to 3 °C (2 to 6 °F).

The water heater also extracts moisture from the air that creates condensate, which must be drained off. For this purpose, a condensate drain is integrated in the water heater. This is where you can connect a hose to a drain.

To protect the steel tank against corrosion, the interior is coated with a special enamel and is equipped with a replaceable sacrificial anode.

Heat pump function:

A sealed circuit inside the water heater contains R134A refrigerant (see "Specification/data table"); this does not deplete ozone, is non-flammable, and evaporates at low temperatures.

In the evaporator, where heat is extracted from the outside air, the refrigerant changes from its liquid into its gaseous state. A compressor draws in the gas in and compresses it. The increase in pressure raises the refrigerant temperature and heats the water tank.

This process requires electrical energy. The energy (motor heat) is not lost, but reaches the condenser downstream together with the compressed refrigerant. Here, the gas transfers heat to the water tank. An expansion valve then reduces the pressure and the process starts again.

4.1 Function description

4.1.1 Heat pump operation

The heat pump unit located on top of the water heater extracts heating energy from the ambient air.



If the water heater was separated from the power supply during operation, the compressor will only restart if the pressure inside the refrigerant circuit has been balanced. Pressure balance can only be created after waiting 15 minutes.

4.1.2 Booster heater

Primarily, the water inside the tank is heated by the heat pump.

When there is a higher hot water demand or when the water heater was switched OFF and you require hot water quickly, the integral booster heater will turn on. To save energy, the booster heater only heats the top third of the tank (approx. 102 l (27 gallons)).

A thermostat switches the booster heater on if the water temperature inside the tank falls below 45 °C (112 °F). A thermostat switches the booster heater off if the water temperature inside the tank exceeds 60 °C (140 °F).

4.1.3 Defrosting

The lower limit of use of the water heater is permanently set to 6 °C (42 °F). It is possible that at this limit, the evaporator will be

coated in frost. This is subject to the air temperature and humidity level, particularly at low hot water temperatures.

The compressor will be switched off as soon as the evaporation temperature falls below -7 °C (20 °F) for any length of time. When the temperature at the evaporator fins rises above 3 °C (38 °F), the compressor starts again, and the hot water heating continues. The fan continues to run during defrosting.

5. Operation

You do not have to make any adjustments. The water heater is therefore not equipped with any controls. The hot water temperature is factory set to 60 °C (140 °F).

Should you wish to operate with different settings, contact your local licensed installer.



WARNING Scalding

The water is heated inside the water tank to 60 °C (140 °F). There is a risk of scalding at outlet temperatures in excess of 42 °C (108 °F). Ensure that outflowing water does not directly contact your body.

5.1 Initial start-up by a licensed installer

Initial start-up should be done by a licensed installer.

5.2 Starting and stopping

The water heater is not equipped with an ON/OFF switch. If a power plug was fitted during installation, you can disconnect the water heater from the power supply by pulling that plug. Alternatively, you can terminate the water heater operation by tripping the circuit breaker.

5.3 Emergency stop

In case of emergency, carry out the following steps:

- » Isolate the power supply by tripping the circuit breaker or by pulling the power plug.
- » Shut off the cold water inlet.

6. Maintenance and care

A damp cloth is sufficient for cleaning the exterior of the water heater. Never use abrasive or corrosive cleaning agents. Do not hose down the water heater.

- » Monthly, check that the condensate drain is clear.
- » Monthly, carry out a visual inspection of the condensate pan drain (in the top of the water heater; see the following diagram). Look through the air intake grille at the front of the water heater. If required, notify your local licensed installer who will remove any contamination.

OPERATION

WHAT TO DO IF ...

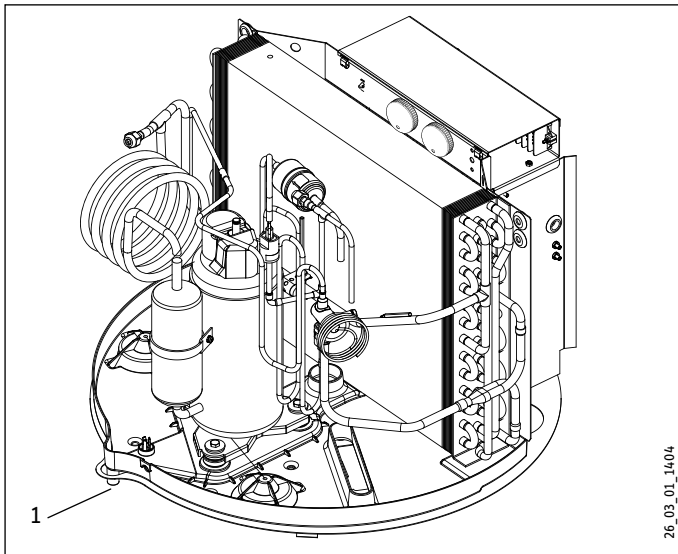

1 Condensate pan drain

6.1 Descaling

At high temperatures water separates out lime. This is deposited on the inside of the tank. With increasing limescale build-up, the amount of hot water inside the tank is reduced.

- » Have a licensed installer descale the booster heater from time to time. This extends the service life of the booster heater.
- » Scale cannot build up on the heat pump element.

A licensed installer who knows the local water quality will tell you when the next maintenance appointment is due.

- » Have your licensed installer check the sacrificial anode regularly.

7. What to do if ...

7.1 ... the water heater does not deliver hot water

- » Check the water heater power supply.
- » Check your fuse box for a tripped circuit breaker.
- » Make sure there is a 15 A double pole circuit breaker

If the circuit breaker has tripped, reset it or replace it. Notify your local licensed installer if the circuit breaker trips again.

- » Ensure that the air intake and air discharge are unobstructed.

Excessively high ambient temperature, excessively high temperature of the air drawn in (> 42 °C (108 °F)) or a fault in the refrigerant circuit can result in the compressor being overloaded. The thermal protective 'auto reset' motor switch or the high limit 'manual reset' cut-out can both shut off the compressor off.



The high limit pressure limiter must only be reset by your licensed installer after they have removed the cause of the relevant fault.

After a short cooling down period, the thermal protective motor auto reset switch will restart the compressor automatically.

Notify your local licensed installer if the water heater does not restart automatically.

7.2 ... the safety valve of the cold water supply line is dripping

This unit can operate up to 0.48 MPa (70 psi) of inlet pressure. Expansion water drips from the safety valve during heat-up. This is completely normal. Notify your local licensed installer if water still drips after heat-up has been completed.

7.3 ... the condensate drain drips

This is quite normal and always happens when the surface temperature of the evaporator is lower than the dew point temperature of the ambient air.

7.4 ... the power consumption is too high

Please consult a qualified licensed installer.

7.5 ... the room temperature drops excessively

The water heater operation reduces the ambient air by 1 to 3 °C (2 to 6 °F). Notify your local licensed installer if the ambient temperature drops abnormally.

7.6 ... other faults occur

Notify your local licensed installer. Refer to the water heater number on the type plate next to the barcode.

STIEBEL ELTRON			No.: xxxx / xxxxxx
Type: Accelera 300/WHP 300	Order-No.: 222423		
Voltage / Frequency:	Single phase 220-240 V, 50/60 Hz		
Breaker:	15 amp.		
P _{Nmax} (rated power input):			
Limits for heat pump operation:	6 °C / +42 °C		
Maximum allowable ratings	2200 W, 9.17 A		
Protection class:	IP 24		
Heat pump:			
PN (Air 42° / Water 60°):	0.5 kW		
IN (Air 42° / Water 60°):	2.17 A		
Type of Refrigerant:	R134a		
Refrigerant charge:	1.9842 Lb. /900 g		
Max. operating pressure:	348.1 psi /2.4 MPa		
Lock rotor current:	13.4 A		
MCA:	10.4 A		
Rated load compressor:	2.3 A		
Motor fan:	38 W		
		DHW-cylinder: Additional heating element: 1690 W Max. operating pressure: 87 psi /600 kPa Max. operating temperature: 168.8 °F /76 °C Type of cylinder material: Glass lined steel Cylinder capacity: 80.044 Gal /303 l Test pressure storage tank: 130.5 psi / 900 kPa	
		STIEBEL ELTRON INC 17 West Street West Hatfield, MA 01088 USA	
Observe the installation manual! Tested for leaks!		Made in Germany	282209-35793

1 Water heater number

8. Safety

Only qualified licensed installers should carry out installation, initial start-up, maintenance and repair of the water heater.

8.1 General safety instructions

Use only original accessories and spare parts intended for this water heater.



DANGER Electric shock

Disconnect the water heater from the power supply prior to its installation.



WARNING Injury

If the pipes inside the water heater are damaged, leaking refrigerant gas can result in severe physical freezer burns.

Do not inhale refrigerant. Immediately vent the room thoroughly.

- » **Wear safety goggles and gloves during water heater installation.**



WARNING Injury

Moving parts represent a risk of injury.

- » Before opening the water heater, ensure that the fan has come to a complete standstill.

8.2 Incorrect use

The following are not permitted:

- Do not install the water heater on non-load bearing floors
- Do not install the water heater where it is at risk from frost
- Do not install in rooms where the water heater is at risk from explosions as a result of dust, gases or vapors
- Do not ignore safety clearances and safety zones
- Do not incorrectly install the power connection
- Do not operate the water heater with the tank empty
- Do not operate the water heater with an open casing
- Do not heat anything other than potable water
- Do not fill with any other Freon, use only R134A

8.3 Qualification



WARNING Injury

Incorrect handling can result in severe injuries and material losses. Inadequately qualified personnel cannot assess the impending danger.

Have only personnel mentioned in the appropriate sections of this manual carry out specific measures.

In this manual, such qualified individuals will be described as the "licensed installer".

Licensed installers are responsible for adherence to all currently applicable regulations during installation and initial start-up.

8.3.1 Licensed installer

Licensed installers are specially trained in their field. Licensed installers work on systems on the basis of their training, knowledge and experience, as well as their knowledge of applicable standards and regulations. They are able on their own to recognize and prevent possible problems.

8.3.2 Electrician (licensed)

An electrician is a licensed installer who meets the above requirements with regard to electrical installations.

8.3.3 Plumber (licensed)

A plumber is a licensed installer who meets the above requirements with regard to water-related installations.

8.3.4 Customer service

For customer service inquiries, please contact Stiebel Eltron directly at 1-800-582-8423, ext. 25 or ext. 33.

8.4 Instructions, standards and regulations



Follow all national, state, and local codes.

Observe the regulations of your local energy and water supply utilities.

The following standards were taken into account:

UL 499, UL 1995, UL 94-5 VA, UL 174

IEC 60335-1-2-40, IEC 61000-3-2; 1995

IEC 61000-3-3, IEC 55014-1 IEC 55014-2

EMC Directive 89/336/EEC

EN 255 T3

Read the water heater type plate and the chapter "Specification".

8.5 Water installation

The following materials may be used:

- Cold water line: steel, copper or plastic pipework.
- Hot water line: copper or plastic pipework.
- » Ensure that no contamination reaches the water heater through the pipework.

8.6 Electrical installation

Protect the water heater electrically with a 15 A double pole circuit breaker.

Where the water heater is permanently connected to the power supply, it must be able to be separated from the mains power supply by an additional isolator that disconnects all poles with at least 3 mm (0.12 ") contact separation. For this purpose, use contractors, circuit breakers, fuses, etc. on site.

In case of a fault, the safety equipment interrupts the relevant power circuit.

9. Water heater description

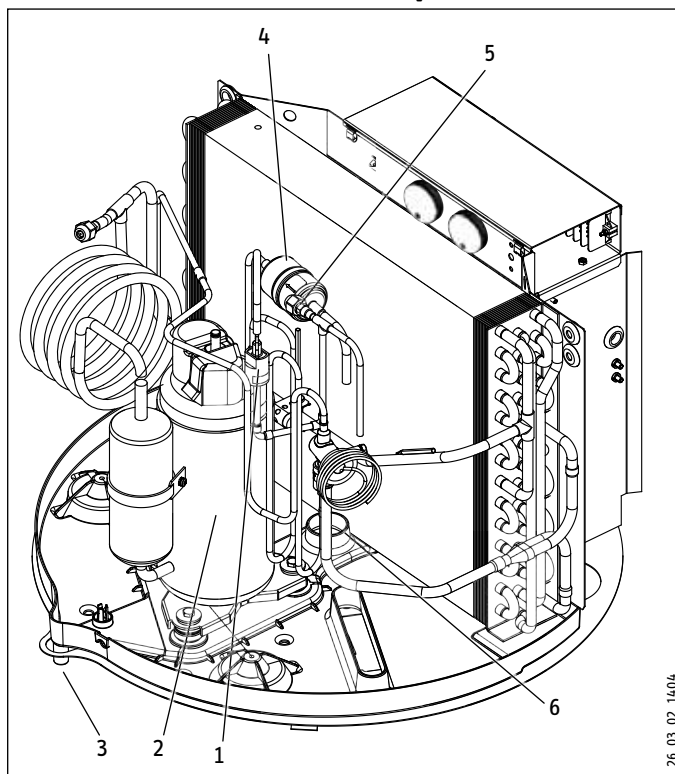

- 1 High limit safety cut-out - manual reset
- 2 Compressor
- 3 Condensate drain
- 4 Filter dryer
- 5 Service valve, high pressure
- 6 Sacrificial anode

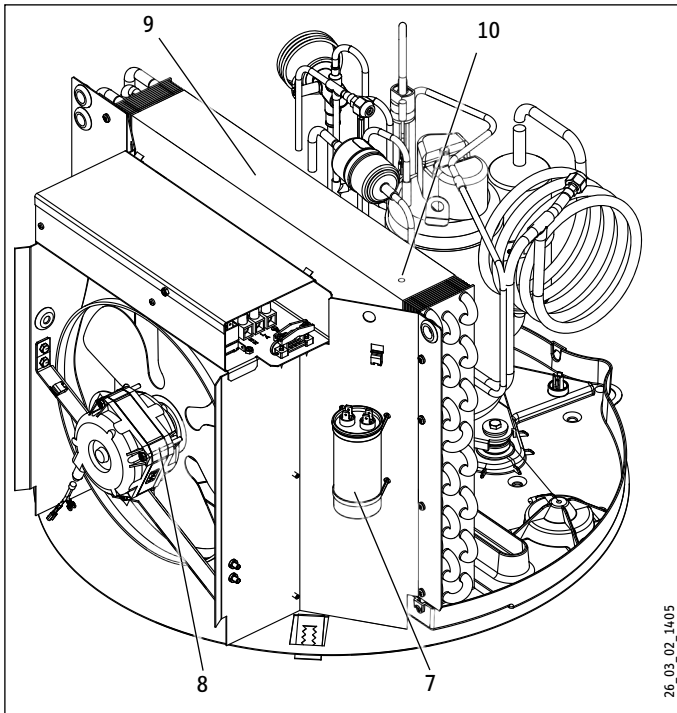

- 7 Capacitor
- 8 Fan
- 9 Evaporator
- 10 Defrost sensor

26_03_02_1405



The hot water thermostat temperature is preset at the factory. Where customers require a lower hot water temperature, the thermostat settings of the heat pump and the booster heater can be reduced.

A sacrificial anode rod is installed in the top of the water heater. (6)

9.1 Standard delivery

- Accelera 300 heat pump water heater
- Two adaptors, Union to 3/4"
- Two union gaskets

9.2 Special accessories

Description	Part number
Anode rod	278235
Segmented anode rod	143498

10. Installation



CAUTION Injury

Incorrect installation can result in severe injuries and material losses. Prior to installation ensure you have adequate space for the work to be carried out. Handle components with sharp edges carefully.



The sheet steel casing of the water heater is not designed to withstand heavy forces. Handle and install the water heater with care.

10.1 Installation location



DANGER Explosion

Never install the water heater in rooms where it is at risk from explosions as a result of dust, gases or vapors.



WARNING Injury

The room where the water heater is to be installed must have a load-bearing floor. There is a risk of the water heater breaking through the floor if the substrate has insufficient load-bearing capacity. The wet weight of the water heater is approx. 430 kg (950 lb). If the floor offers inadequate load-bearing capacity, there is a risk of the water heater breaking through the floor, resulting in a risk to life.



Risk of frost damage

Install the water heater only in an area free from the risk of frost. When the water heater is not in use and there is a risk of frost, the water inside the water tank can freeze and damage the tank.

- Never install the water heater in areas where the air temperature regularly drops below 6 °C (42 °F) or rises above 42 °C (108 °F).
- To prevent nuisance through operating noise, never install the water heater in the vicinity of bedrooms. Prevent noise emissions towards a neighbor.
- Allow adequate space around the water heater for installation, maintenance and cleaning tasks.

With internal installations, also observe the following:

- The available floor area in the installation room must be at least 6 m² (10' x 10' - 100 ft²). The room volume must not be less than 13 m³ (500 ft³).
- The water heater must not be restricted by walls and ceilings. The required minimum clearances are specified in chapter "Positioning the water heater/positioning conditions" (see chapter 10.5, "Positioning the water heater").
- Observe that the room temperature will drop by 1 to 3 °C (2 to 6 °F) as a result of the water heater operation.
- When installing the water heater in a furnace room, ensure that the furnace operation will not be impaired.
- To keep line runs as short as possible, we recommend that the water heater is installed near the kitchen or bathroom.

10.2 Shipping inspection

» Upon receipt, check your delivery for completeness and possible transport damage.

If transport damage is visible, proceed as follows:

- Do not accept the delivery or only with reservations.
- Note down the extent of the damage on the shipping documents or on the delivery note of the carrier.
- Initiate a complaint.



Immediately give notice of any damage.
Give notice of all damage as soon as it has been identified. Claims can only be accepted within the applicable claim period.

10.3 Handling



CAUTION Injury through heavy loads

Dry, this water heater weighs 130 kg (290 lb.). Use suitable aids and sufficient personnel when handling this water heater.



Risk of damage through incorrect handling.
Incorrect handling can result in substantial material losses.
Observe the information on the packaging.
Remove the packaging just before the installation.



Risk of damage through overturning.
The water heater has a high centre of gravity and a low overturning moment. Protect the water heater against overturning.
Only position the water heater on a level substrate.

To protect the water heater against damage, it should be transported vertically inside its packaging. Where space is restricted, you can also tilt (max. 45 °) the water heater briefly to move it.

10.4 Storage

Where it is necessary to store the water heater prior to installation for a longer period, observe the following:

- If possible, store the water heater in a dry and dust-free ambience.
- Prevent the water heater from coming into contact with aggressive materials.
- Prevent the water heater from being exposed to shocks or vibrations.
- In case of prolonged storage, check the condition of the water heater and its packaging regularly.

10.5 Positioning the water heater

» Position the water heater with its wooden pallet at the final installation location in a 10' x 10' x 8' area.

Install the water heater so that there is an adequate clearance adjacent to the air grilles (see the following diagrams).

10.5.1 Installation conditions

It is important for the water heater maintenance that adequate space remains available above the water heater.

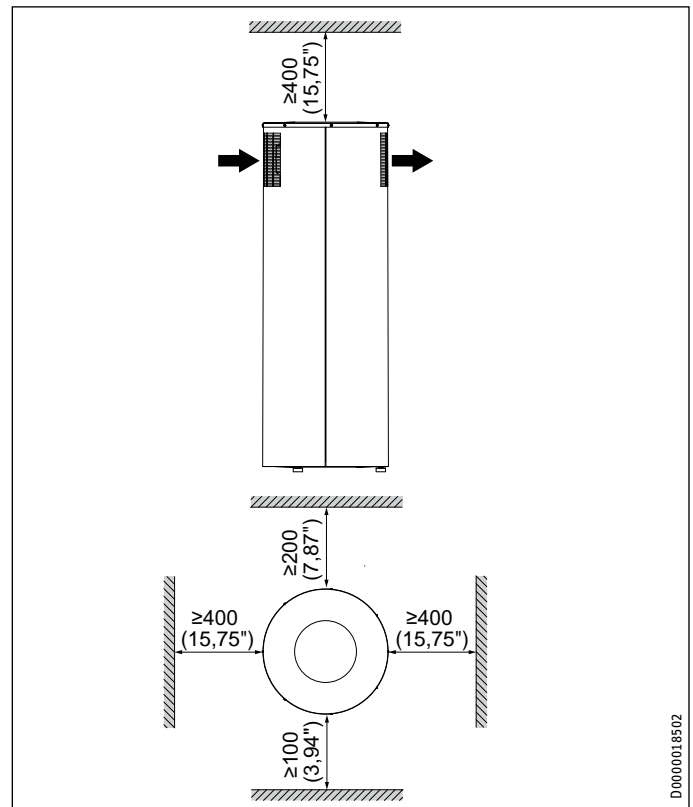

» Level the water heater horizontally by adjusting the feet.

10.6 Unpacking the water heater



Ensure that the casing material in the lower section will not be damaged.



Advice - The longer you keep the packaging foil wrapped around the water heater, the longer it will be protected against damage.

- » Remove the packaging straps.
- » Push the packaging foil far enough upwards that the pallet is freely accessible.
- » Remove the water heater carefully with the polystyrene® packaging from the pallet.



DANGER Injury from tipping over
The water heater has a high centre of gravity and a low overturning moment. Ensure that the water heater does not overturn when you remove it from its pallet.

- » Slide the packaging foil far enough upwards to be able to remove the first polystyrene® profiles from the sides. These polystyrene® profiles on the sides are used as installation aids in the following steps.

INSTALLATION

INSTALLATION

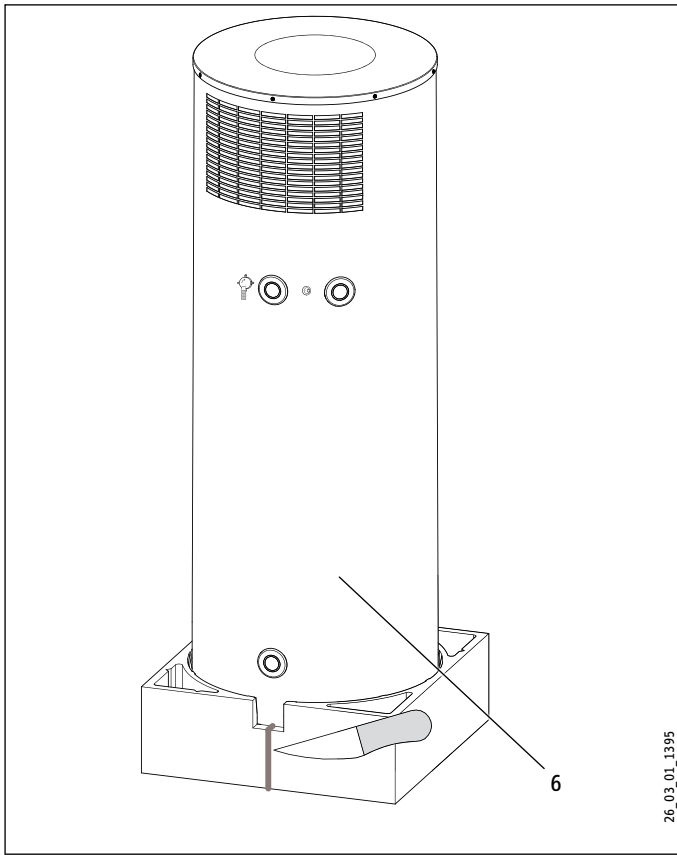

26_03_01_1395

- » Separate the lower packaging section at the dividing line. For this, make an incision of approx. 30 mm (1.25") into both sides of the dividing line.

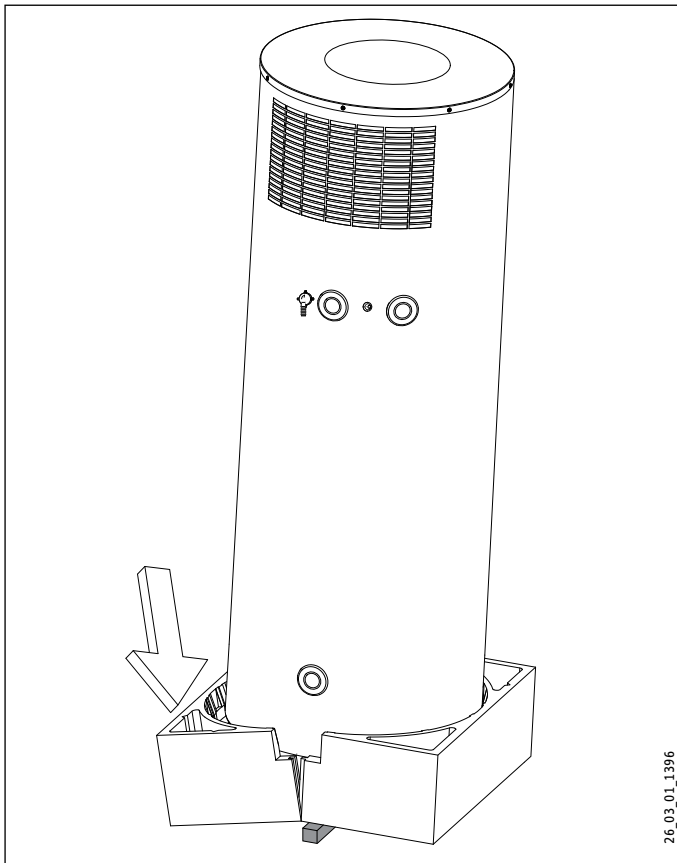

26_03_01_1396

- » Slightly tilt the water heater.



DANGER Injury from overturning
Secure the water heater against overturning by getting a second person to support the water heater.

- » Push a wooden support underneath the lower part of the packaging.
- » Break out the free semi-shell of the lower section of the packaging.
- » Keep the water heaters slightly tilted.
- » Wind out the free leveling foot, but not by more than 30 mm (1.1").
- » Turn the locking nut on the thread of the leveling foot towards the bottom cover. When the locking nut is tight against the bottom cover, it stabilizes the leveling foot.

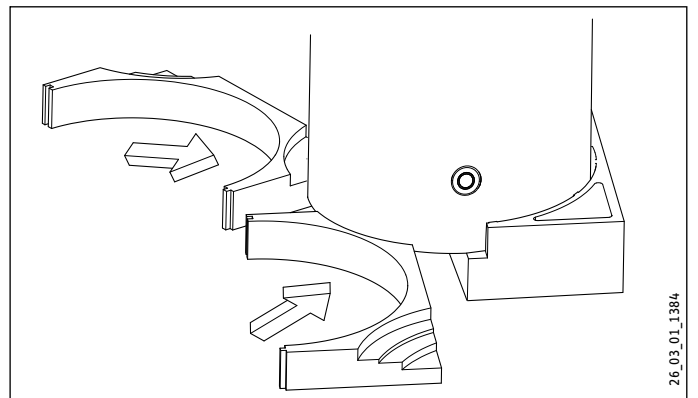

26_03_01_1384

- » Push two polystyrene® installation aids with the step-shaped corner underneath the water heater. The water heater is subsequently set and tilted onto this profile. Ensure that you do not set the water heater down in the area of the joint edge of the sheet steel jacket, but at least 150 mm (6") along.

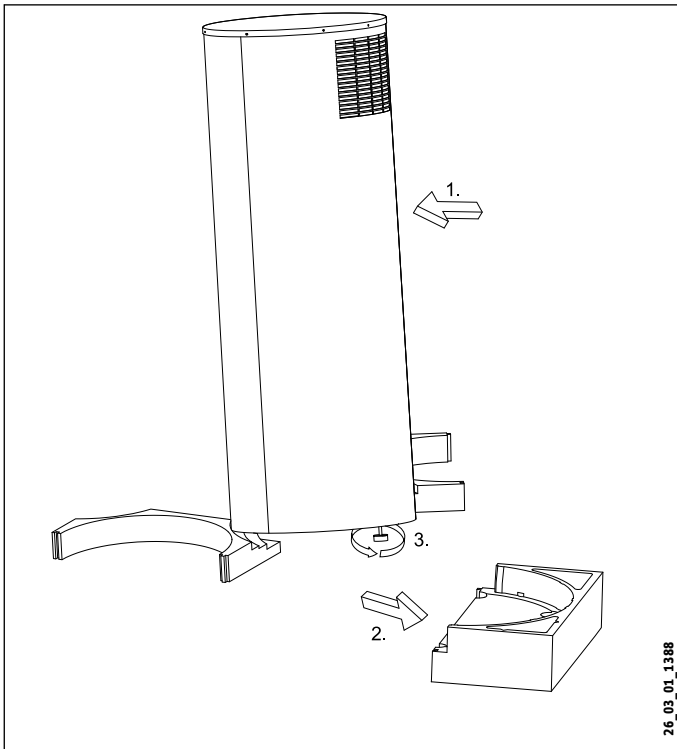

- » Tilt the water heater that has been set down on the polystyrene® installation aids.
- » Remove the remaining floor semi-shell.
- » In the tilted state of the water heater, wind out the second and third leveling foot, but not by more than 30 mm (1.1").
- » In both cases, tighten the locking nut against the bottom cover.
- » Position the water heater on the three leveling feet.
- » Level the water heater vertically by adjusting the three leveling feet.
- » Remove any packaging that remains on the water heater.
- » Install condensate drain elbow.

10.6.1 Condensate drain

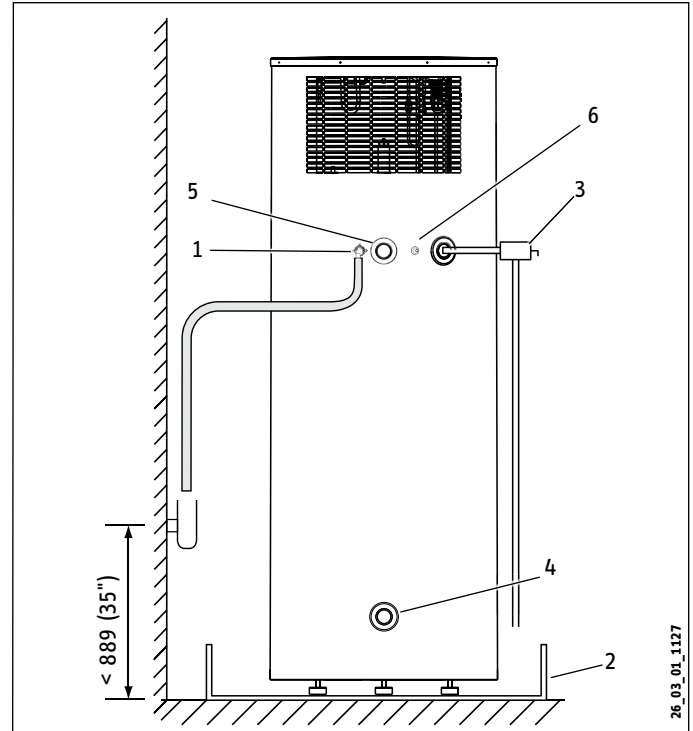

- 1 Condensate drain or
- 2 Drain pan connected to drain
- 3 T&P valve
- 4 Cold water connection
- 5 Hot water connection
- 6 Condensate spillover

The condensate drain is located on the side of the water heater. This is where you can connect a drain hose.

When installing the unit outdoors, the condensate can drain off freely.

For indoor installation, the condensate can be routed into a floor drain or routed through the wall up to 889 mm (35") (see diagram above).

If required, install a condensate pump.



To ensure the condensate drains correctly, never kink the hose.

10.7 Water connection

The water connection must be carried out by a qualified licensed plumber.

The cold water connection must comply with DIN 1988 [or state and local codes]

» Prior to installing the water heater, flush the line thoroughly.

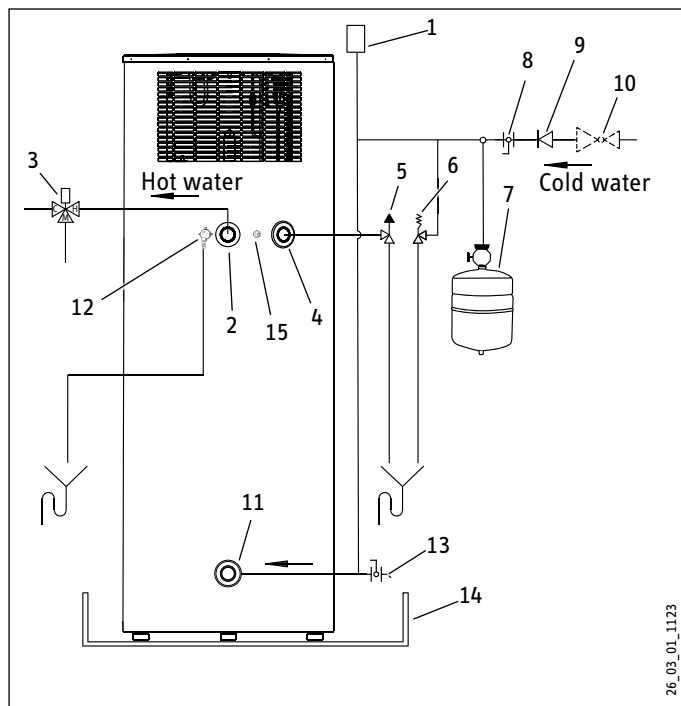

- 1 Vacuum breaker
- 2 Hot water connection (Union adaptor to 3/4")
- 3 Mixing valve (optional, supplied by installer)
- 4 Connection for T&P valve 3/4"
- 5 T&P valve 3/4", 0.69 MPa @99 °C (100 psi @210 °F) (supplied with unit)
- 6 0.551 MPa (80 psi) relief valve (optional, supplied by installer)
- 7 Expansion tank (optional, supplied by installer)
- 8 Straight-through shut-off valve (supplied by installer)
- 9 Check valve (optional, supplied by installer)
- 10 0.48 MPa (70 psi) pressure reduction valve (optional, supplied by installer)
- 11 Cold water connection (with Union adaptor to 3/4")
- 12 Condensate drain (elbow supplied with unit)
- 13 Drain valve (supplied by installer)
- 14 Drain pan (supplied by installer)
- 15 Condensate spillover

- » Remove the protective rubber caps from the connectors.
- » With a sharp knife, cut a hole into the protective caps and install them over the pipe to be connected.
- » Connect the plumbing.
- » After connecting the plumbing, connect the protective caps so that the sheet steel casing of the water heater grips into the outer groove of the protective cap.



Risk of damage through corrosion
To protect against the risk of corrosion, make the connection with flat gaskets.

- » Insulate the hot water line against heat loss.

- » Install a drain valve at the lowest point of the cold water supply.

Install a 0.48 MPa (70 psi) pressure reducing valve on the cold water inlet.

Accurately maintain the order of fittings on the cold water side (see diagram 10.7).

10.7.1 Safety valve (on-site provision)

This water heater is a sealed unit. A 0.69 MPa, 99 °C (100 psi, 210 °F) T&P relief valve must be installed.

When installing the T&P valve, observe the following:

- Size the drain line so that water can drain off completely, even if the safety valve is fully open.
- The drain outlet must not be able to be closed and must always remain open to atmosphere.
- The T&P valve must open at a pressure of 0.69 MPa (100 psi) and be 3/4" pipe thread.

10.7.2 T&P valve (on-site provision)



WARNING Risk of injury through excessive pressure and temperatures.

Install safety equipment that meets the applicable regulations for the installation locations. In any case install a "Pressure and Temperature Relief valve (T&P relief)" that complies with the requirements of the ANSI Z21.22 ("Requirements for Relief Valves and Automatic Gas Shut-off Water heaters for Hot Water Supply Systems").

The T&P valve must respond at a pressure of 0.69 MPa (100 psi). Fit the T&P valve into the opening on the circumference of the water heater indicated.

Ensure that any expelled water cannot come into contact with 'live' parts and will not run onto sensitive surfaces. Ensure that the T&P valve outlet remains free at all times.

10.8 Power supply: 240V / 15A double pole circuit breaker

The electrical connection must be carried out by a qualified electrician.



DANGER Electric shock

- » Contacting 'live' components results in a risk to life.
- » Disconnect the water heater from the power supply before carrying out work on the control panel.
- » Be sure that no one can reconnect the power while you are working.

When making a connection use code compliant disconnects.

- » Undo the screws and remove the water heater cover.

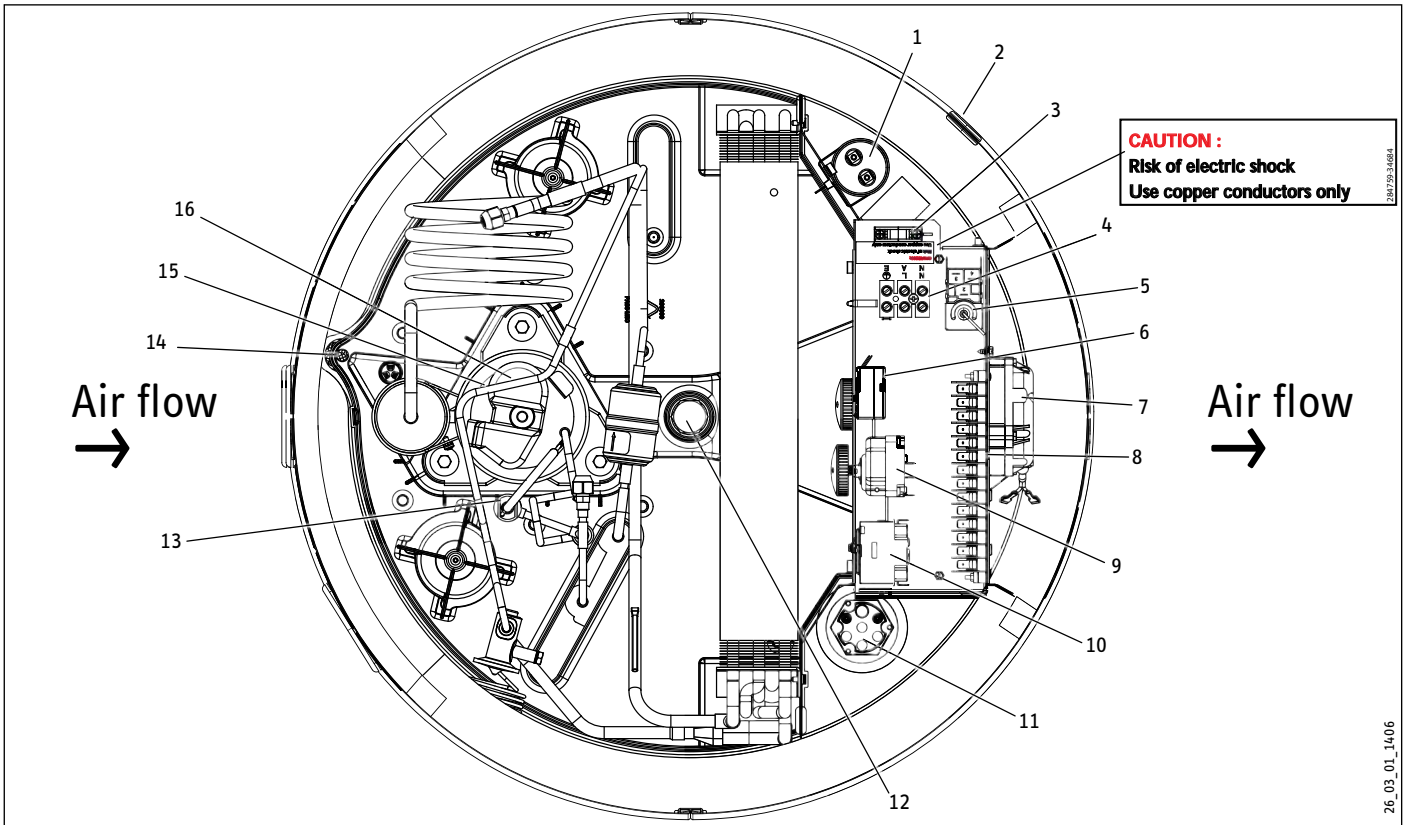

- 1 Capacitor
- 2 Cable entry into the water heater casing
- 3 Strain relief (cable clamp)
- 4 Mains terminal
- 5 Frost monitor
- 6 Heat pump control thermostat
- 7 Fan motor
- 8 Heat pump terminal
- 9 Thermostat, booster heater
- 10 High limit safety cut-out, booster heater, manual reset (see 14.1.1)
- 11 Booster heater
- 12 Sacrificial anode
- 13 Safety pressure limiter, manual reset, (see 14.1.2)
- 14 Condensate pan drain
- 15 Compressor
- 16 Compressor motor protection (Klixon), delay auto reset (see 14.1.3)

- » Pull the power cable through the cable entry into the water heater interior.
- » Route the power cable through the strain relief (cable clamp).
- » Connect the power cable to the mains terminal in accordance with the wiring diagram (see chapter 16.2 "Wiring Diagram". L1, L2 and ground).



WARNING Electric shock

Risk of injury through inadequate grounding.

- » Ensure that the water heater is correctly grounded in accordance with the requirements at the place of installation.

The ground conductor of the power cable must be connected to the terminal marked G or Earth.

10.8.1 High limit safety cut-out

At ambient temperatures below -10°C (14°F), for example during shipping or in storage, the high limit safety cut-out may trip.

Press the reset button of the high limit safety cut-out to reset it. To do this, first remove the water heater cover.

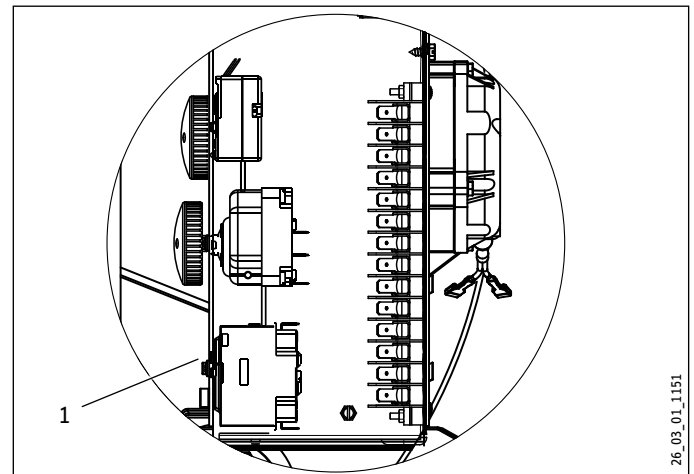

- 1 Reset button for high limit safety cut-out

INSTALLATION

INITIAL START-UP

11. Initial start-up

11.1 Initial start-up

Only approved, licensed installers may perform the initial start-up of this water heater, and instruct the user in its operation.

- » Fill and vent the water heater. For this, open the cold water supply and one hot water tap.
- » Thoroughly flush the water heater.
- » Check the safety valves. Inform the user that water may drip from the safety valve while water is being heated up.
- » Connect power by resetting the circuit breaker.



This water heater must not be operated at ambient temperatures below 6 °C (43 °F) or above 42 °C (107 °F).

11.2 Shutting down

The water heater can only be switched off by disconnecting the power supply.

11.3 Restarting

If power has been switched off or interrupted, wait 15 minutes before turning unit back on.

12. Settings

12.1 Adjusting the water temperature

The water temperature must only be adjusted by a licensed installer, as the cover must be removed from the water heater.

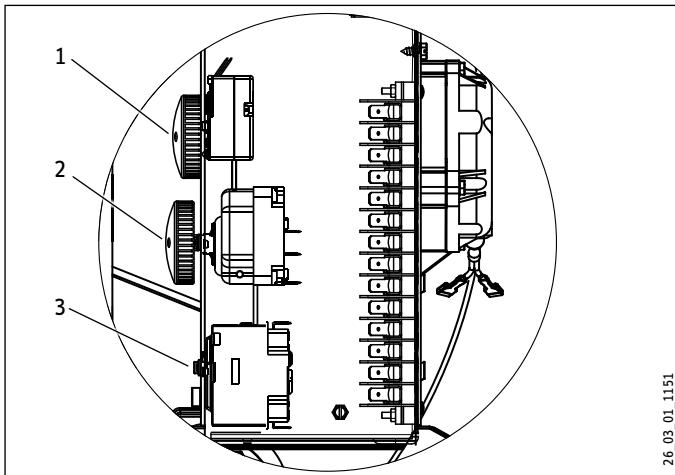

- 1 Thermostat, heat pump operation
- 2 Thermostat of the booster heater
- 3 High limit safety cutout

The temperature is reduced by turning the thermostat counter-clockwise.



Adjust both thermostats to the same setting. Energy consumption will rise if the temperature is set lower at the heat pump thermostat than at the booster heater thermostat.

Ensure that both thermostats are adjusted to the same setting.

Energy consumption will rise if the temperature is set lower at the heat pump thermostat than at the booster heater thermostat. **The booster heater must be set equal to or lower than the heat pump.**

12.2 Knob settings

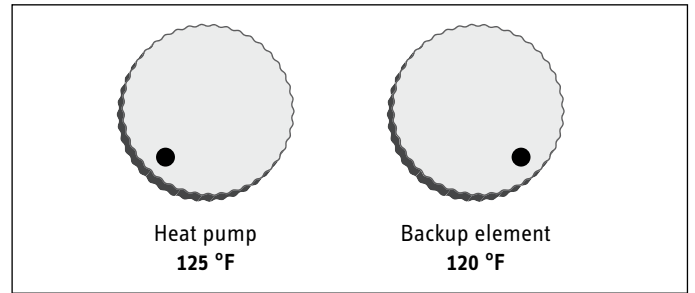

13. Water heater hand over

- » Explain the functions to the user. Draw special attention to the safety information.
- » Hand these operating instructions to the user.

14. Troubleshooting



WARNING Electric shock

Always disconnect the power supply before working on the water heater.

14.1 Safety equipment of the water heater

If faults develop, the safety cutouts on the water heater will interrupt the appropriate power circuits.

14.1.1 High limit safety cut-out for booster heater

The high limit safety cut-out protects the water heater against overheating. The booster heater is switched off when the temperature of the water inside the tank exceeds 95 °C (203 °F).

After removing the source of the fault, press the reset button on the high limit safety cut-out. To do this, first remove the water heater cover. See below.

14.1.2 Safety pressure limiter for heat pump

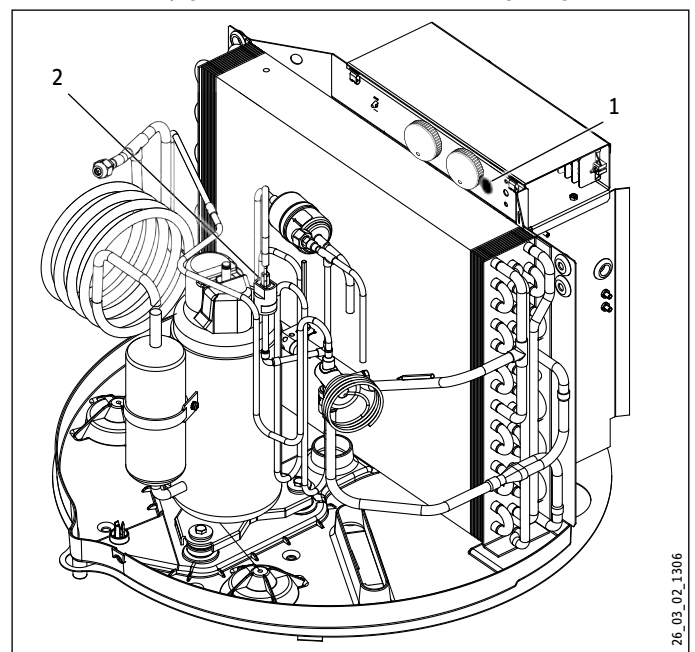

- 1 Reset button for the high limit safety cutout
- 2 Reset button for the safety pressure limiter

INSTALLATION

MAINTENANCE AND CLEANING

The safety high pressure limiter shuts down the compressor if the pressure inside the refrigerant circuit exceeds the permissible maximum value. The safety high pressure limiter may also trip if the water heater is operated above its permissible limit, i.e. above an air temperature of 42 °C (107 °F). (See above)

The safety pressure limiter also trips if the heat pump thermostat fails.

- » After the cause of the fault has been removed, reset the safety pressure limiter by pressing the reset button.

14.1.3 Protective motor switch - klixon

The protective motor switch will shut down the compressor if it is overloaded because of excessive thermal load. Remove the cause. After a short cool-down phase, the protective motor switch will restart the compressor automatically.

14.2 Troubleshooting

14.2.1 Excessive power consumption

- » Lower the temperature of the booster heater.

14.2.2 The room temperature falls excessively

One possible cause is an inadequate air flow over the evaporator.

- » Check the fan.
- » Check for clogged evaporator.
- » Ensure that the intake and discharge flow are not restricted.

15. Maintenance and cleaning

Only qualified licensed installers must carry out maintenance work in accordance with these instructions.



WARNING Electric shock

Maintenance work, such as checking the electrical safety, must only be carried out by an electrician. Always disconnect the power supply before working on the water heater.

15.1 Cleaning the evaporator



WARNING Injury

The evaporator has many sharp-edged fins. When cleaning the evaporator, proceed with caution and wear protective clothing, in particular safety gloves.

Maintaining the full output of the water heater at all times requires an occasional professional cleaning of the evaporator.

- » Undo the screws that connect the water heater cover and remove.
- » Carefully clean the evaporator fins. Only use water and a soft brush. Never use acidic or alkaline cleaning agents.

15.2 Draining the tank



WARNING Scalding

Hot water can be expelled when draining the tank.

- » Close the shut-off valve in the cold water line.
- » Fully open the hot faucets at all points.

The tank is drained via the cold water supply. Some residual water will remain in the bottom of the tank.

- » Open the drain valve (see chapter 10.7, "Water connection").

If a drain valve was not installed, undo the fitting on the cold water supply of the water heater.

15.3 Sacrificial anode rod

A sacrificial anode rod is inserted in the top of the water heater. The sacrificial anode rod fitted at the factory is approx. 1260 mm (50") long.

The timing of the anode inspection is subject to the local water quality and is determined by your local licensed installer. We recommend that the anode is checked no later than 12 months after initial start-up.

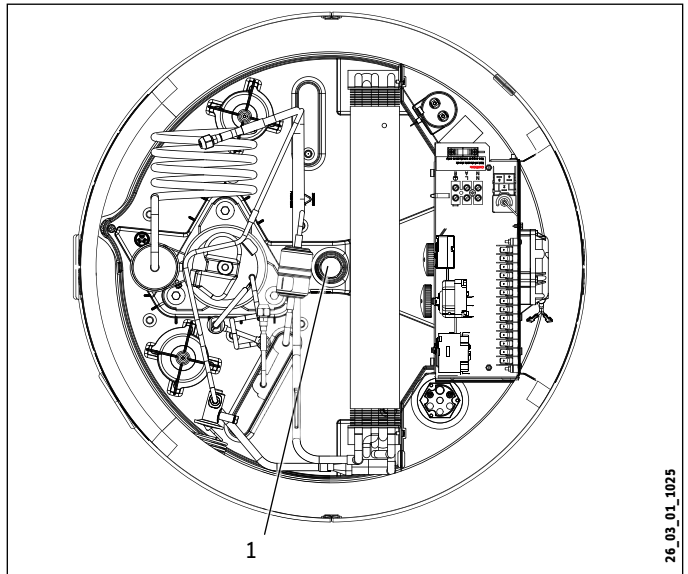

1 Sacrificial anode rod

If the anode is used up, you will need to replace it. Should it prove impossible to install an anode rod (length approx. 1260 mm (50")), install a segmented anode.

Description	Part #
Anode rod	278235
Segmented anode rod	143498

During the anode rod installation ensure a clean metal-conducting connection between the anode and the tank.

INSTALLATION

MAINTENANCE AND CLEANING

15.4 Descaling

- » Close the shut-off valve in the cold water supply to the tank.
- » Draw water from the tank to relieve the pressure inside the water heater.

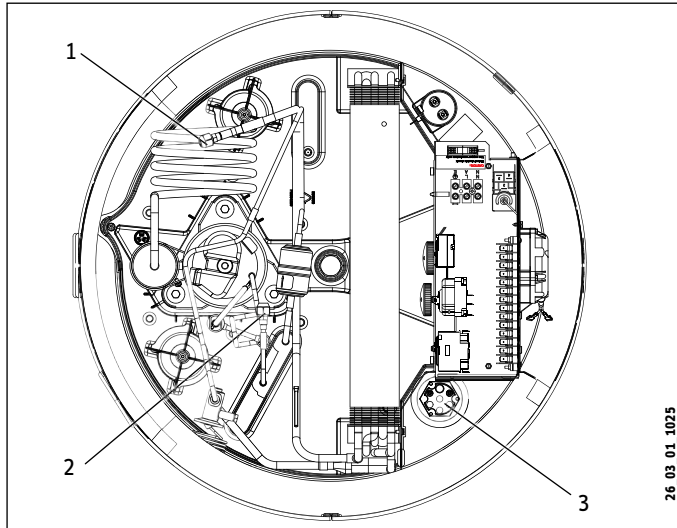

- 1 Low pressure fill port
- 2 High pressure fill port
- 3 Booster heater flange

- » Unscrew the booster heater flange and remove element.
- » Immerse scaled sections of the heater element into a descaling liquid (for example citric acid), until the limescale has dissolved.
- » Flush the descaling liquid (white vinegar is another example) off and allow the immersion heater element to dry.

15.5 Checking valves

15.5.1 Safety valve (on-site provision)

For reasons of safety, it is necessary to check the T&P valve for proper function from time to time.

- » Crack open the safety valve until a full jet of water is discharged.
- » Close the safety valve when the check is complete.

How quickly limescale builds up depends on the local water quality and the hot water temperature. As your local licensed installers are familiar with your local water quality, let them determine the timing of the next service.

15.5.2 Pressure reducing valve (on-site provision)

- » Check the on site pressure relief valve for function. If required, replace the valve.

15.5.3 Checking refrigerant levels

- » When checking refrigerant levels at fill ports be sure to use new crush washers (supplied with unit).

16. Specification

16.1 Connection and dimensions

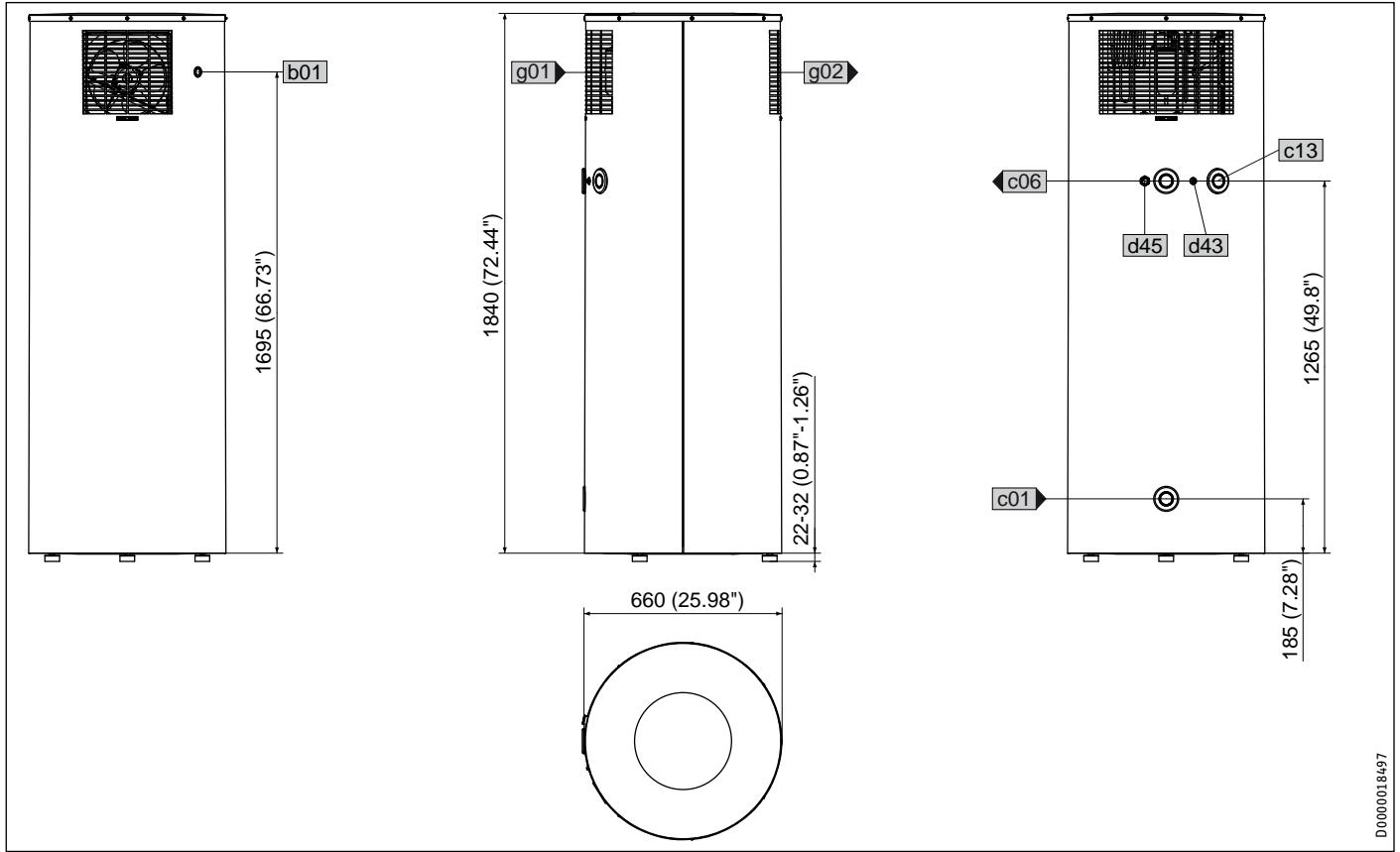

D0000018497

Accelera® 300 Connections and dimensions

b01	Entry electrical cables		
c01	Cold water inlet	Male thread	G 1
c06	DHW outlet	Male thread	G 1
c13	T&P valve	Male thread	G 3/4
d43	Condensate overflow		
d45	Condensate drain	Male thread	G 3/4
g01	Air intake		
g02	Air discharge		

16.2 Wiring diagram

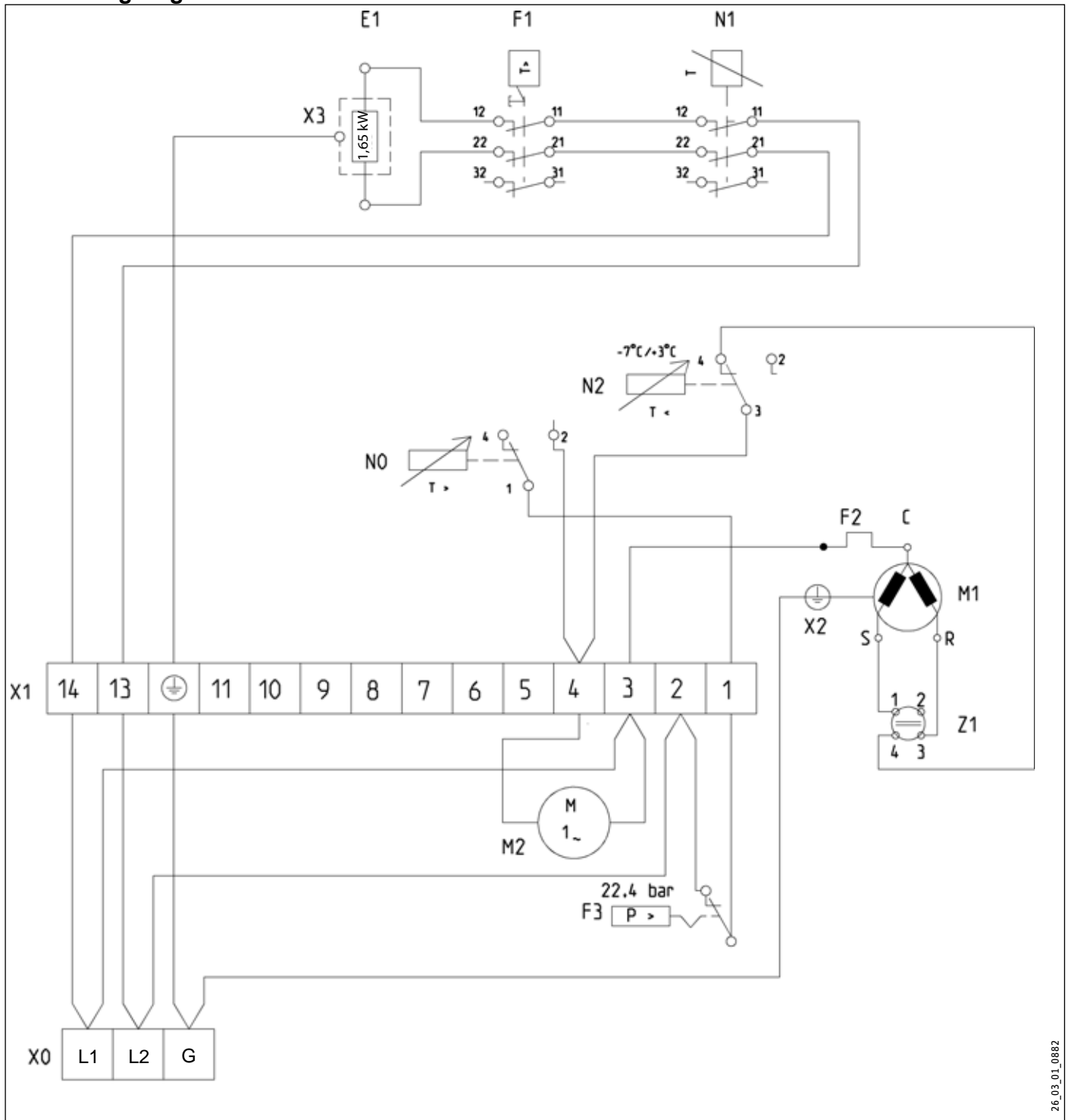

- | | | | |
|----|---|----|------------------------|
| E1 | Booster heater | X0 | Main terminal |
| F1 | High limit safety cut-out, booster heater | X1 | Heat pump terminal |
| F2 | Compressor motor protection (Klixon) | X2 | Ground, compressor |
| F3 | Safety pressure limiter (high pressure) | X3 | Ground, booster heater |
| M1 | Compressor | Z1 | Capacitor |
| M2 | Fan | | |
| N0 | Heat pump control thermostat | | |
| N1 | Thermostat - booster heater | | |
| N2 | Frost monitor | | |

ENGLISH

26.03_01_0882

16.3 Refrigerant diagram

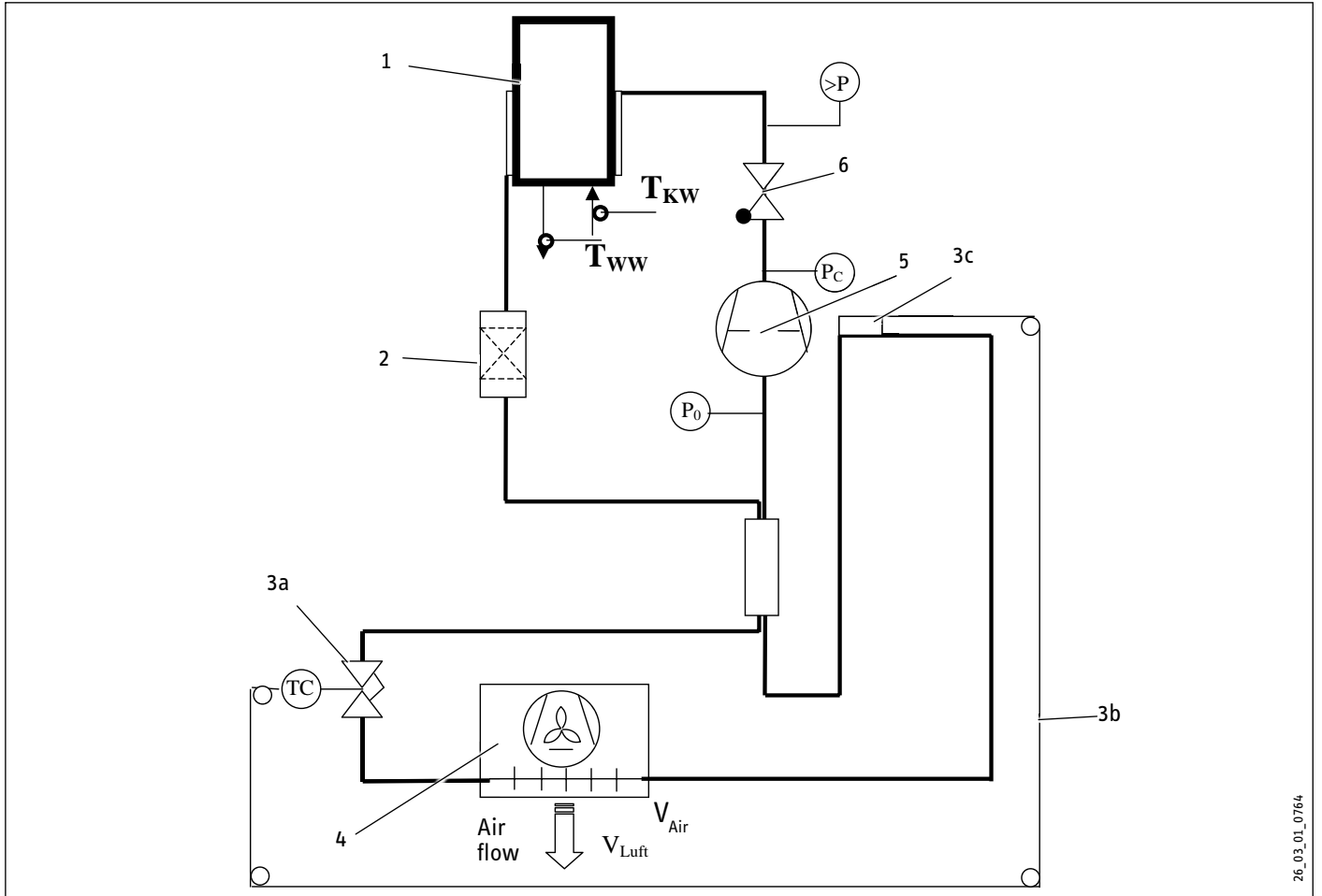

26_03_01_0764

- 1 Tank w/ heat condenser, jacket & temperature sensors
- 2 Filter dryer
- 3a Expansion valve
- 3b Capillary tube
- 3c Capillary bulb
- 4 Fan & evaporator
- 5 Compressor
- 6 Check valve
- P_C Service valve high pressure
- P_0 Service valve low pressure
- $>P$ High pressure safety switch
- TC Thermostatic expansion valve

INSTALLATION SPECIFICATION

16.4 Technical Data

Model	Heat pump water heater	
Type	Accelera 300	
Part number	222423	
Version	With passive defrosting and booster heater	
Operating details		
Lower application limit for heat pump operation (air temperature)	°C (°F)	6 (42.8)
Upper application limit for heat pump operation (air temperature)	°C (°F)	42 (107.6)
Hot water temperature, heat pump	°C (°F)	60 (140)
Hot water temperature, booster heater	°C (°F)	60 (140)
Air flow rate	m ³ /h (CFMs)	550 (324)
Tank capacity	l (Gal)	303 (80.044)
Refrigerant	R 134a	
Refrigerant / filling weight	g (oz)	900 (32)
Water heater height (minimum)	mm (inch)	1865 (73.43)
Water heater height (maximum)	mm (inch)	1903 (74.92)
Water heater diameter	mm (inch)	660 (25.98)
Dimension when tilted incl. packaging	mm (inch)	2225 (87.60)
Dimension when tilted, excl. top packaging	mm (inch)	2150 (84.65)
Dimension when tilted, excl. wooden pallet and top packaging	mm (inch)	2030 (79.92)
Dimension when tilted, excl. packaging	mm (inch)	1990 (78.35)
Weight (dry tank)	kg (lb)	130 (287)
Weight (wet)	kg (lb)	432 (950)
Water connection with adaptor	Union to 3/4"	
Condensate drain	3/4"	
Condenser	Rollbond safety heat exchanger	
Permissible operating pressure, low (cold) side*	MPa (Psi)	0.6 (87)
Permissible positive pressure, high (hot) side*	MPa (Psi)	2.4 (348.1)
Sound pressure level (spl)	dB(A)	55.2
Maximum inlet water temperature	°F (°C)	140 (60)

INSTALLATION SPECIFICATION

Model	Heat pump water heater	
Electrical details		
Power connection, voltage / frequency	L1,L2,G / 208-240 v / 60/50 Hz	
Protection	IP 24	
Maximum power consumption (Tamb = 42 °C (108 °F), Twater = 60 °C (140 °F), 240 V)	kW	2.2
Required circuit breaker size	A	15A double pole breaker
Rated power consumption, heat pump	A	2.5
Rated power consumption HP (in accordance with DIN 8947, at 15 °C (59 °F) air temperature, 70% relative humidity and 45 °C (113 °F)water temperature)	kW	0.5
Power consumption, booster heater	kW	1.690
Heating output HP (at 15 °C (59 °F) air temperature, 70% relative humidity, water heat-up from 15 °C (59 °F) to 60 °C (140 °F), in accordance with EN 255 T3, 240 V / 60 Hz)	kW	approx. 1.7
Coefficient of Performance (COP) (t) (at 15 °C (59 °F) air temperature, 70% relative humidity, water heat-up from 15 °C (59 °F) to 60 °C (140 °F), in accordance with EN 255 T3, 240 V / 60 Hz)	3.18	

* Standard automotive R-12/R-134A manifold gauge set can be used to test and fill refrigerant.

WARRANTY

Stiebel eltron warrants to the original owner that the Accelera® 300 heat pump water heater will be free from defects in workmanship and materials for a period of ten (10) years from the date of purchase.

Should the part(s) prove to be defective under normal use during this period, Stiebel Eltron, Inc. will be responsible for replacement of the defective part(s) only. Stiebel Eltron, Inc. will not be liable for any costs of transportation, removal, reinstallation, or any other labor or freight charges that may arise in connection with a warranty claim or any incidental or consequential expenses.

This warranty does not apply:

1. To conditions resulting from a failed component or part that is not part of the heat pump Water heater
2. To freeze damage
3. To conditions resulting from misuse, abuse, neglect, accident, or alteration
4. To conditions resulting from the introduction of harmful chemicals, caustic fluids, or liquids deleterious to copper tubing, including improperly applied or maintained heat transfer fluids
5. To excessive pressure
6. To conditions resulting from floods, earthquakes, winds, fire, lightning, or circumstances beyond the manufacturer's control
7. To installation methods which do not conform to relevant national, state or local codes and ordinances, good industry practices or applicable manuals, diagrams, technical bulletins or written installation instructions; and, to applications other than medium temperature.

To obtain service under this warranty, the owner must first secure written authorization from stiebel eltron, inc. The owner shall be required to show proof of purchase date, and to pay all transportation costs to return the defective part(s) for repair or replacement.

Environment and recycling

Please help us protect the environment. Dispose of the appliance and its packaging in accordance with national regulations.

KYOTO | R134a

This device is filled with refrigerant R134a.

Refrigerant R134a is a CFC greenhouse gas mentioned in the Kyoto protocol with a global greenhouse potential (GWP) = 1300.

Never release refrigerant R134a to atmosphere.

North, Central, and South America

United States of America

STIEBEL ELTRON, Inc.

17 West Street | West Hatfield, MA 01088

Tel. 0413 247-3380 | Fax 0413 247-3369

Email info@stiebel-eltron-usa.com

Web www.stiebel-eltron-usa.com



Subject to errors and technical changes.

Stand 8643

STIEBEL ELTRON

A 280011-36705-8737