

MINIPURE[®]

ULTRAVIOLET WATER PURIFIERS

Models	Ballast 120v 50/60 Hz	Ballast 230v 50/60Hz
MIN-6	10-0015B	10-0504A



Installation, Operation & Maintenance

ATLANTIC  **ULTRAVIOLET**
CORPORATION[®]

375 Marcus Boulevard • Hauppauge, NY 11788 • USA
631.273.0500 • Fax: 631.273.0771
e-mail: info@ultraviolet.com

Extensive Product Information Available at:

www.ultraviolet.com

Owner's Manual

TABLE OF CONTENTS

SAFETY WARNINGS	3
SAFETY INSTRUCTIONS	3
PRODUCT APPLICATION	4
CONSTRUCTION	4
PRINCIPLE OF OPERATION	4
LIMITATION OF USE	4
WATER QUALITY	4
INSTALLATION	5
LOCATION.....	5
DIMENSIONAL DATA	6
RECOMMENDED INSTALLATION	7
INSTALLATION: MIN-6 120v 50/60Hz (BALLAST NO.10-0015B)	8
INSTALLATION: MIN-6 230v 50/60Hz (BALLAST NO.10-0504A)	9-11
<i>GROUNDING KIT INSTALLATION: MIN-6 230v 50/60Hz (BALLAST NO.10-0504A)</i>	10-11
<i>TOOLS REQUIRED</i>	10
<i>COMPLETED GROUNDING KIT INSTALLATION</i>	11
RECOMMENDED OPTIONS.....	12
MAINTENANCE	12
INSPECTION	12
LAMP INSTALLATION OR REPLACEMENT: MIN-6 120v 50/60Hz (BALLAST NO.10-0015B)	13
LAMP INSTALLATION OR REPLACEMENT: MIN-6 230v 50/60Hz (BALLAST NO.10-0504A)	14
QUARTZ SLEEVE CLEANING OR REPLACEMENT.....	15
REPLACEMENT OF BROKEN QUARTZ SLEEVE	16
DISPOSAL OF MERCURY ADDED LAMP.....	16
TROUBLESHOOTING	17
TECHNICAL SPECIFICATIONS	18
REPLACEMENT PARTS	19
USER ASSISTANCE	20
WARRANTY	20
PATENT NOTICE.....	20

These instructions generally describe the installation, operation and maintenance of the **MINIPURE®** Model MIN-6. Questions that are not specifically answered by these instructions should be directed to the Factory.

Atlantic Ultraviolet Corporation takes all possible precautions when packaging equipment to prevent damage. Carefully inspect and report all damage upon receipt of product. Do not install damaged equipment.

Follow all instructions on all labels and tags. Carefully inspect all packing materials before discarding to prevent the loss of accessories, mounting hardware, spare parts or instructions.

The information and recommendations contained in this publication are based upon data collected by the Atlantic Ultraviolet Corporation® and are believed to be correct. However, no guarantee or warranty of any kind, expressed or implied, is made with respect to the information contained herein. Specifications and information are subject to change without notice.



SAFETY WARNINGS

- All personnel should be alerted to the potential hazards indicated by the product safety labeling on this unit.
- The following conventions are used to indicate and classify precautions in this manual and on product safety labeling. Failure to observe precautions could result in injury to people or damage to property.



This is the safety alert symbol. It is used to alert you to potential personal injury hazards. Obey all safety messages that follow this symbol to avoid possible injury or death.

DANGER

Danger indicates an **IMMINENTLY** hazardous situation, which, if not avoided, **WILL** result in death or serious injury.

WARNING

Warning indicates a **POTENTIALLY** hazardous situation, which, if not avoided, **COULD** result in death or serious injury.

CAUTION

Caution indicates a **POTENTIALLY** hazardous situation, which, if not avoided, **MAY** result in minor or moderate injury.

CAUTION

Caution used without the safety alert symbol indicates a potentially hazardous situation, which, if not avoided, may result in property damage.



This symbol/pictorial is used to identify an **ELECTRICAL SHOCK** or **ELECTROCUTION** hazard.





This symbol/pictorial is used to identify an **ULTRAVIOLET LIGHT** hazard.

- Product safety labels should be periodically inspected and cleaned, as necessary, to maintain good legibility. Always replace illegible safety labels. Contact factory to obtain replacement safety labels.

SAFETY INSTRUCTIONS

 WARNING: To guard against injury, basic safety precautions should be observed, including the following:

1. Read and follow ALL safety instructions.
2. Do not use this water purifier for other than its intended purpose as described in this manual.
3. Do not alter design or construction.
4. Do not remove any labels or devices.
5. ** DANGER:** To prevent the risk of severe or fatal electrical shock, special precautions must be taken since water is present near electrical equipment. Always disconnect power before performing any service or maintenance.
6. ** WARNING:** Avoid exposure to direct or strongly reflected germicidal ultraviolet rays. Germicidal ultraviolet rays are harmful to the eyes and skin.
7. Intended for indoor use only. The water purifier should be protected from the elements and from temperatures below freezing.
8. Do not operate water purifier if lamp cable, lamp connection, power cord and/or plug are damaged, or if any other damage to the water purifier is visible or suspected.
9. Electrical power supplied, to the water purifier, **MUST** match power requirements listed on the water purifier.
10. Plug the water purifier into an approved ground fault circuit interrupt (GFCI) receptacle.
11. ** CAUTION:** Do not operate without proper electrical ground.
12. Do not exceed water purifier's maximum rated flow capacity.
13. Do not exceed maximum operating pressure of 100 PSI.
14. Read and follow all notices and warnings on the water purifier.
15. **SAVE THESE INSTRUCTIONS.**

PRODUCT APPLICATION

CONSTRUCTION

- The water purifier is designed to mount horizontally.
- The water purifier chamber is passivated and electropolished Stainless Steel Type 304.
- Easy-off end caps allow for quick and easy lamp change, without disconnecting from the water supply or draining the purifier. No tools are required.

PRINCIPLE OF OPERATION

The MINIPURE® design has been carefully conceived to provide adequate germicidal dosage throughout the disinfection chamber. The dosage, as it applies to ultraviolet disinfection, is a function of time and the intensity of ultraviolet radiation to which the water is exposed. The exposure time, in seconds, is the total time it takes the water to flow through the disinfection chamber exposing it to the germicidal lamp. Exposure time is related to the flow rate; the higher the flow rate, the lower the exposure time or the lower the flow rate, the higher the exposure time. The ultraviolet intensity is the amount of energy, per unit time, emitted by the germicidal lamp. The dosage is the product of ultraviolet intensity and the exposure time. The operation of the MINIPURE® is as follows:

1. Water enters the purifier and flows into the annular space between the quartz sleeve and the chamber wall.
2. Suspended microorganisms are exposed to the ultraviolet rays emitted by the germicidal lamp.
3. The LED indicator light, located on the ballast, provides visual indication of germicidal lamp operation.
4. Water leaving the purifier is instantly ready for use, no further contact time is required.

LIMITATION OF USE

The water purifier is intended for the use with visually clear water, not colored, cloudy or turbid.

See “Water Quality” section below.

The water purifier is **NOT** intended for the treatment of water that has an obvious contamination or intentional source, such as raw sewage; nor is the unit intended to convert wastewater to microbiologically safe drinking water.

WATER QUALITY

Water quality plays a major role in the transmission of germicidal ultraviolet rays. It is recommended that the water does not exceed the following maximum concentration levels:

Table 1 - Maximum Concentration Levels

Turbidity:	5 NTU
Manganese:	0.05mg/l
Total Suspended Solids:	10 mg/l
pH:	6.5 - 9.5
Color:	None
Hardness:	6 GPG or 102.6 PPM
Iron:	0.3 mg/l

Effectively treating water with higher concentration levels than listed above can be accomplished, but may require added measures to improve water quality to treatable levels. If, for any reason, it is believed the ultraviolet transmission is not satisfactory, contact the factory.

INSTALLATION

LOCATION RECOMMENDATION

1. The water purifier is intended for indoor use only. The water purifier should be protected from the elements and from temperatures below freezing. The ambient temperature, in the area surrounding the water purifier, should be between 33° F and 100° F.
2. Electrical power supplied to the water purifier **MUST** match power requirements listed on the water purifier. Use of a voltage surge protector is recommended.
3. **CAUTION:** Install water purifier within 48" of a known good ground. Water Purifier will need to be installed into approved ground fault circuit interrupt (GFCI) receptacle. Where a 2-prong or unprotected 3-prong receptacle is encountered, it must be replaced by a properly grounded Ground Fault Circuit Interrupt (GFCI) receptacle. Installation must be in accordance with the National Electrical Code and any local codes and ordinances by a qualified electrician.
4. The water purifier should be located in a dry, well-lit area, which provides enough room to perform routine maintenance. This includes a minimum distance of one chamber length from the chamber end, to allow for cleaning and/or the changing of the lamp and quartz sleeve as well as a minimum of 6" on the opposite end of the water purifier. See "**DIMENSIONAL DATA**" section.
5. The water purifier should always be located closest to the point of use. This reduces the chance of the purified water being re-contaminated by bacteria in the water distribution system after the water purifier.
6. **CAUTION:** As with any water handling device, the water purifier should be located in an area where any possible condensation or leakage from the water purifier, any purifier accessory and/or plumbing will not result in damage to the area surrounding the water purifier. For added protection, it is recommended that a suitable drain pan be installed under the purifier. The drain pan must be plumbed to an adequate, free flowing, drain to prevent water damage in the event of a leak. There are numerous leak detection/flood stop devices, available on the market today, designed to stop the flow of water, reducing the chance of water damage due to leakage. For more details regarding leak prevention and/or limiting damages due to leaks, please contact the factory.
7. The water purifier should be located after all other water devices, such as De-ionizers, Water Softeners, Carbon Filters, Pre-Filters, Reverse Osmosis, Pressure Tanks, and Pumps. This reduces the chance of the purified water being re-contaminated by bacteria in any of these units.
8. For 230v 50/60Hz water purifiers using ballast no.10-0504A, use Grounding Kit supplied (part no. 35-8300A). See **Figure 1- Grounding Kit** below.
9. We recommend checking with local codes or a licensed electrician in your area to determine the best grounding point to attach the ground kit for your installation. Once a proper ground point has been determined, see "**GROUNDING KIT INSTALLATION: MIN-6 230V 50/60HZ (BALLAST NO.10-0504A)**" in the "**INSTALLATION**" section.

Figure 1 - Grounding Kit (35-8300A)



DIMENSIONAL DATA

Figure 2 - MIN-6 Dimensional Drawing

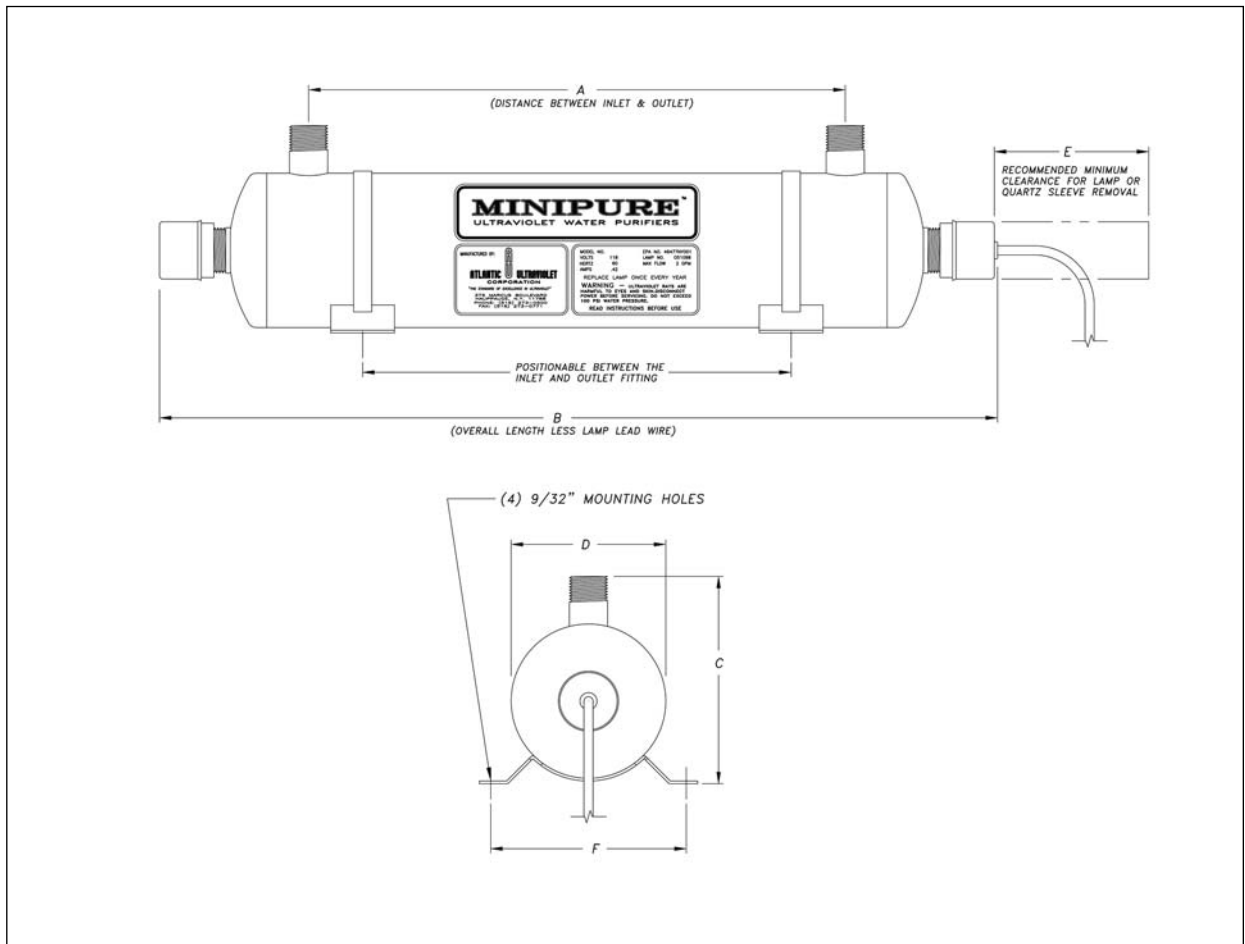

Table 2 - MIN-6 Dimensional Data

A	B	C	D	E	F	Inlet/Outlet
14- ³ / ₄ "	22- ¹⁷ / ₃₂ "	5- ³ / ₄ "	4- ¹ / ₄ "	22"	5- ³ / ₈ "	³ / ₄ "MNPT

All specifications, dimensional data, etc are approximate and subject to change without notice.

RECOMMENDED INSTALLATION

Figure 3 - Recommended Installation

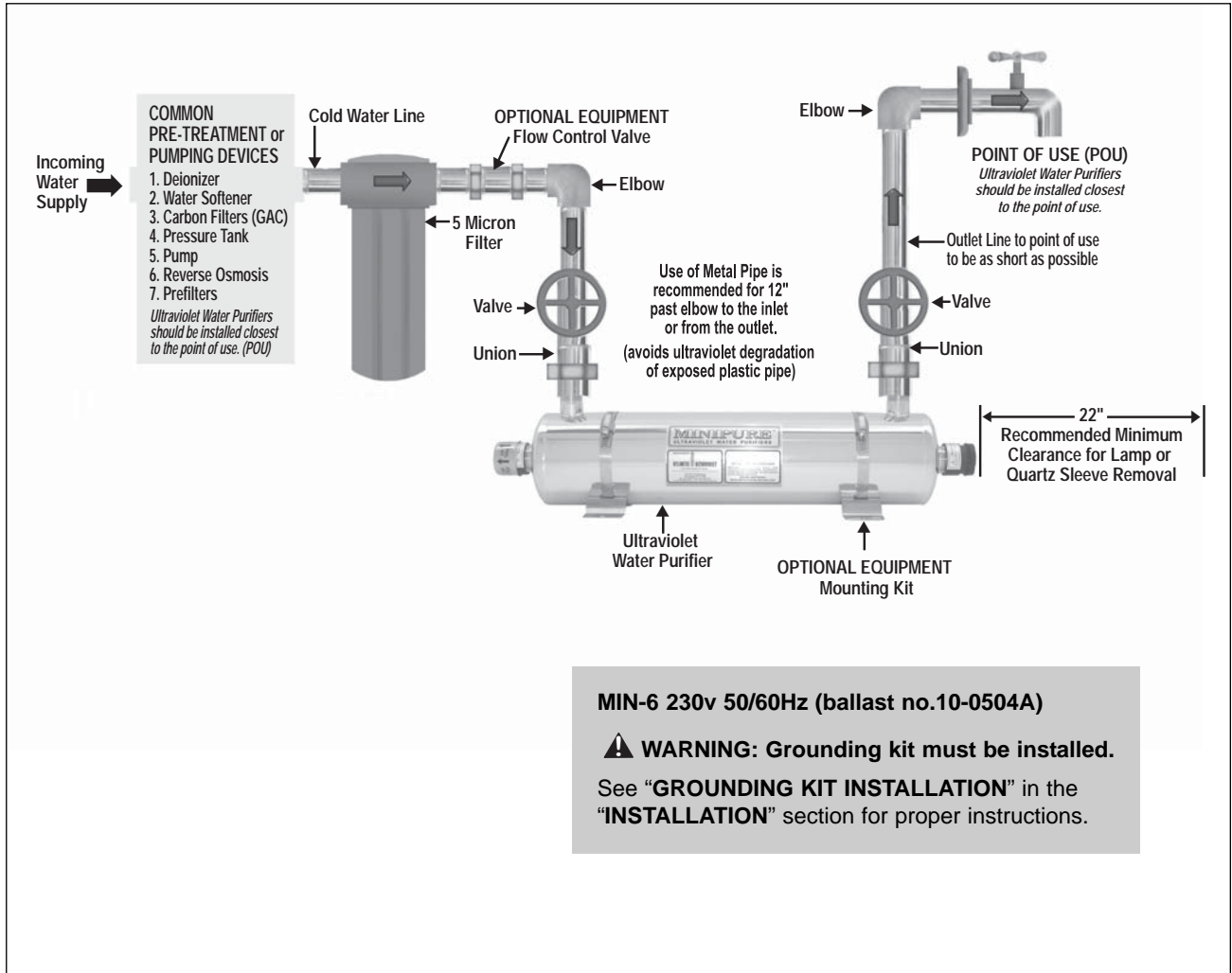

MIN-6 230v 50/60Hz (ballast no.10-0504A)

⚠ WARNING: Grounding kit must be installed.

See "GROUNDING KIT INSTALLATION" in the "INSTALLATION" section for proper instructions.

INSTALLATION: MIN-6 120v 50/60HZ USING BALLAST NO.10-0015B

1. Remove water purifier from shipping carton. Inspect water purifier, power cord and plug for damage. Do not operate if there is any damage to the purifier, power cord or plug. All models, of the **MINIPURE®** line of water purifiers, are shipped with the lamps packed separately. Keep the lamp aside for installation once the purifier has been properly installed.
2. Units occasionally experience damage in shipment due to the fragility of the quartz sleeve. It is therefore recommended to inspect the water purifier for damage to the quartz sleeve after it has been removed from the shipping carton. Each end of the unit as well as the inlet and outlet should be viewed to see if the quartz sleeve has experienced damage. If the quartz sleeve shows signs of damage it should be replaced before the purifier is pressurized. See “**QUARTZ SLEEVE CLEANING OR REPLACEMENT**” in the “**MAINTENANCE**” section for the proper method of replacing the quartz sleeve in your water purifier.
3. The water purifier should be mounted horizontally on a flat dry surface. The purifier should not be solely supported by its plumbing connections. Securing the water purifier using the optional wall universal bracket kit is recommended.
4. The water purifier must be connected to the cold water line only.
5. It is recommended that a 5-micron sediment filter be installed, in line, prior to the water purifier. The sediment filter will stop or trap any particulates from entering the water purifier. Particulates may cause damage to the quartz sleeve, as well as interfere with the purifier’s ability to disinfect the water. The sediment filter may also help to reduce the amount of routine cleanings of the quartz sleeve.
6. Shut off valves should be installed on both the inlet and outlet sides of the water purifier. **The use of bypass valves is not recommended.** The shut off valves allow the purifier to be isolated from the water supply, which is required when removing the quartz sleeve.
7. Unions should be installed on both the inlet and outlet of the water purifier; this will allow easy removal of the water purifier from the plumbing, if required. Apply Teflon® tape to threads of inlet and outlet ports to ensure a tight seal.
8. When all plumbing connections are complete, allow water to enter the water purifier at a low flow rate, until the purifier is pressurized. With the purifier pressurized, it should be checked for leaks. Once it is determined that there are no leaks, the inlet valve can be fully opened.

Figure 4 - 120v 50/60Hz (ballast no. 10-0015B)

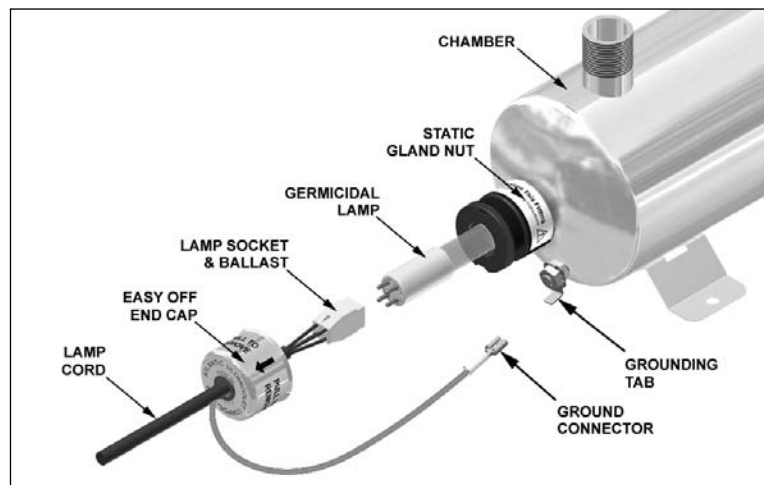

9. Unpack the lamp and ballast. While holding lamp end, carefully push lamp socket on. Carefully slide lamp straight into the quartz sleeve, without angling. Push the end cap on, over the static gland nut. Attach the ground connector to the grounding tab of the chamber

▲ CAUTION: Lamp and quartz sleeve are easily damaged. Exercise care when handling.

10. Plug ballast into an approved Ground Fault Circuit Interrupt (GFCI) receptacle. Where a 2-prong or unprotected 3-prong receptacle is encountered, it must be replaced by a properly grounded Ground Fault Circuit Interrupt (GFCI) receptacle. Installation must be in accordance with the National Electrical Code and any local codes and ordinances by a qualified Electrician.
11. Once the plumbing hook ups are made, it is a good practice to disinfect the “downstream” plumbing. This is done by introducing chlorine or other disinfectant solution directly into the purifier chamber, a 100-ppm of chlorine is suggested. With the disinfectant solution in the purifier chamber, turn the ultraviolet purifier on. Open the “downstream” outlet until a chlorine odor is noticed. Close the outlet and allow the disinfectant to remain in the plumbing for at least three (3) hours. Flush the plumbing with ultraviolet purified water; allow the water to run for several minutes before use, this will allow the ultraviolet lamp to reach its full germicidal output.

INSTALLATION: MIN-6 230v 50/60HZ USING BALLAST NO.10-0504A

1. Remove water purifier from shipping carton. Inspect water purifier, power cord and plug for damage. Do not operate if there is any damage to the purifier, power cord or plug. All models, of the **MINIPURE®** line of water purifiers, are shipped with the lamps packed separately. Keep the lamp aside for installation once the purifier has been properly installed.
2. Units occasionally experience damage in shipment due to the fragility of the quartz sleeve. It is therefore recommended to inspect the water purifier for damage to the quartz sleeve after it has been removed from the shipping carton. Each end of the unit as well as the inlet and outlet should be viewed to see if the quartz sleeve has experienced damage. If the quartz sleeve shows signs of damage it should be replaced before the purifier is pressurized. See “**QUARTZ SLEEVE CLEANING OR REPLACEMENT**” in the “**MAINTENANCE**” section for the proper method of replacing the quartz sleeve in your water purifier.
3. The water purifier should be mounted horizontally on a flat dry surface. The purifier should not be solely supported by its plumbing connections. Securing the water purifier using the optional wall universal bracket kit is recommended.
4. The water purifier must be connected to the cold water line only.
5. It is recommended that a 5-micron sediment filter be installed, in line, prior to the water purifier. The sediment filter will stop or trap any particulates from entering the water purifier. Particulates may cause damage to the quartz sleeve, as well as interfere with the purifier’s ability to disinfect the water. The sediment filter may also help to reduce the amount of routine cleanings of the quartz sleeve.
6. Shut off valves should be installed on both the inlet and outlet sides of the water purifier. **The use of bypass valves is not recommended.** The shut off valves allow the purifier to be isolated from the water supply, which is required when removing the quartz sleeve.
7. Unions should be installed on both the inlet and outlet of the water purifier; this will allow easy removal of the water purifier from the plumbing, if required. Apply Teflon® tape to threads of inlet and outlet ports to ensure a tight seal.
8. When all plumbing connections are complete, allow water to enter the water purifier at a low flow rate, until the purifier is pressurized. With the purifier pressurized, it should be checked for leaks. Once it is determined that there are no leaks, the inlet valve can be fully opened.

Figure 5 - 230v 50/60Hz (ballast no. 10-0504A)

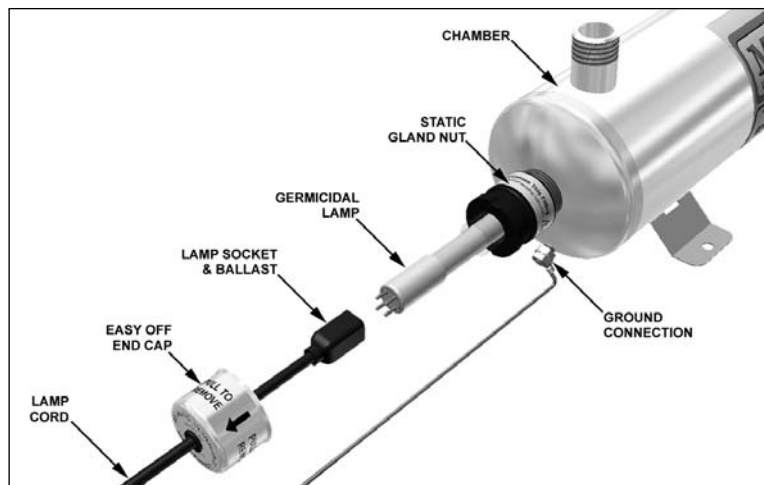

9. Unpack the lamp and ballast. While holding lamp end, carefully push lamp socket on. Carefully slide lamp straight into the quartz sleeve, without angling. Push the end cap on, over the static gland nut.

▲ CAUTION: Lamp and quartz sleeve are easily damaged. Exercise care when handling.

INSTALLATION: MIN-6 230V 50/60HZ (BALLAST NO.10-0504A)
CONTINUED ON PAGES 10 AND 11

GROUNDING KIT INSTALLATION: MIN-6 230v 50/60Hz USING BALLAST NO.10-0504A

10. Ground Kits are shipped with each MINIPURE Model MIN-6 230v 50/60Hz water purifier using ballast 10-0504A and is used to permanently connect a ground wire from the water purifier chamber to a known good ground.

We recommend checking with local codes or a licensed electrician in your area to determine the best grounding point to attach the ground kit for your installation. An electrician can also measure the resistance between the water pipe and an electrical outlet ground to insure your ground selection is correct.

PLACEMENT: Select a location that is visible as well as accessible. Connect the ground strap to a known good ground or a water pipe that is metallic, with no intervening plastic fittings between it and the power ground.

INSTALLATION: Once a proper ground point has been determined, fasten the ground to the water purifier chamber as shown and described below.

If you receive a 230v 50/60Hz water purifier, or ballast for a water purifier using ballast no. 10-0504A and a grounding kit is not present in the carton please contact the factory with your order information and we will send you the correct grounding kit for your application.

TOOLS REQUIRED

- 7/16" Wrench
- 10mm Wrench or Universal Pliers
- Continuity Tester

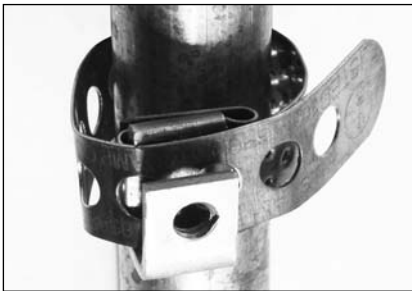

Step 11 - Wrap Strap Tight Around Pipe



Step 12 - Insert Bolt Through Both Copper Holes & Tighten using a 7/16" Wrench

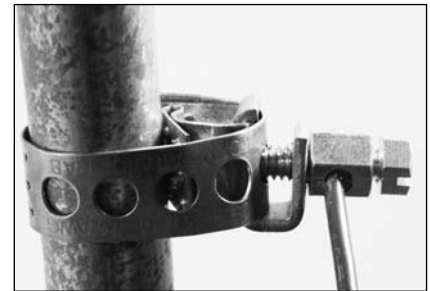

Step 13
• Insert Wire Into Hole & Install Bolt
• Tighten Bolt against Wire using 10mm Wrench, Ensure all is Secure



Step 14 - Install Nut on Stud



Step 15 - Slide Ring Terminal Wire Assembly onto Stud & Lock Washer over Ring



Step 16 - Install Nut on Stud against Washer & Tighten with 7/16" Wrench

⚠ WARNING: To insure proper operation and safety of your water purifier, your unit must be grounded to a known good ground.

GROUNDING KIT INSTALLATION: MIN-6 230V 50/60HZ USING BALLAST NO.10-0504A (CONTINUED)

11. Wrap the copper strap tight around the pipe or metal grounding rod with the sharp edges of the strap facing towards the item.
12. While keeping the strap tightly around the pipe or metal ground, align one of the holes in the strap with the long threaded bolt, and tighten using a 7/16" wrench.
(Note: As you continue to tighten the long threaded bolt it begins to press against the end of the grounding strap & tighten the grip around the pipe or metal ground)
13. Next, insert the bare copper wire into the eye hole in the long threaded bolt, and using a 10mm wrench or universal pliers tighten the small bolt down onto the copper wire. Ensure that the strap is securely fastened to the pipe and that the copper wire is in contact with the small bolt.
14. Install one nut supplied in grounding kit on stud of water purifier chamber.
15. Take ring terminal wire assembly and slide onto stud. Slide lock washer over ring terminal.
16. Place other nut so that ring terminal and lock washer are between two nuts. Tighten nuts against each other using a 7/16" wrench.
17. Using a Continuity Tester insure that continuity exists between the water purifier chamber and the pipe or metal ground.

Once completed the ground should appear as shown below.

Figure 6 - Completed Ground



18. Plug ballast into an approved Ground Fault Circuit Interrupt (GFCI) receptacle. Where a 2-prong or unprotected 3-prong receptacle is encountered, it must be replaced by a properly grounded Ground Fault Circuit Interrupt (GFCI) receptacle. Installation must be in accordance with the National Electrical Code and any local codes and ordinances by a qualified electrician.
19. Once the plumbing hook ups are made, it is a good practice to disinfect the “downstream” plumbing. This is done by introducing chlorine or other disinfectant solution directly into the purifier chamber, a 100-ppm of chlorine is suggested. With the disinfectant solution in the purifier chamber, turn the ultraviolet purifier on. Open the “downstream” outlet until a chlorine odor is noticed. Close the outlet and allow the disinfectant to remain in the plumbing for at least three (3) hours. Flush the plumbing with ultraviolet purified water; allow the water to run for several minutes before use, this will allow the ultraviolet lamp to reach its full germicidal output.

RECOMMENDED OPTIONS

1. **Sentry™ Safety Sensor:** Pilot lamps provide constant visual monitoring of normal operation. In the event of ballast or lamp failure the safety sensor indicates an alarm condition. The safety sensor is capable of operating an optional audio alarm and/or solenoid valve.
2. **Audio Alarm:** Activated by the Safety Sensor, alerts the user to any malfunction detected.
3. **Time Delay Mechanism:** Provides a 2-minute warm up period during which the ultraviolet lamp achieves its full germicidal output before the water is allowed to flow through the water purifier. The time delay mechanism is used in conjunction with, and is electrically connected to the Solenoid Valve.
4. **Solenoid Valve (Nylon /Brass 3/4" NPT):** Operated in conjunction with the Safety Sensor or Time Delay Mechanism, this valve prevents water flow through the water purifier when an abnormal condition is detected or in the event of power failure.

Solenoid Valve - Nylon 3/4" NPT - Valve requires 10-PSI pressure drop for satisfactory operation.

5. **SureFLO™:** Flow Control Valve, limits water flow to the rated capacity of the purifier. The flow control valve is located in line prior to the water purifier, and should be protected from ultraviolet exposure by the use of a 90-degree elbow fitting between the flow control valve and the water purifier.
Unless otherwise specified PVC flow control valves are supplied. Stainless Steel Flow Control Valves are available for certain models. All PVC and Stainless Steel flow control valves are male NPT Consult Factory for other flow control valves.
6. **Elapsed Time Indicator:** A non-resettable display of the water purifier operating hours. Useful for scheduling and recording maintenance and lamp replacement.

MAINTENANCE

The water purifier is designed to operate with a minimal amount of maintenance, providing the water quality does not exceed maximum concentration levels, see “**WATER QUALITY**” in the “**PRODUCT APPLICATION**” section.

Ordinary maintenance consists of;

- Lamp replacement is recommended every 10,000 hours of operation, approximately 12 months of continuous service.
- Cleaning of the quartz sleeve, when conditions warrant.
- If water purifier is not going to be used for an extended period of time and temperature surrounding the purifier will be below 33° F, completely drain water purifier and disconnect water supply and power.

INSPECTION

1. Regularly inspect the water purifier to ensure that the germicidal lamp is still in operation.
 - An LED indicator light, located on the ballast, provides visual indication of germicidal lamp operation. This provides an indication of lamp operation and does not indicate the level of ultraviolet intensity or transmission through the water.
 - 230v 50/60Hz Ballast (Part no. 10-0504A) has a built-in audio alarm which will indicate lamp failure.
 - On purifiers so equipped, the **Sentry™** Safety Sensor provides visual indication of ballast and ultraviolet lamp operation.
2. To ensure proper operation of the water purifier, regular biological testing should be performed on a schedule recommended by local public health authorities, or at minimum; at installation, quarterly for the first year of service and annually, at lamp replacement, for the life of the water purifier.
3. As with any water purifier installation, routine maintenance is necessary to insure your equipment is operating correctly. Regular inspection must also include the inspection of the ground to insure grounding wires are secure to both the water purifier and grounding point as originally installed. Any components which are damaged, or broken should be replaced.

LAMP INSTALLATION OR REPLACEMENT: MIN-6 120v 50/60Hz USING BALLAST NO.10-0015B

Figure 7 - Lamp Replacement for Model MIN-6 120v 50/60Hz (ballast no. 10-0015B)

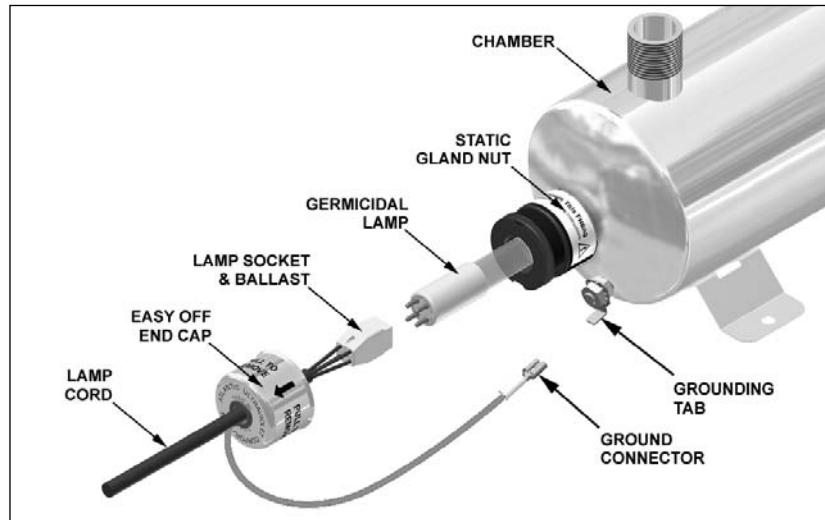

Step 1 - Disconnect Power to Water Purifier and Remove Ground Connector



Step 2 - Remove End-Cap

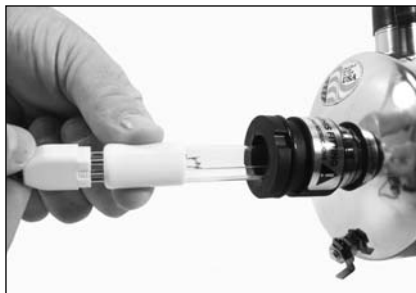

Step 3 - Remove Socket



Step 4 - Remove Lamp

1. **Disconnect power to water purifier, and remove ground connector from the chamber.**
2. Remove easy-off end cap by pulling cap off static gland nut.
3. Pull lamp cord and carefully withdraw lamp approximately 2 inches from chamber. While holding lamp end, remove lamp socket from exposed lamp end.
4. Carefully withdraw lamp from chamber. Be sure to withdraw lamp straight out without angling until completely clear of quartz sleeve.

⚠ CAUTION: Lamp and quartz sleeve are easily damaged. Exercise care when handling.

5. Reinstall lamp in reverse order.

⚠ WARNING: Germicidal ultraviolet rays are harmful to eyes and skin. Do not restore power to water purifier until lamp and easy-off end caps have been properly reinstalled.

LAMP INSTALLATION OR REPLACEMENT: MIN-6 230v 50/60Hz USING BALLAST NO.10-0504A

Figure 8 - Lamp Replacement for Model MIN-6 230v 50/60Hz (ballast no. 10-0504A)

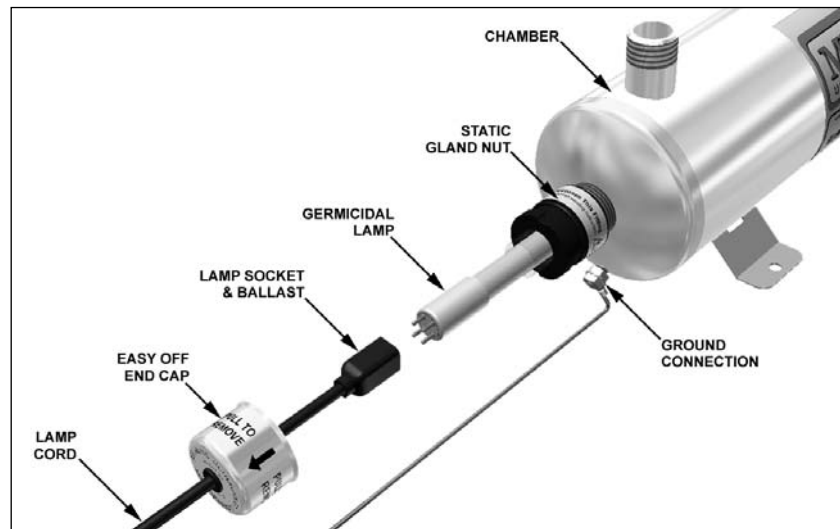

Disconnect Power

Step 1 - Disconnect Power



Step 2 - Remove End-Cap



Step 3 - Remove Socket



Step 4 - Remove Lamp

1. **Disconnect power to water purifier.**
2. Remove easy-off end cap by pulling cap off static gland nut.
3. Pull lamp cord and carefully withdraw lamp approximately 2 inches from chamber. While holding lamp end, remove lamp socket from exposed lamp end.
4. Carefully withdraw lamp from chamber. Be sure to withdraw lamp straight out without angling until completely clear of quartz sleeve.

⚠ CAUTION: Lamp and quartz sleeve are easily damaged. Exercise care when handling.

5. Reinstall lamp in reverse order.

⚠ WARNING: Germicidal ultraviolet rays are harmful to eyes and skin. Do not restore power to water purifier until lamp and easy-off end caps have been properly reinstalled.

QUARTZ SLEEVE CLEANING OR REPLACEMENT

Figure 9 - Quartz Sleeve Cleaning or Replacement
MIN-6 120v 50/60Hz (ballast no. 10-0015B)

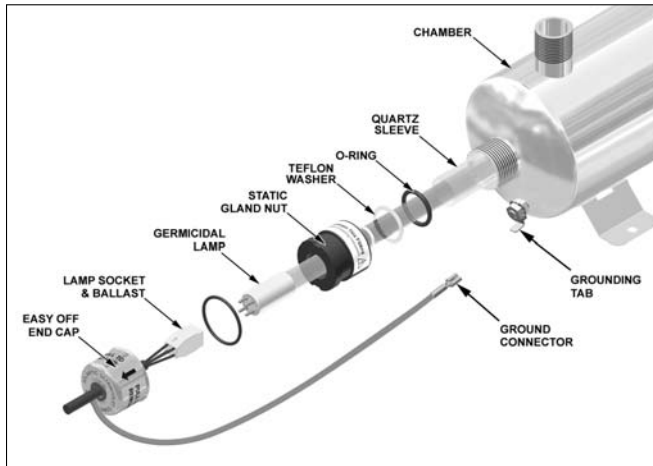
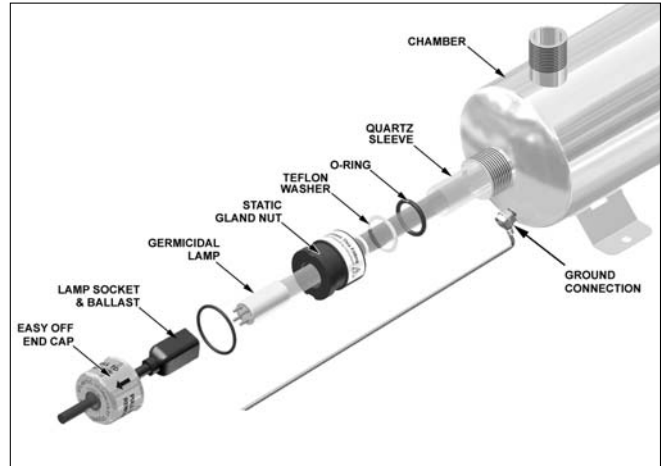

Figure 10 - Quartz Sleeve Cleaning or Replacement
MIN-6 230v 50/60Hz (ballast no. 10-0504A)



Step 4 - Remove Gland Nuts



Step 5 - Remove Washers & O-Rings

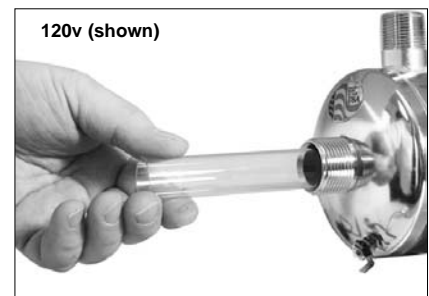

Step 6 - Remove Quartz Sleeve

1. **Disconnect power to water purifier.**

- For **120v** 50/60Hz version using ballast no. 10-0015B, remove the ground connector from the chamber, and go to the next step.
- For **230v** 50/60Hz version using ballast no. 10-0504A, go to next step.

2. Shut off water supply to water purifier via inlet and outlet shut off valves and drain chamber, if possible.

3. Follow the steps in “**LAMP INSTALLATION OR REPLACEMENT**” to remove lamp.

▲ CAUTION: Lamp and quartz sleeve are easily damaged. Exercise care when handling.

4. Unscrew static gland nuts from each end of the chamber. Avoid striking quartz sleeve with static gland nut.
5. Remove Teflon® washer and O-ring from both ends of quartz sleeve. Teflon® washer will sometimes remain within the static gland nut. If so, remove Teflon® washer from static gland nut before proceeding.
6. Carefully remove quartz sleeve from chamber. **NOTE:** It is advisable to support the quartz sleeve on the backside with your finger so that it does not drop to the bottom of the chamber as it slides into the chamber.
7. Once the quartz sleeve is removed, clean with alcohol or a detergent. Stubborn stains usually can be removed with a dilute hydrochloric acid. **NOTE:** Follow all manufacturer's instructions and precautions when handling chemicals.
8. Reassemble in reverse order. Make sure the quartz sleeve protrudes an equal distance past each threaded nipple. Be sure O-rings are placed on quartz sleeve before Teflon® washer.
9. Tighten static gland nuts firmly by hand only, **DO NOT USE HAND TOOLS**. Tightening with hand tools is likely to cause quartz sleeve to break.
10. When all connections are complete allow water to enter the water purifier at a low flow rate until the purifier is pressurized. With the purifier pressurized, it should be checked for leaks.
11. If no leaks occur, reinstall lamp, following the steps in “**LAMP INSTALLATION OR REPLACEMENT**” section.

▲ WARNING: Germicidal ultraviolet rays are harmful to eyes and skin. Do not restore power to water purifier until lamp and both easy-off end caps have been properly reinstalled.

REPLACEMENT OF BROKEN QUARTZ SLEEVE

▲ CAUTION: Broken Quartz is SHARP. It is recommended that protective goggles and gloves are worn when handling.

1. **Disconnect power to water purifier.**
 - For **120v** 50/60Hz version using ballast no. 10-0015B, remove the ground connector from the chamber, and go to the next step.
 - For **230v** 50/60Hz version using ballast no. 10-0504A, go to next step.
2. Shut off water supply to water purifier via inlet and outlet shut off valves and drain chamber, if possible.
3. Follow the steps in “**LAMP INSTALLATION OR REPLACEMENT**” to remove lamp.
4. Unscrew static gland nuts from each end of the chamber. Avoid striking quartz sleeve with static gland nut.
5. Remove Teflon[®] washer and O-ring from both ends of quartz sleeve. Teflon[®] washer will some times remain within the static gland nut. If so, remove Teflon[®] washer from static gland nut before proceeding.
6. Carefully remove as much of the broken quartz sleeve as possible, from each end of the chamber.
7. To remove fragments of quartz sleeve, hold the purifier vertically and shake. The quartz fragments will break and drop out of the purifier through the gland fitting. Flush water through chamber being careful to remove all quartz fragments from the interior of the chamber.
8. **Carefully** discard all pieces of the broken quartz sleeve.
9. Align the end of the quartz sleeve with the gland fitting of the chamber.
10. Carefully slide the quartz sleeve into the chamber, guiding it through the gland fitting. **NOTE:** Use care to keep the quartz sleeve parallel to the chamber, angling the quartz sleeve in any direction could result in the breakage of the quartz sleeve.
11. As the quartz sleeve nears the far end of the chamber, support the quartz sleeve by inserting your finger through the far end gland fitting and into the quartz sleeve. This will minimize the possibility of breaking the quartz sleeve as it passes through the gland fitting.
12. Center the quartz sleeve in the chamber, making sure the quartz sleeve protrudes an equal distance past each threaded gland fitting, of the chamber.
13. Re-install O-rings, Teflon[®] washers, and static gland nuts. Be sure O-rings are placed on quartz sleeve before Teflon[®] washer. Tighten static gland nuts firmly by hand only, **DO NOT USE HAND TOOLS**. Tightening with hand tools is likely to cause quartz sleeve to break.
14. When all connections are complete allow water to enter the water purifier at a low flow rate until the purifier is pressurized. With the purifier pressurized, it should be checked for leaks.
15. If no leaks occur, reinstall lamp, following the steps in “**LAMP INSTALLATION OR REPLACEMENT**” section.

DISPOSAL OF MERCURY ADDED LAMPS

Germicidal ultraviolet lamps, like standard fluorescent lamps contain small amounts of mercury. Mercury added lamps should not be placed in the trash. Dispose of properly.

For further information regarding the disposal and recycling of lamps containing mercury, along with Federal and State requirements visit <http://www.lamprecycle.org>. Product Data Sheets for germicidal ultraviolet lamps can be found in the “PDF Library for **STER-L-RAY**[®] Germicidal Ultraviolet Lamps” section of <http://www.ultraviolet.com>.

TROUBLESHOOTING

▲ WARNING: Always disconnect power to the water purifier before performing any service or maintenance.
IMPORTANT: This unit is to be serviced **ONLY** by qualified, and appropriately licensed, personnel.

Table 3 - Troubleshooting

Problem	Possible Cause	Corrective Action
Purifier not operating.	No electrical power...	Verify that the purifier is connected to a live power source.
Water leaking into/from purifier.	Cracked or broken quartz sleeve...	Shut down purifier, drain, and replace quartz sleeve. See “ Quartz Sleeve Cleaning or Replacement ” in the “ Maintenance ” section.
	Quartz sleeve sealing O-ring (s) worn, damaged...	Shut down purifier, drain, and remove static gland nut, replace sealing O-ring. See “ Quartz Sleeve Cleaning or Replacement ” in the “ Maintenance ” section.
	Poor, or loose, connections or fittings...	Tighten suspect connection or fitting; or shut down purifier, drain, and remove fitting or connection. Clean threads; reapply thread sealing tape and reinstall.
Poor purifier performance	Quartz sleeve fouled...	Clean quartz sleeve, see “ Quartz Sleeve Cleaning or Replacement ” in the “ Maintenance ” section.
	Germicidal lamp output depreciating...	Replace lamp, as it nears its end of life (EOL). See “ Lamp Replacement ” in the “ Maintenance ” section.
	Germicidal lamp not functioning...	Replace lamp. See “ Lamp Replacement ” in the “ Maintenance ” section.
	Low input voltage...	Verify input voltage to purifier.
	Change in water quality...	Have water tested to confirm that it does not exceed maximum recommended concentration levels for use with this purifier.

TECHNICAL SPECIFICATIONS

Table 4 - Technical Specifications

MODEL:	MIN-6
Flow Rate (GPM):	6
Inlet\Outlet Size:	$\frac{3}{4}$ "MNPT
Number of Lamps:	1
Lamp Model No.:	05-1370-R
Length:	22 $\frac{17}{32}$ "
Width:	4 $\frac{1}{4}$ "
Height:	5 $\frac{3}{8}$ "
Chamber Diameter:	4 $\frac{1}{4}$ "
Shipping Weight:	14 Lbs
Voltage:①	120V 50/60Hz
Power Consumption:②	21 Watts
Max Operating Pressure:	100 PSI
Ambient Temperature:	33° F - 100° F
Quartz Sleeve:	1
Sentry™ Safety Sensor	Optional
Audio Alarm:	Optional
Time Delay Mechanism:	Optional
Elapsed Time Indicator, Universal Input	Optional
Solenoid Valve:	Optional
Flow Control:	Optional

① 230V 50/60Hz, 12V, or 24V DC units are also available.
Consult Factory for specific voltage requirements.

② Total power consumption, including ballast loss.

All specifications, dimensional data, etc are approximate and subject to change without notice.

REPLACEMENT PARTS

Figure 11 - Exploded View MIN-6 120v 50/60Hz using ballast no. 10-0015B (shown)

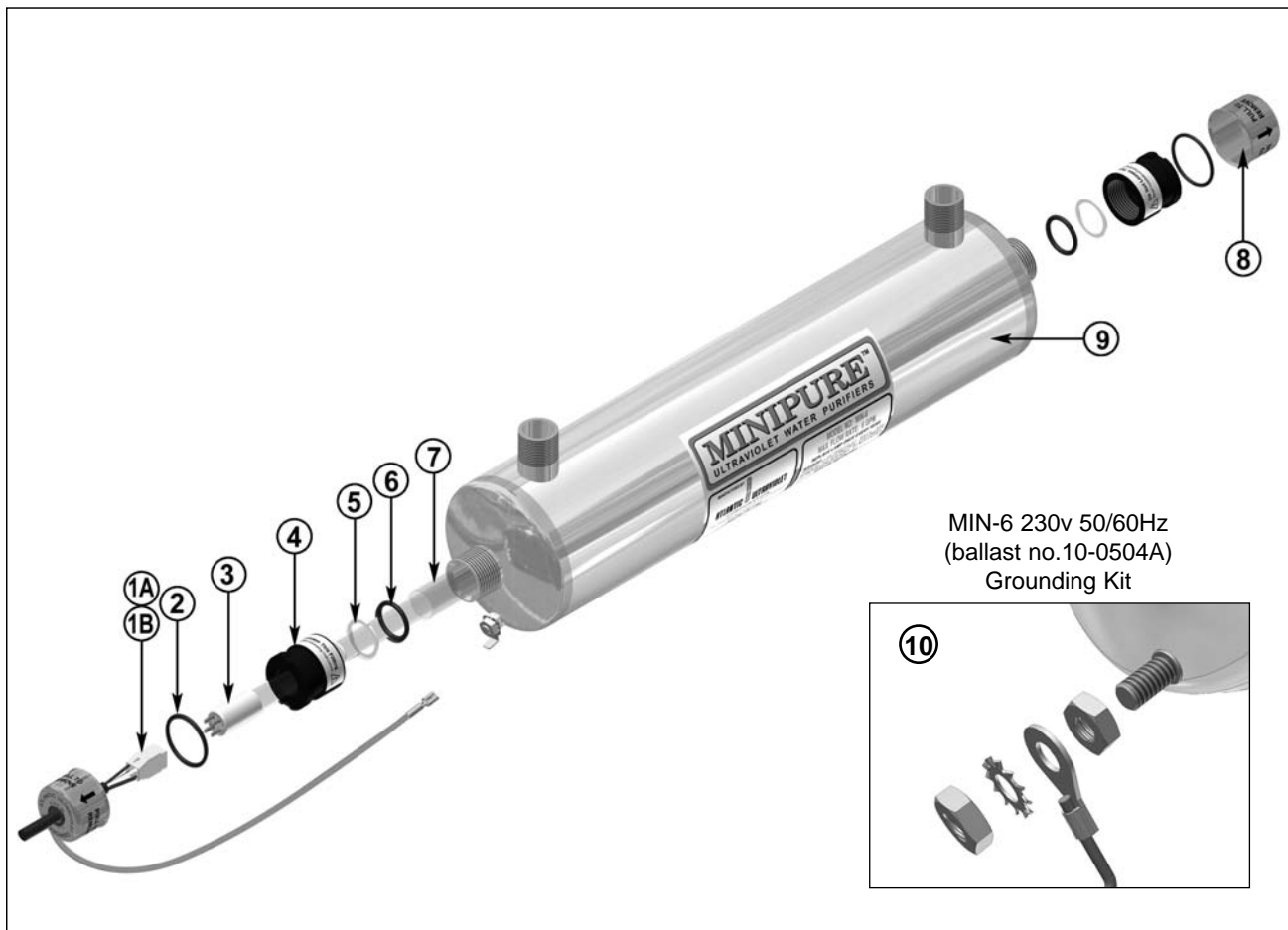

MIN-6 230v 50/60Hz
(ballast no.10-0504A)
Grounding Kit

Table 5 - Replacement Parts

MIN-6 120v 50/60Hz (ballast no.10-0015B) & MIN-6 230v 50/60Hz (ballast no.10-0504A)

ITEM NO.	DESCRIPTION	QUANTITY	PART NO.
1A	Lamp Socket & Ballast, 120v 50/60Hz	1	10-0015B
1B	Lamp Socket & Ballast, 230v 50/60Hz	1	10-0504A
2	Rubber O-ring, Static Gland	2	00-1108B
3	Lamp	1	05-1370-R
4	Static Gland Nut	2	25-1492D
5	Teflon [®] Washer	2	25-1235A
6	Rubber O-ring, Quartz Sleeve	2	00-1238A
7	Quartz Sleeve	1	15-1112A
8	Easy-Off End Cap (no hole)	1	25-1493A
9	Chamber	1	25-0448
10	Grounding Kit	1	35-8300A

All specifications, dimensional data, etc are approximate and subject to change without notice.

USER ASSISTANCE

Atlantic Ultraviolet Corporation makes every effort to ensure that the **MINIPURE**® Ultraviolet Water Purifiers are products of superior quality and workmanship. This manual describes the installation, operation and maintenance of the **MINIPURE**® Ultraviolet Water Purifiers.

Please read and become familiar with the contents of this manual before installing or using this unit. If after reading the manual you still have questions, or concerns, regarding the installation or use of this unit, contact our offices, weekdays between 8:30 am and 5:00 pm Eastern time, at:

Atlantic Ultraviolet Corporation
375 Marcus Boulevard
Hauppauge, New York, 11788

Tel: 631.273.0500
Fax: 631.273.0771

E-mail: info@ultraviolet.com
Website: www.ultraviolet.com

Please REGISTER your product immediately - you can do this in a number of ways. Go online to Ultraviolet.com and on the bottom left of each page either click on "Fill out Warranty Reg. Form on-line!" complete and hit submit or click on "Download a PDF of the Warranty Reg. card" which you can print, fill out and mail in. If you prefer to register over the telephone please call 631-273-0500.

Atlantic Ultraviolet Corporation takes all possible precautions when packaging equipment to prevent damage. Carefully inspect and report all damage. **Do not** install damaged equipment. Follow all instructions on any labels or tags. Carefully inspect all packing materials before discarding to prevent the loss of accessories, mounting hardware, spare parts or instructions.

For your convenience, record the following information below. The model and serial number can be found on a label located on the **MINIPURE**® Ultraviolet Water Purifiers. Keep this manual, along with proof of purchase, handy when contacting our offices.

Purchased From:	Date:
Model:	Serial No.:

WARRANTY

We warrant that this product will be free from defects in material and workmanship for a period of one year from the date of shipment thereof or the product's total rated life, whichever first occurs. Within the warranty period we shall repair or replace such products, which are returned to us with shipping charges prepaid, and which are determined by us to be defective. This warranty will not apply to any product, which has been subjected to misuse, negligence, or accident; or misapplied; or modified; or repaired by unauthorized persons; or improperly installed.

The buyer shall inspect the product promptly after receipt and shall notify us at our main office in writing of claims, including claims of breach of warranty, within thirty (30) days after the buyer discovers or should have discovered the facts upon which the claim is based. Failure of the buyer to give written notice of a claim within the time period shall be deemed to be a waiver of such claim.

The provisions of the above warranty are our sole obligation and exclude all other remedies or warranties, expressed or implied, including warranties of merchantability and fitness for a particular purpose, whether or not purposes or specifications are described herein. We further disclaim any responsibility whatsoever to the customer, or to any person, for injury to person, damage to, or loss of property or value caused by any product which has been subjected to misuse, negligence, accident; or modified or repaired by unauthorized persons; or improperly installed.

Under no circumstances shall the Atlantic Ultraviolet Corporation be liable for any incidental, consequential or special damages, losses or expenses arising from the contract for this product, or in connection with the use of, or inability to use, our product for any purpose whatsoever.

PATENT NOTICE

No attempt has been made to determine the patent status of applications illustrated or described in this publication. Inclusion in this publication of any design or method of use, which may be patented, is not to be construed as promoting or sanctioning unauthorized use.