

Please carefully read and save these instructions before attempting to assemble, maintain, install, or operate this product. Observe all safety information to protect yourself and others. Failure to observe the instructions may result in property damage and/or personal injury. Please keep instructions for future reference.

Important Operating Instructions



9 GALLON 6.5HP TWIN TANK GAS AIR COMPRESSOR

Model: 9528

CALIFORNIA PROPOSITION 65

WARNING: You can create dust when you cut, sand, drill or grind materials such as wood, paint, metal, concrete, cement, or other masonry. This dust often contains chemicals known to cause cancer, birth defects, or other reproductive harm. Wear protective gear.

WARNING: This product or its power cord may contain chemicals, including lead, known to the State of California to cause cancer and birth defects or other reproductive harm. Wash hands after handling.

Important!

When using equipment, a few safety precautions must be observed to avoid injuries and damage. Please read the complete operating manual with due care. Keep this manual in a safe place, so that the information is available at all times. If you give the equipment to any other person, give them these operating instructions as well. We accept no liability for damage or

accidents which arise due to non-observance of these instructions and the safety information herein.

SPECIFICATIONS

Engine: 6.5 HP OHV
Tank capacity: 9 gallons
Pressure: 115 PSI
Speed: 1150 RPMs
12 CFM @ 90 PSI

CAUTION:
**FOR YOUR OWN SAFETY,
READ INSTRUCTION MANUAL
COMPLETELY AND
CAREFULLY BEFORE
OPERATING THIS GAS
COMPRESSOR.**

**Any failures made in
following the safety
regulations and instructions
may result in an electric
shock, fire and/or serious
injury.**

SAFETY INSTRUCTIONS

- 1) Only persons who are familiar with these instructions and warnings should operate this compressor.
- 2) Do not allow children in the work area and keep visitors back away from equipment.
- 3) Use safety glasses and hearing protection when you are operating this unit.
- 4) Do not stand on the unit or use it as a handhold.
- 5) Before each use, inspect the compressor for signs of damage, deterioration, weakness or leakage. Repair or replace damaged items before use.
- 6) Check the fasteners at frequent intervals to ensure proper tightness.
- 7) Motors, electrical equipment and their

For warranty purchases, please keep your dated proof of purchase. File or attach to the manual for safekeeping.

controls can cause electrical arcs that could ignite flammable gas or vapors. Do not store any flammable liquids or gases near the compressor.

8) Carbon monoxide is produced when operating this unit and can cause severe nausea, fainting or death. Do not operate this unit in a poorly ventilated area or while inside a closed building.

9) Never operate a compressor without a belt guard. It is possible for a compressor to start without warning. Personal injury or property damage could occur from coming in contact with moving parts.

10) Do not wear loose clothing or jewelry. Keep long hair pulled back.

11) Compressor parts may be hot even though the unit may be stopped.

12) Keep fingers and appendages away from the compressor while it is running. Fast moving and hot parts can cause injury and/or burns.

13) If any of the equipment starts to vibrate abnormally, stop the engine/motor and inspect the unit immediately for the cause.

14) Never refuel a running or hot engine. Fuel is explosive and can cause fires and severe burns. Avoid overfilling the fuel tank.

15) Check the fuel level before starting the engine. Do not fill the gas tank while indoors. Wipe off any spilled gas from the unit before starting the engine.

16) Gasoline vapors are highly flammable. Only refill the tank outdoors or in a well-ventilated area. Do not store, use or allow spills near an open flame or heat devices that utilize a pilot light or could create a spark. If gasoline is spilled, move the unit away from the spill and avoid creating any sparks until the vapors have evaporated.

17) In order to reduce the fire hazard, keep the engine and motor exterior free of oil, solvents or excessive grease.

18) Never remove or attempt to adjust the safety valve. Keep the safety valve free from paint and other accumulations.

19) Never attempt to repair or modify a tank. Welding, drilling or any other modifications made will weaken the tank and result in damage by rupture or explosion. Always replace worn or damaged tanks.

20) Make sure to drain the tank regularly and inspect it periodically for unsafe conditions such as rust and corrosion.

21) Release air slowly when draining moisture or depressurizing the air compressor system. Fast moving air will stir up dust and debris, which may be harmful.

22) Stop the engine and make sure all moving parts have stopped when leaving the work area, before cleaning, making repairs or inspecting the unit.

23) Allow the engine to cool before storing the unit.

24) Do not spray flammable materials within the vicinity of an open flame or near ignition sources, including the compressor unit.

25) Do not smoke when spraying paint, insecticides or other flammable substances.

26) Use a facemask when spraying. Spray in a well ventilated area to prevent health and fire hazards.

27) Do not direct any sprayed materials at the compressor. Keep the compressor as far away as possible from the spraying area to minimize the accumulation on the compressor.

OPERATION

Start Up

1) Add 87 octane (or higher) unleaded gasoline to the engine gas tank and SAE 10W-30 oil to the engine oil tank. A different viscosity oil may be required if the compressor is operated at different ambient temperatures. Please refer to the engine manual for more details.

2) Remove the compressor dipstick breather and fill the pump to the proper oil level. Use a single viscosity, ISO 100 (SAE 30) non-detergent compressor oil. Do not use a multi viscosity oil such as 10W-30.

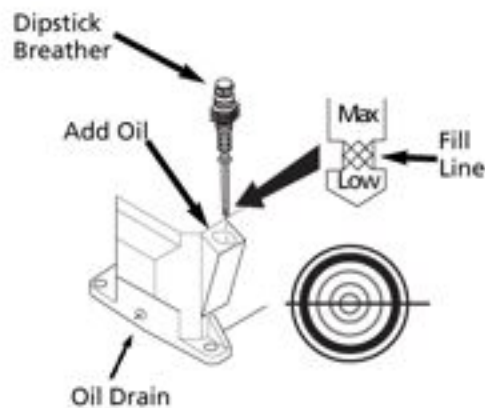

3) Turn the outlet valve or regulator knob counterclockwise to open the airflow.

4) Turn the manual unloader lever to a vertical position in order to allow the compressor pump to run without compressing air.



Unloaded Position

Starting A Gasoline Engine

1) Move the choke lever to the CHOKE position and turn the stop lever towards the ON position.

2) Pull the start grip lightly until resistance is felt, then pull on the start grip briskly to start the engine.

3) As the engine begins to warm up, gradually move the choke lever to the OPEN position.

4) Run the compressor at an unloaded speed for approximately 30 minutes in order to break in the pump.

5) After approximately 30 minutes of run time, move the unloader lever down to the loaded position and turn the regulator knob clockwise. The compressor will begin to pump air into the tank at this time.

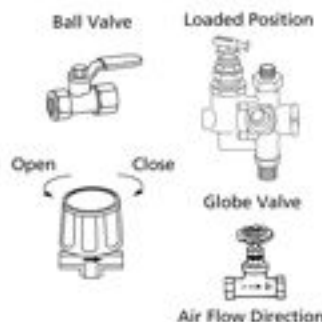

When the maximum tank pressure is achieved, the compressor automatically unloads, which brings the engine to idle. The engine remains at the idle state until the pressure in the tank falls to a preset level. The engine will then accelerate and the compressor will pump additional air into the tank.

MAINTENANCE

WARNING: Release all pressure from the system before attempting to perform any maintenance, relocate, service or install the unit.

Check the air filter, oil level and gasoline level before each use in order to maintain efficient operation of the unit.

The ASME safety valve should be checked before each use. Pull the ring on the safety valve and allow the ring to snap back into its normal position. This valve automatically releases air if the tank pressure exceeds a preset maximum. If air leaks after the ring has been released, or if the valve is stuck and cannot be actuated by the ring, the ASME safety valve must be replaced. **Do not attempt to tamper with the ASME safety valve.**

With the engine OFF, clean any debris from the engine, flywheel, tank, air lines and pump cooling fins.

Never attempt to repair or

modify the tank. Welding, drilling or any other modifications will weaken the tank and could result in damage from rupture or explosion. Always replace worn, cracked or damaged tanks as soon as possible.

Drain liquid from the tank at the end of each use.

Drive Belt

Belts will stretch as a result of normal use. When they are properly adjusted, the belt deflects about 1/2 inch with 5 pounds of pressure applied midway between the engine pulley and pump.

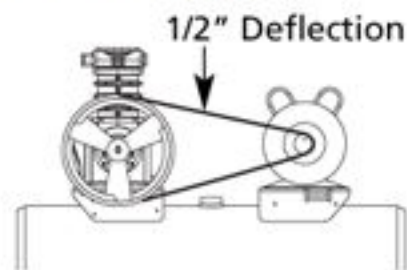

To adjust the drive belt tension:

- 1) Remove the belt guard and loosen the engine brace.
- 2) Loosen the four fasteners that are holding the motor to the base plate.
- 3) Shift the motor in the proper direction. The belt must be properly aligned when this adjustment is made.
- 4) To align the belt, lay a straight edge against the face of the flywheel, touching the rim at two places.

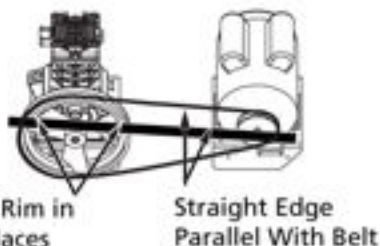

5) Adjust the flywheel or motor pulley so that the belt runs parallel to the straight edge.

6) Use a gear puller to move the pulley on the shaft and to tighten the fasteners.

7) Adjust the brace and then tighten the fasteners, braces and reinstall the belt guard.

Storage

1) When the unit is not in use, the air hose and compressor should be stored in a cool, dry location.

2) Tanks should be drained of moisture. The hose should be disconnected and hung with the open ends down to allow any moisture to drain.

Maintenance Schedule

Check Oil: Daily

Drain Tank: Daily

Check Air Filter: Weekly

Check Safety Valve: Weekly

Blow Dirt From Inside Motor: Weekly

Check Belt Tightness: Monthly

Change Oil: Every 3 Months

Troubleshooting Guide

Problem	Possible Cause	Possible Solution
Engine does not start	Low oil shutdown	Fill engine with adequate amount of oil
	Cold engine	Choke engine to start
	No fuel	Add gas to engine. Make sure fuel shutoff valve is open.
	Engine does not turn ON	Place ON/OFF switch in the ON position
	Spark plug wire not attached	Attach spark plug wire to spark plug
Air delivery drops off	Air leaks in discharge piping	Check tubing connections. Tighten joints or replace as required.
	Compressor components are leaky, broken or loose	Inspect the components and clear or replace as required
	Flywheel or motor pulley is loose, excessive end play in motor shaft or loose drive belts	Check flywheel, motor pulley or the crankshaft drive belt tension/alignment. Replace or repair as required
	Clogged or dirty inlet and/or discharge line	Clean or replace
	Defective safety/relief valve	Replace
	Pressure switch unloader leaks or does not work	Realign stem or replace
	Leaking, broken or worn inlet unloader parts at check valve	Inspect parts and replace as required
Compressor does not come up to speed	Compressor viscosity is too high for the ambient temperature	Drain the existing lubricant and refill the tank with the proper lubricant
	Belt tension is too tight or sheaves are not aligned	Check the tension and/or alignment
	Flywheel or motor pulley is loose, excessive end play in motor shaft or loose drive belts	Check flywheel, motor pulley or the crankshaft drive belt tension/alignment. Replace or repair as required
	Leaking check valve or check valve seat is blown out	Replace check valve
High interstage pressure	High pressure inlet valve leaking	Inspect, clean or repair as required
Low interstage pressure	Low pressure inlet valve leaking	Inspect, clean or repair as required

Problem	Possible Cause	Possible Solution
Compressor is slow to come up to speed	Compressor viscosity is too high for the ambient temperature	Drain the existing lubricant and refill the tank with the proper lubricant
	Belt tension is too tight or sheaves are not aligned	Check the tension and/or alignment
	Flywheel or motor pulley is loose, excessive end play in motor shaft or loose drive belts	Check flywheel, motor pulley or the crankshaft drive belt tension/alignment. Replace or repair as required
	Leaking check valve or check valve seat is blown out	Replace check valve
	Clogged or dirty inlet and/or discharge line	Clean or replace
Compressor will not unload cycle or will not unload when stopped	Air leaks in discharge piping	Check tubing connections. Tighten joints or replace as required.
	Clogged or dirty inlet and/or discharge line	Clean or replace
	Pressure switch unloader leaks or does not work	Realign stem or replace
	Leaking, broken or worn inlet unloader parts at check valve	Inspect parts and replace as required
Excessive starting or stopping	Pressure switch unloader leaks or does not work	Realign stem or replace
	Excessive condensation in receiver tank	Drain receiver tank
	Light duty cycle	Increase duty cycle
Moisture in crankcase, milky substance in oil	Detergent lubricant in crankcase	Replace with proper lubricant
	Oil in discharge air	Lubricant level too high
Safety/relief valve pops	Clogged or dirty inlet and/or discharge line	Clean or replace
	Defective safety/relief valve	Replace
	Pressure switch unloader leaks or does not work	Realign stem or replace

Limited Manufacturer Warranty

North American Tool (NAT) Industries makes every effort to ensure that this product meets high quality and durability standards. NAT warrants to the original retail consumer a 1-year limited warranty from the date the product was purchased at retail and each product is free from defects in materials. Warranty does not apply to defects due directly or indirectly to misuse, abuse, negligence, or accidents, repairs or alterations, or a lack of maintenance. NAT shall in no event be liable for death, injuries to persons or property, or for incidental, special, or consequential damages arising from the use of our products. To receive service under warranty, the original manufacturer part must be returned for examination by an authorized service center. Shipping and handling charges may apply. If a defect is found, NAT will either repair or replace the product at its discretion.

DO NOT RETURN TO STORE

For Customer Service:

Email: feedback@natitools.com or Call 1-800-348-5004



9 GALLON 6.5HP TWIN TANK GAS AIR COMPRESSOR

Model: 9528

Parts List

Exploded View

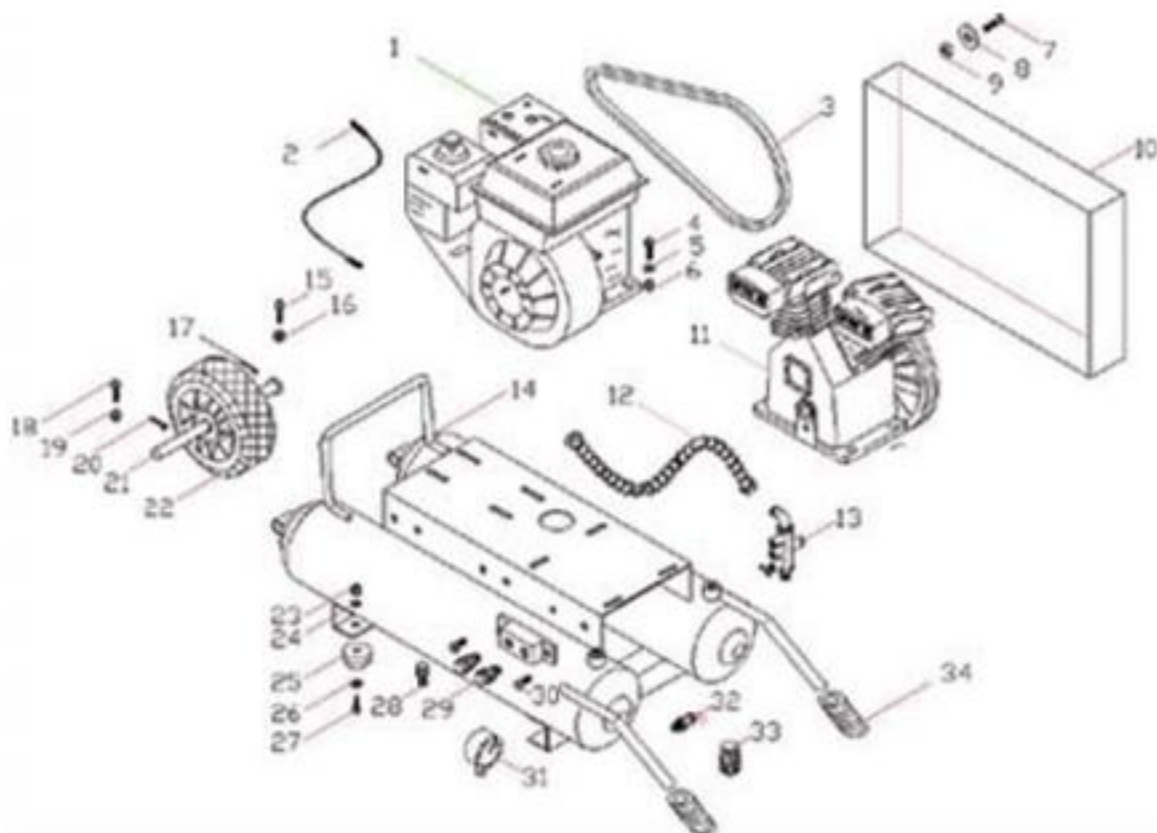

No.	Description	Quantity
1	Engine	1
2	Cable	1
3	Bolt	1
4	Bolt	4
5	Spring Washer	4
6	Nut	4
7	Bolt	4
8	Washer	4
9	Nut	4
10	Belt Guard	1
11	Pump	1
12	Copper Tube	1

No.	Description	Quantity
13	Comb Valve	1
14	Tank	1
15	Bolt	1
16	Spring Washer	4
17	Cotter Pin	4
18	Bolt	4
19	Spring Washer	4
20	Cotter Pin	4
21	Axle	4
22	Tire	1
23	Nut	4
24	Spring Washer	4

No.	Description	Quantity
25	Bumper	4
26	Washer	4
27	Bolt	4
28	Drain Valve	2
29	Quick Connect	2
30	Bolt	2
31	Pressure Gauge	1
32	Safety Valve	1
33	Regulator	1
34	Grip	1



9 GALLON 6.5HP TWIN TANK GAS AIR COMPRESSOR

Model: 9528

Parts List

Pump Assembly

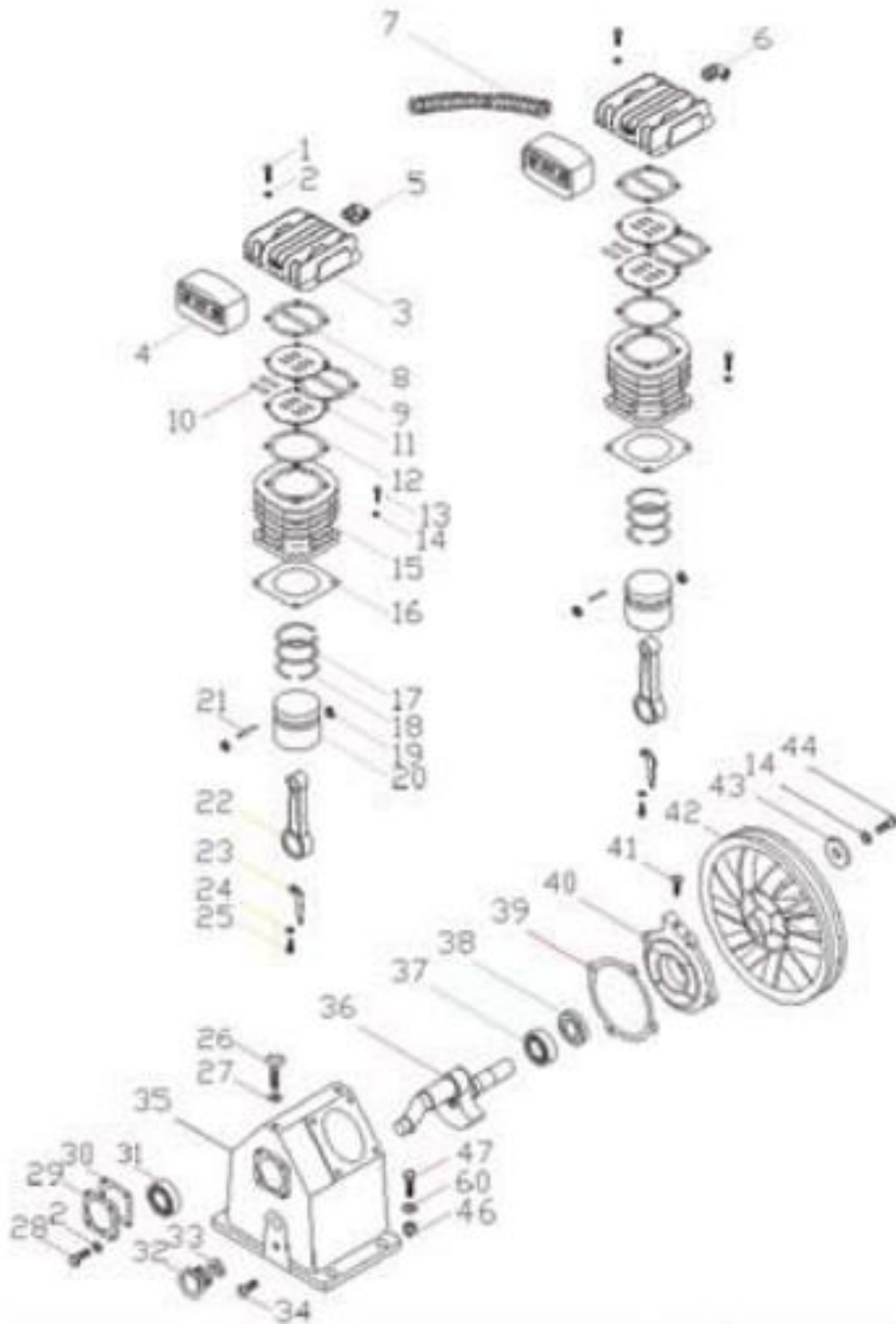

Call 1-800-348-5004 for assistance or replacement parts

Please provide the following information:

- Model number
- Part description and number as shown in parts list
- Serial number (if any)

Address any correspondence to:

North American Tool Industries
84 Commercial Rd
Huntington, IN 46750

No.	Description
1	Bolt
2	Split Washer
3	Head
4	Filter
5	Exhaust Elbow
6	Elbow
7	Aluminum Pipe
8	Head Washer
9	Aluminum Washer
10	Valve Seat
11	Valve Plate
12	Cylinder Up Washer
13	Bolt
14	Split Washer
15	Cylinder
16	Cylinder Down Washer
17	Compressor Ring
18	Oil Ring
19	Retaining Ring in Hole
20	Piston
21	Piston Pin
22	Connector Rod
23	Oil Needle
24	Bolt

No.	Description
25	Split Washer
26	Bolt
27	Split Washer
28	Bolt
29	Crankcase Cover
30	Crankcase Washer
31	Bearing
32	Oil Window
33	O-Ring
34	Oil Drain Plug
35	Crankcase
36	Crank Shaft
37	Bearing
38	O-Ring
39	Crankcase Back Washer
40	Crankcase Back Cover
41	Bolt
42	Pulley
43	Split Washer
44	Bolt
45	Split Washer
46	M8 Nut
47	Bolt