

FOR AGES:

13+

WEIGHT LIMIT:

220 Lbs
100 Kgs

ADULT(S) NEEDED:



TOOLS NEEDED:



WARNING/ADVERTENCIA

- Do not allow more than one person on this product at any time.
- Children must be supervised by an adult at all times.
- Not recommended for children under 13 years of age.
- The contents of this package are not suitable for children under 3 years of age. Contains small parts which may cause choking.
- ADULT ASSEMBLY REQUIRED.

CUSTOMER SERVICE

-  GQBrands.com
-  CustomerService@GQBrands.com
-  1-866-498-5269
-  4009 Distribution Dr, Suite 240
Garland, TX 75041

CUSTOMER SERVICE INFORMATION

Thank you for purchasing:

40" MINI TRAMPOLINE WITH HANDRAIL

MODEL# 9040MTH

At Global Quality Brands®, we want all of our customers to be completely satisfied with their purchase. Please take time to review the contents of the product you have just received to make sure that all of the parts are included. If you find that any parts are missing or damaged, we will happily provide replacement parts at no charge within 30 days of purchase.

Please keep in mind that for select damaged part replacement requests, we will require a photo for submission.

If you request replacement parts, please be sure to include the following information in your correspondence:

To order these parts, or if you have any other questions or concerns about this GQ Brands product, please contact us at:

www.JamzFitness.com
Phone: 1-866-498-5269
Email: customerservice@gqbrands.com
4009 Distribution Dr, Suite 240
Garland, TX 75041

Sincerely,
Customer Service

YOUR NAME:

YOUR MAILING ADDRESS:

YOUR EMAIL ADDRESS:

PRODUCT NAME:

PRODUCT MODEL #:

PART # (Located In Manual)

RETAILER WHERE YOU PURCHASED PRODUCT:

DATE OF PURCHASE:

ORDER # (If Available)

SERIAL#:

QUANTITY NEEDED:

PICTURE OF DAMAGED PART(s) SUBMIT VIA Email, Fax, or Mail

LIMITED WARRANTY

Global Quality Brands® warrants this product to be free from defects in workmanship and materials under normal use and conditions for a period of 90 DAYS FROM THE DATE OF ORIGINAL PURCHASE. This Limited Warranty is not transferable and is available only for the original purchaser of the Product. The Company's obligation under this warranty is limited to replacing or repairing the Product, at the discretion of the company.

All warranty coverage extends only to the original retail purchaser from the date of purchase, GQ Brands obligation under this warranty is limited to replacing or repairing, at Global Quality Brands® option. All products for which a warranty claim is made must be received by Global Quality Brands® and accompanied by sufficient proof of purchase (photocopy of the original store receipt, indicating the date of purchase). All freight and handling fees are the responsibility of the consumer to pay, both to and from Global Quality Brands®. All warranty claims must be preauthorized by Global Quality Brands® pre-authorization can be obtained by calling 866-498-5269.

This warranty does not cover ordinary wear and tear, weathering, failure to follow directions, improper installation, improper maintenance, or acts of nature, (such as damage caused by wind, lightning, snow, water, or ice) weather damage, damage caused by unauthorized repair work or damage caused by improper use of the products are not covered by the product warranty. No other warranty beyond that specifically set forth above is authorized by GQBrands®.

GLOBAL QUALITY BRANDS® IS NOT RESPONSIBLE OR LIABLE FOR INDIRECT, SPECIAL OR CONSEQUENTIAL DAMAGES ARISING OUT OF OR IN CONNECTION WITH THE USE OR PERFORMANCE OF THE PRODUCT OR OTHER DAMAGES WITH RESPECT TO ANY ECONOMIC LOSS, LOSS OF PROPERTY, LOSS OF REVENUE OR PROFITS, LOSS OF ENJOYMENT OR USE, COST OF REMOVAL, INSTALLATION OR OTHER CONSEQUENTIAL DAMAGES. SOME STATES DO NOT ALLOW THE EXCLUSION OR LIMITATION OF INCIDENTAL OR CONSEQUENTIAL DAMAGES. ACCORDINGLY, THE ABOVE LIMITATION MAY NOT APPLY TO YOU. THE WARRANTY EXTENDED HEREUNDER IS IN LIEU OF ALL OTHER WARRANTIES AND GLOBAL QUALITY BRANDS®, SPECIFICALLY DISCLAIMS ANY IMPLIED WARRANTY OF MERCHANTABILITY OR FITNESS FOR A PARTICULAR PURPOSE IS LIMITED IN ITS SCOPE AND DURATION TO THE TERMS SET FORTH HEREIN. SOME STATES DO NOT ALLOW LIMITATION ON HOW LONG AN IMPLIED WARRANTY LASTS. ACCORDINGLY, THE ABOVE LIMITATION MAY NO APPLY TO YOU. THIS WARRANTY GIVES YOU SPECIFIC LEGAL RIGHTS. YOU MAY ALSO HAVE OTHER RIGHTS, WHICH VARY FROM STATE TO STATE.

WHILE EVERY ATTEMPT IS MADE TO ENSURE THE HIGHEST DEGREE OF PROTECTION IN ALL EQUIPMENT, WE CANNOT GUARANTEE FREEDOM OF INJURY. THE USER ASSUMES ALL RISK OF INJURY DUE TO USE. ALL MERCHANDISE IS SOLD ON THIS CONDITION, WHICH NO REPRESENTATIVE OF GQ BRANDS® CAN WAIVE OR CHANGE.



IMPORTANT MESSAGE

WARNING - PLEASE READ

ADULT ASSEMBLY REQUIRED

CHOKING HAZARD - Small Parts

NOT for children under 3 years of age.

WARNING:

While every attempt is made to ensure the highest degree of protection in all equipment, we cannot guarantee freedom from injury. The user assumes all risks of injury due to use. All merchandise is sold on this condition, which no representative of the company can waive or change.

WARNINGS

Please read these warnings and the information in this manual in its entirety.

Failure to comply with the following instructions may increase the risk of serious injury and/or death:

- This unit is designed only for jogging in place and similar bounding exercises.
- Not recommended for children under 13 years of age.
- Maximum weight limit: 220lbs. (100kgs)
- Children MUST NEVER use the trampoline unless supervised by a responsible adult with knowledge of trampoline use. DO NOT leave children unattended at any time.
- Caution and care must be taken in underneath a light or ceiling fan.
- The contents are not suitable for children under 3 years of age. This product contains small parts, which may cause choking.
- This trampoline is designed for one user only. Do not let more than one person use this product at the same time.
- Immediately discontinue use if any breakage to the frame assembly or springs are found. Failure to do this may result injury and/or further damage to the product.
- This trampoline is only designed for normal residential use. It is NOT intended for commercial applications and/or in public areas such as schools, parks, day cares, commercial/communal gyms, etc.
- When in use, your trampoline must be placed at a safe distance from any vertical or horizontal obstructions, such as stairways/stairwells, power lines, ceiling fans, pools, walls, overhead or wall light fixtures, windows, furniture, appliances, etc. Keep on a level surface.
- DO NOT store trampoline outdoors or where exposed to moisture or extreme temperatures.
- Ensure area under and around trampoline is clear of any toys/obstacles that may cause injury.
- DO NOT wear glasses or helmets when using the trampoline.
- DO NOT store items, playthings, or place any obstructions underneath the trampoline mat.
- Users should not wear clothing, jewelry, or anything could catch or snag on the product (e.g. loose clothing, cords, shoulder bags).
- DO NOT fall or bounce on your knees,.This can cause injury.
- DO NOT somersault. This can cause serious injury, paralysis, or death.
- DO NOT allow infants or animals to crawl underneath the trampoline mat.
- DO NOT use or allow use of the trampoline under the influence of any substance or medication which may impair the supervisor's or jumper's judgment and/or coordination.
- Users should stand or bounce as near to the center of the mat as possible. Bouncing or standing near the edge of the trampoline could cause the frame to tip over or damage the mat/springs.
- Do not allow small children to wander into the play area where the trampoline is in use.
- ALWAYS secure the trampoline against unauthorized and unsupervised use.
- ALWAYS wear socks when using the trampoline
- NEVER wear footwear (e.g. shoes) when using the trampoline.
- Before each use, inspect and replace any worn, defective or missing parts. It is important to check the trampoline to ensure the frame is steady and all parts are in good condition.
- Before each use, make sure the frame padding is in place with the springs and frame fully covered.
- ALWAYS make sure to store your trampoline safely, where it will not present a tripping or obstacle hazard.
- Dispose of all packaging materials safely and per local ordinance.

ASSEMBLY WARNINGS

- Make sure the trampoline is placed on a stable and leveled surface.
- Make sure the trampoline area is well lit.
- Make sure there are no obstructions above, beneath, or around the trampoline. In the interest of your safety, it is important that you read both the safety notice and the assembly instructions carefully before using or allowing use of this product.
- Ensure the feet are firmly secured and the frame pad covers the springs before each use.
- If you do not follow these guidelines, the user acknowledges responsibility for the increased risk of serious injury.
- The recommended overhead clearance is a minimum of 10 feet from any and all ceilings, overhead cables, ceiling fixtures or hard surfaces. In terms of horizontal clearance, ensure that potentially hazardous objects and conditions are located at a recommended minimum of 15 feet away from the trampoline (including but not limited to: electric cables, roadways, outdoor equipment, furniture, appliances, vehicles, lighting, walls, tree limbs, shelving, any overhangs, etc.) and no potentially hazardous conditions exist nearby (including but not limited to: stairwells, pools/hot tubs, any bodies of water, uneven or drop-off ground levels, etc.)

PARTS LIST

Part #	Description	QTY	Part#	Description	QTY
1	Frame	x1	8	50mm Square Neck Bolt	x4
2	Jumping Mat	x1	9	Nut	x16
3	Spring	x36	10	Washer	x8
4	W-Hook	x18	11	Frame Pad	x1
5	T-Section Piece	x8	12	Leg with Cap	x6
6	Cross-Section Piece	x4	13	Straight Pole	x2
7	40mm Square Neck Bolt	x12	14	Handle Bar with Foam Grip	x1

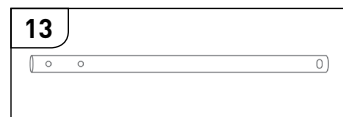
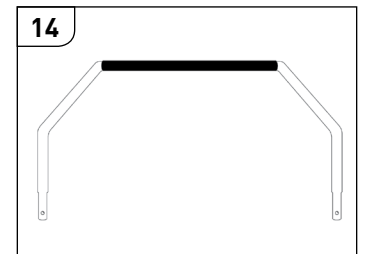
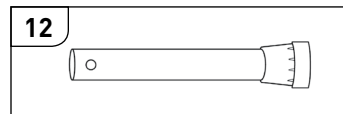
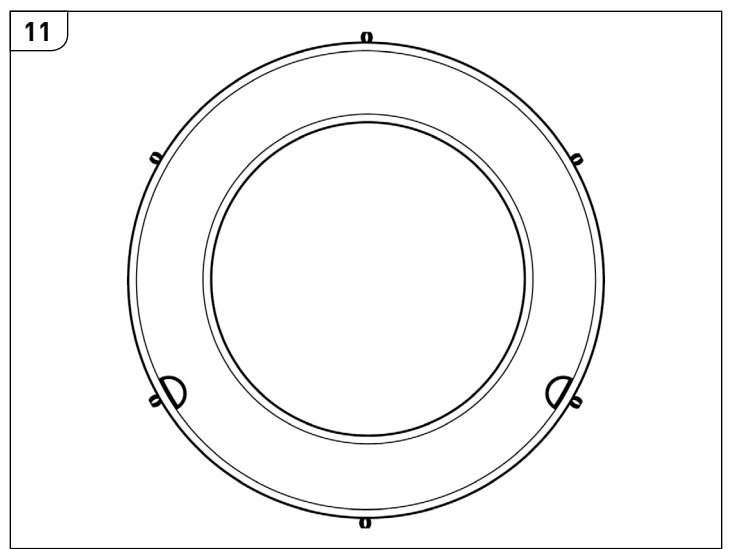
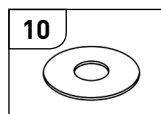
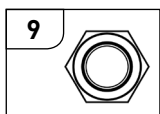
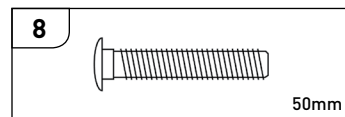
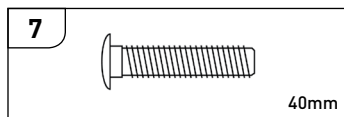
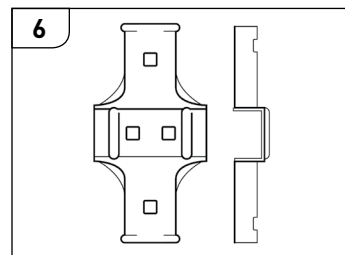
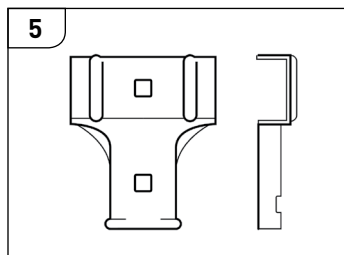
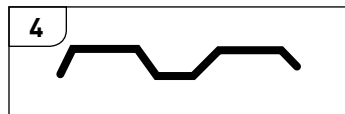
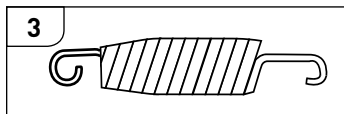
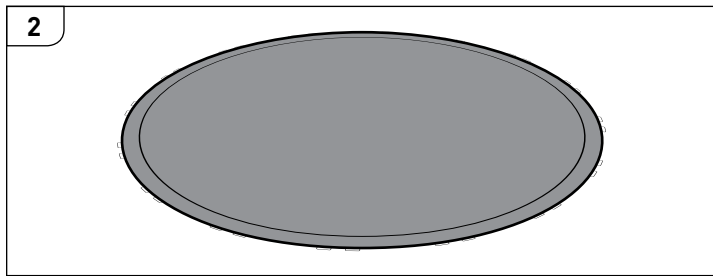
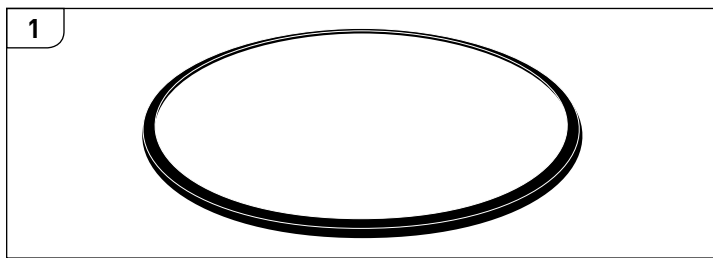

ASSEMBLY INSTRUCTIONS

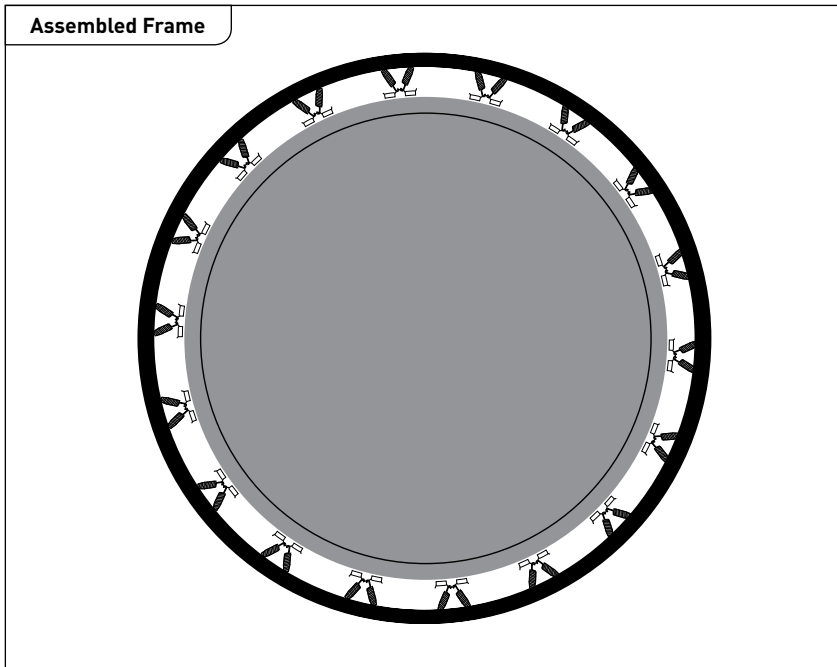

STEP 1:

NOTE:

The Frame Pad (Part 11) may be already attached to the Frame, remove it and place it aside until Step 4

The Frame (Part 1), Jumping Mat (Part 2), Springs (Part 3), & W-Hooks (Part 4) should be assembled in one piece.

Place assembled Frame on an even, clean, & flat surface to install. Make sure that there are no obstructions in your way when building the Mini Trampoline.

NOTE:

Make sure that the spring ends are facing up, and the logo printed on the Jumping Mat is facing the floor.

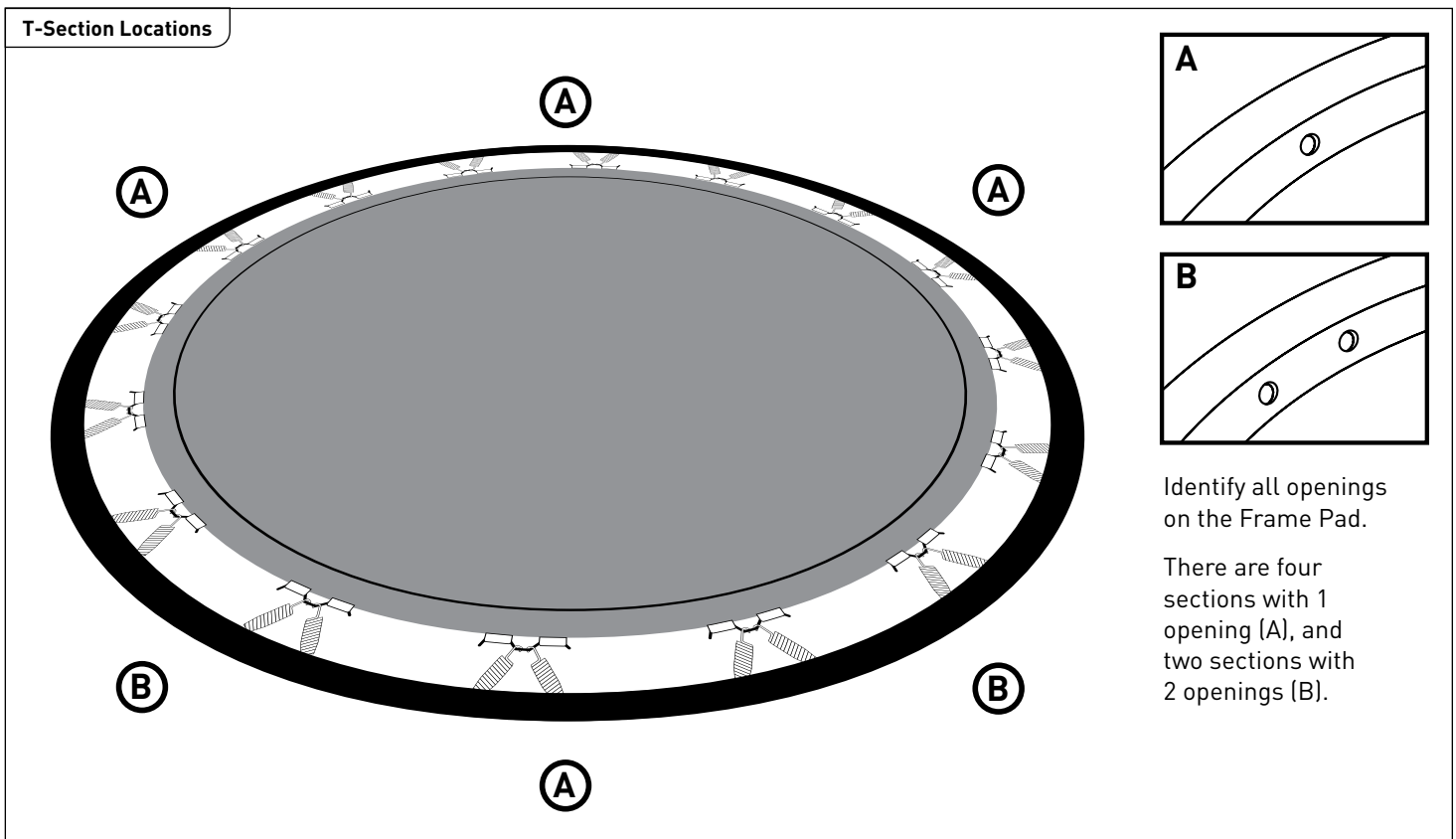

ASSEMBLY INSTRUCTIONS

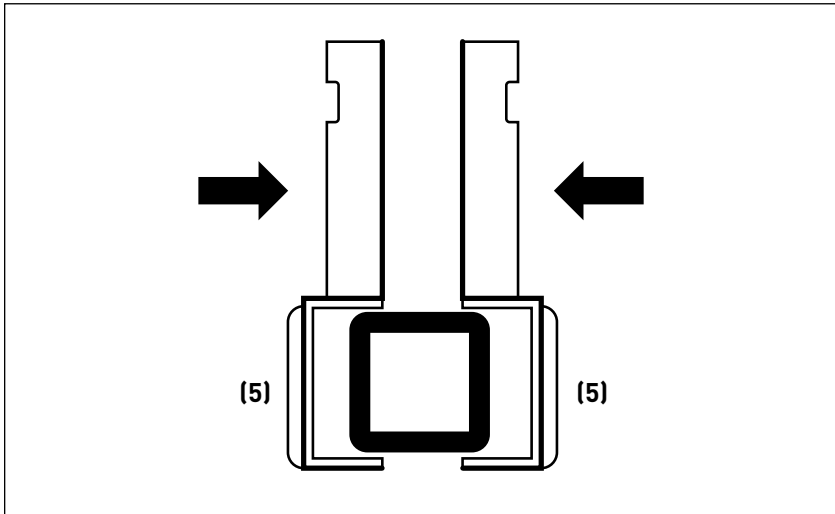

STEP 2:

Locate x8 T-Section Pieces (Part 5), x4 40mm Square Neck Bolts (Part 7), & x4 Nuts (Part 9).

Locate the (A) openings in the frame (Shown in page 8) to begin installing the T-Sections Pieces into the Frame.

A. Place a T-Section Piece on the outside of the frame and the other half from the inside of the Frame.

All openings should line up. Make sure that the T-Sections are facing up to install the legs in Step 6.

B. Insert a Bolt (Part 7) from the outside of the frame to show the smooth surface between both T-Section Pieces. Secure with a Nut (Part 9). Tighten loosely.

NOTE:

Make sure Bolt is fully inserted and the Nut is **not** fully tightened. This will help inserting the Legs in Step 6.

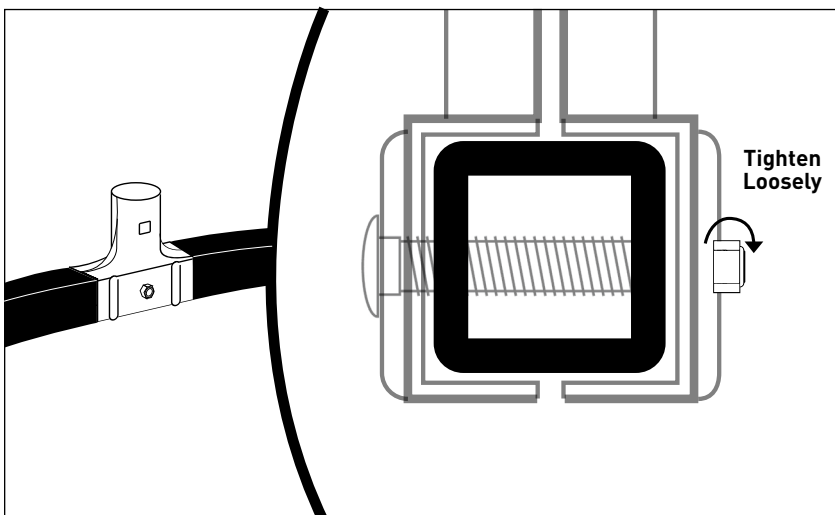
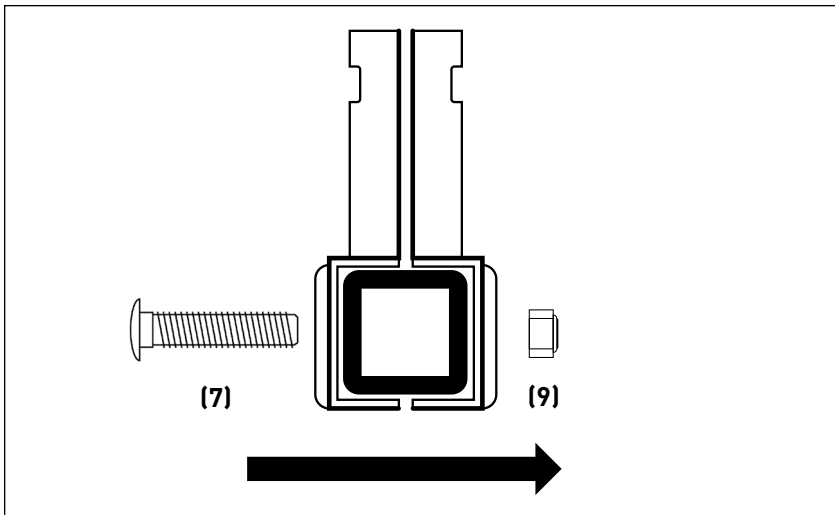

ASSEMBLY INSTRUCTIONS

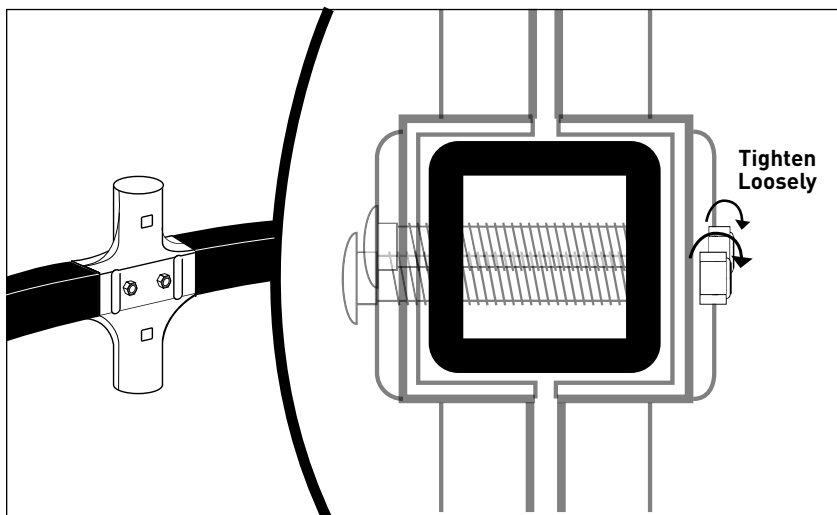
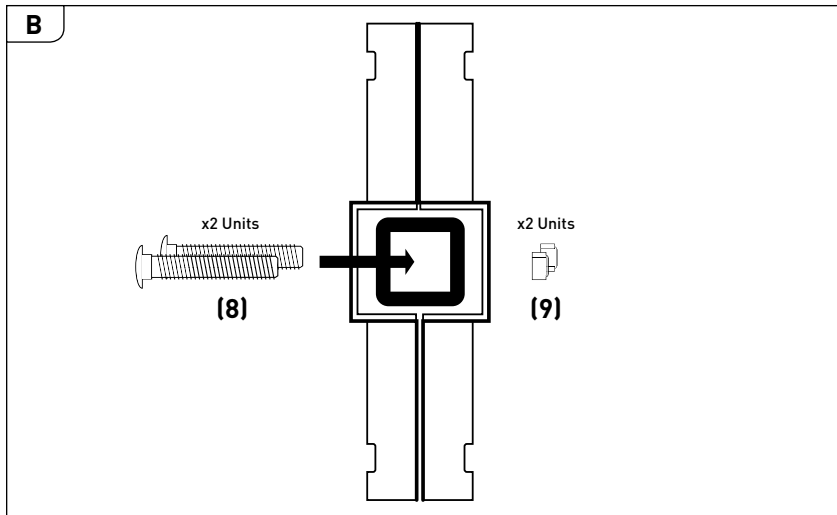
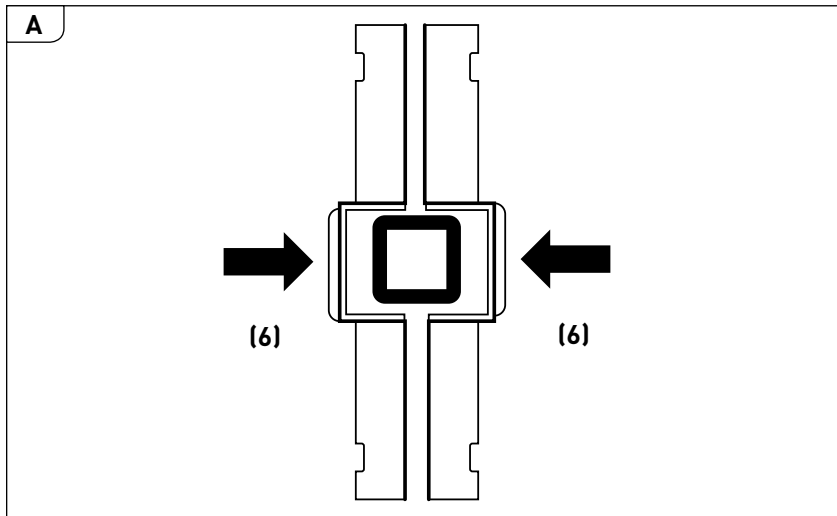

STEP 3:

Locate x4 Cross-Section Pieces (Part 6), x4 50mm Square Neck Bolts (Part 8), x4 Washers (Part 10), & x4 Nuts (Part 9).

Locate the (B) openings in the frame (Shown in page 8) to begin installing the Cross-Sections Pieces into the Frame.

A. Place a Cross-Section Piece on the outside of the frame and the other half from the inside of the Frame. All openings should line up.

B. Insert x2 Bolts (Part 8) from the outside of the frame to show the smooth surface between both Cross-Section Pieces. Secure both with a Nut (Part 9) on each one. Tighten loosely.

Repeat this process to assemble the second Cross-Section on the Frame.

NOTE:

Make sure Bolt is fully inserted and the Nut is **not** fully tightened. This will help inserting the Legs in Step 6.

ASSEMBLY INSTRUCTIONS

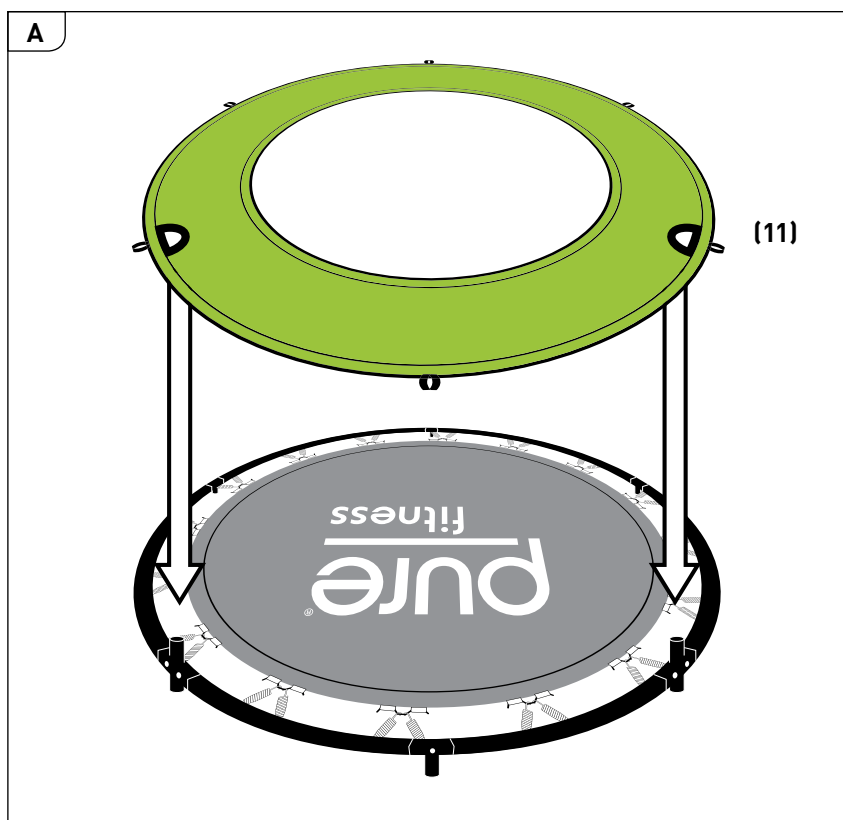

STEP 4:

A. Flip the Assembled Frame in order to place the Frame Pad (Part 11).

Make sure to locate all six loops in the Frame Pad, two of them should have two openings assigned for the Cross-Section Pieces. Place on top Frame to cover the Frame & Jumping Mat.

B. For the T-Sections, hook all loops in the inserts openings of the T-sections before installing the legs.

C. For the Cross-Sections, make sure both openings of the Cross-Section go inside the according hoops in the Frame Pad. Hook the loop into the bottom section of the Cross Section.

Once the Frame Pad is placed, flip the frame again so the Jump Mat faces the ground to begin installation of the legs.

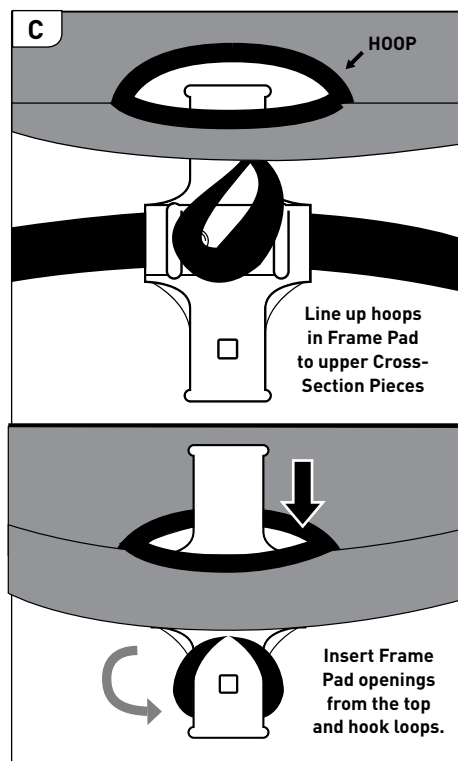
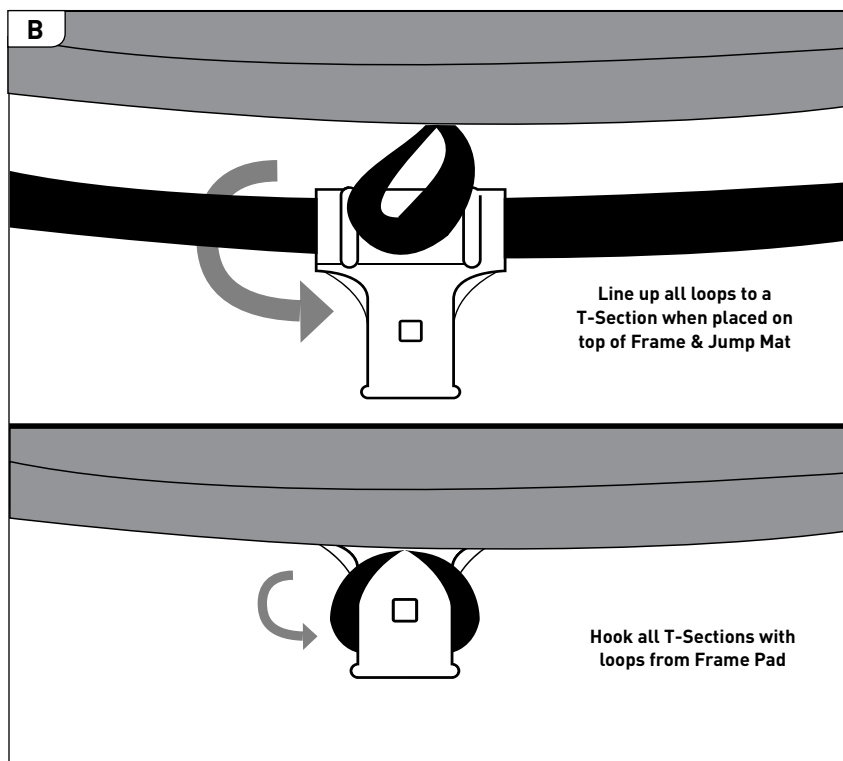

ASSEMBLY INSTRUCTIONS

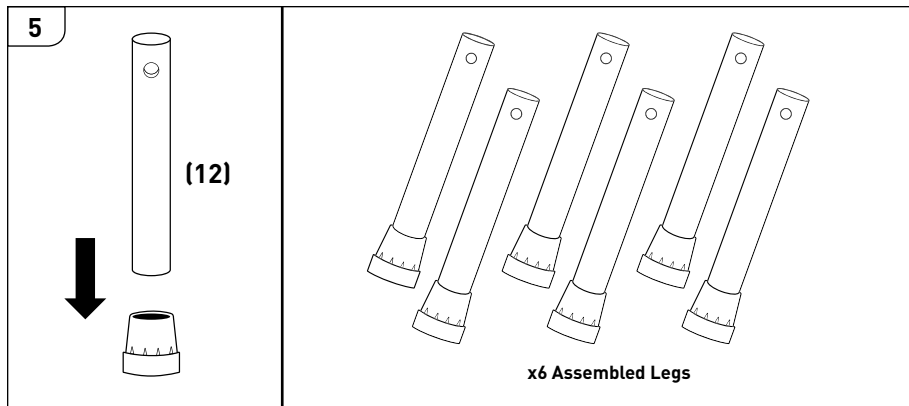

STEP 5:

Locate the following parts: x6 Legs with Caps (Part 12), x6 40mm Square Neck Bolts (Part 7), x6 Washers (Part 10), & x6 Nuts (Part 6).

NOTE:

If the Caps from the Leg Poles are not already placed after unboxing, make sure to insert them on the opposite side of where the openings are located as shown. This will make sure that the openings are clear when installing into the Frame. Repeat this process until you have all six assembled Legs with Caps.

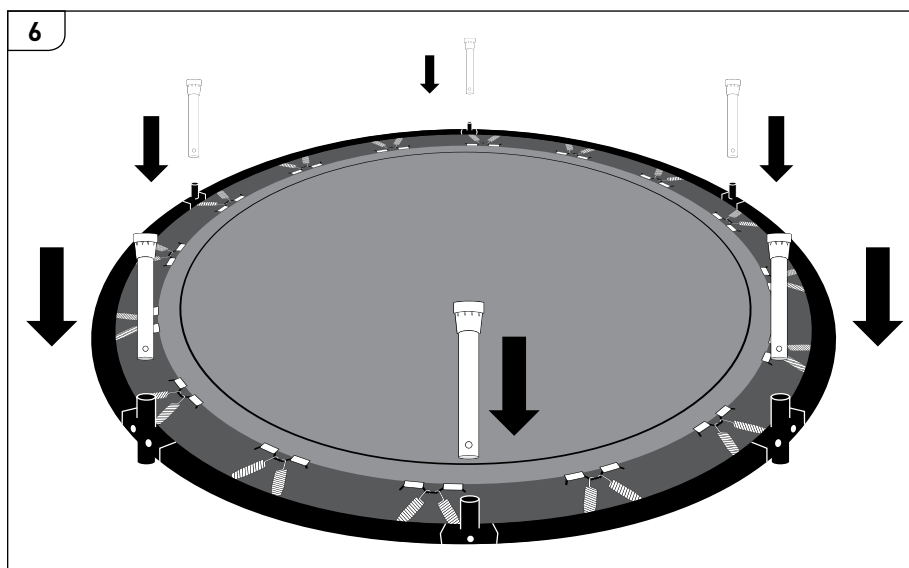

STEP 6:

Place all assembled legs inside the inserts. Align openings from the T-Sections & Cross-Sections to the Legs.

ASSEMBLY INSTRUCTIONS

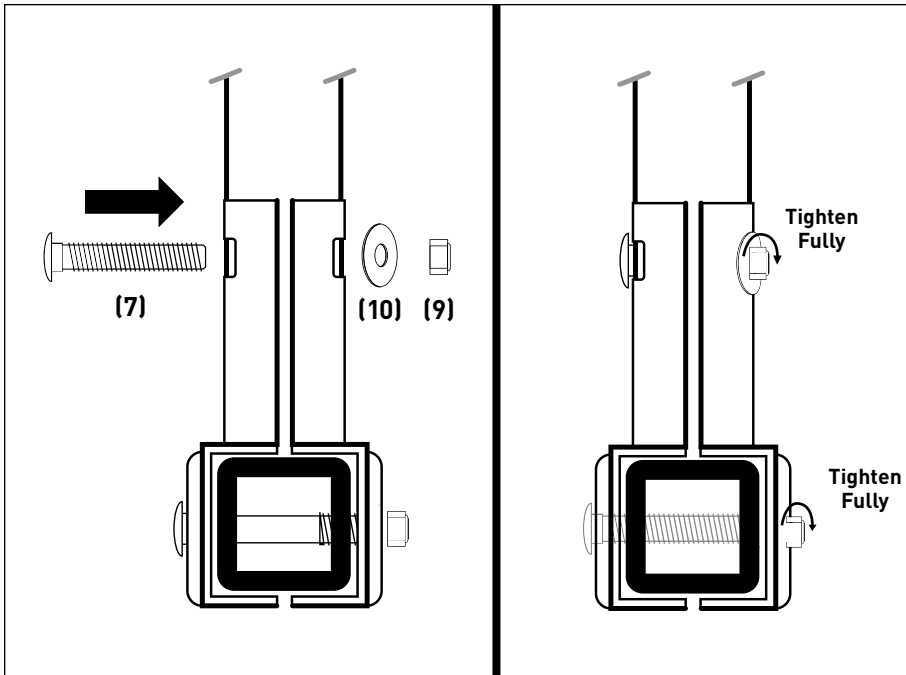

STEP 7:

- Insert a Bolt (Part 7) from the outside of the Frame and secure tightly with a Washer (Part 10), & Nut (Part 6). Make sure Bolt is fully inserted.
- Repeat this process until all legs in T-Sections are installed properly and securely.

NOTE:

Do not Tighten any Nuts from the Cross-Section Pieces. Doing so will make it difficult to install the Straight Poles (Part 9)

ASSEMBLY INSTRUCTIONS

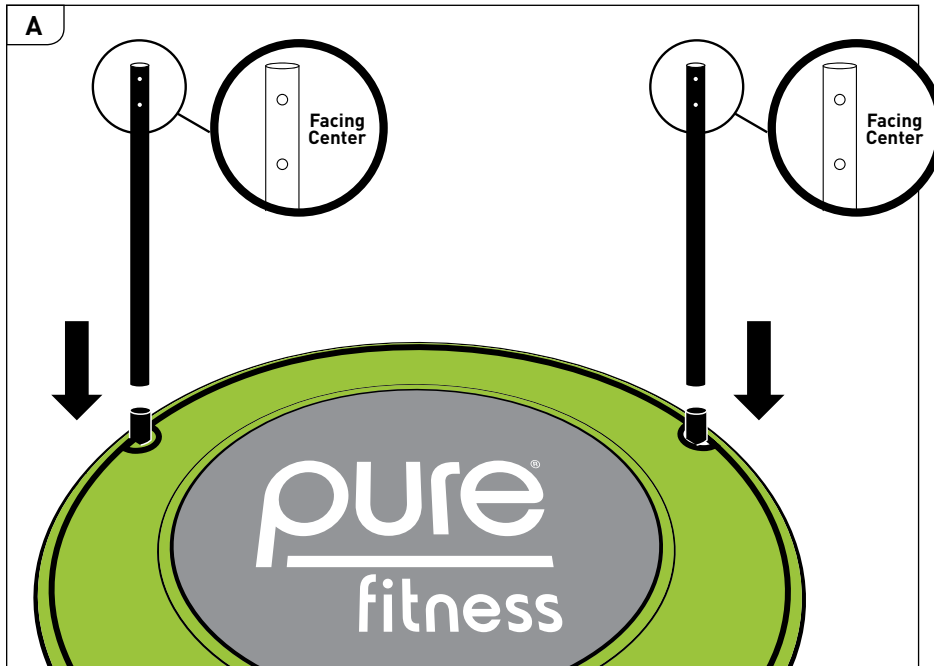

STEP 8:

A. Insert x2 Straight Poles (Part 13) into the upper openings of the Cross-Sections.

NOTE:

Straight poles upper openings must face the center of the trampoline.

B. Locate x2 40mm Square Neck Bolts (Part 7), x2 Washers (Part 10), and x2 Nuts (Part 9). Insert a Bolt from the inside facing out to each Straight Pole. Tighten both with a Washer & Nut.

NOTE:

If the Bolts are not inserted from the outside in, you leave yourself exposed to the sharp edges of the Nuts. Failure to do so can result in injury.

C. Once the bolts are inserted properly, tighten remainder of all nuts to secure the Straight Poles and Legs to the Cross-Section Pieces.

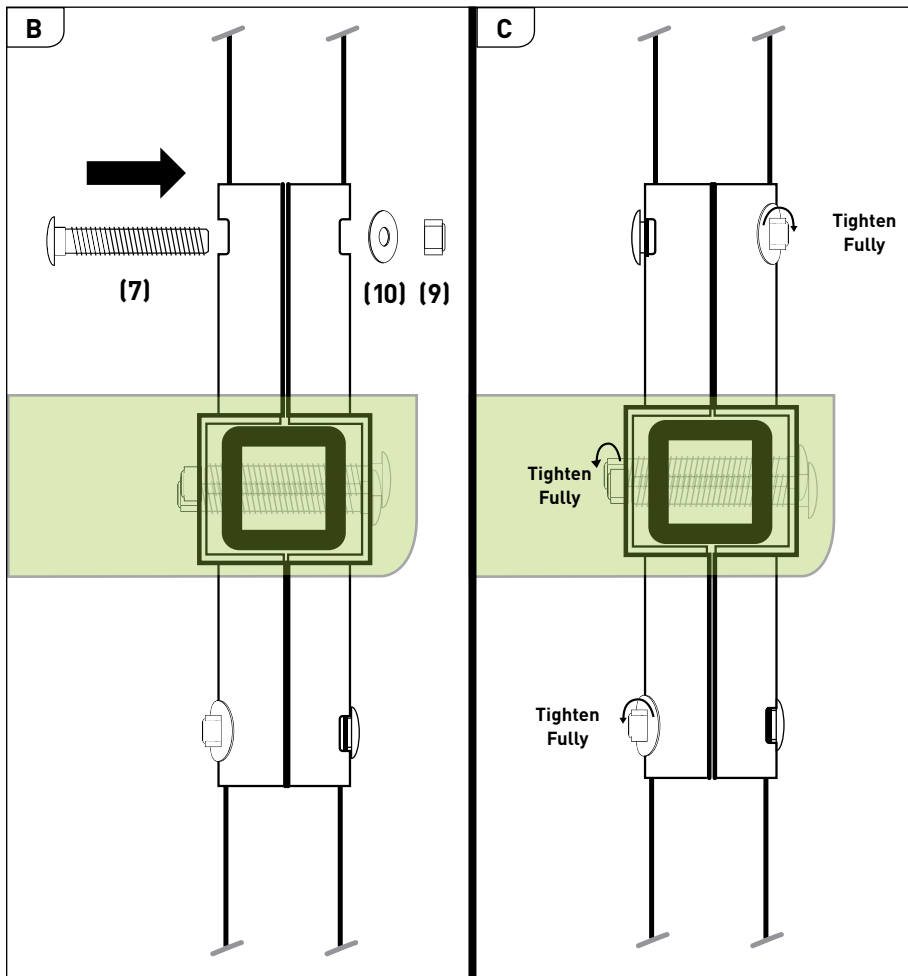

ASSEMBLY INSTRUCTIONS

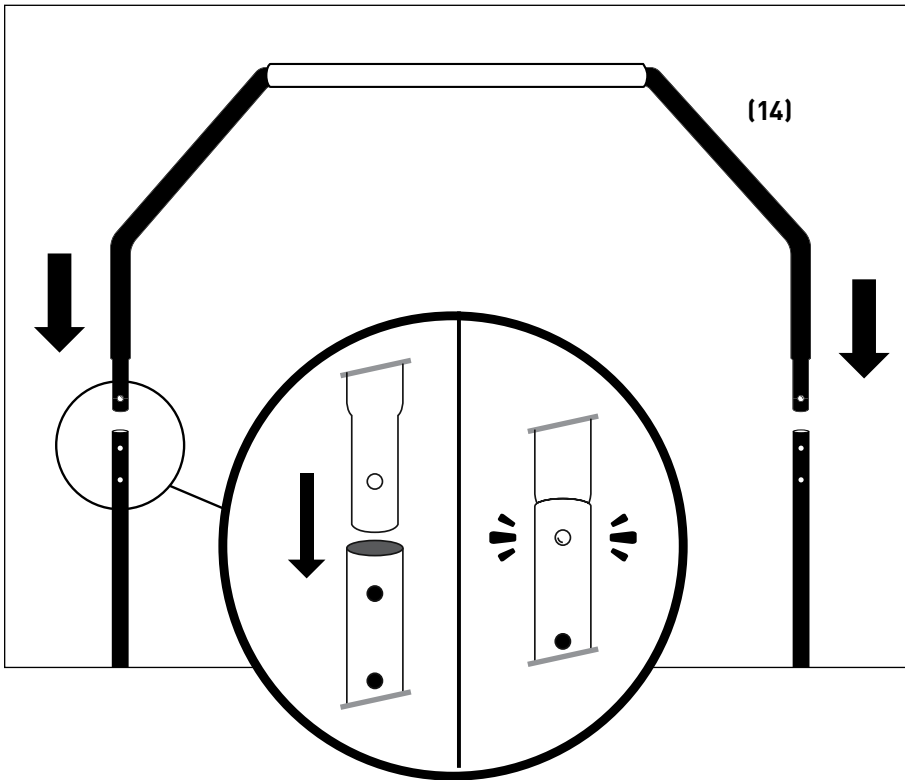

STEP 9:

Place Handle Bar with Foam Grip (Part 14) on top of Straight Poles. Both ends must be inserted at the same time.

Stop when you hear both the buttons Snap & Click in the openings.

To adjust to your desired height, simply press the buttons in and slide the pole to a desired opening.

IMPORTANT:

Handle Bar must be snapped on the same height for both openings. Failure to do this will cause the Poles to bend, snap, or break. Failure to do so may result in injury to the user.

FREQUENTLY ASKED QUESTIONS

- Question: "The Handle Bar is not aligned to the Straight Poles, I am unable to Snap & Click since they are not in position"

Answer: Loosen up the upper sections of the Cross-Section Pieces so you may be able to twist the Poles. The bottom opening is wider, which helps position the upper two openings properly. Once you do this, you should be able to insert the Handle Bar.

- Question: "When I am using the trampoline I feel the springs pinching my feet. How do I fix this?"

Answer: 1) There is a chance that the Frame Pad was installed the wrong way. The Spring ends should be facing the floor when in use. 2) When using the trampoline, remember to wear comfortable socks, jumping on the trampoline barefoot is unsafe.

- Question: "One of my trampoline legs has broken" or "The trampoline padding or mat is damaged, how do I replace it?"

Answer: If you are still within your warranty period (90 days from initial purchase) You should contact customer service and request more information.

- Question: "I had a part missing from my box" or "something was damaged during assembly, can you send it to me?"

Answer: If it has been 30 days or less from the date of your initial purchase, you can contact customer service for a replacement part to be issued.