

D105, D110, D125, D130, D140, D155, D160 and D170 John Deere Tractors



JOHN DEERE

OPERATOR'S MANUAL

John Deere Tractors D100 Series

OMGX25410 ISSUE H4 (ENGLISH)

CALIFORNIA

Proposition 65 Warning

Diesel engine exhaust and some of its constituents are known to the State of California to cause cancer, birth defects, and other reproductive harm.

If this product contains a gasoline engine:

WARNING

The engine exhaust from this product contains chemicals known to the State of California to cause cancer, birth defects or other reproductive harm.

The State of California requires the above two warnings.
Additional Proposition 65 Warnings can be found in this manual.

John Deere Power Products

North American Edition
Printed in U.S.A.



* S E L F *



* 0 M G X 2 5 4 1 0 *

Introduction

Thank You for Purchasing a John Deere Product

We appreciate having you as a customer and wish you many years of safe and satisfied use of your machine.

Using Your Operator's Manual

This manual is an important part of your machine and should remain with the machine when you sell it.

Reading your operator's manual will help you and others avoid personal injury or damage to the machine. Information given in this manual will provide the operator with the safest and most effective use of the machine. Knowing how to operate this machine safely and correctly will allow you to train others who may operate this machine.

If you have an attachment, use the safety and operating information in the attachment operator's manual along with the machine operator's manual to operate the attachment safely and correctly.

This manual and safety signs on your machine may also be available in other languages (see your authorized dealer to order).

Sections in your operator's manual are placed in a specific order to help you understand all the safety messages and learn the controls so you can operate this machine safely. You can also use this manual to answer any specific operating or servicing questions. A convenient index located at the end of this book will help you to find needed information quickly.

The machine shown in this manual may differ slightly from your machine, but will be similar enough to help you understand our instructions.

RIGHT-HAND and LEFT-HAND sides are determined by facing in the direction the machine will travel when going forward. When you see a broken line (-----), the item referred to is hidden from view.

Before delivering this machine, your dealer performed a predelivery inspection to ensure best performance.

Special Messages

Your manual contains special messages to bring attention to potential safety concerns, machine damage as well as helpful operating and servicing information. Please read all the information carefully to avoid injury and machine damage.



CAUTION: Avoid injury! This symbol and text highlight potential hazards or death to the operator or bystanders that may occur if the hazards or procedures are ignored.

IMPORTANT: Avoid damage! This text is used to tell the operator of actions or conditions that might result in damage to the machine.

NOTE: General information is given throughout the manual that may help the operator in the operation or service of the machine.

Contents

Contents

Introduction	2
Product Identification	3
Safety Labels—Text	5
Safety Labels—No Text	7
Safety	10
Machine Cleanout	16
Assembly	18
Operating Controls	20
Operating	22
Service Intervals	33
Service Lubrication	33
Service Engine	34
Service Transmission	39
Service Mower	39
Service Electrical	45
Service Miscellaneous	47
Troubleshooting	50
Storage	51
Specifications	52
Warranty	54
Getting Quality Service	56
Service Record	57
Slope Gauge	58

Product Identification

Record Identification Numbers

Lawn Tractors

D105, D110, D125, D130, D140, D155, D160, D170

PIN (F600001 -) - 49 State, Australia, Canada

PIN (F100001 -) - California

PIN (F300001) - Mexico, ROW

If you need to contact an Authorized Service Center for information on servicing, always provide the product model and identification numbers.

You will need to locate the product identification number (PIN) for the machine and engine serial number. Record the information in the spaces provided below.

DATE OF PURCHASE:

DEALER NAME:

DEALER PHONE:

PRODUCT IDENTIFICATION NUMBER:

ENGINE SERIAL NUMBER:

Machine Product Identification Number Location



GXAL41941—UN—04MAR13

Located on left side of frame

Original Instructions. All information, illustrations and specifications in this manual are based on the latest information available at the time of publication.

The right is reserved to make changes at any time without notice.

Product Identification

Engine Serial Number Location

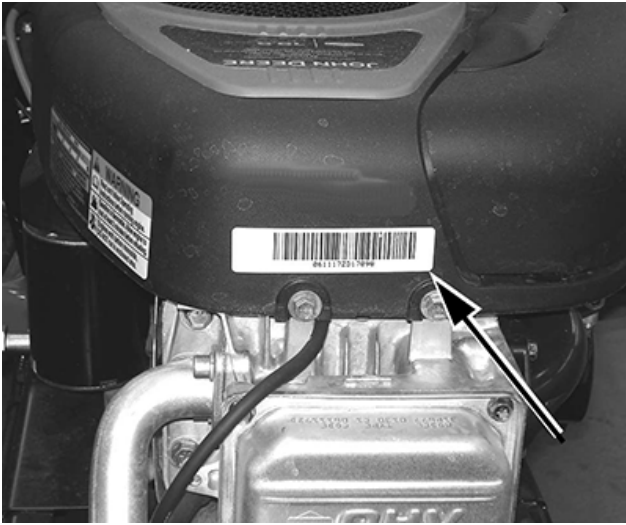

GXAL41942—UN—04MAR13

Single cylinder engines

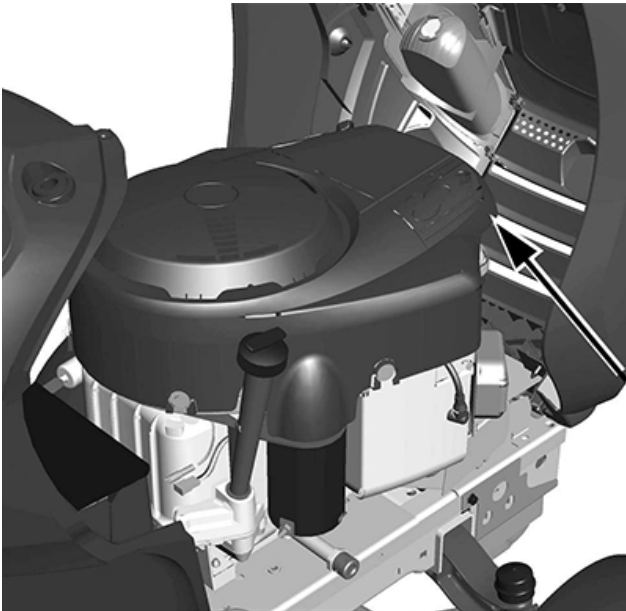

GXAL41943—UN—04MAR13

V-Twin engines

Register Your Product and Warranty Online

To register your product through the Internet, simply go to www.JohnDeereWarrantyRegistration.com. Completing the information, either online or with the product warranty card, will ensure the customer that their product receives all post sales service and important product information.

Safety Labels—Text

Safety Labels—Text

Safety Label Location (Text)

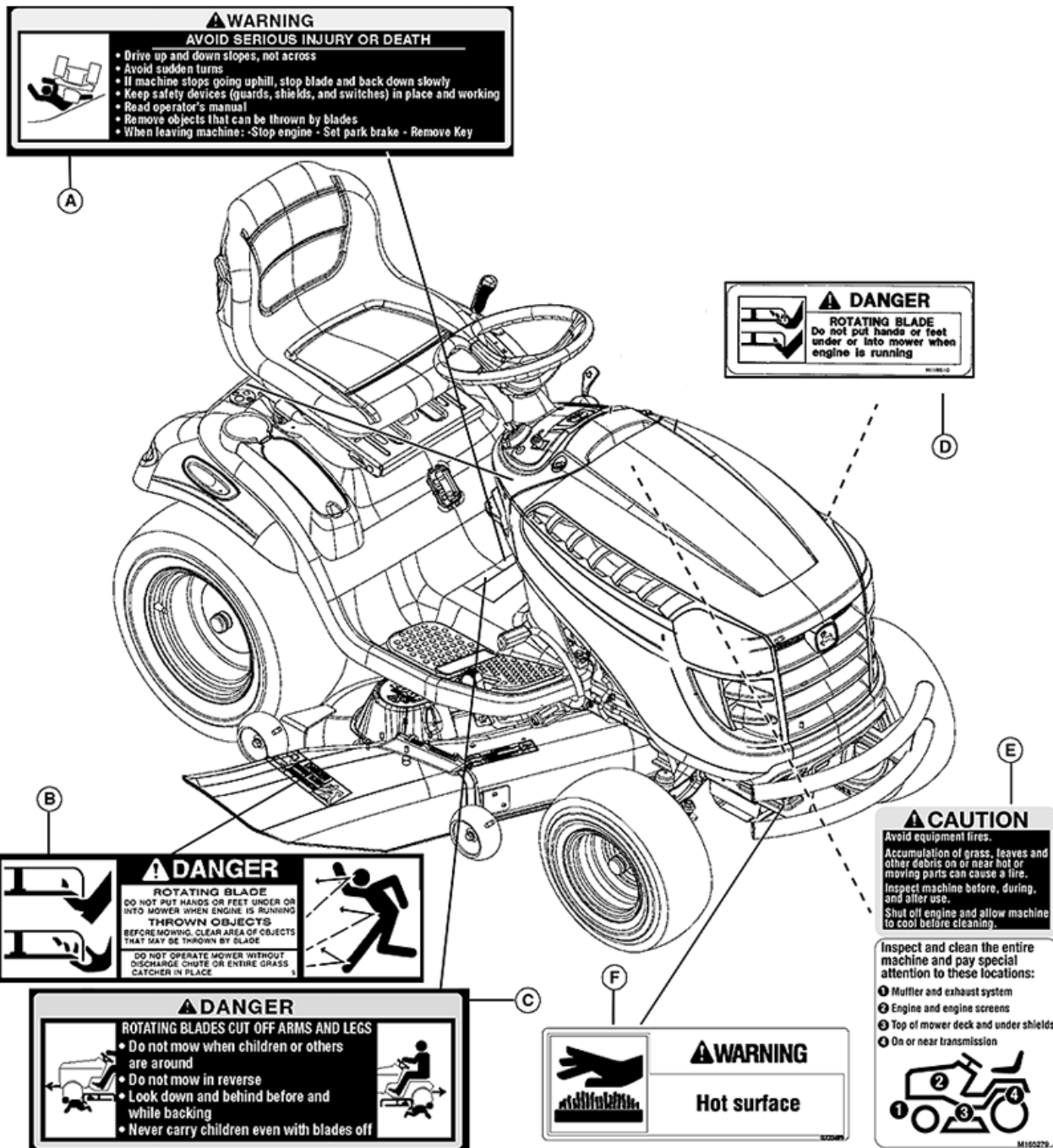

PY20028—UN—18FEB14

A — WARNING GX22477
 B — DANGER M89504
 C — DANGER GX22477

D — DANGER M118610
 E — CAUTION M165279
 F — WARNING GX23479

Safety Labels—Text

Understanding The Machine Safety Labels

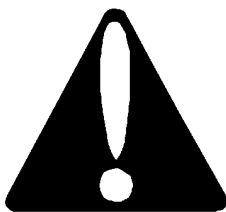

MXAL42363—UN—22MAY13

The machine safety labels shown in this section are placed in important areas on your machine to draw attention to potential safety hazards.

On your machine safety labels, the words DANGER, WARNING, and CAUTION are used with this safety-alert symbol. DANGER identifies the most serious hazards.

The operator's manual also explains any potential safety hazards whenever necessary in special safety messages that are identified with the word, CAUTION, and the safety-alert symbol.

Replace missing or damaged safety labels. Use this operator's manual for correct safety label placement.

There can be more safety information contained on parts and components sourced from suppliers that is not reproduced in this operator's manual.

French or Spanish Safety Labels and Operator's Manual

Operator's manuals and safety labels with content in French or Spanish are available for this machine through authorized John Deere dealers. See your John Deere dealer.

NOTE: Both text and no-text labels are shown. Your machine is only equipped with one of these types of labels.

DANGER



GXAL41947—UN—04MAR13

ROTATING BLADE

- Do not put hands or feet under or into mower when engine is running.

DANGER



GXAL41948—UN—04MAR13

ROTATING BLADE

- Do not put hands or feet under or into mower when engine is running.

THROWN OBJECTS

- Before mowing, clear area of objects that may be thrown by blade.

- Do not operate mower without discharge chute or entire grass catcher in place.

DANGER



GXAL41949—UN—04MAR13

ROTATING BLADES CUT OFF ARMS AND LEGS

- Do not mow when children or others are around.
- Do not mow in reverse.
- Look down and behind before and while backing.
- Never carry children even with blades off.

WARNING



GXAL41951—UN—04MAR13

AVOID SERIOUS INJURY OR DEATH

- Drive up and down slopes, not across.
- Avoid sudden turns.
- If machine stops going uphill, stop blades and back down slowly.
- Keep safety devices (guards, shields, and switches) in place and working.
- Remove objects that could be thrown by blades.
- Read operator's manual.
- Remove objects that can be thrown by blades
- When leaving machine:
 - Stop engine
 - Set park brake
 - Remove key

Avoid Injury From Hot Surface

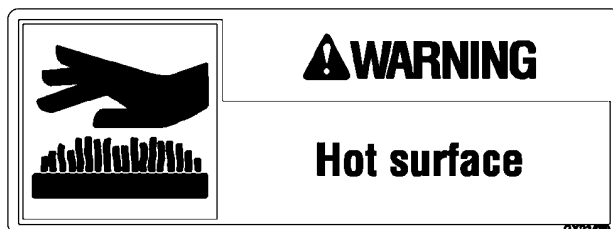

GXAL41952—UN—04MAR13

WARNING

- Hot surface

Safety Labels—No Text

Prevent Equipment Fires



GXAL41954—UN—04MAR13

- Avoid equipment fires.
- Accumulation of grass, leaves and other debris on or near hot or moving parts can cause a fire.
- Inspect machine before, during, and after use.
- Shut off engine and allow machine to cool before cleaning.

Inspect and clean the entire machine and pay special attention to these locations:

1. Muffler and exhaust system
2. Engine and engine screens
3. Top of mower deck and under shields
4. On or near transmission

Certification

Your mower has been certified for compliance with American National Standards Institute B-71.1-2012, "Safety Specifications" for Power Lawn Mowers, Lawn and Garden Tractors, and Lawn Tractors.

Canadian Electromagnetic Compatibility (EMC) Compliance

This spark ignition system complies with Canadian ICES-002.

Safety Labels—No Text

Safety Labels—No Text

Safety Label Location (No Text)

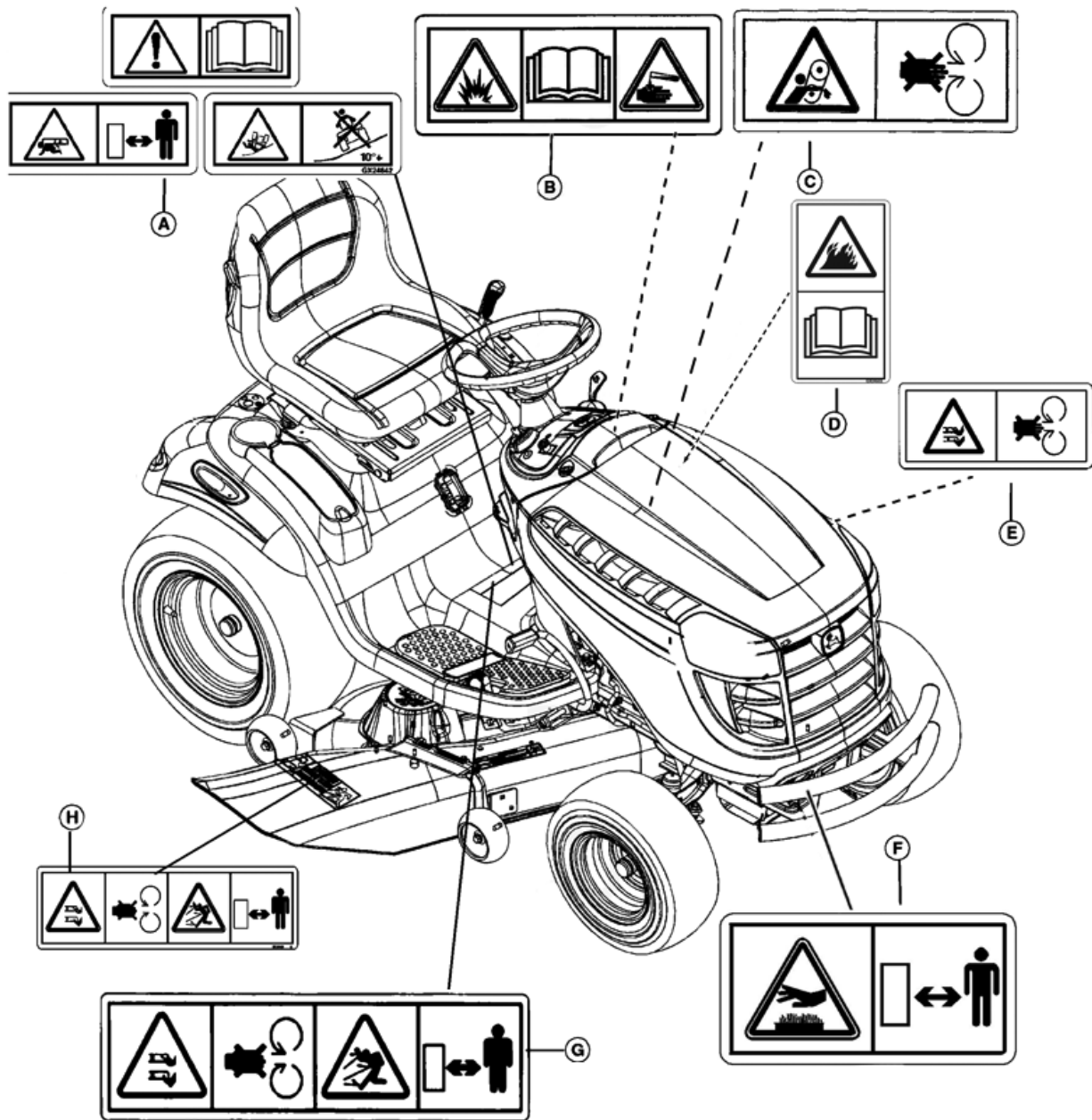

PY20029—UN—18FEB14

A — Read Operators Manual; Keep Children Away from Mower; Avoid Injury From Tipping - GX24842

B — Avoid Injury From Battery Gases and Acid - M128484

C — Avoid Injury From Getting Caught in Belt - M136436

D — Prevent Equipment Fires - GX24503

E — Avoid Injury From Rotating Blades - M118041

F — Avoid Injury From Hot Surfaces - GX25568

G — Avoid Injury From Rotating Blades and Thrown Objects - M148522

H — Avoid Injury From Rotating Blades and Thrown Objects - M118040

Safety Labels—No Text

Understanding The No-Text Machine Safety Labels



TCT005498—UN—11SEP12

At several important places on this machine safety signs are affixed intended to signify potential danger. The hazard is identified by a pictorial in a warning triangle. An adjacent pictorial provides information how to avoid personal injury. These safety signs, their placement on the machine and a brief explanatory text are shown in this Safety section.

There can be additional safety information contained on parts and components sourced from suppliers that is not reproduced in this operator's manual.

Read Operator's Manual

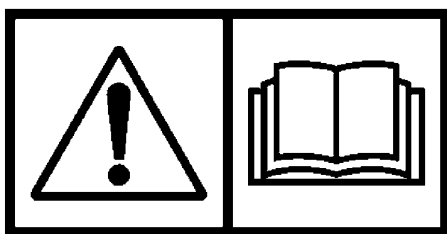

MXAL42776—UN—09APR13

- This operator's manual contains important information necessary for safe machine operation.
- Carefully read operator's manual before operating machine. Observe all safety rules to avoid accidents.

Keep Children Away from Mower

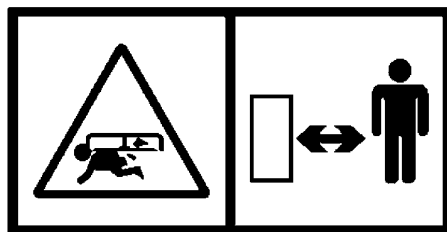

MXAL42778—UN—09APR13

- Mower can cause dismemberment or death.
- Stay a safe distance from the machine.
- Make sure that children stay clear of mower at all times when the engine is running.

Avoid Injury From Tipping

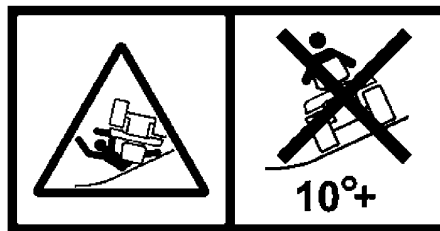

MXAL42779—UN—09APR13

- Do not drive where machine could slip, tip, or rollover.
- In some configurations, do not drive or operate on a slope of more than 10 degrees.
- Refer to the Operating on Slopes section for more information.

Avoid Injury From Thrown Objects

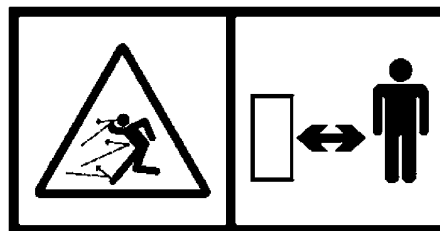

MXAL42780—UN—09APR13

- Keep a safe distance from the machine as long as the engine is running.

Avoid Injury From Getting Caught in Belts

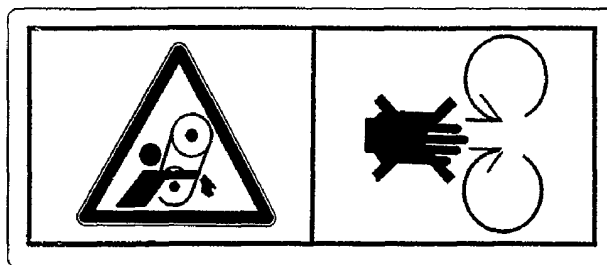

M136436—UN—24MAY13

- Stay clear of moving belts.
- Do not operate machine without shields in place.

Safety

Prevent Equipment Fires

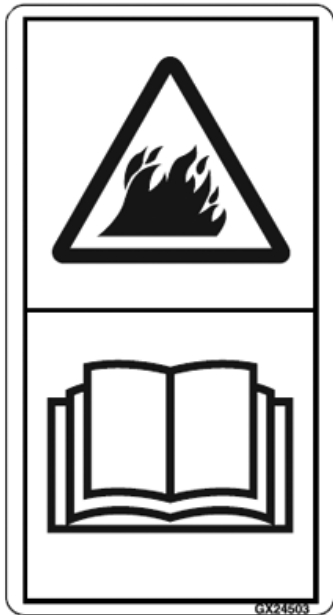

PY19036—UN—07AUG13

Clean and inspect the entire machine.

Carefully read Operator's Manual Machine Cleanout section for details.

Avoid Injury From Rotating Blades

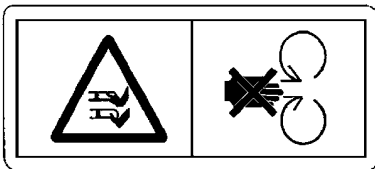

MXAL42784—UN—09APR13

- Do not put hands or feet under or into mower when engine is running.
- Do not operate mower without discharge chute or entire grass catcher in place.

Avoid Injury From Battery Gases and Acid

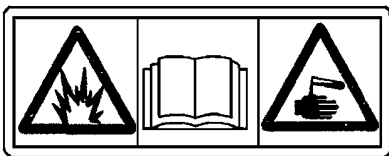

MXT007302—UN—23MAY13

- Shield eyes, explosive gases can cause blindness or injury.
- No sparks, flames, smoking.
- Sulfuric acid can cause blindness or severe burns.
- Keep out of the reach of children.
- Do not tip.
- Keep vent caps tight and level.
- Flush eyes immediately with water. Get medical help fast.

Avoid Injury from Hot Surfaces

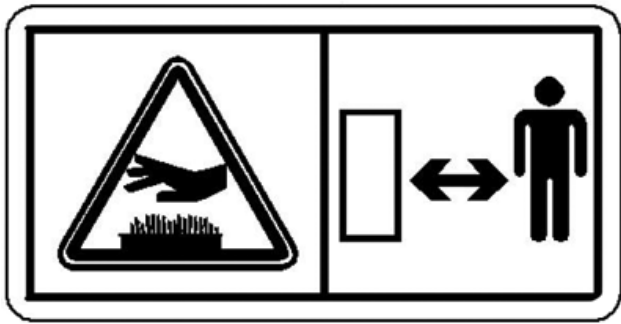

PY20032—UN—18FEB14

Warning - Hot Surfaces

- Keep away from hot surfaces.

Safety

Operating Safely



GXAL42347—UN—04MAR13

This cutting machine is capable of amputating hands and feet and throwing objects. Failure to observe the following safety instructions could result in serious injury or death.

- Read, understand and follow all instructions on the machine and in manuals provided, and view safety video, before starting. Be thoroughly familiar with the controls and the proper use of the machine before starting.
- Do not put hands or feet near rotating parts or under the machine. Keep clear of the discharge opening at all times.
- Only allow responsible adults, who are familiar with the instructions, to operate this machine. Local regulations may restrict the age of the operator.
- Clear the area of objects such as rocks, wire and toys which could be thrown by the blades.
- Be sure the area is clear of bystanders before operating. Stop machine if anyone enters the area.
- Never carry passengers.
- Do not mow in reverse unless absolutely necessary. Always look down and behind before and while backing.
- Never direct discharged material toward anyone. Avoid discharging material against a wall or obstruction. Material may ricochet back toward the operator. Stop the blades when crossing gravel surfaces.
- Do not operate the machine without the entire grasscatcher, discharge guard, or other safety devices in place and working. Never operate with the discharge deflector raised, removed, or altered, unless using a grasscatcher.
- Slow down before turning.
- Never leave a running machine unattended. Always turn off blades, lock park brake, stop engine and remove key before dismounting.
- Disengage blades when not mowing. Shut off engine and wait for all parts to come to a complete stop before cleaning the machine, removing the grasscatcher, or unclogging the discharge chute.

Safety

- Operate machine only in daylight or good artificial light.
- Do not operate the machine while under the influence of alcohol or drugs.
- Watch for traffic when operating near or crossing roadways. Stop blades before crossing roads or sidewalks.
- Use extra care when loading or unloading the machine into a trailer or truck.
- Always wear safety goggles or safety glasses with side shields when operating machine.
- Data indicates operators 60 years and above are involved in a large percentage of riding mower-related injuries. These operators should evaluate their ability to operate the riding mower safely enough to protect themselves and others from serious injury.
- Follow the manufacturer's recommendation for wheel weights or counterweights.
- Inspect machine before you operate. Be sure hardware is tight. Repair or replace damaged, badly worn, or missing parts. Be sure guards and shields are in good condition and fastened in place. Make any necessary adjustments before you operate.
- Before using, always visually inspect to see that the blades, blade bolts and the mower assembly are not worn and damaged. Replace worn and damaged blades and bolts in sets to preserve balance.
- Make sure spark plug, muffler, fuel cap and air cleaner are in place before starting the engine.
- Be sure all drives are in neutral and parking brake is locked before starting engine. Only start engine from the operator's position.
- Do not change the engine governor settings or overspeed the engine. Operating the engine at excessive speed can increase the hazard of personal injury.
- If you hit an object or if abnormal vibration occurs, stop the machine and inspect it. Make repairs before you operate.
- Use only accessories and attachments approved by the manufacturer of the machine. Keep safety labels visible when installing accessories and attachments.
- Do not wear radio or music headphones. Safe service and operation requires your full attention.
- When machine is left unattended, stored, or parked, lower the mower deck unless a positive mechanical lock is used.

Using a Spark Arrestor

The California Public Resources Code, section 4442.5 provides as follows:

No person shall sell, offer for sale, lease, or rent to any person any internal combustion engine subject to Section 4442 or 4443, and not subject to Section 13005 of the Health and Safety Code, unless the person provides a written notice to the purchaser or bailee, at the time of sale or at the time of entering into the lease or rental contract, stating that it is a violation of Section 4442 or 4443 to use or operate the engine on any forest-covered, brush-covered, or grass-covered land unless the engine is equipped with a spark arrestor, as defined in Section 4442, maintained in effective working order or the engine is constructed, equipped, and maintained for the prevention of fire pursuant to Section 4443. Cal. Pub. Res. Code 4442.5.

Other states or jurisdictions may have similar laws. A spark arrestor for your machine may be available from your authorized dealer. An installed spark arrestor must be maintained in good working order by the operator.

Checking Mowing Area



MXAL41932—UN—22MAY13

- Clear mowing area of objects that might be thrown. Keep people and pets out of mowing area.
- Low-hanging branches and similar obstacles can injure the operator or interfere with mowing operation. Before mowing, identify potential obstacles such as low-hanging branches, and trim or remove those obstacles.
- Study mowing area. Set up a safe mowing pattern. Do not mow where traction or stability is doubtful.
- Test drive area with mower lowered (if equipped) but not running. Slow down when you travel over rough ground.
- Survey all mowing sites to determine which slopes are safe for machine operation and which slopes should be maintained through other maintenance techniques.

Parking Safely

1. Stop machine on a level surface, not on a slope.
2. Disengage mower blades or any other attachments.
3. Lower attachments to the ground.
4. Lock the park brake.
5. Stop the engine.
6. Remove the key.
7. Wait for engine and all moving parts to stop before you leave the operator's seat.
8. Close fuel shut-off valve, if your machine is equipped.
9. Disconnect the negative battery cable or remove the spark plug wire(s) (for gasoline engines) before servicing the machine.

Rotating Blades are Dangerous



MXAL41928—UN—18FEB13

HELP PREVENT SERIOUS OR FATAL ACCIDENTS:

- Rotating blades can cut off arms and legs, and throw objects. Failure to observe safety instructions could result in serious injury or death.
- Keep hands, feet and clothing away from mower deck when engine is running.
- Be alert at all times, drive forward and in reverse carefully. People, especially children can move quickly into the mowing area before you know it.
- Before backing up, stop mower blades or attachments and look down and behind the machine carefully, especially for children.
- Do not mow in reverse.
- Shut off blades when you are not mowing.

Safety

- Park machine safely before leaving the operator's station for any reason including emptying the grasscatchers or unplugging the chute.
- The mower blades should stop in approximately five seconds when the mower is disengaged. If you believe that your blades may not be stopping in that period of time, take your machine to your authorized dealer where they can safely check and service your machine.

Protect Children

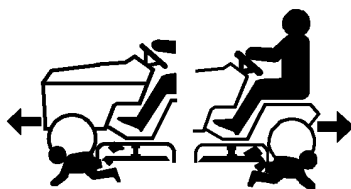

MXAL41929—UN—18FEB13

- Death or serious injury can occur when young children associate having fun with a lawn mowing machine simply because someone has given them a ride on a machine.
- Children are attracted to lawn mowing machines and mowing activities. They don't understand the dangers of rotating blades or the fact that the operator is unaware of their presence.
- Children who have been given rides in the past may suddenly appear in the mowing area for another ride and be run over or backed over by the machine.
- Tragic accidents with children can occur if the operator is not alert to the presence of children, especially when a child approaches a machine from behind. Before and while backing up, stop mower blades and look down and behind the machine carefully, especially for children.
- Never carry children on a machine or attachment, even with the blades off. Do not tow children in a cart or trailer. They can fall off and be seriously injured or interfere with safe machine operation.
- Never use the machine as a recreational vehicle or to entertain children.
- Never allow children or an untrained person operate the machine. Instruct all operators not to give children a ride on the machine or in an attachment.
- Keep children indoors, out of the mowing area, and in the watchful eye of a responsible adult, other than the operator, when a mower is being operated.
- Stay alert to the presence of children. Never assume that children will remain where you last saw them. Turn the machine off if a child enters the work area.
- Use extreme care when approaching blind corners, shrubs, trees, or other objects that may block your view of a child.

Operating on Slopes

NOTE: Remove Slope Gauge Template page from the back of this operators manual. Follow the instructions included with the template.

- Slopes are a major factor related to loss-of-control and tipover accidents, which can result in severe injury or death. Operation on all slopes requires extra caution.

Identify Slopes for Safe Operation

- Follow safe procedures for operation on slopes. Measure slopes of all moving sites to determine which slopes are safe for mowing with a ride-on mower. Always use common sense and good judgement when performing this survey.

Measuring Slopes

- Suggested Method 1: Lay a straight piece of sturdy lumber 1.2 m (4 ft) long on the slope and measure the angle of the slope with an angle indicator or protractor level.
- Suggested Method 2: Refer to the slope gauge provided at the end of this manual.

Operate Safely on Slopes

- Exceeding the recommended maximum slope angle increases the risk of rollover accidents that can result in serious injury or death.
- Never mow or operate ride-on mower on slope angles greater than 13° with the lawn ride-on mower in its basic configuration. The basic configuration is the ride-on mower with mower deck and not other attachments. (A 13° slope is a slope that rises 1.4 m (4.6 ft) over a horizontal distance of 6.1 m (20 ft).)
- When using attachments, never mow or operate the ride-on mower on slope angles greater than 10°. The addition of a weather enclosure, material collection system, or other attachments will increase the risk of a rollover. (A 10° slope is a slope that rises 1 m (3.5 ft) over a horizontal distance of 6.1 m (20 ft).)
- On slope angles of 10° or less, the risk of rollover is low, but as the slope angle increases to the recommended maximum, the risk increases to a medium level.
- Always consider potential turf conditions and slope angles when determining the risk of loss-of-control and tip-over accidents.
- Drive slowly when mowing or operating on slopes.
- If you feel uneasy on a hillside, do not mow or operate on it.
- Mow up and down slopes, not across.
- Watch for holes, ruts, bumps, rocks, or other hidden objects. Uneven terrain could overturn the ride-on mower. Tall grass can hide obstacles.
- Drive slowly so you will not have to stop while on a slope.
- Do not mow on wet grass. Tires may lose traction. Tires may slip on slopes even though the brakes are functioning properly.
- Avoid starting, stopping or turning on a slope. If the tires lose traction, disengage the PTO and proceed slowly, straight down the slope.
- Keep all movement on slopes slow and gradual. Do not make sudden changes in speed or direction, which could cause the ride-on mower to roll over.

Safety

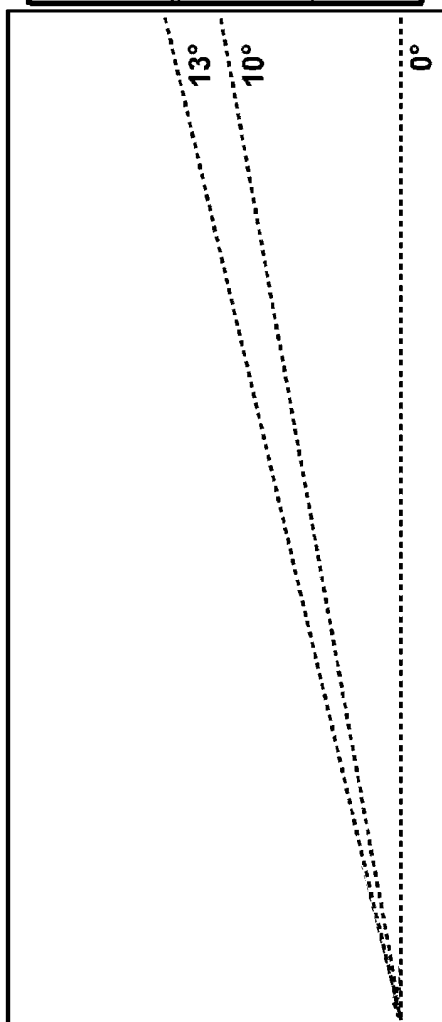
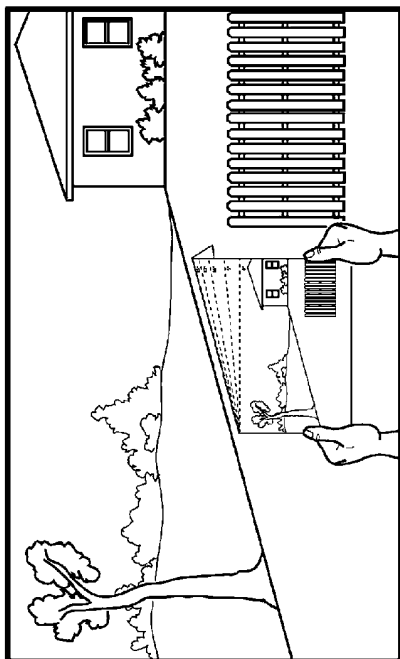

MXT005363—UN—10JUL13

Operating Near Hazards

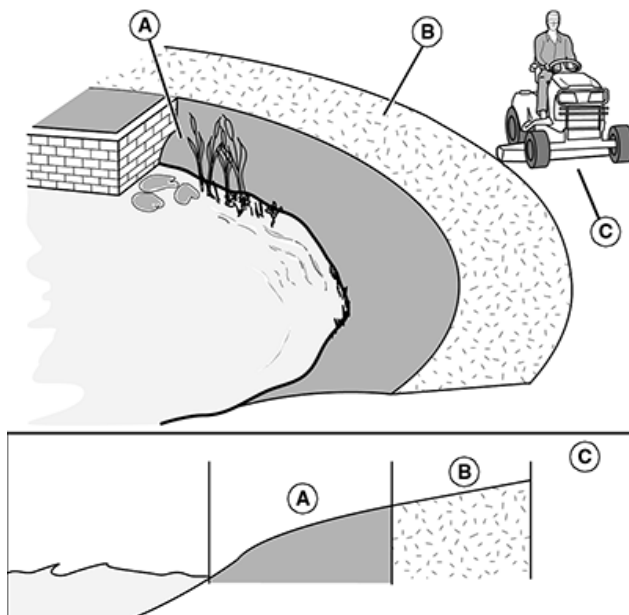

GXAL41966—UN—04MAR13

Example side view of slope and hazards, showing areas (A), (B), and (C).

- Do not mow or operate machine in areas adjacent to hazards that may cause the machine to roll over. The machine could suddenly lose traction, slide, and/or roll over if a wheel goes over the edge or if the edge breaks away.
- Hazards (A) include but are not limited to:
 - Drop-offs, ditches, embankments, or bodies of water.
 - Areas of unsafe slope, soft ground, edges along bodies of water, or area with holes, ruts, bumps, or other hidden objects.
- Maintain a buffer area (B) at least as wide as the machine between hazards (A) and the mowing area (C). Do not mow or operate the machine in the hazard area or buffer area.
- Only mow or operate the machine in the mowing area (C). Do not exceed the recommended slope operating angle. Refer to the "Operate Safely on Slopes" section.
- Use a walk-behind mower or string trimmer in and around areas (A) and (B).

Keep Riders Off



MXAL41930—UN—18FEB13

- Only allow the operator on the machine. Keep riders off.
- Riders on the machine or attachment may be struck by foreign objects or thrown off the machine causing serious injury.
- Riders obstruct the operator's view resulting in the machine being operated in an unsafe manner.

Towing Loads Safely

- Stopping distance increases with speed and weight of towed load. Travel slowly and allow extra time and distance to stop.
- Total towed weight must not exceed combined weight of pulling machine, ballast and operator. Use counterweights or wheel weights as described in the attachment or pulling machine operator's manual.

Safety

- Excessive towed load can cause loss of traction and loss of control on slopes. Reduce towed weight when operating on slopes.
- Never allow children or others in or on towed equipment.
- Use only approved hitches. Tow only with a machine that has a hitch designed for towing. Do not attach towed equipment except at the approved hitch point.
- Follow the manufacturer's recommendations for weight limits for towed equipment and towing on slopes.
- Towed attachments will increase the risk of rollover. Refer to the "Operating on Slopes" section for more information.
- Do not turn sharply. Use additional caution when turning or operating under adverse surface conditions. Use care when reversing.
- Do not shift to neutral and coast downhill.

Wear Appropriate Clothing



MXAL41935—UN—18FEB13

- Always wear eye protection when operating the machine.
- Wear close fitting clothing and safety equipment appropriate for the job.
- While operating this machine, always wear substantial footwear and long trousers. Do not operate the equipment when barefoot or wearing open sandals.
- Wear a suitable protective device such as earplugs. Loud noise can cause impairment or loss of hearing.

Driving Safely on Public Roads



MXAL42880—UN—26MAR13

Avoid personal injury or death resulting from a collision with another vehicle on public roads:

- Use safety lights and devices. Slow moving machines when driven on public roads are hard to see, especially at night.
- Whenever driving on public roads, use flashing warning lights and turn signals according to local regulations. Extra flashing warning lights may need to be installed.

Practice Safe Maintenance



MXAL41933—UN—18FEB13

- Only qualified, trained adults should service this machine. Understand service procedure before doing work.
- Never operate machine in a closed area where dangerous carbon monoxide fumes can collect.
- Keep all nuts and bolts tight, especially blade attachment bolts, to be sure the equipment is in safe working condition.

- Never tamper with safety devices. Check their proper operation regularly.
- Keep machine free of grass, leaves or other debris build-up. Clean up oil or fuel spillage and remove any fuel-soaked debris. Allow the machine to cool before storing.
- If you strike a foreign object, stop and inspect the machine. Repair, if necessary, before restarting.
- Never make any adjustments or repairs with the engine running. Wait for all movement to stop on machine before adjusting, cleaning or repairing.
- Check grasscatcher components and the discharge guard frequently and replace with manufacturer's recommended parts, when necessary. Grasscatcher components are subject to wear, damage, and deterioration which could expose moving parts or allow objects to be thrown.
- Mower blades are sharp. Wrap the blade or wear gloves, and use extra care when servicing them. Only replace blades. Never straighten or weld them.
- Check brake operation frequently. Adjust and service as required.
- Maintain or replace safety and instruction labels, as necessary.
- On multi-bladed machines, take care as rotating one blade can cause other blades to rotate.
- Keep hands, feet, clothing, jewelry, and long hair away from any moving parts, to prevent them from getting caught.
- Lower any attachments to the ground before cleaning or servicing machine. Disengage all power and stop the engine. Lock park brake and remove the key. Let machine cool.
- Securely support any machine elements that must be raised for service work. Use jack stands or lock service latches to support components when needed.
- Disconnect battery or remove spark plug wire (for gasoline engines) before making any repairs. Disconnect negative terminal first and positive last. Install positive terminal first and negative last.
- Before servicing machine or attachment, carefully release pressure from any components with stored energy, such as hydraulic components or springs.
- Keep all parts in good condition and properly installed. Fix damage immediately. Replace worn or broken parts.
- Charge batteries in an open, well-ventilated area, away from sparks. Unplug battery charger before connecting or disconnecting from the battery. Wear protective clothing and use insulated tools.
- Do not strike the flywheel with a hammer or hard object because the flywheel may later shatter during operation.
- If equipped with hydraulic lift - release hydraulic pressure by lowering attachment or cutting units to the ground or to a mechanical stop and move hydraulic control levers back and forth.

Avoid High Pressure Fluids



MXAL41927—UN—18FEB13

- Hydraulic hoses and lines can fail due to physical damage, kinks, age, and exposure. Check hoses and lines regularly. Replace damaged hoses and lines.
- Hydraulic fluid connections can loosen due to physical damage and vibration. Check connections regularly. Tighten loose connections.
- Escaping fluid under pressure can penetrate the skin causing serious injury. Avoid the hazard by relieving pressure before disconnecting hydraulic or other lines. Tighten all connections before applying pressure.
- Search for leaks with a piece of cardboard. Protect hands and body from high pressure fluids.

Safety

- If an accident occurs, see a doctor immediately. Any fluid injected into the skin must be surgically removed within a few hours or gangrene may result. Doctors unfamiliar with this type of injury should reference a knowledgeable medical source. Such information is available from Deere & Company Medical Department in Moline, Illinois, U.S.A. Information may be obtained in the United States and Canada only by calling 1-800-822-8262.

Prevent Fires

- Please review these recommendations with all operators. See your John Deere dealer with questions.
- Always follow all safety procedures posted on the machine and in this operator manual. Before carrying out any inspection or cleaning always shut off engine, set parking brake and remove ignition key.
- Besides routine maintenance, one of the best ways to keep your John Deere equipment running efficiently and to reduce fire risk is to regularly remove debris buildup from the machine.
- After operating, allow machine to cool in an open area before cleaning or storing. Do not park machine near flammable materials such as wood, cloth or chemicals, or near an open flame or other sources of ignition, such as a water heater or furnace.
- Completely remove any combustible materials from equipment before storing, by emptying any grass catcher bags, containers and cargo boxes.
- Debris can accumulate anywhere on the machine, especially on horizontal surfaces. Remove grass and debris completely from engine compartment, muffler area, and from on top of the mower deck both before and after operating machine. Additional cleaning may be necessary when mowing or mulching in dry conditions.
- In addition to cleaning machine before using and storing, keeping engine area clean will provide the greatest impact on fire prevention. Other areas requiring regular inspection and cleaning include behind wheel rims, wire harness, hose/line routings, mowing attachments, etc. Compressed air, leaf blowers or high pressured water can assist keeping these areas clean.
- Frequency of these inspections and cleaning will vary depending on a number of factors including operating conditions, machine configuration, operating speeds and weather conditions particularly dry, hot and windy conditions. When you are operating in these conditions, inspect and clean these areas frequently throughout the day.
- Excess lubrication or fuel/oil leaks or spills on the machine can also serve as collection sites for debris. Prompt machine repair and oil/fuel clean-up will reduce the potential for debris collection.
- Bearing failures or overheating can result in a fire. To reduce this risk, always follow the instructions in the machine operator's manual regarding lubrication intervals and locations. Contact your local dealer if you have any questions about the lubrication intervals or location and if any unusual noises are coming from areas where bearings might be located. Washing the machine while warm may also reduce bearing life and increase potential for premature bearing failure.
- Always shut off fuel when storing or transporting machine, if the machine has a fuel shutoff.
- Check fuel lines, tank, cap, and fittings frequently for cracks or leaks. Replace if necessary.

Handling Fuel Safely



MXAL41938—UN—18FEB13

To avoid personal injury or property damage, use extreme care in handling fuel. Fuel is extremely flammable and fuel vapors are explosive:

- Extinguish all cigarettes, cigars, pipes, and other sources of ignition.
- Use only an approved fuel container. Use only non-metal, portable fuel containers approved by the Underwriter's Laboratory (U.L.) or the American Society for Testing & Materials (ASTM). If using a funnel, make sure it is plastic and has no screen or filter.
- Never remove the fuel tank cap or add fuel with the engine running. Allow engine to cool before refueling.
- Never add fuel to or drain fuel from the machine indoors. Move machine outdoors and provide adequate ventilation.
- Clean up spilled fuel immediately. If fuel is spilled on clothing, change clothing immediately. If fuel is spilled near machine, do not attempt to start the engine but move the machine away from the area of spillage. Avoid creating any source of ignition until fuel vapors have dissipated.
- Never store the machine or fuel container where there is an open flame, spark, or pilot light such as on a water heater or other appliance.
- Prevent fire and explosion caused by static electric discharge. Static electric discharge can ignite fuel vapors in an ungrounded fuel container.
- Never fill containers inside a vehicle or on a truck or trailer bed with a plastic liner. Always place containers on the ground away from your vehicle before fueling.
- Remove fuel-powered equipment from the truck or trailer and refuel it on the ground. If this is not possible, then refuel such equipment with a portable container, rather than from a fuel dispenser nozzle.
- Keep the nozzle in contact with the rim of the fuel tank or container opening at all times until the fueling is complete. Do not use a nozzle lock-open device.
- Never overfill fuel tank. Replace fuel tank cap and tighten securely.
- Replace all fuel container caps securely after use.
- For gasoline engines, do not use gas with methanol. Methanol is harmful to your health and to the environment.

Tire Safety



MXAL41937—UN—18FEB13

Explosive separation of a tire and rim parts can cause serious injury or death:

- Do not attempt to mount a tire without the proper equipment and experience to perform the job.

Machine Cleanout

- Always maintain the correct tire pressure. Do not inflate the tires above the recommended pressure. Never weld or heat a wheel and tire assembly. The heat can cause an increase in air pressure resulting in a tire explosion. Welding can structurally weaken or deform the wheel.
- When inflating tires, use a clip-on chuck and extension hose long enough to allow you to stand to one side and NOT in front of or over the tire assembly.
- Check tires for low pressure, cuts, bubbles, damaged rims or missing lug bolts and nuts.

Checking Wheel Hardware

- A serious accident could occur causing serious injury if wheel hardware is not tight.
- Check wheel hardware tightness often during the first 100 hours of operation.
- Wheel hardware must be tightened to specified torque using the proper procedure anytime it is loosened.

Handling Waste Product and Chemicals

Waste products, such as, used oil, fuel, coolant, brake fluid, and batteries, can harm the environment and people:

- Do not use beverage containers for waste fluids - someone may drink from them.
- See your local Recycling Center or authorized dealer to learn how to recycle or get rid of waste products.
- A Material Safety Data Sheet (MSDS) provides specific details on chemical products: physical and health hazards, safety procedures, and emergency response techniques. The seller of the chemical products used with your machine is responsible for providing the MSDS for that product.

- Excess lubrication or fuel/oil leaks or spills on the machine can also serve as collection sites for debris. Prompt machine repair and oil/fuel cleanup will minimize the potential for debris collection and reduced cooling throughout machine life.
- Bearing failures or overheating can result in a fire. To reduce this risk, always follow the instructions in the machine operator's manual regarding lubrication intervals and locations. Washing the machine while warm may also reduce bearing life and increase potential for premature bearing failure.
- Always shut off fuel when storing or transporting machine, if the machine has a fuel shutoff.

Cleanout Areas

Primary areas that must be inspected and cleaned on the machine include (See Safety Label Section):

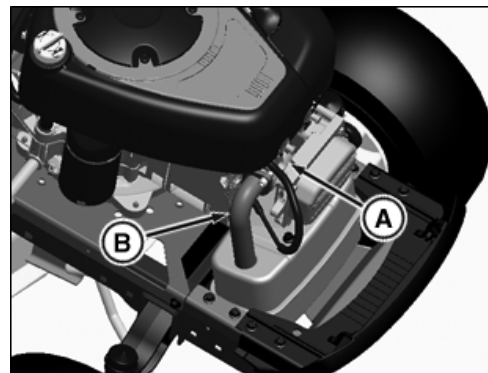

PY19189—UN—26JAN14

Machine Cleanout

Prevent Fires

- Besides routine maintenance, one of the best ways to keep your John Deere equipment running efficiently and to reduce fire risk is to regularly remove debris buildup from the machine.
- Please review these recommendations with all operators. See your John Deere dealer with questions.
- Always follow all safety procedures posted on the machine and in this operator manual. Before carrying out any inspection or cleaning, always shut off engine, set parking brake and remove ignition key.
- After operating, allow machine to cool in an open area before cleaning or storing. Do not park machine near flammable materials such as wood, cloth or chemicals.
- Empty any grasscatcher bags or containers completely before storing.
- Frequency of these inspections and cleaning will vary depending on a number of factors including operating conditions, machine configuration, operating speeds and weather conditions particularly dry, hot and windy conditions. When you are operating in these conditions, inspect and clean these areas frequently throughout the day.
- Wind direction, terrain type and moisture content of surrounding vegetation can effect where and how much debris accumulates.
- Debris can accumulate anywhere on the machine, especially on horizontal surfaces.
- Keeping engine area clean will provide the greatest impact on fire prevention. Other areas requiring regular inspection and cleaning include behind wheel rims, wire harness, hose/line routings, mowing attachments, etc. Compressed air, leaf blowers or high pressured water can assist keeping these areas clean.

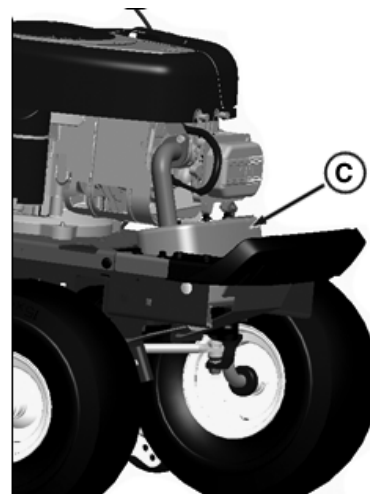

PY19190—UN—26JAN14

Machine Cleanout

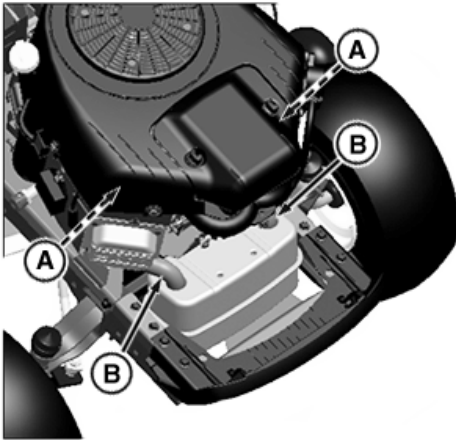

PY19191—UN—26JAN14

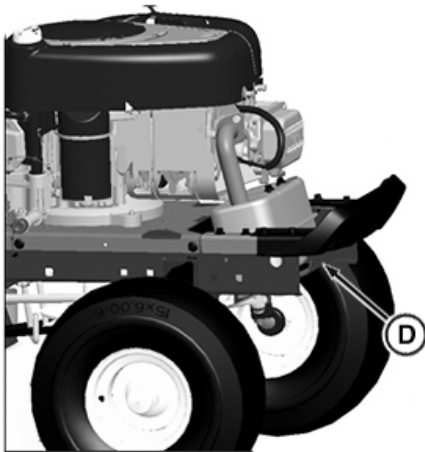

PY19178—UN—23JAN14

1. Exhaust manifold (A), muffler pipe (B), muffler (C) and muffler shield (D).

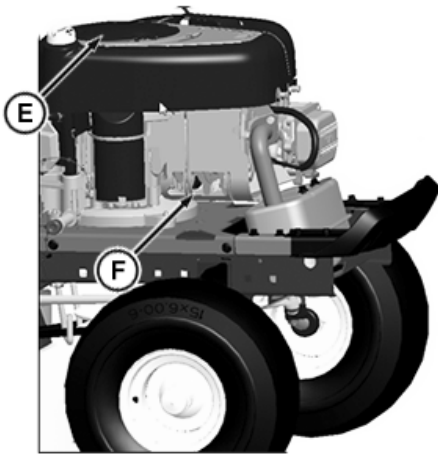

PY19192—UN—26JAN14

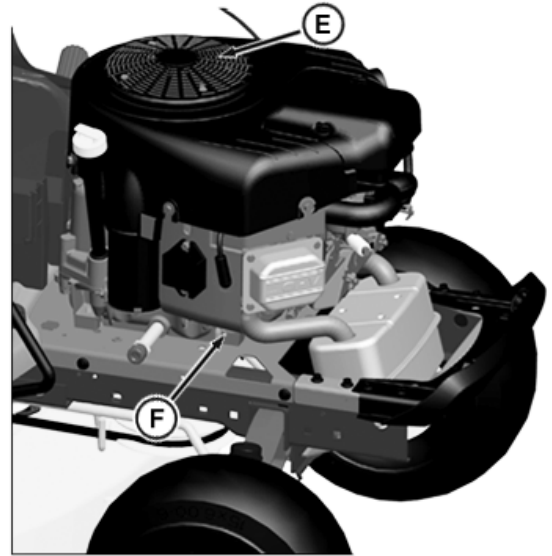

PY19179—UN—23JAN14

2. Engine intake screens (E), cooling fins (F), and oil cooler (if equipped).



GXAL41971—UN—04MAR13

3. Top of mower deck, under shields (G), including spindle (H) and belt areas.

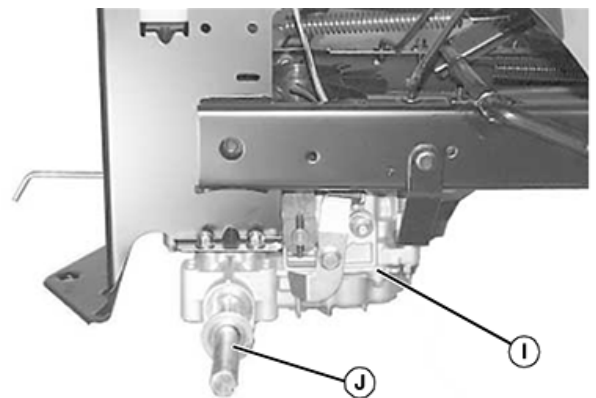

GXAL41972—UN—04MAR13

Shown with wheel removed

Assembly

4. On or near transmission (I) and driveline (J).



5. Under left side panel near fuse block (K), and all wiring, including the battery (L) and related wiring harnesses (M).

Assembly

Charge and Connect Battery

CAUTION: The battery produces a flammable and explosive gas. The battery may explode:

- Do not smoke or have open flame near battery.
 - Wear eye protection and gloves.
 - Never check battery charge by placing a metal object across the posts. Use a voltmeter or hydrometer.
 - Do not jump start or charge a frozen battery. Warm battery to 16°C (60°F).
1. Remove and discard the tie strap from the positive (+) battery terminal.
 2. Remove and discard the black protective cap from the negative (-) battery terminal.
 3. Charge the battery.

Specification

Battery Full Charge — Voltage 12.6 volts

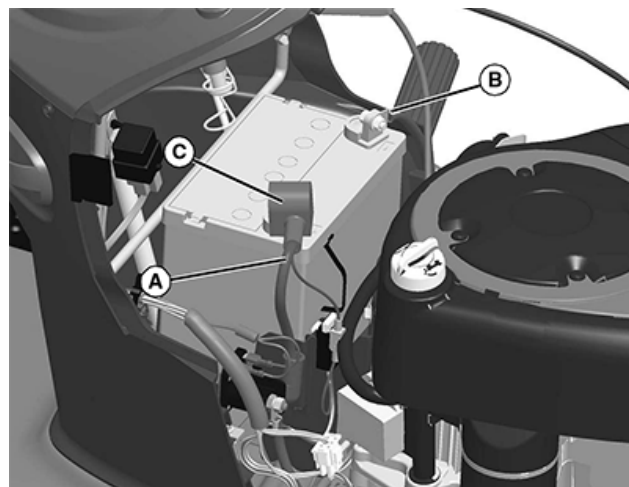

4. Connect positive (+) battery cable (A) to battery.
5. Connect negative (-) battery cable (B).
6. Apply general purpose grease or silicone spray to terminal to help prevent corrosion.
7. Slide red cover (C) over positive battery cable.

Check Tire Pressure

Check tire pressure. (See Checking Tire Pressure in the SERVICE MISCELLANEOUS section.)

Adjust Mower Deck Level

Adjust mower deck level. (See Adjusting Mower Deck Level in the OPERATING section.)

Check Engine Oil Level

Check engine oil level. (See Checking Engine Oil Level in the SERVICE ENGINE section.)

Check Machine Safety System

Perform safety system check to make sure the electronic safety interlock circuit is functioning properly. Perform all tests. (See Testing Safety System in the OPERATING section.)

Break In Electric Engagement Clutch (If Equipped)

1. Start engine and move machine to flat level surface.

Assembly

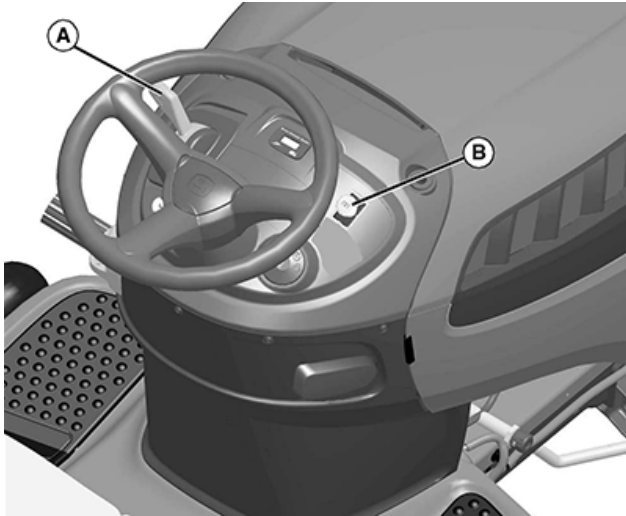

GXAL41975—UN—04MAR13

2. Push throttle lever (A) up to full throttle position.
3. Engage attachment engagement switch (B) and allow mower to run for 10 seconds.
4. Disengage attachment engagement switch and wait 10 seconds.
5. Repeat steps 3 and 4 for 12-15 cycles.

NOTE: Clutch is now properly burnished.

Operating Controls

Operating Controls

Operator Station Controls (D105)



PY19028—UN—07AUG13

A — Brake pedal
B — Park Brake Lock Lever
C — Throttle/Choke Lever
D — Reverse Implement Option (RIO) Switch
E — Service Reminder/Hourmeter
F — Key Switch

G — Attachment Engagement Lever
H — Motion Pedal
I — Deflector Shield
J — Transmission Shift Lever
K — Fuel Level Window
L — Attachment Lift Lever

Operating Controls

Operator Station Controls (D110, D125, D130)

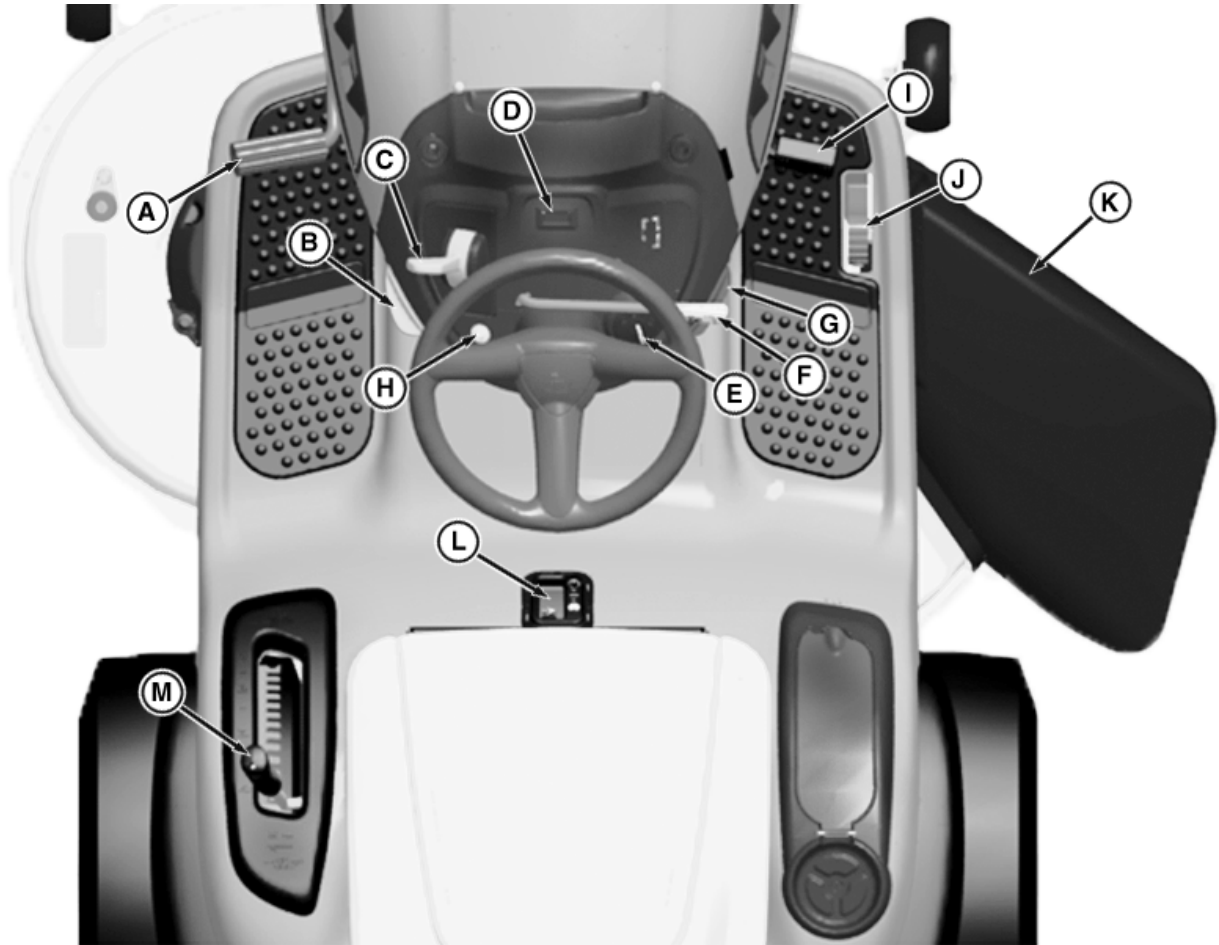

PY19030—UN—07AUG13

A — Brake Pedal
B — Park Brake Lock Lever
C — Throttle/Choke Lever
D — Service Reminder/Hourmeter
E — Key Switch
F — Attachment Engagement Lever
G — Cruise Control Lever (D125 and D130)

H — Reverse Implement Option (RIO) Switch
I — Forward Travel Pedal
J — Reverse Travel Pedal
K — Deflector Shield
L — Fuel Level Window
M — Attachment Lift Lever

Operating

Operator Station Controls (D140, D155, D160, D170)



PY19049—UN—07AUG13

- A — Brake Pedal
- B — Park Brake Lock Lever
- C — Throttle/Choke Lever
- D — Reverse Implement Option (RIO) Switch
- E — Service Reminder/Hourmeter
- F — Key Switch
- G — Cruise Control Lever

- H — Attachment Engagement Switch
- I — Forward Travel Pedal
- J — Reverse Travel Pedal
- K — Deflector Shield
- L — Fuel Level Window
- M — Attachment Lift Lever

Operating

Daily Operating Checklist

- Test safety systems.
- Check tire pressure.

IMPORTANT: Using stale, contaminated or improper fuel can result in engine and fuel system damage. Repairs caused by stale, contaminated or improper fuel are not covered by warranty.

- Check fuel level. (See SERVICE MISCELLANEOUS section, Using Proper Fuel and Stabilizer)
- Check engine oil level.
- Remove grass and debris from engine compartment and muffler area, and on top of mower deck, before and after operating machine.
- Clean air intake screen.
- Check area below machine for leaks.

Avoid Damage to Plastic and Painted Surfaces

- Do not wipe plastic parts unless rinsed first. Using a dry cloth may cause scratches.
- Insect repellent spray may damage plastic and painted surfaces. Do not spray insect repellent near machine.
- Be careful not to spill fuel on machine. Fuel may damage surface. Wipe up spilled fuel immediately.
- Prolonged exposure to sunlight will damage some surfaces.

Adjusting Seat

1. Sit in seat.

Operating



GXAL41979—UN—04MAR13

2. Lift up on (A) on right side of seat.
3. Lean forward and slide seat forward or rearward to desired position. Do not lean back on top of seat to push rearward.
4. Release seat adjustment lever to lock in position.

Lumbar Seat Adjustment (D160, D170)

- Turn lumbar seat adjustment dials (B) on either side of seat to adjust firmness of seat.

Adjusting Cutting Height

Cutting height is adjusted from approximately 25—100 mm (1—4 in.) in 6.4 mm (1/4 in.) increments. When mower deck is in transport position, cutting height is approximately 100 mm (4 in.).

Detents allow the adjustment lever to be positioned at each indicated mower setting, as well as the mid-point between each setting.

Mower Setting	Approximate Cutting Height
1	25 mm (1 in.)
–	32 mm (1-1/4 in.)
–	38 mm (1-1/2 in.)
2	50 mm (2 in.)
–	57 mm (2-1/4 in.)
–	65 mm (2-1/2 in.)
–	70 mm (2-3/4 in.)
3	75 mm (3 in.)
–	83 mm (3-1/4 in.)
–	90 mm (3-1/2 in.)
–	95 mm (3-3/4 in.)
4 (Transport)	100 mm (4 in.)

1. Put attachment lift lever into the slot near desired cutting height.
2. Adjust mower deck wheels.

Transporting or Getting On and Off Machine

- Pull attachment lift lever all the way back to transport position or 100 mm (4 in.) cutting height.

Checking and Adjusting Mower Deck Level

CAUTION: Rotating blades are dangerous. Before adjusting or servicing mower:

- Disconnect spark plug wire(s) or battery negative (-) cable to prevent engine from starting accidentally.
- Always wear gloves when handling mower blades or working near blades.

NOTE: Mower deck wheels should not contact the ground when leveling the mower deck.

Method One

1. Make sure machine is on a flat, level surface.
2. Park machine safely. (See Parking Safely in the SAFETY section.)
3. Check that tires are inflated to correct tire pressure. Tire pressure is marked on the side of the tire.
4. Raise deck to highest position.

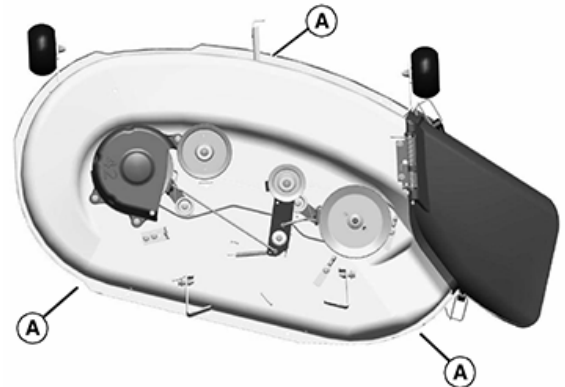

GXAL41980—UN—04MAR13

107 cm (42 in.) mower deck shown

5. Place three short 51 mm (2 in.) blocks of wood under the edges (A) of the mower deck.
6. Lower mower deck to the 63 mm (2.5 in.) cutting height position. For D130 models, lower deck to 57 mm (2-1/4 in.) cutting height position.
7. Check that the mower deck is level and lightly touching each of the three wooden blocks.

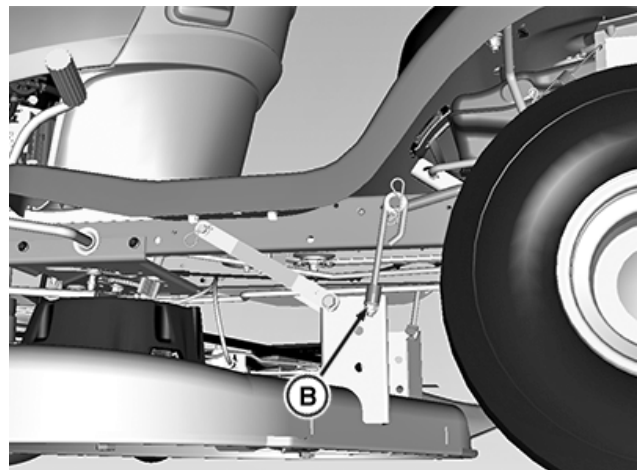

PY21324—UN—19AUG14

Operating

- If the rear of the mower deck is not touching the rear blocks, or is sitting heavily on the blocks, adjust the rear lift links by turning the leveling nut (B) on each lift link. The blocks should be able to easily slide in and out beneath the mower deck when the mower deck is correctly adjusted.

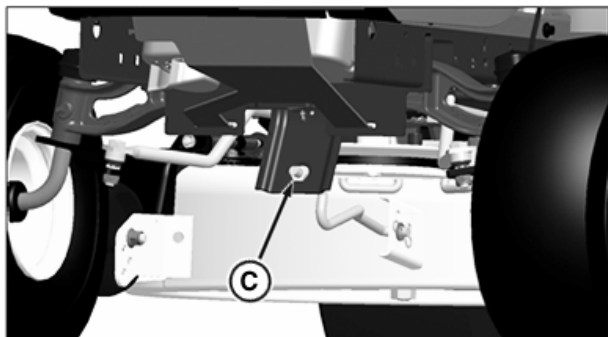

PY19180—UN—23JAN14

107 cm (42 in.) mower deck shown

- If the front of the mower deck is not lightly touching the front block, adjust the front draft arm by turning the nut (C).
8. Raise the cutting height to the next highest position and remove the three wooden blocks.
 9. Turn the nut (C) on the front draft arm counterclockwise 1-2 full turns so that the front of the deck is 3-6 mm (1/8-1/4 in.) lower than the rear. This adjustment prevents "double cutting," which wastes horsepower and causes brown grass tips.

Specification

Mower Deck, Front-to-Back — Height 1/8-1/4 in. (3-6 mm)

Method Two

NOTE: An optional mower deck leveling gauge (AM130907) is available from your John Deere dealer. It allows for precision mower deck leveling by measuring mower deck level at the blade tips.

1. Make sure machine is on a flat, level surface.
2. Park machine safely. (See Parking Safely in the SAFETY section.)
3. Inflate tires to the correct pressure.
4. Move mower lift handle to preferred cutting height.
5. Measure mower deck level (side-to-side).

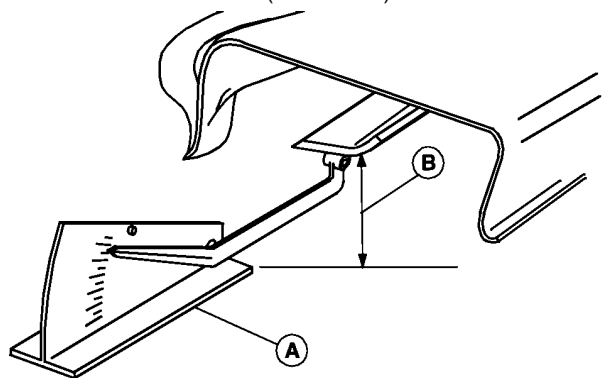

GXAL41983—UN—04MAR13

A convenient leveling gauge (A) (AM130907) is available from your dealer.

- a. Position mower blades as follows and measure from each outside blade tip (B) to the level surface.

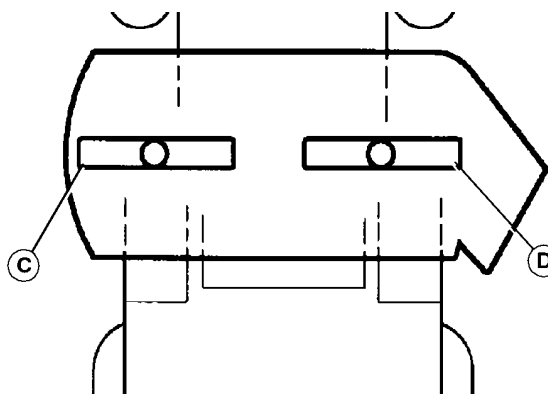

GXAL41984—UN—04MAR13

- b. Turn left blade (C) as shown. Hold drive belt and turn right blade (D) as shown. Take measurement for both blades. The difference between blade measurements must not be more than specified distance.

Specification

Mower Deck Blade Outside Tips to Ground (Difference)

— Distance 1/8 in. (3 mm)

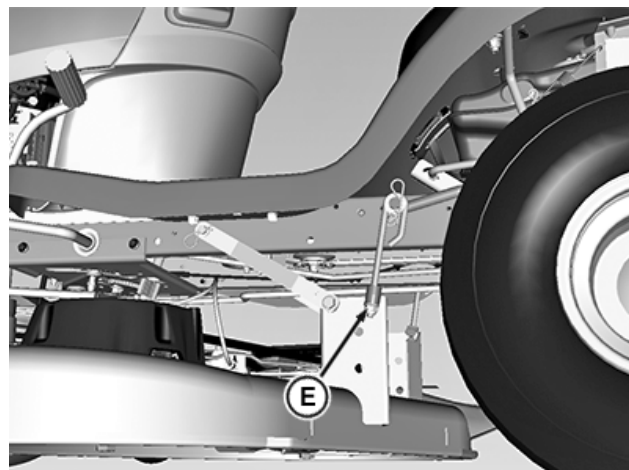

PY21325—UN—19AUG14

- c. Adjust mower deck level, if necessary, by turning rear nuts (E) clockwise to raise the side of the mower deck, or counterclockwise to lower the mower deck.

6. Measure mower level (front-to-rear).

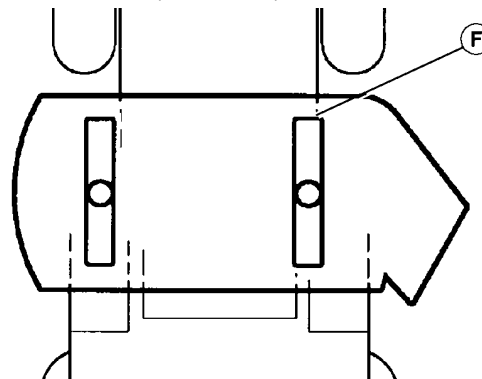

GXAL41986—UN—04MAR13

- a. Turn right blade (F) so blade tip points straight forward.

Operating

- b. Measure from blade tip to the surface. Take measurement for both blades.
The front blade tip must be specified distance lower than rear blade tip.

Specification

Mower Deck Blade Outside Tips to Ground (Difference)
— Distance 3–6 mm (1/8 -1/4 in.)

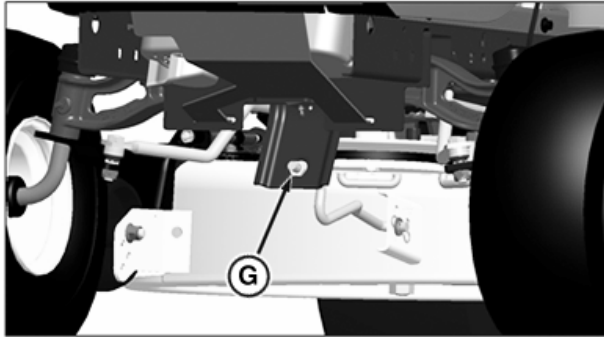

PY19193—UN—27JAN14

107 cm (42 in.) mower deck shown

- c. Adjust mower deck level, if necessary, by turning the nut (G) counterclockwise to lower the front of deck or clockwise to raise front of deck.

Adjusting Mower Deck Wheels

IMPORTANT: The mower deck can be damaged if mower wheels are adjusted wrong:

- Bottom of wheels should be approximately 3 to 13 mm (1/8 to 1/2 in.) from the ground.
- If mowing at 75 mm (3 in.) height of cut or higher set the anti-scalp wheels in their lowest position

1. Park machine safely. (See Parking Safely in the SAFETY section.)
2. Inflate tires to the correct pressure.
3. Lower mower deck to the desired mowing position.

NOTE: Bottom of wheels should be approximately 3-13 mm (1/8-1/2 in.) from the ground.

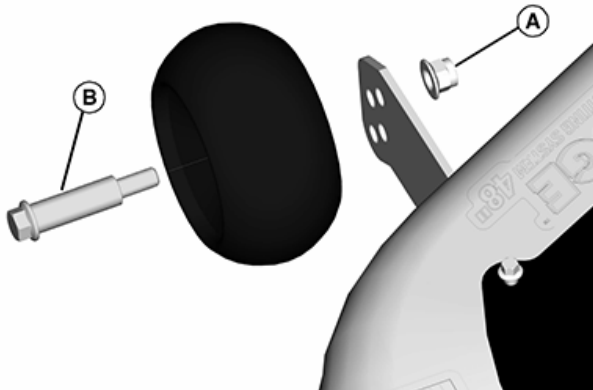

GXAL41988—UN—04MAR13

4. Check each mower wheel position. Remove nut (A) and bolt (B), and move mower wheel to proper hole.

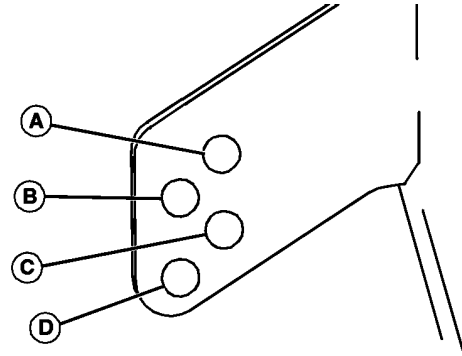

GXAL41989—UN—04MAR13

- A — 38 mm (1.5-in.) or less
- B — 51 mm (2-in.)
- C — 64 mm (2.5-in.)
- D — 76 mm (3-in.) and above

5. Install bolts and nuts to lock wheels in position. Tighten nuts to specifications.

Specification

Mower Deck Wheel Nut — Torque 25 lb-ft (34 N·m)

Testing Safety Systems

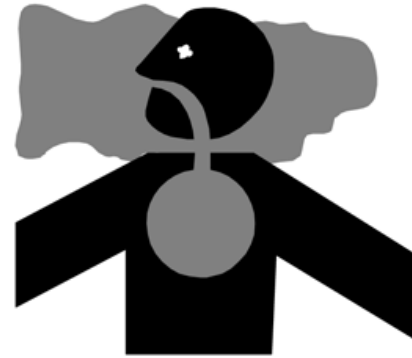

MXAL42804—UN—09APR13

CAUTION: Engine exhaust fumes contain carbon monoxide and can cause serious illness or death.

Do not run an engine in an enclosed area, such as a garage, even with doors or windows opened.

Move the machine to an outside area before running the engine.

The safety systems installed on your machine should be checked before each machine use. Be sure you have read the machine operator manual and are completely familiar with the operation of the machine before performing these safety system checks.

Use the following checkout procedures to check for normal operation of machine.

If there is a malfunction during one of these procedures, do not operate machine. **See your authorized dealer for service.**

Perform these tests in a clear open area. Keep bystanders away.

Testing Park Brake Switch

1. Park machine safely. (See Parking Safely in the SAFETY section.)
2. Sit on seat.
3. Unlock the park brake.

Operating

4. Try to start engine.

Result: Engine must not crank. If engine cranks, there is a problem with your safety interlock circuit.

Testing Park Brake

1. Park machine safely. (See Parking Safely in the SAFETY section.)
2. Lock the park brake.
3. Engage bypass valve control.
4. Try to push machine manually.

Result: Park brake must prevent machine from moving. If machine moves, parking brake needs to be adjusted.

Testing Attachment Engagement Switch or Lever

CAUTION: The mower blades should stop in approximately five seconds when the mower or PTO is disengaged.

If you believe that your blades may not be stopping in that period of time, take your machine to your authorized dealer where they can safely check and service your machine.

1. Park machine safely. (See Parking Safely in the SAFETY Section.)
2. Sit on seat.
3. Lock the park brake.
4. Engage mower:
 - On models with electric attachment engagement switch, pull switch up.
 - On models with mechanical attachment engagement lever, push lever forward.
5. Try to start engine.

Result: Engine must not start. If engine starts, there is a problem with your safety interlock circuit.

Testing Seat Switch

1. Park machine safely. (See Parking Safely in the SAFETY Section.)
2. First test:
 - a. Lock park brake.
 - b. Start engine.
 - c. Move throttle lever up to maximum engine speed.
 - d. Engage mower.
 - e. Raise up off seat. Do not get off machine.

Result: Engine and mower blades should stop. If engine and mower blades do not stop, there is a problem with your safety interlock circuit.

3. Second test:
 - a. Disengage mower.
 - b. Start engine.
 - c. Unlock park brake.
 - d. Raise up off seat. Do not get off machine.

Result: Engine should stop. If engine does not stop, there is a problem with your safety interlock circuit.

4. Third test:
 - a. Lock park brake.
 - b. Disengage mower.
 - c. Start engine.
 - d. Raise up off seat. Do not get off machine.

Result: Engine should continue to run. If engine stops, there is a problem with your safety interlock circuit.

Testing Reverse Implement Option (RIO)

1. Park machine safely. (See Parking Safely in the SAFETY section.)
2. Start engine.
3. Engage attachment engagement switch or lever to start attachment.

CAUTION: Rotating blades are dangerous. Children or bystanders may be injured by runover and rotating blades. Before backing up, carefully check the area around the machine.

4. Look behind the vehicle to be sure there are no bystanders.
5. Begin reverse travel by depressing reverse pedal for hydrostatic transmission or moving the transmission shift lever to the rear slot (reverse) position for automatic transmission and depressing pedal.

Result: Attachment and engine should stop operation. If attachment or engine continues to operate as machine begins travel in reverse, do not continue to operate machine.

Using the Park Brake

CAUTION: Children or bystanders may attempt to move or operate an unattended machine.

Always lock the park brake and remove the key before leaving the machine unattended.

Locking park brake:

1. Push and hold brake pedal down.
2. Pull park brake lever up to lock park brake.
3. Release brake pedal. Pedal should stay down and park brake lever should stay locked.

Unlocking park brake:

1. Push and hold brake pedal down.
2. Push park brake lever down to unlock park brake.
3. Release brake pedal.

Using the Hourmeter and Service Reminder



PY21336—UN—28AUG14

Operating

- The hourmeter (A) shows the number of hours the engine has run. The service reminder will indicate that a general lubrication (B) or mower/engine (C) service interval has been reached. When service is required, the service "SVC" arrows (D) will periodically flash for two hours. Follow the service timetable on the maintenance schedule located under the seat. For specific service procedures, see the Service section of this manual.
- Hourmeter cannot be reset.
- The hourmeter display will always be on.
- The decimal point will flash while the hourmeter is accumulating time.

Using Key Switch and Headlights

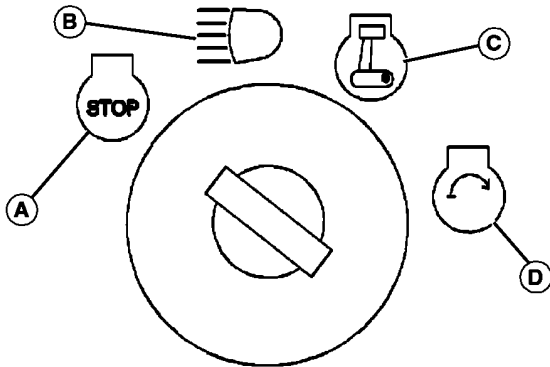

- A — STOP Position
- B — Headlights On Position
- C — Run Position
- D — Start Position

Engine Off

NOTE: Headlights will drain the battery rapidly if key switch is left in headlights on position (B) with the engine off.

- To turn headlights on, turn key switch to headlights on position (B).
- To turn headlights off, turn key switch to STOP position (A).

Engine On

- To turn headlights on, start engine, then turn key switch from run position (C) to headlights on position (B).
- To turn headlights off, turn key switch from headlights on position (B) to run position (C).

Starting the Engine

IMPORTANT: Hydrostatic transmission might be damaged if the bypass rod is not pushed back to operating position before attempting to start the engine. Do not start or operate the machine with the bypass rod in the pulled-out position.

1. Make sure bypass rod is pushed in.

CAUTION: Engine exhaust fumes contain carbon monoxide and can cause serious illness or death.

Do not run an engine in an enclosed area, such as a garage, even with doors or windows opened.

Move the machine to an outside area before running the engine.

2. Sit in seat.
3. Make sure mower is disengaged. (See Engaging and Disengaging Mower in the OPERATING section.)

4. Lock the park brake.
5. For automatic models, put transmission shifter into center slot.

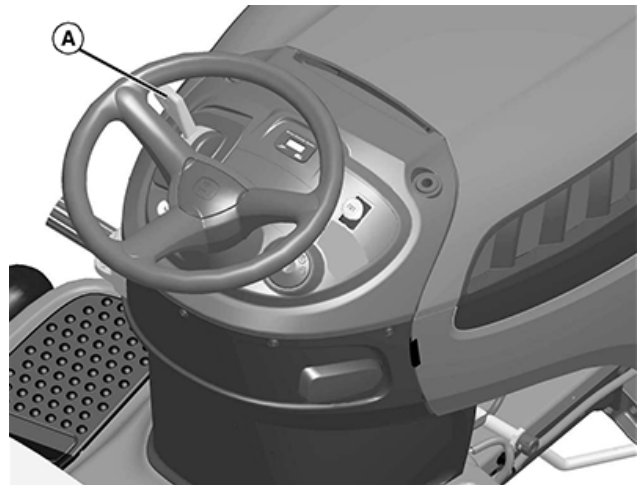

6. Check starting conditions:
 - If engine is cold: Move throttle/choke lever (A) up to the choke position.
 - If engine is warm: Move throttle/choke lever (A) to the half-speed position.

IMPORTANT: Starter may be damaged if starter is operated for more than 20 seconds at a time:

Wait two minutes before trying again if engine does not start.

7. Turn key to start position for no more than five seconds.
8. Release key to run position when engine starts, and gradually move choke lever down to the off position.
 - If engine does not start, wait 10 seconds.
 - Turn key to start position again for no longer than 5 seconds.
 - Repeat procedure if necessary.

IMPORTANT: Unnecessary engine idling may cause engine damage. Excessive idling can cause engine overheating, carbon build-up, and poor performance.

9. Let engine run at high idle for a couple of minutes to warm-up before operating machine.

Idling the Engine

IMPORTANT: Unnecessary engine idling may cause engine or transmission damage. Excessive idling can cause engine overheating, carbon build-up, and poor performance.

Idling or low throttle operation while mowing, climbing hills, or towing could result in transmission overheating. always operate at full throttle once the engine is warm.

Do not operate machine with hood open. Hood must be closed for proper engine cooling and exhaust.

- Engine is air cooled and needs a large volume of air to keep cool. Keep air intake screen on top of engine clean.
- Keep hood closed when engine is idling.

Operating

Stopping the Engine

IMPORTANT: Do not stop the engine by moving choke control to the choke position. Backfire, fire or engine damage can occur. Follow recommended procedure for stopping engine.

1. Let engine run at high throttle without load for a few seconds.
2. Turn key to STOP position. Engine will stop and headlights will turn off.
3. Remove key.
4. Lock the park brake.

Using Travel Controls on Automatic Transmission

CAUTION: Children or bystanders may be injured by runover and rotating blades. Before traveling forward or rearward:

- Carefully check the area around the machine.
- Disengage the mower before backing up.

IMPORTANT: Stop machine movement before shifting between reverse and forward to prevent transmission damage.

Travel Forward



PY19050—UN—07AUG13

1. Completely remove foot from travel pedal (A).
2. Push brake pedal (B) all the way down to stop machine.
3. Move transmission shift lever into forward slot (C).
4. Release brake pedal.
5. Slowly apply foot to travel pedal.

Travel in Reverse

1. Completely remove foot from travel pedal (A).

NOTE: Any operating attachment and the engine will stop as the transmission shift lever is moved to rear slot (D) (reverse) with attachment engaged.

2. It may be required to push brake pedal to stop machine when on a slope.
3. Move transmission shift lever to rear slot (D).
4. Look behind the machine to be sure there are no bystanders nearby.
5. Release brake pedal.
6. Slowly apply foot to travel pedal.

Emergency Stopping

Push brake pedal all the way down to stop machine.

Using Travel Controls on Hydrostatic Transmission

CAUTION: Children or bystanders may be injured by runover and rotating blades. Before traveling forward or rearward:

- Carefully check the area around the machine.
- Disengage the mower before backing up.

Travel Forward

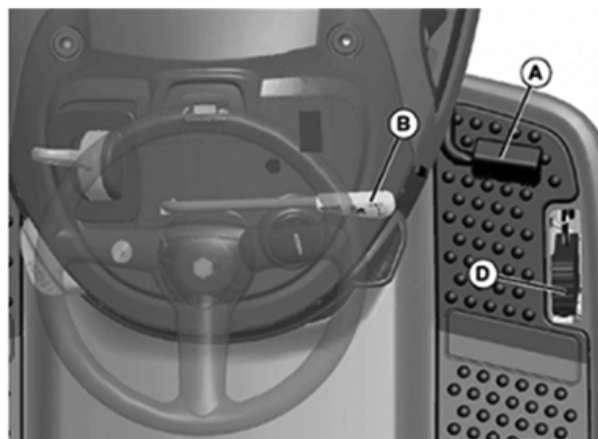

PY21328—UN—19AUG14

Tractor with PTO lever

- Push down the forward travel pedal (A).

Travel in Reverse

NOTE: Any operating attachment and the engine will stop as the reverse motion pedal is pressed with attachment engaged.

Operating

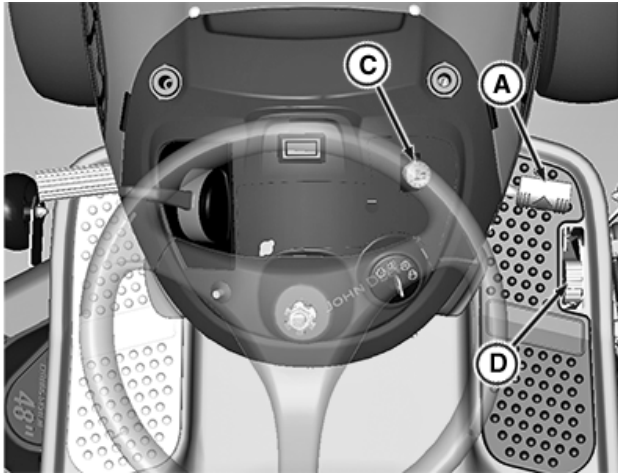

PY21330—UN—19AUG14

Tractor with PTO switch

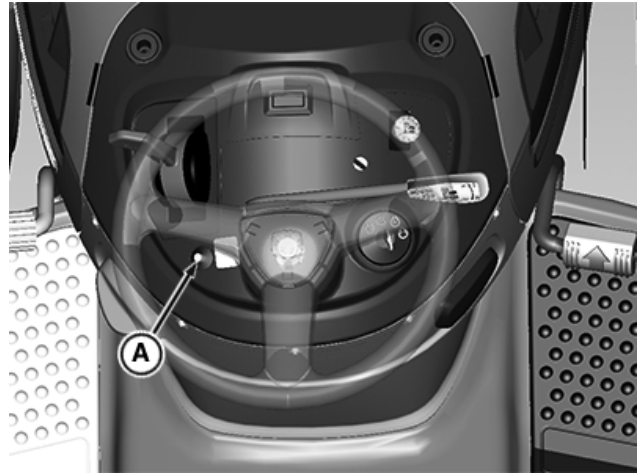

PY21327—UN—19AUG14

1. Disengage attachment:
 - On models with mechanical attachment engagement lever (B), pull lever back to the off position.
 - On models with electric attachment engagement switch, push switch in location (C) (not shown above) down to the off position.
2. Look behind the machine to be sure there are no bystanders nearby.
3. Touch the reverse travel pedal (D) with front of foot and slide foot over pedal from front to rear.

Emergency Stopping

- Push brake pedal all the way down to stop machine.

Using The Reverse Implement Option (RIO)

! CAUTION: Children or bystanders may be injured by runover and rotating blades. Before traveling forward or rearward:

- Carefully check the area around the machine.
- Disengage the mower before backing up.

NOTE: Backing up while the mower is engaged is strongly discouraged. The Reverse Implement Option should be used only when operating another attachment or when the operator deems it necessary to reposition the machine with the mower engaged.

1. Stop forward travel.
2. Look behind the machine to be sure there are no bystanders.

3. Push and hold in the reverse implement switch (A) while depressing reverse pedal slightly for hydrostatic transmission or moving the transmission shift lever to the rear slot (reverse) for automatic transmission.

NOTE: If the engine and mower stop while repositioning the machine, return the attachment engagement lever/switch to the off position. Start engine and engage mower. Begin again with Step 2.

4. Release the reverse implement switch and reposition the machine as the machine begins to move rearward.
5. Resume forward travel. The mower should continue operating.
6. Repeat procedure to position the machine again.

Using Cruise Control (D125, D130, D140, D155, D160, D170)

! CAUTION: Do not use cruise control when going down hills. Machine speed will increase. Operate machine in a large, open area to learn how the cruise control works.

Use cruise control when you want to maintain travel speed without having to hold the forward travel pedal down. Cruise control operates only for forward travel.

Engage Cruise Control

1. Push forward pedal down until you reach desired travel speed.
2. Pull cruise control lever up and release forward pedal to lock the cruise control.

Disengage Cruise Control

- Depress brake pedal, tap on forward pedal or push cruise control lever down to the off position.

Engaging and Disengaging Mower

NOTE: Put attachment lift lever in transport position to transport machine or when parking machine.

1. Start engine and run at half speed for a couple of minutes to warm up.
2. Lower mower deck to desired cutting height position.

NOTE: Throttle lever should be at full throttle position before engaging mower to avoid stalling engine.

Operating

3. Push throttle lever up to the full throttle position.
4. Engage mower.
 - On models with electric attachment engagement switch: Pull switch up.
 - On models with mechanical attachment engagement lever: Push lever forward.

NOTE: The mower and engine will stop as the reverse foot pedal is pressed for hydrostatic transmission or when the transmission shift lever is moved to the rear slot (reverse) position for automatic transmission with mower engaged.

5. Disengage mower blades before moving in reverse or stopping engine.
 - Machines with mechanical attachment engagement lever: Pull lever back.
 - Machines with electric attachment engagement switch: Push switch down.

Using Wash Port to Clean Mower Deck

NOTE: Follow this procedure after each use to prevent buildup and remove corrosive lawn chemicals.

1. Park machine safely. (See Parking Safely in the Safety section).



GXAL41997—UN—04MAR13

2. Attach quick-coupler to garden hose.
3. Attach garden hose with quick-coupler to wash port (A) on the mower deck.
4. Turn on water.
5. Start engine.
6. Run at full throttle.
7. Engage mower blades.
8. Flush water under deck for approximately one minute.
9. Disengage mower blades.
10. Stop engine.
11. Turn off water and remove garden hose and quick-coupler from wash port.
12. Remove quick-coupler from garden hose and store for future use.

Unplugging Mower, Bagger, or Material Collection System

CAUTION: Do not attempt to unplug attachment with machine running.

- Rotating blades are dangerous. Shut off the engine and remove the key before getting off the seat to inspect the machine and attachment.
- Thrown objects can cause serious injury. Make sure all machine parts are stopped before raising hopper top or removing chutes.

Checking For Plugging While Driving

If grass builds up in front of mower discharge chute, check for plugged chute or problems with blower assembly (if equipped).

If there is a trail of clippings behind mower or clippings blow to the side, check for plugged chute, full collector bags, or problems with blower assembly.

Removing Debris From Inspection Points:

CAUTION: Do not use hands or feet to clear plugged mower deck or blower assembly. Stored energy can cause blades to rotate.

1. Park machine safely. Wait for all moving parts to stop before getting off to inspect machine.
2. Open hopper cover. Check chute outlet.
3. Remove chute from mower deck or blower assembly. Check chute inlet.
4. Check under mower deck for debris.

Moving Machine by Hand

CAUTION: When the bypass valve is open, the machine will have unrestricted motion.

- Do not open the bypass valve when the machine is stopped on an incline to prevent it from going downhill out of control.

IMPORTANT: Transmission damage may occur if the machine is towed or moved incorrectly:

- Move machine by hand only.
- Do not use another vehicle to move machine.
- Do not tow machine.

1. Unlock the park brake.
2. Put automatic transmission shifter into center position.

Operating

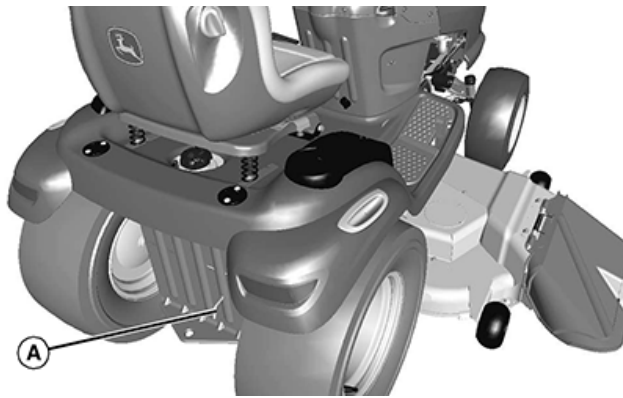

GXAL41998—UN—04MAR13

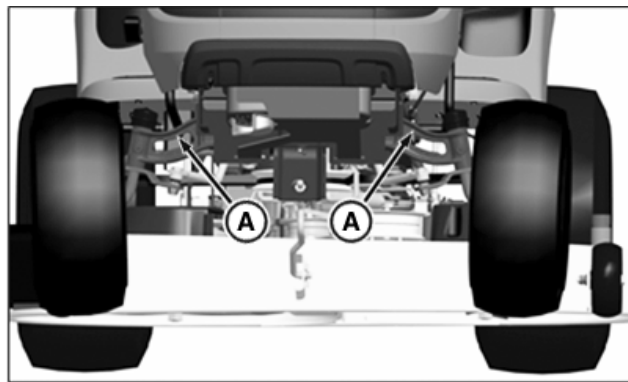

PY19181—UN—23JAN14

3. On automatic and hydrostatic Models: Pull out on bypass rod (A).
4. Push machine to desired location.

IMPORTANT: Hydrostatic transmission might be damaged if the bypass rod is not pushed back to operating position before attempting to start the engine. Do not start or operate the machine with the bypass rod in the pulled-out position.

5. Push bypass rod back in.
6. Lock the park brake.

7. Secure front of machine at both sides of the axle at points (A) to trailer with heavy-duty straps, chains, or cables. Straps must be directed down and outward from machine.

IMPORTANT: Do not secure machine using transmission housing.

Transporting Machine on Trailer

NOTE: Trailer capacity must exceed combined machine weight and attachment weight. (See Specifications section in operator's manual.)

Be sure the trailer has all necessary lights and signs required by law.

CAUTION: Use extra care when loading or unloading the machine onto a trailer or truck.

- Park trailer on a level surface.
- Use of a trailer with sides is recommended.
- Keep wheels away from drop-offs and edges.
- Back slowly and in a straight line.
- Close fuel shut-off valve, if your machine is equipped.
- Do not secure machine using optional bumper as this can dislodge during transport.

IMPORTANT: Transporting a machine on a trailer or on a truck bed at high speeds can result in hood or engine cover raising and possibly coming off machine if not secured.

- Position machine on trailer so hood or engine cover opens from rear of trailer to prevent wind from blowing hood or cover open.
 - Secure hood or engine cover with existing machine locks or latches.
 - Secure hood or engine cover with tie down straps if no locks or latches exist.
1. Park trailer on a level surface.
 2. Raise mower deck, if installed, before driving machine onto trailer.
 3. Drive machine onto heavy-duty trailer. Position machine on trailer so hood or engine cover will not raise in wind while being transported.
 4. Lower mower deck completely.
 5. Lock park brake.
 6. Turn off machine and remove key.

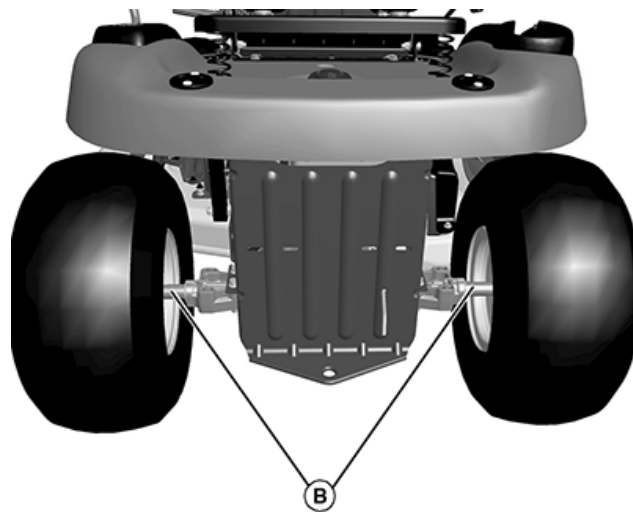

GXAL42000—UN—04MAR13

8. For hydrostatic transmissions, secure rear of machine at both sides of the axle at points (B) to trailer with heavy-duty straps, chains, or cables. Straps must be directed down and outward from machine.

Operating

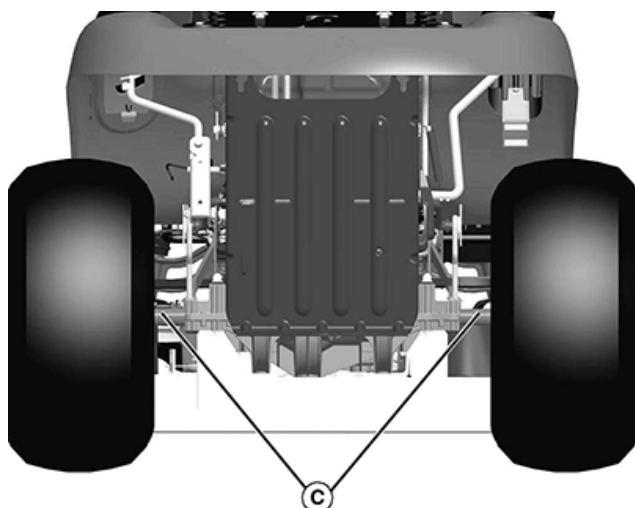

GXAL42001—UN—04MAR13

D105 shown

9. For automatic transmission machines, secure rear of machine at both sides of the axle at points (C) to trailer with heavy-duty straps, chains, or cables. Straps must be directed down and outward from machine.
10. Secure hood to prevent from lifting while driving.

Using Weights

- CAUTION:** The machine may become unstable when operating on slopes and/or with some attachments.
Use weights to improve stability when operating on slopes or using attachments.
Remove weights when not required.

IMPORTANT: Never use liquid in tires or wheel weights as ballast. Transmission damage can occur.

When rear ballast is needed, use only the approved rear weight bracket and attaching weights.

NOTE: See your authorized dealer for recommended weights.

- Install front weights for added stability and steering control when you use equipment such as the rear-mounted grass bagger.
- Install rear weights when using the snow blade or snowblower.
- Remove weights when not required.

Using Tire Chains

IMPORTANT: Do not use chains with mower deck or tiller.

Tire chains are recommended for use with most front attachments. Remove tire chains before installing mower deck.

See your attachment Operator's Manual for tire chain recommendation. See your authorized dealer for the chains.

Using Accessories

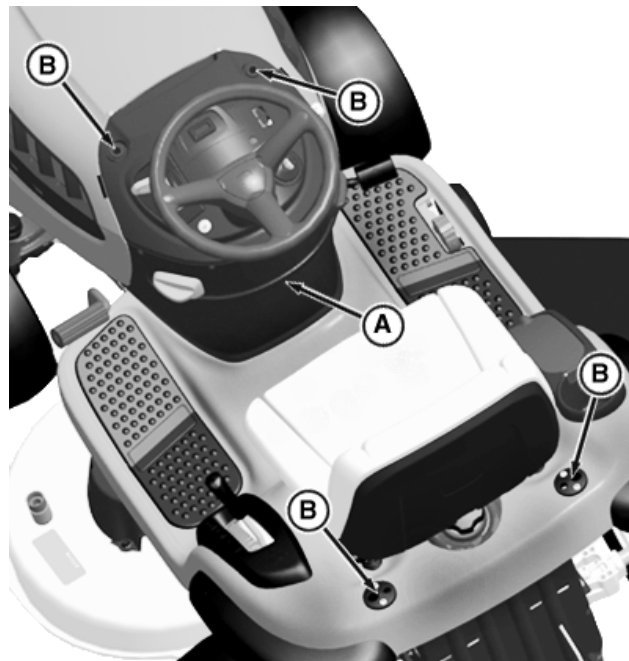

PY19031—UN—07AUG13

Using the Power Port (If Equipped)

- CAUTION:** Safe operation requires your full attention. Do not wear radio or music headphones while operating machine.

An electric power port (A) can be used for accessories. See your authorized dealer.

Using CargO Mount System™

The front and rear CargO Mount System™ brackets (B) can be used for easy attachment of selected optional equipment.

Use John Deere approved optional equipment only. See your Authorized Service Center for approved optional equipment.

Choosing Mower Blades

Three types of mower blades are available for use with D series mowers.

- 3-N-1 blades. These are general purpose blades that are best suited for side-discharge operation, but can be used with a bagger attachment, or with a mulch cover installed. They are not designed for optimal performance when bagging or mulching.
- Bagger blades. These blades are designed for optimal performance when used with bagger attachments.
- Mulching blades. These blades are designed for optimal performance when used with a mulch cover installed.

Mowing Tips

The following recommendations will produce the best lawn cut quality and appearance:

- Keep mower blades sharp. Dull blades will tear grass; tips of grass will then turn brown.
- Cutting grass too short may kill grass and let weeds grow easily. The suggested finished cut height should be within specified height range.

Specification

Finished Cut Height Range — Height 1.75 - 2.75 in. (44 - 70 mm)

Service Intervals

- Adjust cutting height to remove only 1/3 of the grass at a time.
- Do not mow wet grass.
- Mow grass often. Short grass clippings will decay quickly.
- Mow with engine at full throttle.
- Adjust travel speed to match mowing conditions:
 - Travel at slow speed when you mow thick, tall grass, make sharp turns or trim around objects.
 - Travel at moderate speed when you mow thin grass.
- Use a different mowing pattern each time you mow. Overlap mowing paths by specified distance.

Specification

Overlap Mowing Paths — Distance: 50 - 100 mm (2 - 4 in.)

- Drive over ridges and through shallow ditches straight-on, not at an angle.

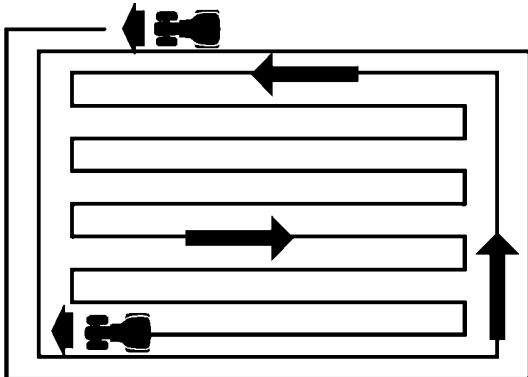

GXAL42003—UN—04MAR13

- Mow around the outside twice, then mow inside in straight passes. Best cut is achieved when mowing in a straight line.
- When mowing or mulching near pavement, overlap the pavement by 50 mm (2 in.) to allow clippings to dispense over grass.
- A thick layer of mulched leaves can prevent sunlight from getting to grass and smother it. Taller grass heights allow mulched leaves to dispense easier in lawn. Mulch leaves several times if needed.
- Use a thatcher in late spring or summer to pull up dead grass and aerate ground.
- For Mulching Mower: Shorter cut heights will provide better cut quality, but may leave noticeable clippings. Higher cut heights will reduce clippings, but cut quality may decline.

Service Intervals

Servicing Your Machine

IMPORTANT: Operating in extreme conditions may require more frequent service intervals:

- Engine components may become dirty or plugged when operating in extreme heat, dust or other severe conditions.
- Engine oil can degrade if machine is operated constantly at slow or low engine speeds or for frequent short periods of time.

Please use the following timetables to perform routine maintenance on your machine.

Park the vehicle safely. See Park Safely in the SAFETY Section.

Service Intervals

Initial Service 8 Hours

- Change engine oil and filter.
- Lubricate mower spindles and pivot points.
- Check/Adjust mower deck belt tension (Manual PTO).
- Check/Adjust mower deck spindle brakes (Manual PTO).
- Lubricate front axle pivot and axle spindles.
- Lubricate front axle wheel bushings.

Every 25 Hours

- Lubricate mower spindles and pivot points.
- Lubricate front axle pivot and axle spindles.
- Lubricate front axle wheel bushings.

Yearly or Every 50 Hours

- Change engine oil and filter. (Service more frequently under dusty conditions.)
- Replace air filter element. (Service more frequently under dusty conditions.)
- Replace fuel filter.
- Replace spark plug(s).
- Clean engine cooling fins.
- Clean/Replace emission filter (If equipped).
- Sharpen/replace mower blades.
- Check/replace mower drive belts.
- Check/level mower deck.
- Clean mower deck.
- Check/Adjust mower deck belt tension (Manual PTO).
- Check/Adjust mower deck spindle brakes (Manual PTO).
- Clean battery terminals.

Every 200 Hours

- Check/adjust valve clearance. See your John Deere dealer for this service.

Service Lubrication

Grease

IMPORTANT: Avoid Damage! Use recommended John Deere greases to avoid component failure and premature wear.

The following grease is recommended for service:

- John Deere Multi-Purpose HD Lithium Complex Grease
- Grease-Gard™ Premium Plus

Not all grease types are compatible; John Deere does not recommend mixing greases. If using any product other than the recommended grease in service, purge any remaining grease from the system prior to application. If this is not practical, grease twice as often until all old grease is purged from the system.

Service Engine

Lubricating Front Axle

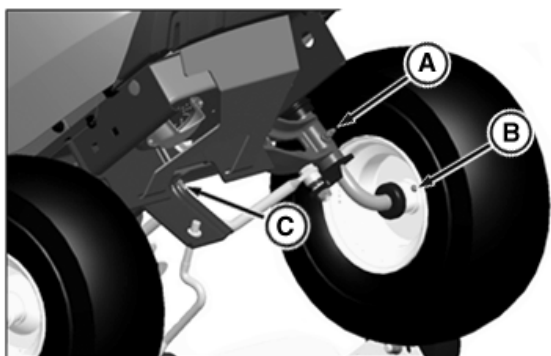

PY19182—UN—28JAN14

Wheel Spindles and Bushings

- Lubricate front wheel spindle grease fitting (A) and wheel hub grease fitting (B), one on each side, with one or two shots of general all-purpose grease.

Front Axle Pivot

- Lubricate front axle center pivot grease fitting (C) with one or two shots of general all-purpose grease.

Lubricating Pivot Points

107 cm (42 in.) Mower Deck:

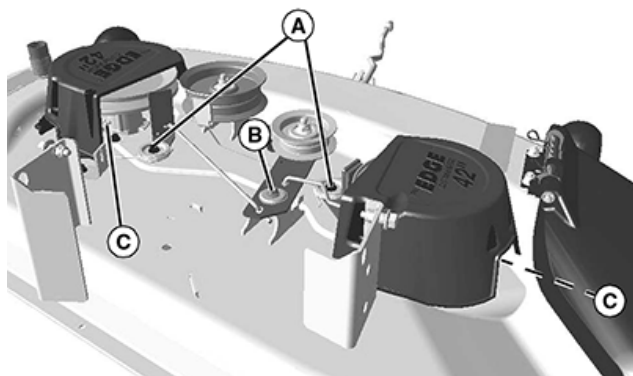

GXAL42005—UN—04MAR13

- A — Blade Brake Pivots
- B — Deck Idler Pivot
- C — Spindle Grease Fitting (2)

- Lubricate the blade brake pivots (A) and deck idler pivot (B) with a general all-purpose spray lubricant.
- Lubricate the two spindle grease fittings (C) with one or two shots of general all-purpose grease.

122 cm (48 in.) and 137 cm (54 in.) Mower Decks:

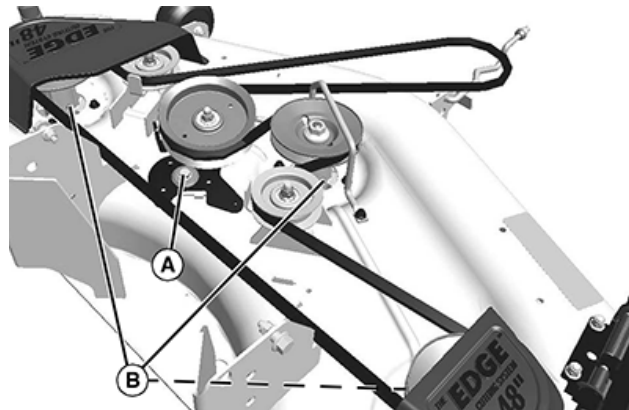

GXAL42006—UN—04MAR13

122 cm (48 in.) mower deck used for illustration

- A — Deck Idler Pivot
- B — Spindle Grease Fitting (3)

- Lubricate the deck idler pivot (A) with a general all-purpose spray lubricant.
- Lubricate the three spindle grease fittings (B) with one or two shots of general all-purpose grease.

Service Engine

Engine Warranty Maintenance Statement

Maintenance, repair, or replacement of the emission control devices and systems on this engine, which are being done at the customer's expense, may be performed by any non-road engine repair establishment or individual. Warranty repairs must be performed by an authorized John Deere dealer.

Emission Control System Certification Label

NOTE: Tampering with emission controls and components by unauthorized personnel may result in severe fines or penalties. Emission controls and components can only be adjusted by EPA and/or CARB authorized service centers. Contact your John Deere Retailer concerning emission controls and component questions.

The presence of an emissions label signifies that the engine has been certified with the United States Environmental Protection Agency (EPA) and/or California Air Resources Board (CARB).

The emissions warranty applies only to those engines marketed by John Deere that have been certified by the EPA and/or CARB; and used in the United States and Canada in off-road mobile equipment.

Avoid Fumes

CAUTION: Engine exhaust fumes contain carbon monoxide and can cause serious illness or death.

Do not run an engine in an enclosed area, such as a garage, even with doors or windows opened.

Move the machine to an outside area before running the engine.

Engine Oil

Use oil viscosity based on the expected air temperature range during the period between oil changes.

Service Engine

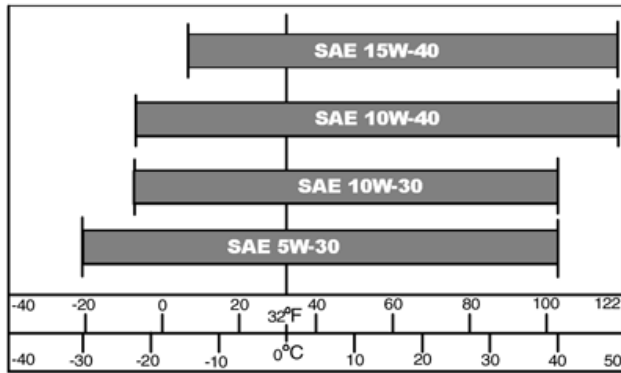

MXAL42826—UN—09APR13

The following John Deere oils are preferred:

- TURF-GARD™
- PLUS- 4™

Other oils may be used if above John Deere oils are not available, provided they meet the following specification:

- API Service Classification SJ or higher

Checking Engine Oil Level

IMPORTANT: Failure to check the oil level regularly could lead to serious engine problems if oil level is out of the operating range:

- Check oil level before operating.
- Check oil level when the engine is cold and not running.
- Keep oil level between the dipstick marks.
- Shut off engine before adding oil.

NOTE: Check oil twice a day if you run engine over 4 hours in a day. Make sure engine is cold when checking engine oil level.

1. Park machine safely. (See Parking Safely in the SAFETY section.)
2. Lift hood.
3. Clean area around dipstick to prevent debris from falling into crankcase.

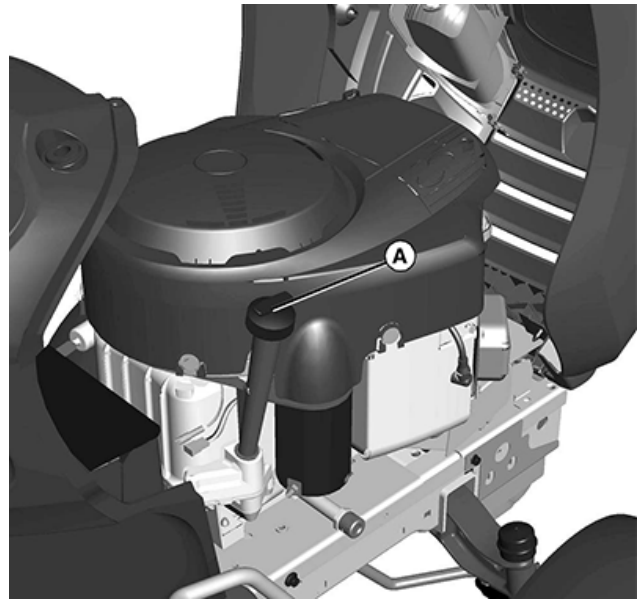

GXAL42008—UN—04MAR13

Twin cylinder engine shown

4. Remove dipstick (A). Wipe with clean cloth.
5. Install and tighten dipstick.
6. Remove dipstick.
7. Check oil level on dipstick. Oil must be between ADD and FULL marks.
8. If oil level is low, add oil to bring oil level no higher than FULL mark on dipstick. Do not overfill.
9. Install and tighten dipstick. Lower hood.

Changing Engine Oil and Filter

IMPORTANT: Change the oil more often if the vehicle is used in extreme conditions:

- Extremely dusty conditions.
- Frequent slow or low-speed operation.
- Frequent short trips.

1. Run engine to warm oil.
2. Park machine safely. (See Parking Safely in the SAFETY section.)
3. Lift hood.
4. Remove closeout panels.

Service Engine

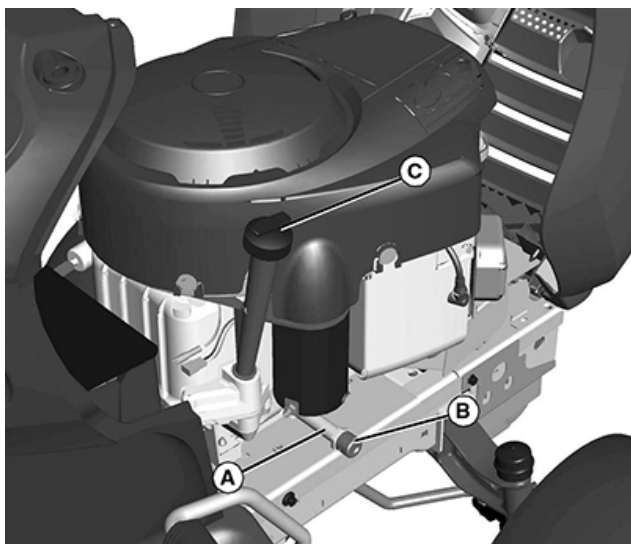

GXAL42009—UN—04MAR13

Twin cylinder engine shown

5. Put drain pan under drain valve (A).
6. Rotate and remove drain cap (B) and drain oil into oil drain pan. Allow oil to drain completely.
7. Remove dipstick (C).

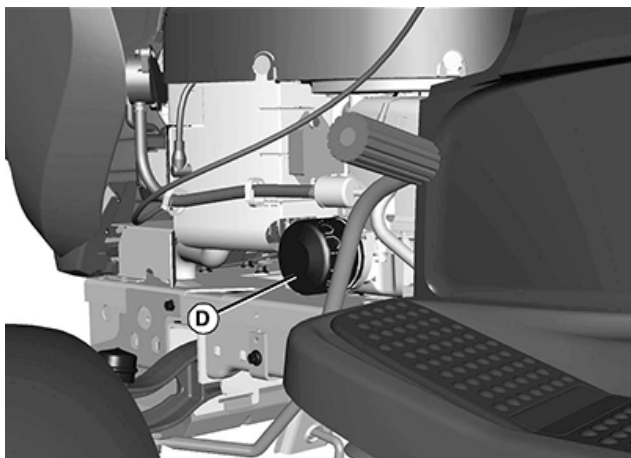

GXAL42010—UN—04MAR13

Twin cylinder engine shown

8. Replace oil filter (D), if equipped.
 - a. Wipe dirt from around oil filter.
 - b. Place a drain pan or funnel under filter tray.
 - c. Remove old filter and filter gasket and dispose of properly. Wipe up any spilled oil.
 - d. Put a light coat of fresh, clean oil on the new filter gasket.
 - e. Install replacement oil filter by turning oil filter to the right (clockwise) until the rubber gasket contacts filter base. Tighten filter an additional one-half turn.
9. Install drain cap.

IMPORTANT: Do not overfill. Overfilling can cause smoking, hard starting, fouling of spark plug, and oil saturation of air filter.

10. Add oil no higher than FULL mark on dipstick. Use approximately the amount of oil listed in the Specifications section. Do not overfill.
11. Install dipstick.

12. Start and run engine at idle to check for leaks. Stop engine. Fix any leaks before operating.
13. Check oil level. Add oil if necessary.
14. Install closeout panels and lower hood.

Cleaning Air Intake Screen and Engine Fins

CAUTION: Compressed air can cause debris to fly a long distance.

- Clear work area of bystanders.
- Wear eye protection when using compressed air for cleaning purposes.
- Reduce compressed air pressure to 210 kPa (30 psi).

IMPORTANT: An obstructed air intake screen can cause engine damage due to overheating. Keep air intake screen and other external surfaces of the engine, including cooling fins, clean at all times to allow adequate air intake.

1. Park machine safely. (See Parking Safely in the SAFETY section.)
2. Lift hood.

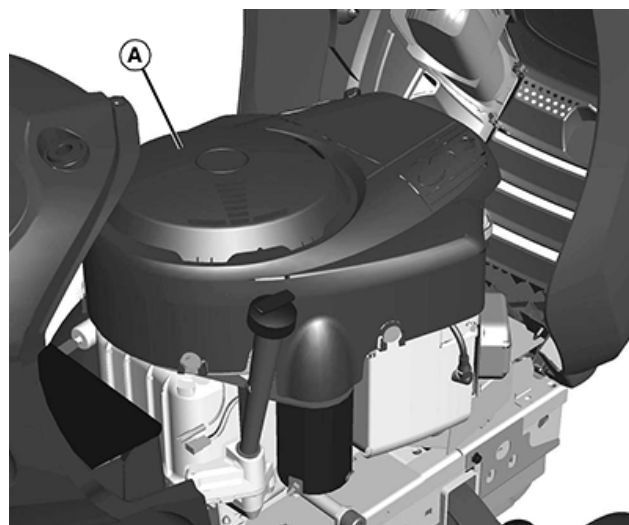

GXAL42011—UN—04MAR13

Twin cylinder engine shown

3. Clean air intake screen (A), cooling fins and external surfaces with rag, brush, vacuum or compressed air.
4. Lower hood.

Checking and Cleaning Air Cleaner Elements (D105 and D110)

1. Park machine safely. (See Parking Safely in the SAFETY section.)
2. Let engine cool.
3. Lift hood.
4. Clean dirt and debris from the air cleaner cover.

Service Engine

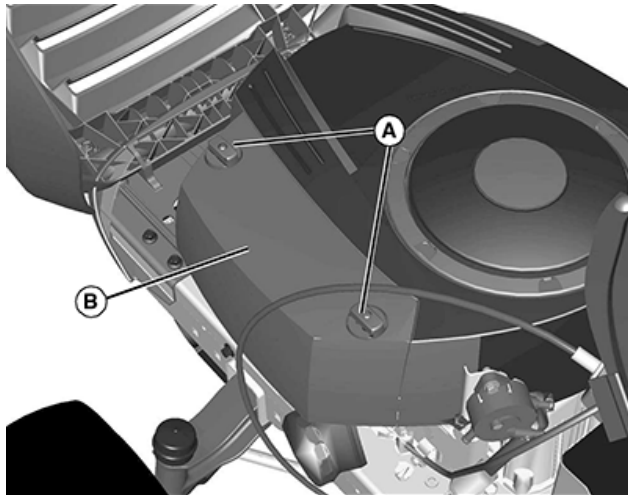

GXAL42016—UN—04MAR13

- Lift latch (A) to unlock cover (B). Lift cover forward and remove.

IMPORTANT: Dirt and debris can enter the engine through a damaged filter element:

- Do not wash paper element.
- Do not attempt to clean paper element by tapping against another object.
- Do not use pressurized air to clean element.
- Replace element only if it is very dirty, damaged or the seal is cracked.

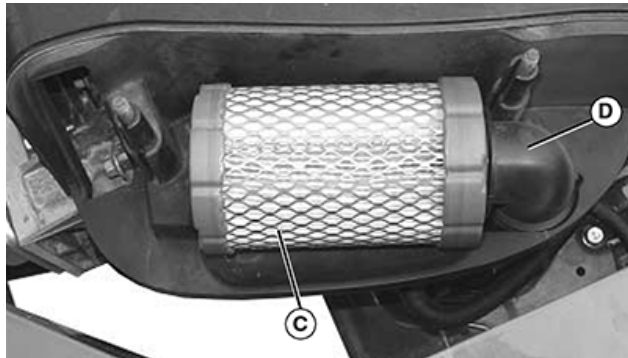

GXAL42013—UN—04MAR13

- Inspect the paper filter element (C) without removing it. If the paper filter element is damaged or dirty, replace with new filter:
 - Clean air cleaner base very carefully, preventing any dirt from falling into carburetor.
 - Carefully pull the paper element from the air cleaner elbow (D).
 - Install new paper filter element back onto air cleaner elbow.
- Install air cleaner cover and push latch down to lock.
- Lower hood.

Checking and Cleaning Air Cleaner Elements (D125, D130 and D140)

- Park machine safely. (See Parking Safely in the SAFETY section.)
- Let engine cool.
- Lift hood.
- Clean dirt and debris from the air cleaner cover.

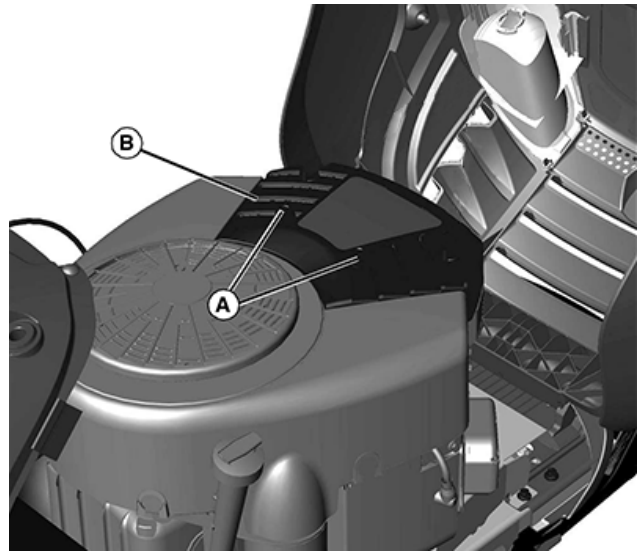

PY19032—UN—07AUG13

- Loosen knobs (A) and remove cover (B).

IMPORTANT: To prevent engine damage, do not allow any foreign objects to fall into the carburetor air intake.

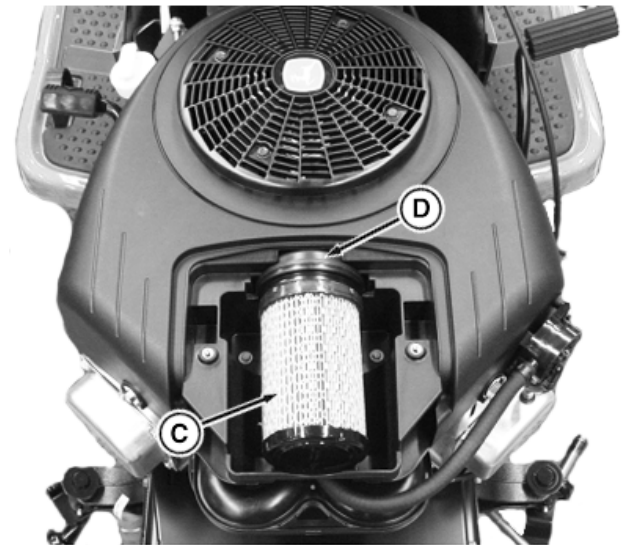

PY19029—UN—07AUG13

- Inspect the paper filter element (C) without removing it. If the paper filter element is damaged or dirty, replace with new filter:
 - Clean air cleaner base very carefully, preventing any dirt from falling into carburetor.
 - Carefully pull the paper element from the air cleaner seat (D).
 - Install new paper filter element back onto air cleaner seat.
- Install air cleaner cover and tighten knobs. Do not overtighten.
- Lower hood.

Checking and Cleaning Air Cleaner Elements (D155, D160 and D170)

- Park machine safely. (See Parking Safely in the SAFETY section.)
- Let engine cool.

Service Engine

- Lift hood.
- Clean dirt and debris from the air cleaner cover.

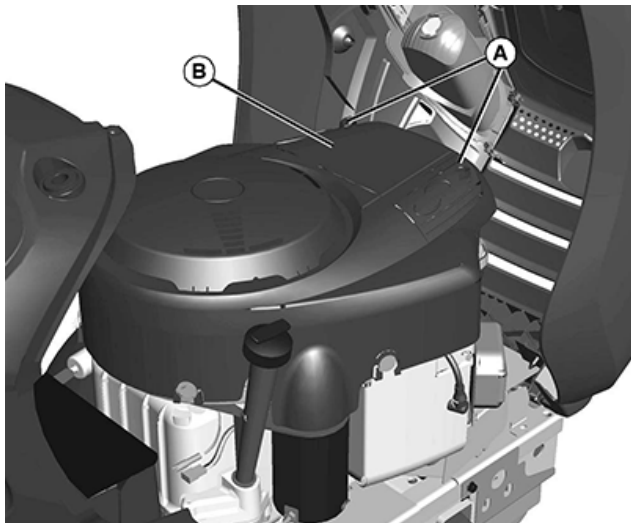

GXAL42018—UN—04MAR13

- Loosen two knobs (A) and remove cover (B).

IMPORTANT: Dirt and debris can enter the engine through a damaged filter element:

- Do not wash paper element.
- Do not attempt to clean paper element by tapping against another object.
- Do not use pressurized air to clean element.
- Replace element only if it is very dirty, damaged or the seal is cracked.

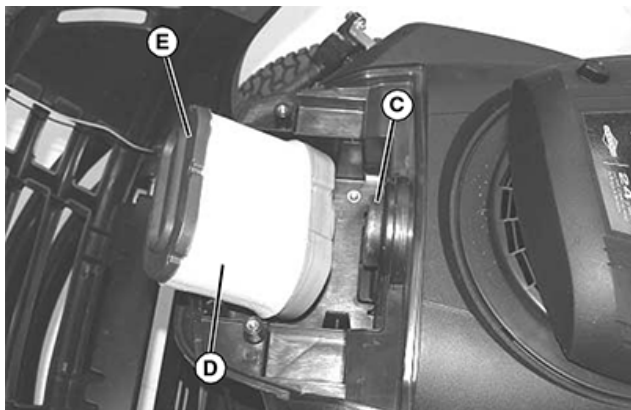

GXAL42019—UN—04MAR13

- Pull filter assembly from air cleaner base (C). Inspect the foam pre-cleaner (D) without removing it. If the foam pre-cleaner is dirty:
 - Remove it from the paper filter carefully.
 - Wash pre-cleaner in a solution of warm water and liquid detergent. Do not use oil.
 - Rinse pre-cleaner thoroughly. Squeeze out excess water in a dry cloth until pre-cleaner is completely dry.
- Inspect the paper filter element (E). If the paper filter element is damaged or dirty, replace with new filter.
- Clean air cleaner base very carefully, preventing any dirt from falling into carburetor.
- Install foam pre-cleaner on paper filter element.

- Install new filter assembly back onto air cleaner base.
- Install air cleaner cover and tighten two knobs.
- Lower hood.

Checking and Cleaning Emission Filter (If Equipped)

- Park machine safely. (See Parking Safely in the SAFETY section.)

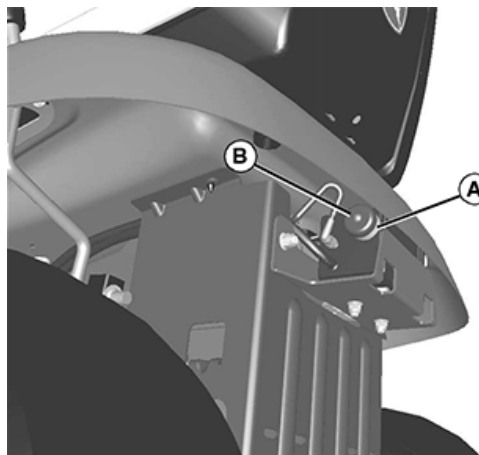

GXAL42020—UN—04MAR13

- Inspect filter (A) for dirt and damage, wash or replace if required.
 - Remove cover (B) and remove emission filter (A) from under rear of fender deck.
 - Wash foam filter in a solution of warm water and liquid detergent. Do not use oil.
 - Rinse filter thoroughly. Squeeze out excess water in a dry cloth until filter is completely dry.
If foam filter cannot be cleaned properly or is damaged, replace with a new filter.
 - Install foam air filter and secure with cover.

Checking Spark Plug

- Park machine safely. (See Parking Safely in the SAFETY section.)
- Let engine cool.
- Lift hood.

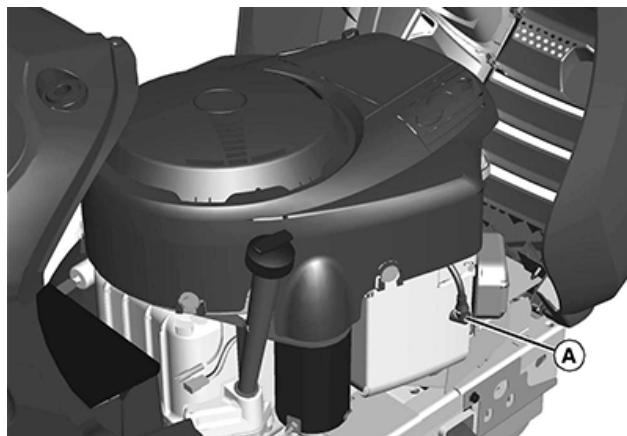

Twin cylinder engine shown

GXAL42021—UN—04MAR13

- Disconnect spark plug wire(s) (A), one on each side on V-twin engines.

Service Transmission

5. Remove spark plug(s).
6. Clean spark plug carefully with a wire brush.
7. Inspect spark plug for:
 - Cracked porcelain.
 - Pitted or damaged electrodes.
 - Other wear or damage.
8. Replace spark plug as necessary.

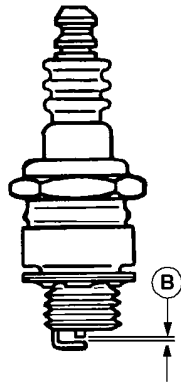

GXAL42022—UN—04MAR13

9. Check plug gap (B) with a wire feeler gauge. To change gap, move the outer electrode.
Gap must meet specifications.

Specification

Spark Plug — Gap 0.030 in. (0.76 mm)

10. Install and tighten spark plugs to specifications.

Specification

Spark Plug — Torque..... 15 lb-ft (20 N-m)

11. Connect spark plug wire(s) and lower hood.

Adjusting Carburetor

NOTE: Carburetor is calibrated by the engine manufacturer and is not adjustable.

If engine is operated at altitudes above 1006 m (3,300 ft), some carburetors may require a special high altitude main jet. See your authorized dealer.

If engine is hard to start or runs rough, check the TROUBLESHOOTING section of this manual.

Possible engine surging will occur at high throttle with transmission in "N" neutral and mower engagement lever disengaged. This is a normal condition due to the emission control system.

After performing the checks in the troubleshooting section and your engine is still not performing correctly, contact your authorized dealer.

Replacing Fuel Filter

NOTE: Change filter when fuel is low.

1. Park machine safely. (See Parking Safely in the SAFETY section.)
2. Let engine cool.
3. Lift hood.
4. Handle fuel safely. (See Handling Fuel Safely in the SAFETY section.)
5. Put a drain pan under fuel filter.

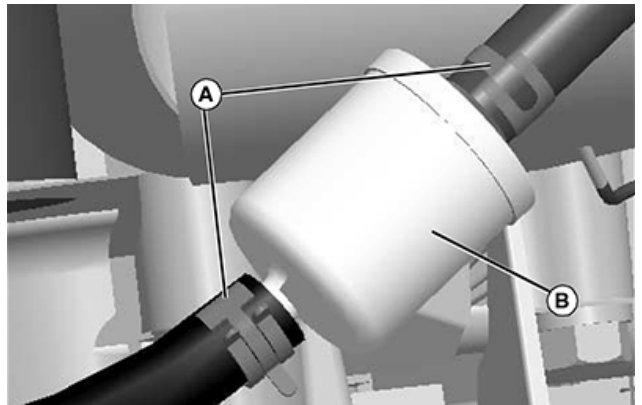

GXAL42023—UN—04MAR13

6. Slide hose clamps (A) away from fuel filter (B) using a pliers.
7. Disconnect hoses from filter, and raise fuel lines vertically to avoid fuel drainage.

IMPORTANT: Incorrect installation of fuel filter may cause engine damage. Install the filter with the arrow pointing in the direction of fuel flow (towards the engine) for proper operation.

8. Connect hoses to new filter making sure the filter arrow is pointed in the direction of the fuel flow.
9. Install clamps and check for leaks.
10. Lower hood.

Service Transmission

Checking Transmission

The transmission is a sealed component. No maintenance is required on this transmission. If you suspect any transmission problems, please contact your authorized dealer.

Service Mower

Removing or Installing Mower Drive Belt at Engine Drive Sheave 122 cm (48 in.) and 137 cm (54 in.) Mower Deck

1. Park machine safely. (See Parking Safely in SAFETY section.)
2. Put lift lever in lowest position.

Service Mower

CAUTION: Component is spring-assisted and under tension. Injury can occur if spring-assisted component is released suddenly.

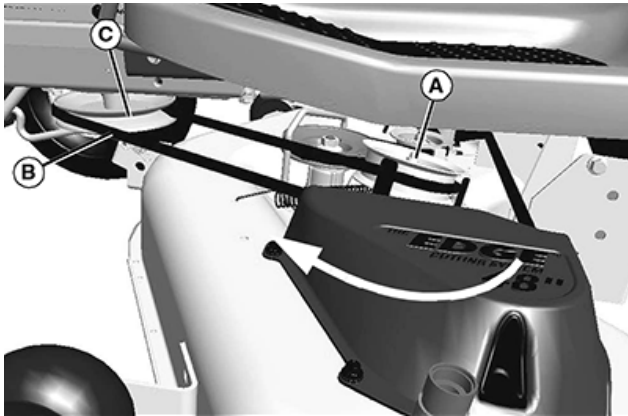

GXAL42024—UN—04MAR13

3. Put a 15 mm closed wrench or a socket on the idler sheave nut (A) and rotate clockwise to move idler sheave toward front of tractor and hold to release belt tension.
4. Remove belt (B) from drive sheave (C), and release tension on sheave nut (A).
5. To install the belt on the drive sheave, rotate idler sheave nut clockwise to move idler sheave toward front of tractor, and install belt on drive sheave.
6. Release idler sheave nut to tighten belt.

Removing Mower Deck

1. Park machine safely. (See Parking Safely in SAFETY section.)
2. Put wood blocks under each side of mower deck.
3. Put attachment lift lever in lowest position, bringing mower deck down onto blocks.

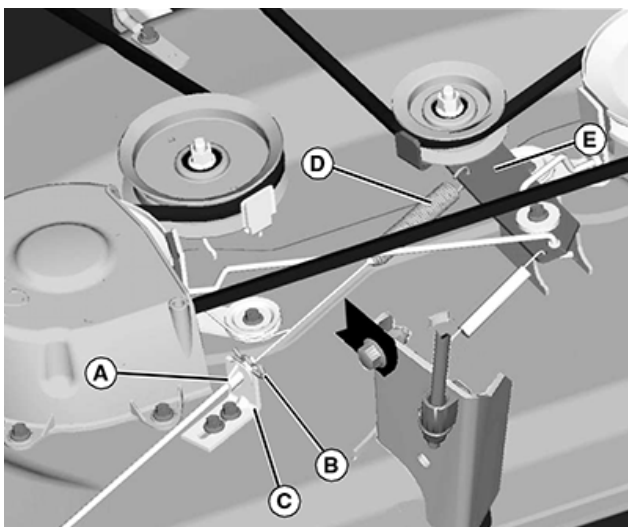

GXAL42025—UN—04MAR13

107 cm (42 in.) mower deck only

4. On machines with 107 cm (42 in.), disconnect mower engagement drive cable (A) on left side of mower deck.
 - a. Remove spring locking pin (B), pull and hold mower engagement drive cable out, lift up and remove from bracket (C).

- b. Remove cable spring (D) from idler sheave bracket (E).

CAUTION: Mower lift arms can pinch fingers. Lift arms are spring loaded and can snap back when deck is removed.

Lock lift lever before pulling pin to remove mower deck.

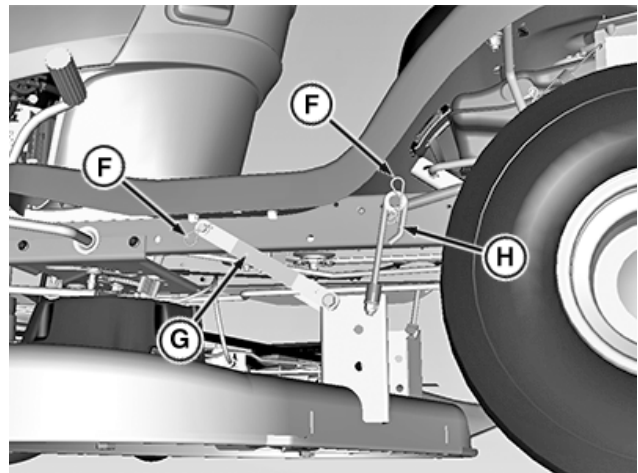

PY21332—UN—20AUG14

5. Remove spring locking pins and washers (F) and disconnect rear draft arm (G) and adjustable lift links (H) on each side.

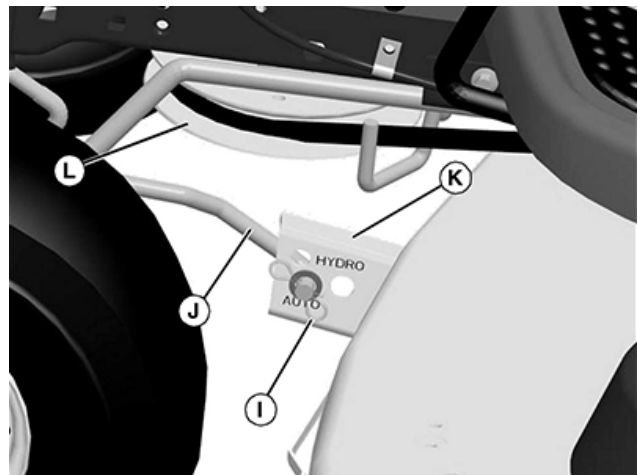

GXAL42027—UN—04MAR13

107 cm (42 in.) mower deck shown

6. Remove spring locking pin (I) and washer and front draft rod (J) from mower deck bracket (K).
7. Remove mower drive belt from drive sheave (L).
8. Remove wood blocks from both sides and slide mower deck out from under the machine.
9. When operating the machine without the mower deck:
 - Remove front draft rod from machine and attach it to the mower deck.

Service Mower

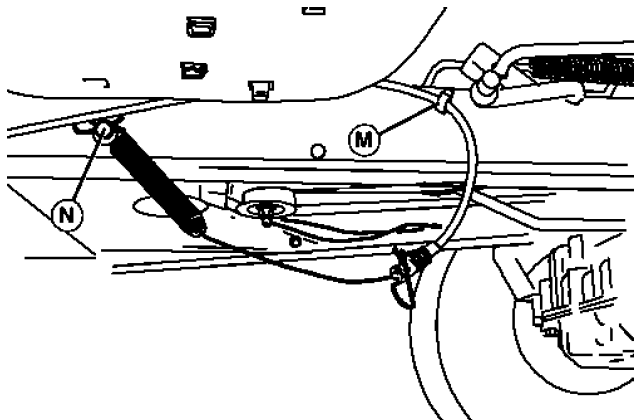

GXAL42028—UN—05MAR13

107 cm (42 in.) mower deck shown

- On 107 cm (42 in.) mower deck only: Push mower engagement drive cable into clip (M) and hook end of cable spring with hardware (N) into peg on left side of machine frame.

Installing Mower Deck

1. Park machine safely. (See Parking Safely in SAFETY section.)
2. Put attachment lift lever in the transport position.
3. Slide mower under machine.
4. Put wood blocks under each side of mower deck.
5. Put attachment lift lever in lowest position.

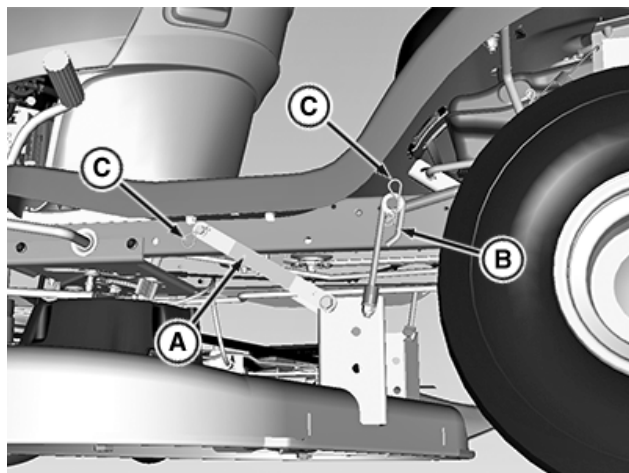

PY21326—UN—19AUG14

6. Fasten rear draft arm (A) and adjustable lift link (B), on each side, with washers and spring locking pins (C).

IMPORTANT: To prevent clutch damage, make sure front draft rod is installed correctly. Secure rod with washer and spring locking pin on the left side of mower deck bracket.

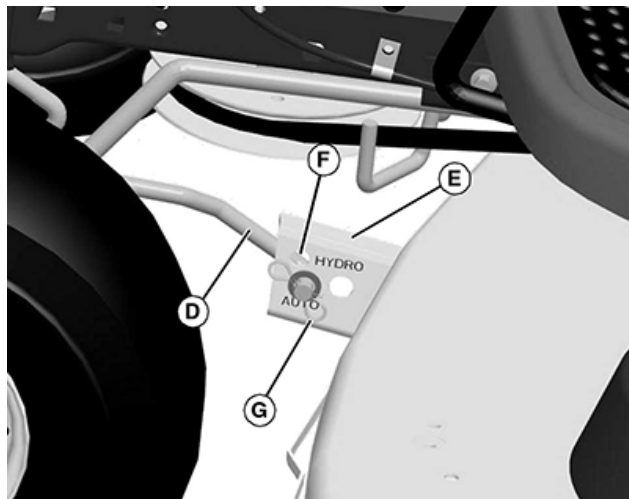

GXAL42030—UN—04MAR13

107 cm (42 in.) mower deck shown

7. Install front draft rod (D) into mower deck bracket (E):
 - For D105 models use the hole marked AUTO (shown).
 - For all other models use the hole marked HYDRO (F).
8. Secure front draft rod with washer and spring locking pin (G).

CAUTION: Component is spring-assisted and under tension. Injury can occur if spring-assisted component is released suddenly.

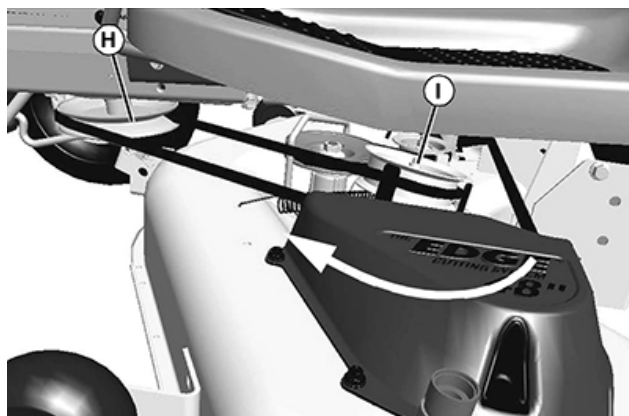

GXAL42031—UN—04MAR13

122 cm (48 in.) mower deck used for photo purposes.

9. Put mower drive belt on engine drive sheave (H).
 - On 122 cm (48 in.) and 137 cm (54 in.) mower decks: Put a 15 mm closed wrench or a socket on the idler sheave nut (I) and rotate clockwise, moving idler sheave and tensioning arm toward front of tractor. Hold while installing belt on drive sheave.

Service Mower

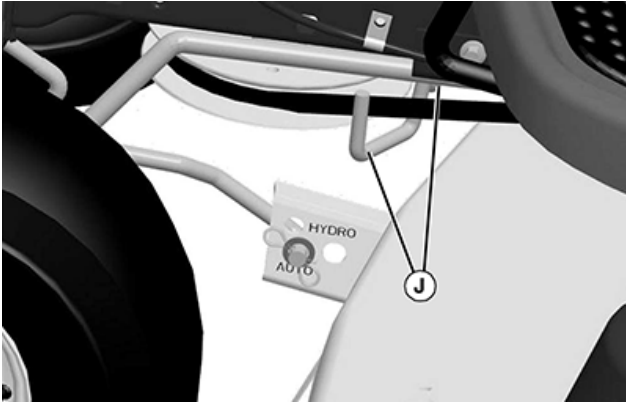

GXAL42032—UN—04MAR13

- On 107 cm (42 in.) mower deck: Make sure belt is routed through both belt guides (J).

10. Remove wood blocks from both sides of mower deck.
11. On machines with 107 cm (42 in.) mower deck: Attach mower engagement drive cable.

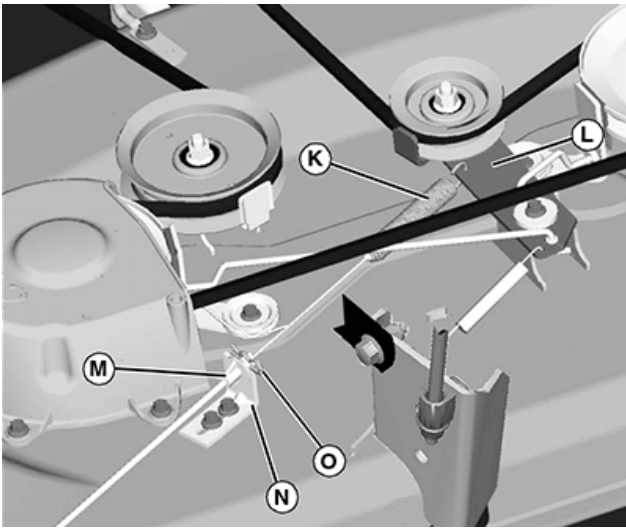

GXAL42033—UN—04MAR13

107 cm (42 in.) mower deck only

- a. Route cable under mower belt and brake rod and attach cable spring (K) to idler sheave bracket (L).
- b. Pull out on cable (M), align black end of cable with slot in bracket (N) and release cable into slot. Secure with spring locking pin (O).

12. Level mower deck.

Replacing Mower Drive Belt (107 cm (42 in.) Mower Deck)

1. Park machine safely. (See Parking Safely in the SAFETY section.)
2. Remove mower deck.

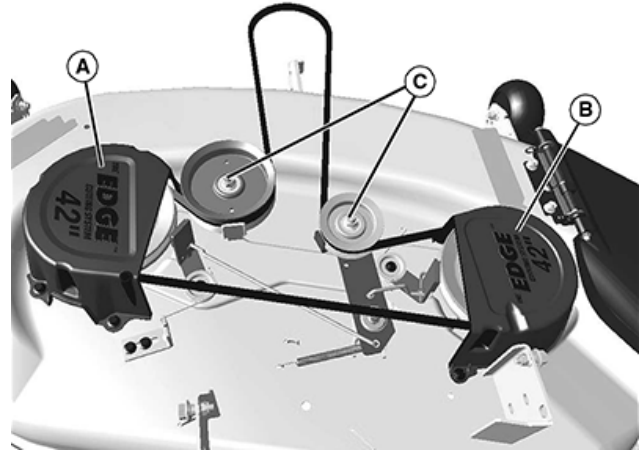

GXAL42034—UN—04MAR13

3. Remove drive belt:
 - a. Remove three capscrews and belt shield (A).
 - b. Remove two capscrews and belt shield (B).
 - c. Loosen sheaves (C).
 - d. Remove mower belt.
4. Inspect belt for wear or damage; replace as necessary.
5. Clean top surface of mower deck and sheaves.
6. Install belt on mower deck as shown. Make sure belt is in the groove of each sheave.
7. Tighten sheaves to specifications.

Specification	
Mower Deck Drive Sheave Nuts (107 cm (42 in.) Mower Deck)	
— Torque	35 lb-ft (47 N·m)
8. Install belt shields.
9. Install mower deck.
10. Adjust mower belt tension and spindle brakes, if necessary.

Replacing Mower Drive Belt (122 cm (48 in.) and 137 cm (54 in.) Mower Decks)

1. Park machine safely. (See Parking Safely in SAFETY section.)
2. Remove mower deck.

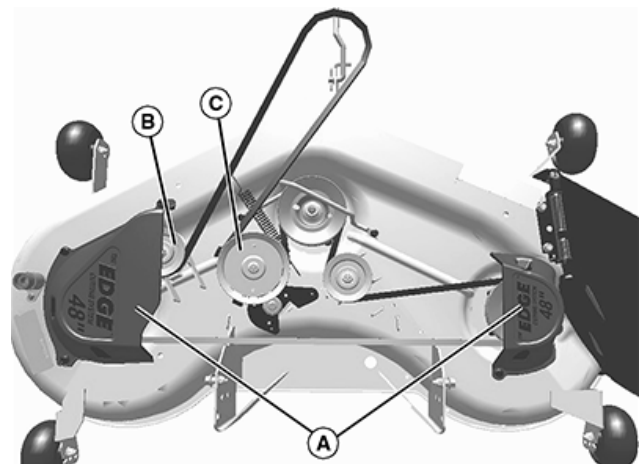

GXAL42035—UN—04MAR13

122 cm (48 in.) mower deck shown

3. Remove five capscrews and left and right belt shields (A).

Service Mower

4. Remove drive belt.
 - a. Loosen left side sheaves (B) and (C).
 - b. Remove mower belt.
5. Inspect belt for wear or damage; replace as necessary.
6. Clean top surface of mower deck and sheaves.
7. Install belt on mower deck as shown. Make sure belt is in the groove of each sheave.
8. Tighten sheaves to specifications.

Specification

Mower Deck Drive Sheave Nuts (122 cm (48 in.) and 137 cm (54 in.) Mower Deck)	
— Torque	47 N·m (35 lb-ft)

9. Install belt shields.
10. Install mower deck.

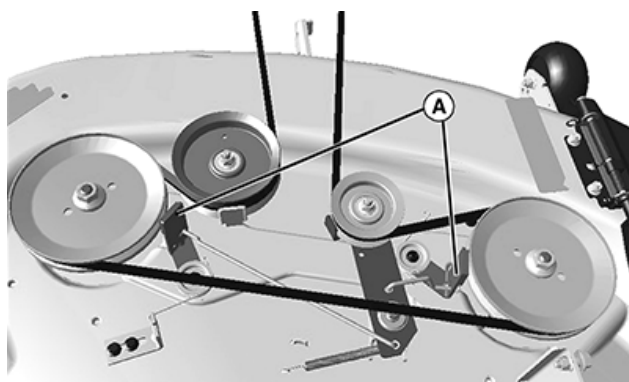

GXAL42037—UN—04MAR13

Adjusting Mower Belt Tension (107 cm (42 in.) Mower Deck)

1. Park machine safely. (See Parking Safely in the SAFETY section.)
2. Move mower engagement (PTO) lever or switch to OFF position.

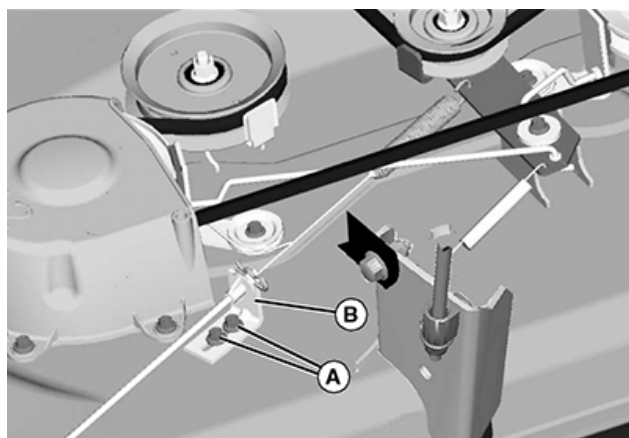

GXAL42036—UN—04MAR13

3. Loosen nuts (A) and move cable bracket (B) away from the center of mower deck to tighten belt tension. Move bracket until almost all slack is out of cable but cable is not too tight. Tighten nuts.

Adjusting Spindle Brakes (107 cm (42 in.) Mower Deck)

CAUTION: The mower blades should stop in approximately five seconds when the mower or PTO is disengaged.

If you believe that your blades may not be stopping in that period of time, take your machine to your authorized dealer where they can safely check and service your machine.

IMPORTANT: Avoid belt damage.

Spindle brake engagement should be checked and corrected every time the mower belt tension is adjusted.

Mower belt tension should be adjusted, if required, before brakes are adjusted.

1. Park machine safely. (See Parking Safely in the SAFETY section.)
2. Remove mower deck.

3. Remove left and right belt shields, and adjust two blade brakes (A).

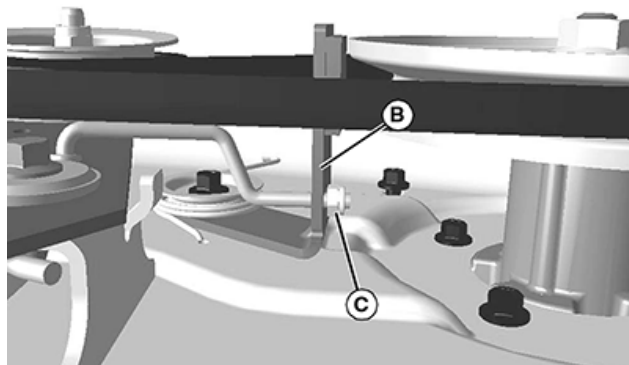

GXAL42038—UN—04MAR13

4. Measure distance from spindle brake bracket (B) to nut (C) on end of brake rod.
 - Bracket to nut distance should meet specifications.

Specification

Spindle Bracket-to-Nut — Distance	2 - 3 mm (0.08 - 0.12 in.)
-----------------------------------	----------------------------

5. If adjustment is required, turn nut (C) on end of brake rod in correct direction to set brake at proper distance from pulley.
6. Adjust both brakes.
7. Install left and right belt shields.
8. Install mower deck.

Checking for Bent Mower Blades

CAUTION: Blades are sharp. Always wear gloves when handling blades or working near blades.

Replace blades if defective. Never straighten or weld them.

1. Park machine safely. (See Parking Safely in the SAFETY section.)
2. Raise mower deck to highest position to access blades.

Service Mower

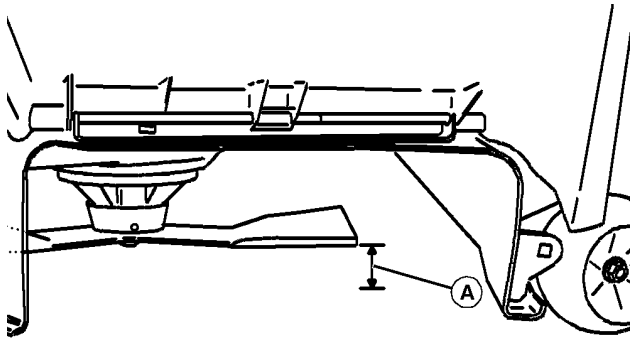

MXAL42867—UN—09APR13

Mower deck with side discharge used for illustration

3. Measure distance (A) between blade tip and flat ground surface.
4. Rotate blade 180° and measure distance between other blade tip and flat ground surface.
5. Install new blade if the difference between the two measurements is more than 3 mm (1/8 in.).
6. Repeat for all blades.

Servicing Mower Blades

CAUTION: Rotating blades are dangerous. Before adjusting or servicing mower:

Disconnect spark plug wire(s) or battery negative (-) cable to prevent engine from starting accidentally.

Always wear gloves when handling mower blades or working near blades.

Removing Mower Blades

1. Park machine safely. (See Parking Safely in SAFETY section.)
2. Raise mower deck to gain access to mower blades. If necessary, remove mower deck.
3. Block mower blade with a piece of wood to prevent it from spinning.

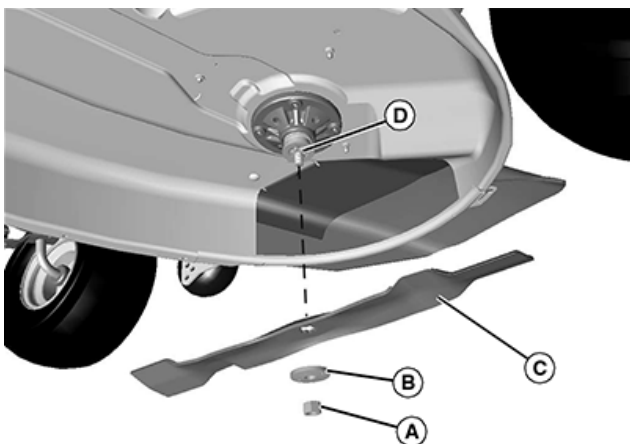

GXAL42040—UN—04MAR13

4. Loosen and remove nut (A), washer (B), and blade (C).
5. Inspect blades; sharpen, balance or replace blades as necessary.

Installing Mower Blades

1. Position mower blade (C) with the cutting edge towards the ground.
2. Align the splined center hole in the blade with the splined spindle shaft (D) and put the blade onto the mower spindle shaft.
3. Install washer, with cupped side towards blade, and install nut to secure blade onto splined spindle shaft.
4. Block mower blade with a piece of wood to prevent spinning and tighten nut:
5. Using 15/16 in. socket, tighten 5/8 in. blade nut to specifications.

Specification

Mower Deck Blade Nut — Torque 88 N·m (65 lb-ft)

Sharpening Blades

CAUTION: Blades are sharp. Always wear gloves when handling blades or working near blades.

Always wear safety eye protection when grinding.

- Sharpen blades with grinder, hand file, or electric blade sharpener.

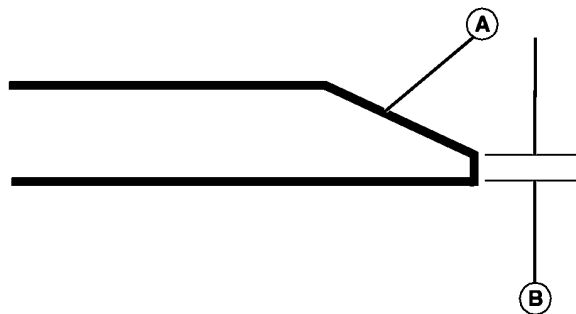

GXAL42041—UN—04MAR13

- Keep original bevel (A) when grinding.
- The blade cutting edge (B) should meet specifications.

Specification

Mower Blade Cutting Edge — Distance 0.40 mm (1/64 in.)

- Balance blades before installing.

Balancing Blades

CAUTION: Blades are sharp. Always wear gloves when handling blades or working near blades.

1. Clean blade.

Service Electrical

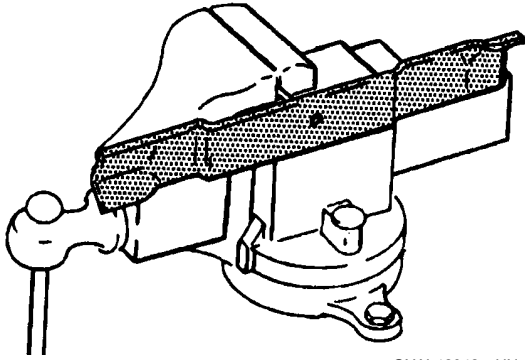

GXAL42042—UN—04MAR13

2. Put blade on nail in a vise. Turn blade to horizontal position.
3. Check balance. If blade is not balanced, heavy end of blade will drop.
4. Grind bevel of heavy end. Do not change blade bevel.

Service Electrical

Electrical

WARNING: Battery posts, terminals and related accessories contain lead and lead components, chemicals known to the State of California to cause cancer and reproductive harm. **Wash hands after handling.**

Service the Battery Safely



MXAL42869—UN—09APR13

CAUTION: The battery produces a flammable and explosive gas.

The battery may explode:

- Do not smoke or have open flame near battery.
- Wear eye protection and gloves.
- Do not allow direct metal contact across battery posts.
- Remove negative cable first when disconnecting.
- Install negative cable last when connecting.

Removing and Installing the Battery

Removing

1. Park machine safely and lift hood. (See Parking Safely in the SAFETY Section.)

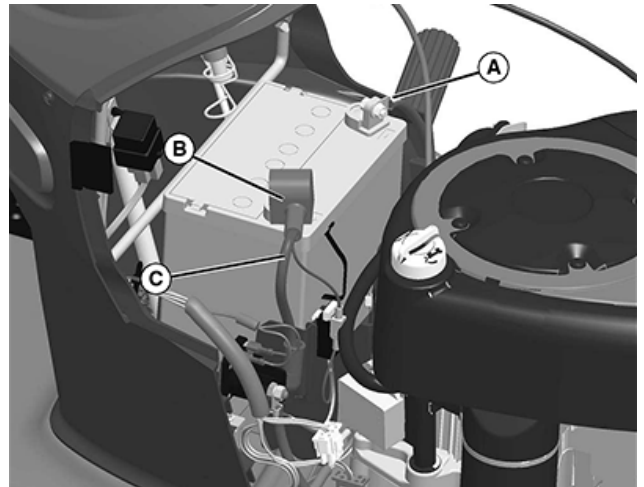

GXAL42044—UN—04MAR13

2. Disconnect negative (-) battery cable (A).
3. Push red cover (B) away from positive (+) battery terminal and remove cable (C) from battery.
4. Remove battery.

Installing

1. Place battery into battery tray.
2. Connect positive (+) cable to positive (+) battery terminal first, then negative (-) cable to negative (-) battery terminal.
3. Apply spray lubricant to terminal to help prevent corrosion.
4. Slide red cover over positive battery terminal.

Cleaning Battery and Terminals

1. Park machine safely. (See Parking Safely in the SAFETY section.)
2. Disconnect and remove battery.
3. Wash battery with solution of four tablespoons of baking soda to one gallon of water. Be careful not to get the soda solution into the cells.
4. Rinse the battery with plain water and dry.
5. Clean terminals and battery cable ends with wire brush until bright.
6. Install battery.
7. Attach cables to battery terminals, beginning with the positive cable, using washers and nuts.
8. Apply spray lubricant to terminal to prevent corrosion.

Service Electrical

Using Booster Battery

CAUTION: The battery produces a flammable and explosive gas.

The battery may explode:

- Do not smoke or have open flame near battery.
- Wear eye protection and gloves.
- Do not jump start or charge a frozen battery. Warm battery to specification.

Specification

Battery — Temperature 16°C (60°F)

- Do not connect the negative (-) booster cable to the negative (-) terminal of the discharged battery. Connect at a good ground location away from the discharged battery.

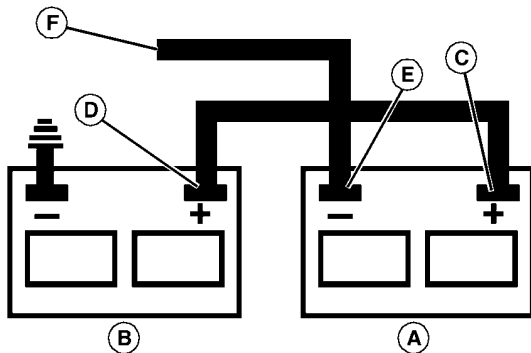

MXAL42872—UN—09APR13

A — Booster Battery
B — Disabled Vehicle Battery

1. Connect positive (+) booster cable to booster battery (A) positive (+) post (C).
2. Connect the other end of positive (+) booster cable to the disabled vehicle battery (B) positive (+) post (D).
3. Connect negative (-) booster cable to booster battery negative (-) post (E).

IMPORTANT: Electric charge from booster battery can damage machine components. Do not install negative booster cable to machine frame. Install only to the engine block.

Install negative booster cable away from moving parts in the engine compartment, such as belts and fan blades.

4. Connect the other end (F) of negative (-) booster cable to a metal part of the disabled machine engine block away from battery.
5. Start the engine of the disabled machine and run machine for several minutes.
6. Carefully disconnect the booster cables in the exact reverse order: negative cable first and then the positive cable.

Replacing Headlight Bulb

1. Park machine safely. (See Parking Safely in the SAFETY section.)
2. Lift hood.



GXAL42046—UN—04MAR13

3. Turn bulb socket (A) 1/4 turn counterclockwise to remove.
4. Replace defective bulb with a new bulb.
5. Insert bulb socket into housing, push in and turn 1/4 turn clockwise to install.
6. Lower hood.

Replacing Fuse

1. Park machine safely. (See Parking Safely in the SAFETY section.)
2. Lift hood.

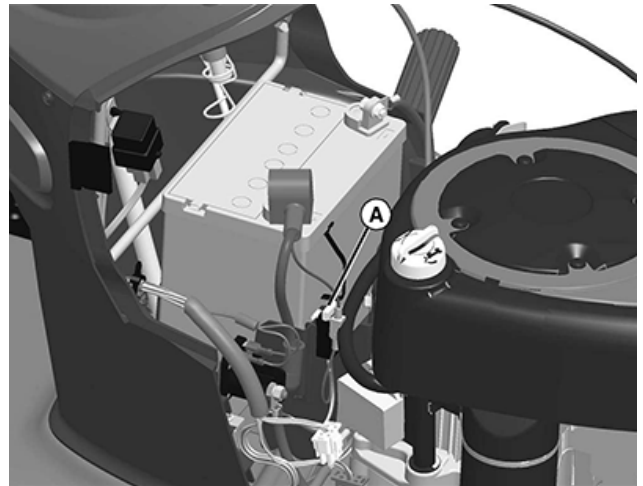

GXAL42047—UN—04MAR13

3. Pull defective fuse (A) out of socket.
4. Check metal clip in fuse window and discard fuse if clip is broken.
5. Push new 20 amp fuse into socket.
6. Lower hood.

Service Miscellaneous

Service Miscellaneous

Using Proper Fuel and Stabilizer

IMPORTANT: Using stale, contaminated or improper fuel can result in engine and fuel system damage. Repairs caused by stale, contaminated or improper fuel are not covered by warranty.

Use regular grade unleaded fuel with an octane rating of 87 octane or higher. Fuel blends containing up to 10% ethanol or up to 15% MTBE reformulated fuel are acceptable. Do not use fuel or additives containing methanol as engine damage can occur.

Always use fresh, clean fuel that is purchased in a quantity that can be used within approximately 30 days. Fuel stabilizer should always be added to the fuel each time fuel is purchased. Add stabilizer before filling the fuel container to insure proper mixing. Such practice helps prevent engine performance problems and allows fuel storage in the machine all year without draining.

Store fuel in plastic containers to reduce condensation. Make sure the cap on the fuel container is tight to reduce fuel contamination and evaporation. For best fuel storage life, use a self-sealing gas can.

Fuel is blended to give best seasonal performance. To avoid engine performance problems such as hard starting or vapor lock, use in-season fuel. Use fuel during warm weather that was purchased during that season, and use fuel during cold weather that was purchased during that season.

Fuel can become stale in machines with engines that are used seasonally or infrequently during a season. Stale fuel can produce varnish and plug carburetor or EFI components which can affect engine performance.

Keep fuel storage container tightly covered and in a cool area out of direct sunlight. Fuel can break down and degrade if not sealed properly or exposed to sun and heat.

Condensation may collect in the fuel tank because of a variety of operating or environmental conditions and, over time, may affect your machine's operation. Fill machine fuel tank at the end of the day.

Filling Fuel Tank

CAUTION: Fuel vapors are explosive and flammable:

- Shut engine off before filling fuel tank.
- Allow engine to cool before refueling.
- Do not smoke while handling fuel.
- Keep fuel away from flames or sparks.
- Fill fuel tank outdoors or in well ventilated area.
- Clean up spilled fuel immediately.
- Use clean approved non-metal container to prevent static electric discharge.

IMPORTANT: Dirt and water in fuel can cause engine damage:

- Clean dirt and debris from the fuel tank opening.
- Use clean, fresh, stabilized fuel.
- Fill the fuel tank at the end of each day's operation to keep condensation out of the fuel tank.
- Use a non-metallic funnel with a plastic mesh strainer when filling the fuel tank or container.

Fill fuel tank at the end of each day's operation to prevent condensation and freezing during cold weather.

1. Park machine safely. (See Parking Safely in the SAFETY section.)
2. Allow engine to cool.

3. Remove any trash from area around fuel tank cap.
4. Remove fuel tank cap slowly to allow any pressure built up in tank to escape.
5. Fill fuel tank only to bottom of filler neck. Do not overfill.
6. Install fuel tank cap.
 - Gas models: Turn cap until clicks.

Lifting Machine

1. Park machine safely. (See Parking Safely in the SAFETY section.)

CAUTION: The machine can fall or slip from an unsafe lifting device or supports.

- Use a safe lifting device rated for the load to be lifted.
- Lower machine onto jack stands or other stable supports and block wheels before servicing.

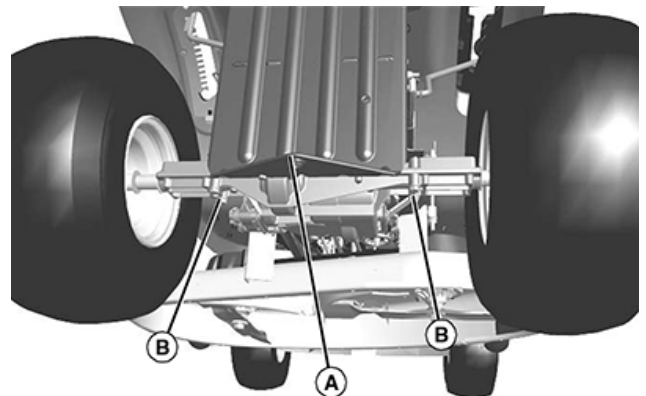

GXAL42048—UN—04MAR13

Hydrostatic transmission model shown

2. Safely lift rear of machine at machine frame point (A). Place jack stands or other stable supports onto transaxle locations (B) where mounting bolts for frame come through.
3. If only lifting rear of machine, block front wheels remaining on ground to avoid movement of machine.

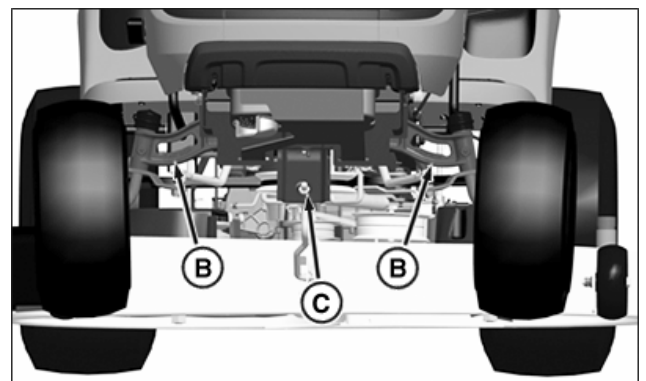

PY19194—UN—27JAN14

4. Safely lift front of machine at machine frame point (C). Place jack stands or other stable supports under frame on each side at location (B).
5. If only lifting front of machine, block rear wheels remaining on ground to avoid movement of machine.
6. To lower machine, lift front and/or rear of machine, and remove jack stands or supports. Lower machine.

Service Miscellaneous

Checking Tire Pressure

CAUTION: Explosive separation of tire and rim parts is possible when they are serviced incorrectly:

- Do not attempt to mount a tire without the proper equipment and experience to perform the job.
- Do not inflate the tires above the recommended pressure.
- Do not weld or heat a wheel and tire assembly. Heat can cause an increase in air pressure resulting in an explosion. Welding can structurally weaken or deform the wheel.
- Do not stand in front or over the tire assembly when inflating. Use a clip-on chuck and extension hose long enough to allow you to stand to one side.

1. Check tires for damage.

NOTE: Refer to the SPECIFICATIONS section for tire pressures or check the side of the tire.

2. Check tire pressure with an accurate lower pressure gauge.
3. Add or remove air, if necessary.

Removing and Installing Hood

Removing

CAUTION: Touching hot surfaces can burn skin. The engine, components, and fluids will be hot if the engine has been running. Allow the engine to cool before servicing or working near the engine and components.

IMPORTANT: Do not operate machine with hood open. Hood must be closed for proper engine cooling and exhaust.

1. Park machine safely. (See Parking Safely in the SAFETY section.)
2. Let engine cool.



PY19053—UN—07AUG13

3. Open hood.
4. Disconnect wiring harness (A).



PY21317—UN—12AUG14

5. Apply pressure to the pointed position on left side of hood and slowly lower hood. Left side pivot will release after rotating closed approximately 45 degrees. Once left side pivot releases, slide out right side pivot. Lower hood slightly and lift hood from brackets (B).

Installing

1. Slide right side hood pivot into tractor bracket with hood in open position (left side pivot slides into place as hood closes) and slowly close hood.
2. Connect wiring harness.
3. Close hood.

Cleaning Plastic Surfaces

IMPORTANT: Improper care of machine plastic surfaces can damage that surface:

- Do not wipe plastic surfaces when they are dry. Dry wiping will result in minor surface scratches.
- Use a soft, clean cloth (bath towel, diaper, automotive mitt).
- Do not use abrasive materials, such as polishing compounds, on plastic surfaces.

1. Rinse hood and entire machine with clean water to remove dirt and dust that may scratch the surface.
2. Wash surface with clean water and a mild liquid automotive washing soap.

IMPORTANT: Insect repellent spray may damage plastic and painted surfaces. Do not spray insect repellent near machine.

3. Dry thoroughly to avoid water spots.
4. Wax the surface with a liquid automotive wax. Use products that specifically say "contains no abrasives."

IMPORTANT: Do not use a power buffer to remove wax.

5. Buff applied wax by hand using a clean, soft cloth.

Cleaning and Repairing Metal Surfaces

Cleaning:

Follow automotive practices to care for your vehicle painted metal surfaces. Use a high-quality automotive wax regularly to maintain the factory look of your vehicle's painted surfaces.

Repairing Minor Scratches (surface scratch):

1. Clean area to be repaired thoroughly.

IMPORTANT: Do not use rubbing compound on painted surfaces.

Service Miscellaneous

2. Use automotive polishing compound to remove surface scratches.
3. Apply wax to entire surface.

Repairing Deep Scratches (bare metal or primer showing):

1. Clean area to be repaired with rubbing alcohol or mineral spirits.
2. Use paint stick with factory-matched colors available from your authorized dealer to fill scratches. Follow directions included on paint stick for use and for drying.
3. Smooth out surface using an automotive polishing compound. Do not use power buffer.
4. Apply wax to surface.

Removing and Installing Front Wheel Assembly

Removing:

1. Park machine safely. (See Parking Safely in the SAFETY section.)

CAUTION: The machine can fall or slip from an unsafe lifting device or supports.

- Use a safe lifting device rated for the load to be lifted.
- Lower machine onto jack stands or other stable supports and block wheels before servicing.

IMPORTANT: Place jack stands under frame, not under transmission or engine, when raising or supporting machine.

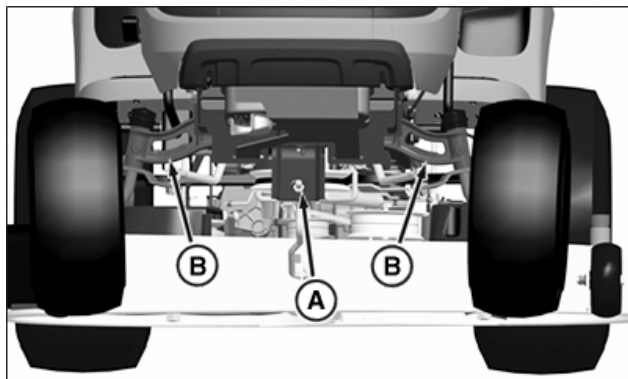

PY19183—UN—23JAN14

2. Safely lift and support machine. Place safe lifting device under end of front hanger bracket at location (A), and place jack stands or other stable supports under frame on each side at location (B). Block wheels remaining on the ground to prevent machine movement.



GXAL42052—UN—04MAR13

3. Remove plastic cap (C) from end of wheel hub.

CAUTION: Components are installed under spring tension. Wear eye protection and use proper tools when installing and removing components with spring tension.



GXAL42053—UN—04MAR13

4. Remove snap ring (D) from end of axle.
5. Remove washer (E) and wheel from axle.

CAUTION: Explosive separation of tire and rim parts is possible when they are serviced incorrectly:

- Do not attempt to mount a tire without the proper equipment and experience to perform the job.

6. Take wheel assembly to an authorized service dealer for repairs.

Installing

1. Grease spindles and wheel hub grease fittings with specified grease.
2. Install wheel and washer (E) on axle.
3. Install snap ring (D).
4. Install plastic cap (C).
5. Safely remove jack stands and lower machine.

Removing and Installing Rear Wheel Assembly

Removing

1. Park machine safely. (See Parking Safely in the SAFETY section.)

Troubleshooting

CAUTION: The machine can fall or slip from an unsafe lifting device or supports.

- Use a safe lifting device rated for the load to be lifted.
- Lower machine onto jack stands or other stable supports and block wheels before servicing.

IMPORTANT: Place jack stands under frame, not under transmission or engine, when raising or supporting machine.

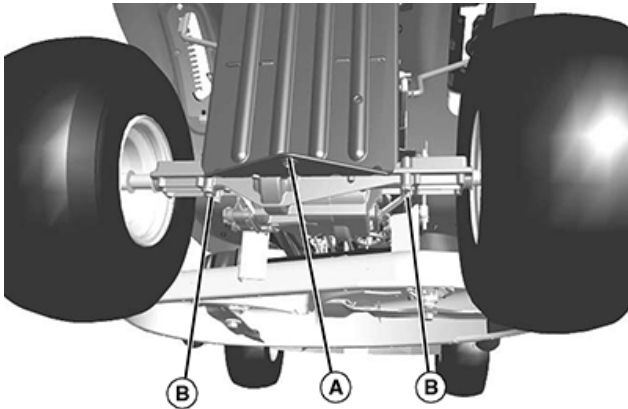

GXAL42054—UN—04MAR13

2. Safely lift and support machine. Place safe lifting device under transmission centered under machine frame point (A). Place jack stands or other stable supports on each side (B) where mounting bolts for frame come through. Block wheels remaining on the ground to prevent machine movement.

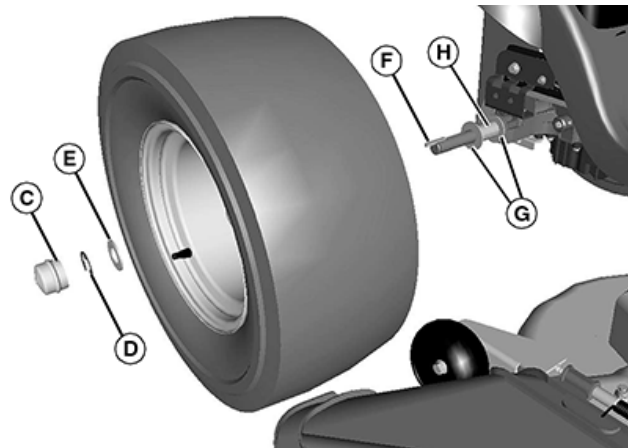

GXAL42055—UN—04MAR13

3. Remove plastic cap (C), snap ring (D), and washer (E).
4. Remove wheel.

IMPORTANT: Do not lose the shaft key. Key must be installed for wheels to rotate and tractor to move.

5. Remove shaft key (F) (shown on end of transmission shaft), two washers (G), except for model D105, and spacer (H).

CAUTION: Explosive separation of tire and rim parts is possible when they are serviced incorrectly:

- Do not attempt to mount a tire without the proper equipment and experience to perform the job.

6. Take wheel assembly to an authorized service dealer for repairs.

Installing

IMPORTANT: Do not lose the shaft key. Key must be installed for wheels to rotate and tractor to move.

NOTE: Rear wheels are installed with valves to the outside.

1. Install two washers (G), except on model D105, spacer (H), and shaft key (F).
2. Install rear wheel, washer (E), snap ring (D) and plastic cap (C).
3. Safely remove jack stands and lower machine.

Troubleshooting

Using Troubleshooting Chart

If you are experiencing a problem that is not listed in this chart, see your authorized dealer for service.

When you have checked all the possible causes listed and you are still experiencing the problem, see your authorized dealer.

Engine

IF	CHECK
Poor Engine Performance	Dirt in fuel system or fuel is old. Replace fuel with fresh stabilized fuel. Obtain fuel from another supplier before suspecting machine problems. Suppliers blend fuels differently and changing suppliers will generally solve any performance problems. Fuel blended with alcohol or ether may contribute to performance problems by causing gum and varnish deposits, especially if fuel is stored for several weeks or more. Obtain fresh fuel.
Engine Will Not Start	Brake pedal not depressed. Mower is engaged. Spark plug wire is loose or disconnected. Improper fuel. Transmission is in reverse. Plugged fuel filter. Defective safety switch. Electrical problem - See Electrical Troubleshooting Section
Engine Is Hard To Start	Carburetor is not adjusted properly or dirty. Choke cable not adjusted properly. Plugged fuel filter. Faulty spark plug. Stale or improper fuel. Loose or corroded electrical connections. Improper engine oil viscosity.
Engine Runs Unevenly	Cooling fins plugged. Loose electrical connections. Choke or throttle cable sticking. Fuel line or fuel filter plugged. Stale or dirty fuel. Improper fuel. Air cleaner element plugged.
Engine Misses Under Load	Faulty spark plug. Stale or dirty fuel. Plugged fuel filter.
Engine Vapor Locks	Fuel tank vent plugged. Dirt in fuel filter. Cooling fins plugged.

Storage

IF	CHECK
	Loose hose connection at fuel filter or fuel pump.
Engine Overheats	Engine air intake screen plugged. Cooling fins plugged. Engine oil low or too high. Engine operated too long at a slow idle speed.
Engine Will Not Idle	Spark plug not gapped correctly. Faulty spark plug. Operator raising off the seat.
Engine Knocks	Stale or low octane fuel. Engine overloaded. Low engine speed. Oil level low.
Engine Stops Or Misses When Operating On Hillsides	Fuel tank less than half full of fuel. Operator raising off of the seat.
Engine Backfires	Faulty spark plug. Operator raising off of the seat.
Engine Loses Power	Engine overheating. Too much oil in engine. Dirty air cleaner. Faulty spark plug. Travel speed is too fast for conditions. Improper fuel.
Excessive Fuel Consumption	Choke is not fully open.
Black Exhaust Smoke	Air filter is dirty or oil soaked. Choke partially engaged.
Engine Stops When REVERSE Foot Pedal Is Depressed And Attachment Is Engaged (Hydrostatic)	Normal condition. (See Using Reverse Implement Option in the OPERATING section.)
Engine Stops When Automatic Shift Lever Is Moved To The R (REVERSE) Position and Attachment Is Engaged (Automatic)	Normal condition. (See Using Reverse Implement Option in the OPERATING section.)

Electrical

IF	CHECK
Starter Does Not Work Or Will Not Turn Engine	Brake pedal is not depressed. Mower is engaged. Battery terminals are corroded. Battery not charged. Transmission is in reverse. Blown fuse.
Battery Will Not Charge	Dead cell in the battery. Battery cables and terminals are dirty. Low engine speed or excessive idling.
Lights Do Not Work	Light plug disconnected. Loose or burned out bulb.

Tractor

IF	CHECK
Tractor Vibrates Too Much Or Rattles Excessively	Attachment drive belts worn or damaged. Traction drive belt damaged or worn. Dirt on drive sheaves. Blades bent or out of balance.
Tractor Will Not Move With Engine Running	Parking brake locked. Bypass rod is pulled out.

Mower

IF	CHECK
Discharge Chute Plugged	Travel speed too fast. Grass too long. Grass too wet. Engine rpm not at wide open throttle. Restricted air flow. Belt installed incorrectly.
Patches Of Grass Uncut	Travel speed too fast. Engine rpm not at wide open throttle. Mower deck needs cleaning.
Belt Slipping	Debris in sheaves. Worn belt. Belt tension is incorrect.
Too Much Vibration	Debris on mower deck or in sheaves. Damaged drive belt. Damaged sheaves or sheaves out of alignment. Blades out of balance.
Blades Scalping Grass	Cutting too low. Mower wheels not adjusted correctly. Turning speed too fast. Ridges in terrain. Rough or uneven terrain. Low tire pressure.
Mower Loads Down Tractor	Engine rpm too low. Travel speed too fast. Debris wrapped around mower spindles.
Uneven Cut	Mower deck not leveled properly. Travel speed too fast. Blades dull. Mower wheels not adjusted correctly. Tire pressure unequal.
Mower (Or Other Attachment) Stops When Vehicle Is Operated in REVERSE	Normal condition. (See Using Reverse Implement Option in the OPERATING section.)

Storage

Storing Safety



CAUTION: Fuel vapors are explosive and flammable.

Engine exhaust fumes contain carbon monoxide and can cause serious illness or death:

- Run the engine only long enough to move the machine to or from storage.
- Machine fires and structure fires can occur if a machine is stored before allowing it to cool, or if debris is not removed from around the engine and muffler, or if stored near combustible materials.
- Do not store vehicle with fuel in the tank inside a building where fumes may reach an open flame or spark.
- Allow the engine to cool before storing the machine in any enclosure.

Preparing Machine for Storage

1. Repair any worn or damaged parts. Replace parts if necessary. Tighten loose hardware.
2. Repair scratched or chipped metal surfaces to prevent rust.
3. Remove grass and debris from machine.
4. Clean under the deck and remove grass and debris from inside chute and bagger.

Specifications

5. Wash the machine and apply wax to metal and plastic surfaces.
6. Run machine for five minutes to dry belts and pulleys.
7. Apply light coat of engine oil to pivot and wear points to prevent rust.
8. Lubricate grease points and check tire pressure.

Preparing Fuel and Engine For Storage

Fuel:

If you have been using "Stabilized Fuel," add stabilized fuel to tank until the tank is full.

NOTE: Filling the fuel tank reduces the amount of air in the fuel tank and helps reduce deterioration of fuel.

If you are not using "Stabilized Fuel:"

1. Park machine safely in a well-ventilated area. (See Parking Safely in the SAFETY section.)

NOTE: Try to anticipate the last time the machine will be used for the season so very little fuel is left in the fuel tank.

2. Turn on engine and allow to run until it runs out of fuel.
3. For machines equipped with key switch, turn key to off position.

IMPORTANT: Stale fuel can produce varnish and plug carburetor or injector components and affect engine performance.

- Add fuel conditioner or stabilizer to fresh fuel before filling tank.
4. Mix fresh fuel and fuel stabilizer in separate container. Follow stabilizer instructions for mixing.
 5. Fill fuel tank with stabilized fuel.
 6. Run engine for a few minutes to allow fuel mixture to circulate through carburetor on gas engine or fuel injectors on diesel engine.

Engine:

Engine storage procedure should be used when vehicle is not to be used for longer than 60 days.

1. Change engine oil and filter while engine is warm.
2. Service air filter if necessary.
3. Clean debris from engine air intake screen.
4. On gas engines:
 - a. Remove spark plugs. Put specified amount of clean engine oil in cylinder(s).

Specification

Engine Oil in Cylinder - Storage — Quantity 30 mL (1 oz)

- b. Install spark plugs, but do not connect spark plug wires.
 - c. Crank the engine five or six times to allow oil to be distributed.
5. Clean the engine and engine compartment.
 6. Remove battery.
 7. Clean the battery and battery posts. Check the electrolyte level, if your battery is not maintenance free.
 8. Close fuel shut-off valve, if your machine is equipped.
 9. Store the battery in a cool, dry place where it will not freeze.

NOTE: The stored battery should be recharged every 90 days.

10. Charge the battery.

IMPORTANT: Prolonged exposure to sunlight could damage the hood surface. Store machine inside or use a cover if stored outside.

11. Store the vehicle in a dry, protected place. If vehicle is stored outside, put a waterproof cover over it.

Removing Machine From Storage

1. Check tire pressure.
2. Check engine oil level.
3. Check battery electrolyte level, if your battery is not maintenance free. Charge battery if necessary.
4. Install battery.
5. On gas engines: Check spark plug gap. Install and tighten plugs to specified torque.
6. Lubricate all grease points.
7. Open fuel shut-off valve, if your machine is equipped.
8. Run the engine 5 minutes without the mower or any attachments running to allow oil to be distributed throughout engine.
9. Be sure all shields and guards or deflectors are in place.

Specifications

Automatic Model D105

Manufacturer	Briggs & Stratton
Model Number	31
Power Rating Information	http://www.briggsandstratton.com/
Displacement	500 cc (30.5 cu. in.)
Spark Plug Gap	0.76 mm (0.030 in.)
Spark Plug Torque20 N·m (15 lb-ft)
Cylinders	Single
Oil Filter	Yes
Air Filter	Cartridge
Transmission	Automatic
Transaxle Model	General Transmission™ RT400
Travel Speed - Forward	0 - 8.9 km/h (0 - 5.5 mph)
Travel Speed - Reverse	0 - 4.8 km/h (0 - 3.0 mph)

Hydrostatic Model D110

Manufacturer	Briggs & Stratton
Model Number	33
Power Rating Information	http://www.briggsandstratton.com/
Displacement	540 cc (33 cu. in.)
Spark Plug Gap	0.76 mm (0.030 in.)
Spark Plug Torque20 N·m (15 lb-ft)
Cylinders	Single
Oil Filter	Yes
Air Filter	Cartridge
Transmission	Hydrostatic
Transaxle Model	TLT200
Travel Speed - Forward	0 - 8.9 km/h (0 - 5.5 mph)
Travel Speed - Reverse	0 - 5.2 km/h (0 - 3.2 mph)

Specifications

Hydrostatic Model D125

Manufacturer	Briggs & Stratton
Model Number	40
Power Rating Information	http://www.briggsandstratton.com/
Displacement	656cc (40 cu. in.)
Spark Plug Gap	0.76 mm (0.030 in.)
Spark Plug Torque	.20 N•m (15 lb-ft)
Cylinders	Twin
Oil Filter	Yes
Air Filter	Cartridge
Transmission	Hydrostatic
Transaxle Model	TLT200
Travel Speed - Forward	.0 - 8.9 km/h (0 - 5.5 mph)
Travel Speed - Reverse	.0 - 5.2 km/h (0 - 3.2 mph)

Hydrostatic Models D130

Manufacturer	Briggs & Stratton
Model Number	44
Power Rating Information	http://www.briggsandstratton.com/
Displacement	724 cc (44.2 cu. in.)
Spark Plug Gap	0.76 mm (0.030 in.)
Spark Plug Torque	.20 N•m (15 lb-ft)
Cylinders	Twin
Oil Filter	Yes
Air Filter	Cartridge
Transmission	Hydrostatic
Transaxle Model	TLT200
Travel Speed - Forward	.0 - 8.9 km/h (0 - 5.5 mph)
Travel Speed - Reverse	.0 - 5.2 km/h (0 - 3.2 mph)

Hydrostatic Models D140

Manufacturer	Briggs & Stratton
Model Number	44
Power Rating Information	http://www.briggsandstratton.com/
Displacement	724 cc (44.2 cu. in.)
Spark Plug Gap	0.76 mm (0.030 in.)
Spark Plug Torque	.20 N•m (15 lb-ft)
Cylinders	Twin
Oil Filter	Yes
Air Filter	Cartridge
Transmission	Hydrostatic
Transaxle Model	Tuff Torq™ T40
Travel Speed - Forward	.0—8.9 km/h (0—5.5 mph)
Travel Speed - Reverse	.0—5.2 km/h (0—3.2 mph)

Hydrostatic Models D155

Manufacturer	Briggs & Stratton
Model Number	44
Power Rating Information	http://www.briggsandstratton.com/
Displacement	724 cc (44.2 cu. in.)

Spark Plug Gap	0.76 mm (0.030 in.)
Spark Plug Torque	.20 N•m (15 lb-ft)
Cylinders	Twin
Oil Filter	Yes
Air Filter	Cartridge
Transmission	Hydrostatic
Transaxle Model	Tuff Torq™ T40
Travel Speed - Forward	.0—8.9 km/h (0—5.5 mph)
Travel Speed - Reverse	.0—5.2 km/h (0—3.2 mph)

Hydrostatic Models D160 and D170

Manufacturer	Briggs & Stratton
Model Number	44
Power Rating Information	http://www.briggsandstratton.com/
Displacement	724 cc (44.2 cu. in.)
Spark Plug Gap	0.76 mm (0.030 in.)
Spark Plug Torque	.20 N•m (15 lb-ft)
Cylinders	Twin
Oil Filter	Yes
Air Filter	Cartridge
Transmission	Hydrostatic
Transaxle Model	Tuff Torq™ HD K46
Travel Speed - Forward	.0 - 8.9 km/h (0 - 5.5 mph)
Travel Speed - Reverse	.0 - 5.2 km/h (0 - 3.2 mph)

Electrical System

Charging System	Regulated Circuit
Charging System Capacity (D105, D110, D125, D130, D140)	9 Amp
Charging System Capacity (D155, D160, D170)	16 Amp
Battery Voltage	12 Volts
Battery Type	BCI Group U1

Capacities

Models D105, D110	
Crankcase, with Oil Filter	1.4 L (1.5 qt)
Models D125, D130, D140, D155, D160, D170	
Crankcase, with Oil Filter	1.9 L (2.0 qt)
Fuel Tank (All Models)	9 L (2.4 gal)

Fuel System (All Models)

Fuel Types (Recommended):	
	Regular Grade 87 Octane Unleaded Fuel
	Ethanol Blended Fuel (Up to 10%)
	MTBE Reformulated Fuel (Up to 15%)

Recommended Lubricants

Engine Oil	TURF-GARD® OR PLUS-4®
Grease	GREASE-GARD™ Premium Plus

Warranty

..... John Deere Multi-Purpose HD Lithium Complex Grease
™ GREASE-GARD is a trademark of Deere & Company

(Specifications and design subject to change without notice.)

Dimensions

Height (D105, D110)	108 cm (42.5 in.)
Height (D125, D130, D140)	113 cm (45.5 in.)
Height (D155)	118 cm (46.46 in.)
Height (D160, D170)	118 cm (46.5 in.)
Length (Overall) (D105, D110, D125)	175 cm (68.75 in.)
Length (Overall) (D130)	186 cm (73.25 in.)
Length (Overall) (D140)	177 cm (69.5 in.)
Length (Overall) (D155)	191 cm (75.2 in.)
Length (Overall) (D160, D170)	194 cm (76.5 in.)
Width (Mower Deck Chute Down) (D105, D110, D125, D130)	138 cm (54.4 in.)
Width (Mower Deck Chute Down) (D155)	155 cm (61 in.)
Width (Mower Deck Chute Down) (D140, D160)	152 cm (60 in.)
Width (Mower Deck Chute Down) (D170)	174 cm (68.5 in.)
Weight: D105	189 kg (415 lb)
Weight: D110	193 kg (423 lb)
Weight: D125	198 kg (436 lb)
Weight: D130	201 kg (443 lb)
Weight: D140	218 kg (479 lb)
Weight: D155	217.72 kg (480 lb)
Weight: D160	229 kg (504 lb)
Weight: D170	241 kg (530 lb)

Tires

Models D105, D110, D125	
Size (Front)	15 x 6.00 - 6
Size (Rear)	20 x 8.0 - 8
Tire Pressure (Front)	.97 kPa (14 psi)
Tire Pressure (Rear)	.69 kPa (10 psi)
Models D130, D140, D155	
Size (Front)	15 x 6.00 - 6
Size (Rear)	20 x 10.0 - 8
Tire Pressure (Front)	.97 kPa (14 psi)
Tire Pressure (Rear)	.69 kPa (10 psi)
Models D160, D170	
Size (Front)	16 x 6.5 - 8
Size (Rear)	22 x 9.5 - 12
Tire Pressure (Front)	.83 kPa (12 psi)
Tire Pressure (Rear)	.83 kPa (12 psi)

(Tire pressure information is also located on the sidewalls of the tires)

Mower Deck - 107 cm (42 in.)

Blades Rotary	2
Blade Nut Torque (w/5/8 in. Nut)	.88 N•m (65 lb-ft)
Cutting Height (Approximately)	.25 -102 mm (1 - 4 in.)

Cutting Width..... 1067 mm (42 in.)

Mower Deck - 122 cm (48 in.)

Blades Rotary	3
Blade Nut Torque (w/5/8 in. Nut)	.88 N•m (65 lb-ft)
Cutting Height (Approximately)	.25 -102 mm (1 - 4 in.)
Cutting Width	1219 mm (48 in.)

Mower Deck - 137 cm (54 in.)

Blades Rotary	3
Blade Nut Torque (w/5/8 in. Nut)	.88 N•m (65 lb-ft)
Cutting Height (Approximately)	.25 -102 mm (1 - 4 in.)
Cutting Width	1371 mm (54 in.)

Warranty

Warranty

Product Warranty

Product warranty is provided as part of John Deere's support program for customers who operate and maintain their equipment as described in this manual.

Engine related warranties stated in this manual refer only to emissions-related parts and components of your engine. The complete engine warranty, less emission-related parts and components, is provided separately as the "Limited Warranty for New John Deere Equipment".

California and U.S. EPA Emissions Control System Warranty Statement (Off-Road Gas Engines)

Your Warranty Rights and Obligations

The California Air Resources Board, John Deere, and the United States Environmental Protection Agency are pleased to explain the emissions control system's warranty on your model year 2015 or 2016 spark ignited off-road engine equipment. In California, new equipment that uses small or large (less than 1 liter) spark ignited off-road engines must be designed, built and equipped to meet the State's stringent anti-smog standards. John Deere must warrant the emissions control system on your spark ignited off-road engine equipment for the period listed below provided there has been no abuse, neglect or improper maintenance of your equipment.

Your emissions control system may include parts such as: carburetors or fuel-injection system, ignition system, catalytic converters, fuel tanks, valves, filters, clamps, connectors, and other associated components. Also included may be hoses, belts, sensors and other emission-related assemblies.

Where a warrantable condition exists, John Deere will repair your spark ignited off-road engine equipment at no cost to you including diagnosis, parts and labor.

Manufacturer's Warranty Coverage

This emissions control system is warranted for two years. If any emissions related part on your equipment is defective, the part will be repaired or replaced by John Deere.

Owner's Warranty Responsibilities

- As the spark ignited off-road engine equipment owner, you are responsible for the performance of the required maintenance listed in your Operator's Manual. John Deere recommends that you retain

Warranty

all receipts covering maintenance on your spark ignited off-road engine equipment, but John Deere cannot deny warranty solely for lack of receipts or for your failure to ensure the performance of all scheduled maintenance.

- As the spark ignited off-road engine equipment owner, you should however be aware that John Deere may deny you warranty coverage if your spark ignited off-road engine equipment or a part has failed due to abuse, neglect, or improper maintenance or unapproved modifications.
- You are responsible for presenting your spark ignited off-road engine equipment to a John Deere Turf and Utility distribution center or service center as soon as a problem exists. The warranty repairs should be completed in a reasonable amount of time, not to exceed 30 days. If you have a question regarding your warranty coverage, you should contact your John Deere Turf and Utility retailer, or the John Deere Customer Contact Center at 1- 800-537-8233, or e-mail John Deere from www.Deere.com.

General Emissions Warranty Coverage

The warranty period begins on the date the equipment is delivered to an ultimate purchaser. John Deere warrants to the ultimate purchaser and each subsequent purchaser that the spark ignited off-road engine equipment is:

- Designed, built and equipped so as to conform to all applicable regulations adopted by the California Air Resources Board;
- Designed, built and equipped so as to conform at the time of sale with applicable U.S. Environmental Protection Agency regulations under 40 CFR Parts 1054 and 1060: and,
- Free from defects in materials and workmanship which cause such engine to fail to conform with applicable regulations for a period of two years of engine use from the date of sale to the ultimate purchaser.

Emissions Warranty Interpretation

- Any warranted part that is not scheduled for replacement as required by the maintenance instructions in the Operator's Manual is warranted for two years. If any such part fails during the period of warranty coverage it will be repaired or replaced by John Deere. Any such part repaired or replaced under warranty is warranted for the remaining warranty period.
- Any warranted part that is scheduled only for regular inspection in the maintenance instructions in the Operator's Manual is warranted for two years. A statement in the Operator's Manual to the effect of "repair or replace as necessary" does not reduce the period of warranty coverage. Any such part repaired or replaced under warranty is warranted for the remaining warranty period.
- Any warranted part that is scheduled for replacement as required maintenance in the Operator's Manual is warranted for the period of time prior to the first scheduled replacement point for that part. If the part fails prior to the first scheduled replacement, the part will be repaired or replaced by John Deere. Any such part repaired or replaced under warranty is warranted for the remainder of the period prior to the first scheduled replacement point for the part.
- Repair or replacement of any warranted part under the warranty will be performed at no charge to the owner at any authorized John Deere Turf and Utility retailer.
- The owner will not be charged for diagnostic labor which leads to the determination that a warranted part is defective, provided such work is performed by John Deere.
- John Deere will repair damages to other engine components proximately caused by a failure under warranty of any emissions-related warranted part.
- Add-on or modified parts that are not exempted by the California Air Resources Board may not be used. The use of any non-exempted add-on or modified parts will be grounds for disallowing a warranty claim. John Deere will not be liable to warrant failures of warranted parts caused by the use of a non-exempted add-on or modified part.

Emission Warranty Parts List

Coverage under this warranty extends only to the parts listed below (the emissions control system parts) to the extent these parts were on the engine and equipment purchased.

Fuel Metering System:

- Carburetor and internal parts (or fuel injection system)
- Air/fuel ratio feedback and control system
- Cold start enrichment system

Evaporative System:

- Fuel tank, fuel cap and tether
- Fuel hose, line, fittings, clamps
- Fuel pump, fuel shut-off valve
- Fuel vapor hoses, fittings
- Carbon canister
- Rollover/slant valve for fuel vapor control
- Purge and vent line

Air Induction System:

- Air cleaner
- Intake manifold

Ignition System:

- Spark plugs
- Magneto or electronic ignition system
- Spark advance/retard system

Exhaust System:

- Exhaust manifold
- Catalyst muffler

Miscellaneous Items Used in Above Systems

- Valves and Switches: vacuum, temperature, position, check, time-sensitive
- Electronic controls
- Hoses, belts, connectors and assemblies

Limited Liability

a) The liability of John Deere under this Emissions Control System Warranty is limited solely to the remedying of defects in materials or workmanship. This warranty does not cover inconvenience or loss of use of the non-road equipment or engine or transportation of the equipment or engine to or from the John Deere Turf and Utility retailer. John Deere shall not be liable for any other expense, loss, or damage, whether direct, incidental, consequential (except as listed above under "coverage") or exemplary arising in connection with the sale or use of or inability to use the non-road equipment or engine for any other purpose.

b) No express emissions control system warranty is given by John Deere with respect to the equipment or engine except as specifically set forth in this document. Any emissions control system warranty implied by law, including any warranty of merchantability or fitness for a particular purpose, is expressly limited to the emissions control system warranty terms set forth in this document.

c) No dealer is authorized to modify this Federal, California and John Deere Emissions Control System Warranty.

Tire Warranty

John Deere warranty applies for tires available through the John Deere parts system. For tires not available through the John Deere parts system, the tire manufacturer's warranty applicable to your machine may not apply outside the U.S. (See your John Deere dealer for specific information.)

Getting Quality Service

Limited Battery Warranty For Factory Installed Batteries

NOTE: Applicable in North America only. For complete machine warranty, reference a copy of the John Deere warranty statement. Contact your John Deere dealer to obtain a copy.

TO SECURE WARRANTY SERVICE

The purchaser must request warranty service from a John Deere dealer authorized to sell John Deere batteries, and present the battery to the dealer with the top cover plate codes intact.

FREE REPLACEMENT PERIOD

Any new battery which becomes unserviceable (not merely discharged) due to defects in material or workmanship within the FREE REPLACEMENT PERIOD will be replaced free of charge. Installation costs will be covered by warranty if the unserviceable battery was installed by a John Deere factory or dealer and the replacement battery is installed by a John Deere dealer.

PRO RATA ADJUSTMENT (batteries with letter code identification only)

Any new battery which becomes unserviceable (not merely discharged) due to defects in material or workmanship within the Pro Rata Warranty Period will be replaced upon payment of the battery's current list price less a pro rata credit for unused months of service. The applicable adjustment period is determined from the Warranty Code printed at the top of the battery and table below. Installation costs are not covered after the battery warranty period has ended.

THIS WARRANTY DOES NOT COVER

- A. Breakage of the container, cover, or terminals.
- B. Depreciation or damage caused by lack of reasonable and necessary maintenance or by improper maintenance.
- C. Transportation, mailing, or service call charges for warranty service.
- D. Batteries that are merely discharged.

LIMITATION OF IMPLIED WARRANTIES AND PURCHASER'S REMEDIES

To the extent permitted by law, neither John Deere nor any company affiliated with it makes any warranties, representations, or promises as to the quality, performance or freedom from defect of the products covered by this warranty. IMPLIED WARRANTIES OF MERCHANTABILITY AND FITNESS FOR A PARTICULAR PURPOSE, TO THE EXTENT APPLICABLE, SHALL BE LIMITED IN DURATION TO THE APPLICABLE ADJUSTMENT PERIOD SET FORTH HERE. THE PURCHASER'S ONLY REMEDIES IN CONNECTION WITH THE BREACH OR PERFORMANCE OF ANY WARRANTY ON JOHN DEERE BATTERIES ARE THOSE SET FORTH HERE. IN NO EVENT WILL THE DEALER, JOHN DEERE OR ANY COMPANY AFFILIATED WITH JOHN DEERE BE LIABLE FOR INCIDENTAL OR CONSEQUENTIAL DAMAGES. (Note: Some states do not allow limitations on how long an implied warranty lasts or the exclusion or limitation of incidental or consequential damages. So these limitations and exclusions may not apply to you.) This warranty gives you specific legal rights, and you may also have some rights which vary from state to state.

NO DEALER WARRANTY

The selling dealer makes no warranty of its own and the dealer has no authority to make any representation or promise on behalf of John Deere, or to modify the terms or limitations of this warranty in any way.

WARRANTY TERMS TABLE

NOTE: If your battery is not labeled with a warranty code, it is a warranty code 6.

Warranty Code	Free Replacement Period	Pro Rata Warranty Period
A	90 Days	40 Months
B	90 Days	36 Months
C	90 Days	24 Months
D	12 Months	48 Months
E	90 Days	12 Months
F	90 Days	60 Months
G	12 Months	60 Months
H	12 Months	60 Months
6	6 Months	0 Months
12	12 Months	0 Months
18	18 Months	0 Months

The RSX850i original equipment battery will carry a 100% Full Replacement for the duration of the complete machine warranty.

Getting Quality Service

Service Literature

If you would like a copy of the Parts Catalog or Technical Manual for this machine call:

- **U.S. & Canada:** 1-800-522-7448.
- **All Other Regions:** Your John Deere dealer.

Parts

We recommend John Deere quality parts and lubricants, available at your John Deere dealer.

When you order parts, your John Deere dealer needs the serial number or product identification number (PIN) for your machine or attachment. These are the numbers that you recorded in the Product Identification section of this manual.

Order Service Parts Online

Visit <http://JDParts.deere.com> for your Internet connection to parts ordering and information.

John Deere Quality Continues with Quality Service

John Deere provides a process to handle your questions or problems, should they arise, to ensure that product quality continues with your John Deere dealer's parts and service support.

Follow the steps below to get answers to any questions you may have about your product.

1. Refer to the appropriate attachment, machine or equipment operator manuals.
2. Contact your John Deere dealer with unanswered questions.
3. In North America or Canada, call the John Deere Customer Contact Center.
 - Call 1-800-537-8233 and provide product serial number and model number.

Service Record

Service Record

Record Service Dates

Oil Change	Oil Filter Change (If Equipped)	Lubricate Machine	Air Cleaner Element Check/Clean	Fuel Filter Change

Slope Gauge

Slope Gauge

Slope Gauge

Slope Gauge Template

NOTE: Cut along left boundary line of graphic as a guide to remove template.

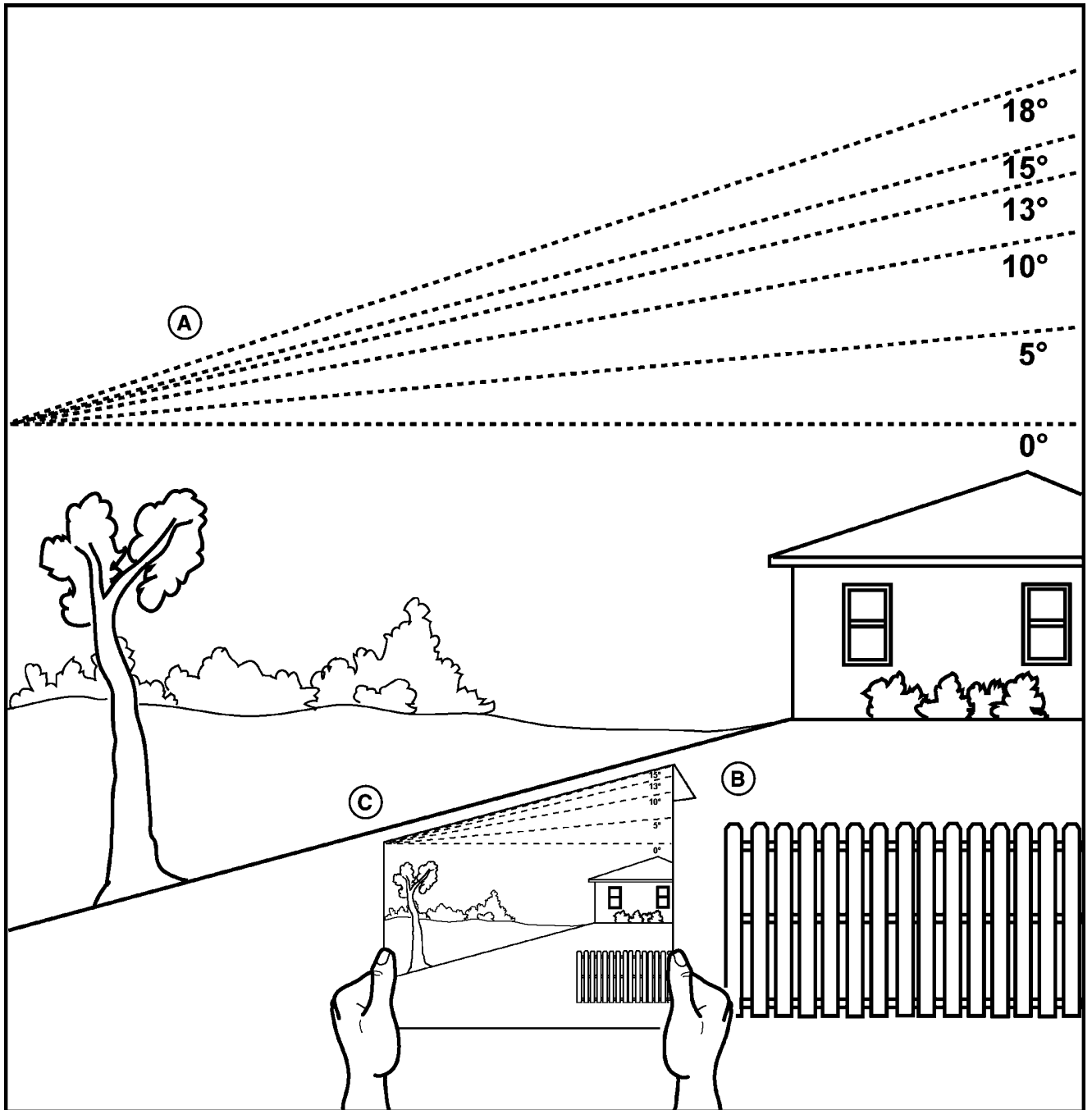

MXT007077—UN—11JUN13

Use this slope gauge to determine if a slope is too steep for safe operation. Do not operate your machine on a slope greater than what is recommended in your Operator's Manual. See Operating on Slopes in the Safety Section.

- Fold along the appropriate line (A) to match the recommended slope.
- Align this edge (B) with a vertical surface, a tree, building, fence pole, etc.
- Compare slope (C) with folded edge.

Slope Gauge

Index

A			
Accessories, using32	
Air cleaner elements (D105 and D110), checking and cleaning36	
Air cleaner elements (D125, D130 and D140), checking and cleaning37	
Air cleaner elements (D160, D170), checking and cleaning37	
Attachment engagement switch or lever, testing26	
Axle, lubricating front34	
B			
Battery and Terminals, Cleaning45	
Battery, charge and connect at assembly18	
Battery, removing and installing45	
Battery, Service Safely45	
Battery, Using Booster46	
Belt, replacing mower drive (54 in. (137 cm) and 54 in. (137 cm) Decks)42	
Belt, replacing mower drive (107 cm (42 in.) mower deck)42	
Blades, balancing44	
Blades, Checking Mower43	
Blades, servicing mower44	
Blades, sharpening44	
Brake, using park26	
Bulb, replacing headlight46	
C			
Canadian electromagnetic compatibility (EMC) compliance7	
Carburetor, Adjusting39	
Cleaning, Machine16	
Controls on automatic transmission, using travel28	
Controls on hydrostatic transmission, using travel28	
Cruise control, using29	
Cutting height, adjusting23	
D			
Deck, adjusting mower level23	
Deck, installing mower41	
Deck, removing mower40	
E			
Electrical troubleshooting51	
Emission filter, checking and cleaning38	
Engagement clutch, break in electric18	
Engine fins, cleaning36	
Engine, idling27	
Engine, starting27	
Engine, stopping28	
Engine troubleshooting50	
F			
Filter, changing engine oil35	
Fuel and Stabilizer, Using Proper47	
Fuel filter, replacing39	
Fuel Safety15	
Fuel storage52	
Fuel Tank, Filling47	
Fuse, replacing46	
G			
Grease33	
H			
Headlights, using27	
Hood, removing and installing48	
Hourmeter, using26	
I			
Identification numbers3	
Intervals for Service33	
L			
Label, certification7	
Labels, safety (no text)8	
Labels, safety (text)5	
Lifting machine47	
M			
Material Collection System, Unplugging30	
Metal Surfaces, Repairing and Cleaning48	
Moving machine by hand30	
Mower blades, choosing32	
Mower deck, adjusting belt tension (107 cm (42 in.) deck)43	
Mower deck, adjusting spindle brakes (107 cm (42 in.) deck)43	
Mower deck, cleaning30	
Mower deck, engaging and disengaging29	
Mower deck, lubricating pivot points34	
Mower deck, removing and installing drive belt at engine sheave (122 cm (48 in.) and 137 cm (54 in.) decks)39	
Mower troubleshooting51	
Mowing tips32	
O			
Oil, Engine34	
Oil level, checking engine35	
Operating checklist, daily22	
Operating safely10	
Operator station controls (D105)20	
Operator station controls (D110, D125, D130)21	
Operator station controls (D140, D160, D170)22	
P			
Park Brake, Testing26	
Parts, Replacement56	
Plastic And Painted Surfaces, Avoid Damage To22	
Plastic surfaces, cleaning48	
R			
Record service dates57	
Reverse implement option, testing26	
Reverse implement option, using the29	
S			
Safety Systems, Testing25	
Safety, Tire15	
Seat, adjusting22	
Slopes, operating on12	
Spark Arrestor, Using11	
Spark plug, checking38	
Storage, Preparing Machine for51	
Storage, Removing Machine from52	
Storing Safety51	
Switch, Testing Park Brake25	
Switch, Testing Seat26	
T			
Technical Manual56	
Template, slope gauge59	
Tire chains, using32	
Tire Pressure, Checking48	
Tractor troubleshooting51	
Transmission, Checking Z225 and Z245 (See your John Deere dealer)39	
Transporting machine on trailer31	
Troubleshooting Chart50	
W			
Warranty Maintenance Statement, Engine34	

Index

Warranty Registration	4
Weights, using	32
Wheel Assembly, Removing and Installing Front	49
Wheel Assembly, Removing and Installing Rear	49
Wheels, adjusting mower deck	25

Notes

Notes
