

INSTRUCTION FOR USE



**PH050010/PH050011/PH050012/PH050013
PH050014/PH050015/PH050017/PH050018
INFLATABLE SPA**



QUESTIONS??

DO NOT CONTACT YOUR RETAILER, CONTACT OUR SPA EXPERTS AT 800-279-1906 OR EMAIL AT SERVICE@FIRSTSPAUSA.COM

IMPORTANT SAFETY INSTRUCTIONS

- WARNING1: The Spa should be supplied through a residual current device (GFCI) with a rated tripping current not exceeding 20 AMPS.
- WARNING2: Electric installations should fulfill the requirements of local standards. Grounded Spas must be permanently connected to fixed wiring
- WARNING3: If the supply cord is damaged, it must be replaced by the manufacturer or its service agent or a similarly qualified person in order to avoid a hazard. Replace damage cord immediately.
- WARNING4: Parts containing live parts, except parts supplied with safety extra-low voltage not exceeding 12 V, must be inaccessible to a person in the spa.
- WARNING5: To reduce the risk of electric shock, do not use a extension cord to connect unit to electric supply; provide a properly located receptacle.
- WARNING6: Parts incorporating electrical components, except for remote control devices, must be located or fixed so that they cannot fall into the spa.
- WARNING7: To avoid electric shock, do not use the spa when it is raining.
- WARNING8: Never operate the spa if the suction fittings are broken or missing. Never replace a suction fitting with one rated less than the flow rate marked on the original suction fitting.
- WARNING9: To reduce the risk of injury, do not permit children to use this product unless they are closely supervised at all times.
- WARNING10: Water attracts children. Always have the spa cover locked after each use.
- WARNING11: When the jet function is going to be used, make sure the cover of the spa is opened first.
- WARNING12: If there is any possibility that the water in the spa is frozen, do not sitch the spa on.
- WARNING13: Risk of electric shock. Never operate any electrical Spa when in the spa or when your body is wet. Never place any electric Spa, such as a light, telephone, radio, or television, within 5 feet (1.5m)of a spa.
- WARNING14: Pets should be kept away from spa to avoid damage.
- WARNING15: Risk of electric shock. Install the spa at least 5 feet (1.5m) from all metal surfaces. As an alternative, a spa may be installed within 5 feet of metal surfaces if each metal surface is permanently connected by a minimum 1.0 mm² solid copper conductor to the wire connector on the terminal box that is provided for this purpose.
- WARNING16: Risk of accidental drowning. Extreme caution must be exercised to prevent unauthorized access by children. To avoid accidents, ensure that children cannot use this spa unless they are supervised at all times.
- WARNING17: During pregnancy, soaking in hot water may cause damage to the unborn fetus. Limit use to 10 minutes at a time.
- WARNING18: The use of alcohol, drugs, or medication before or during the spa use may lead to unconsciousness with the possibility of drowning.
- WARNING19: Obese persons and persons with a history of heart disease, low or high blood pressure, circulatory system problems, or diabetes should consult a physician before using a spa ...
- CAUTION1: To avoid damage to the pump, the spa must never be operated unless the spa is filled with water.
- CAUTION2: Immediately leave spa if uncomfortable or sleepy.

- CAUTION3: Place only on surface that can withstand the floor loading requirement of your spa.
- CAUTION4: The spa should not be setup or left out in temperatures lower than 4°C (40°F).
- CAUTION5: Only add chemicals once the spa is filled with water and only as needed.
- CAUTION 6: In order to avoid a hazard due to inadvertent resetting of the thermal cutout, this spa must not be supplied through an external switching device, such as a timer, or connected to a circuit that is regularly switched on and off by the utility.
- CAUTION 7 : THIS SPA CAN BE USED BY CHILDREN AGED FROM 8 YEARS AND ABOVE AND PERSONS WITH REDUCED PHYSICAL, SENSORY OR MENTAL CAPABILITIES OR LACK OF EXPERIENCE AND KNOWLEDGE IF THEY HAVE BEEN GIVEN SUPERVISION OR INSTRUCTION CONCERNING USE OF THE SPA IN A SAFE WAY AND UNDERSTAND THE HAZARDS INVOLVED. CHILDREN SHALL NOT PLAY WITH THE SPA. CLEANING AND USER MAINTENANCE SHALL NOT BE MADE BY CHILDREN WITHOUT SUPERVISION
- CAUTION 8: The spa should not be setup or left out in temperatures lower than 4°C (40°F)

SAVE THESE INSTRUCTIONS

INSTALLATION INSTRUCTION

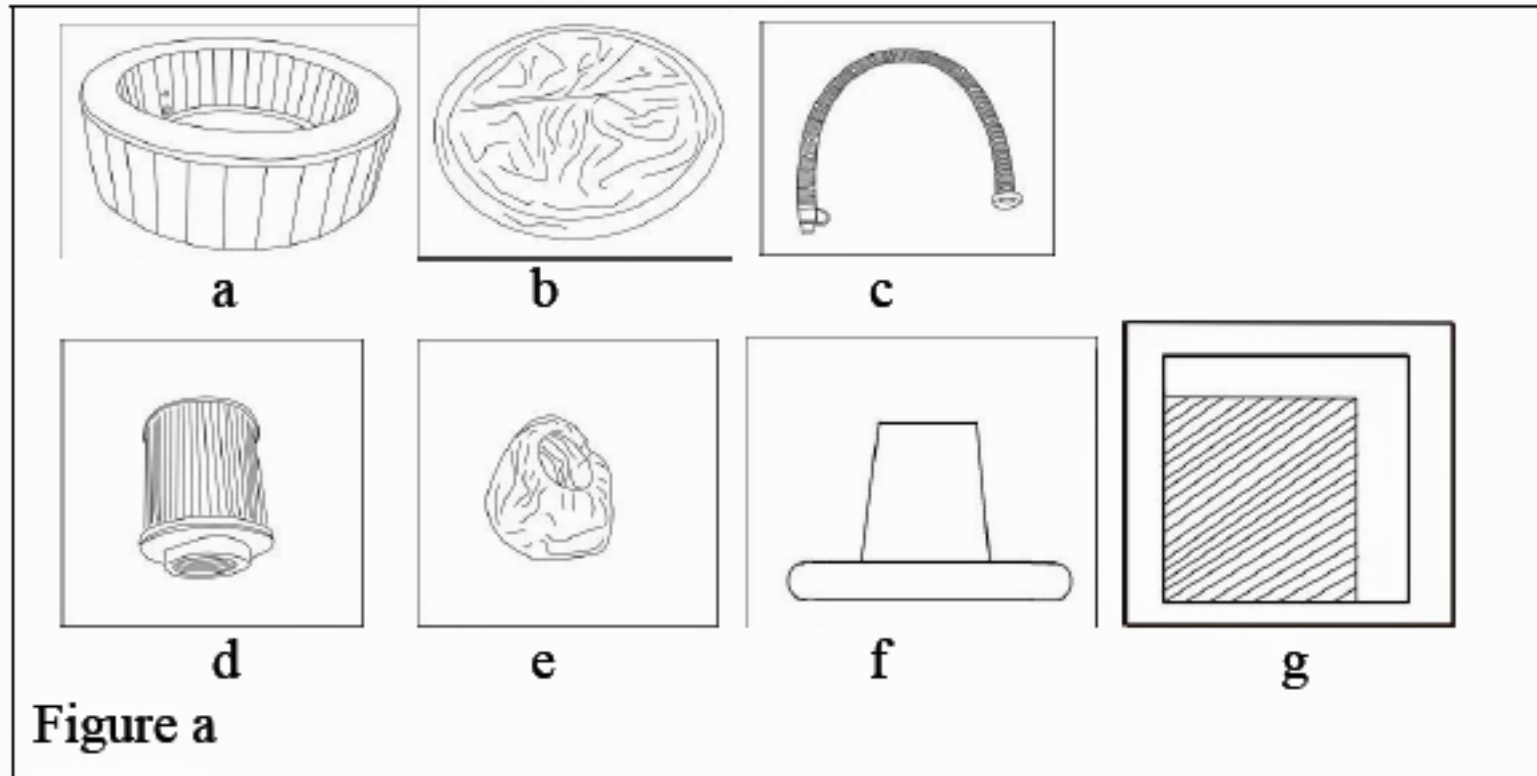

ENSURE TO CHECK ALL PARTS ARE PRESENT:

- a. Spa
- b. PU cover with foil and zipper
- c. Inflation hose
- d. Filter cartridge
- e. Filter cartridge cover
- f. Rubber plug
- g. Repair kit

SITE REQUIREMENTS:

WARNING1: The floor has to be capable of supporting the expected load.

WARNING2: An adequate drainage system has to be provided to deal with overflow water.

IMPORTANT: Because of the combined weight of the spa, water, and users, it is extremely important that the surface where the spa is installed is smooth, flat, level and capable of uniformly supporting this weight for the entire time the spa is installed. If the spa is placed on a surface, which does not meet these requirements, any damage caused by

INDOORS INSTALLATION:

Be aware of special requirements if you install the spa indoors.

1. The floor must be able to withstand the capacity of the spa. The floor should be a non-slip, level surface.
2. Proper drainage is essential for indoor spa installation. When building a new room for the spa it is recommended that a floor drain be installed.
3. Humidity is a natural side effect of spa installation. Determine the effects of airborne moisture on exposed wood, paper, etc. in the proposed location. To minimize these effects it is best to provide plenty of ventilation to the selected area. An architect can help determine if more ventilation is needed.

NOTE: Do not install the spa on carpet or other material that can be damaged by moisture.

OUTDOORS INSTALLATION:

1. No matter where you install the spa, it is important you have a solid support foundation. If you are installing the spa outdoors, ensure there are no sharp objects that could damage it and that the location is level so the spa sits stably and properly.
2. During filling, emptying or when in use, water may spill out of the spa. The spa should be installed near a ground drain.
3. Do not leave the spa's surface exposed to direct sunlight for long periods of time.

ASSEMBLY

1. Unfold the spa from the packaging. Spread the spa and cover out. Make sure both are right side up.

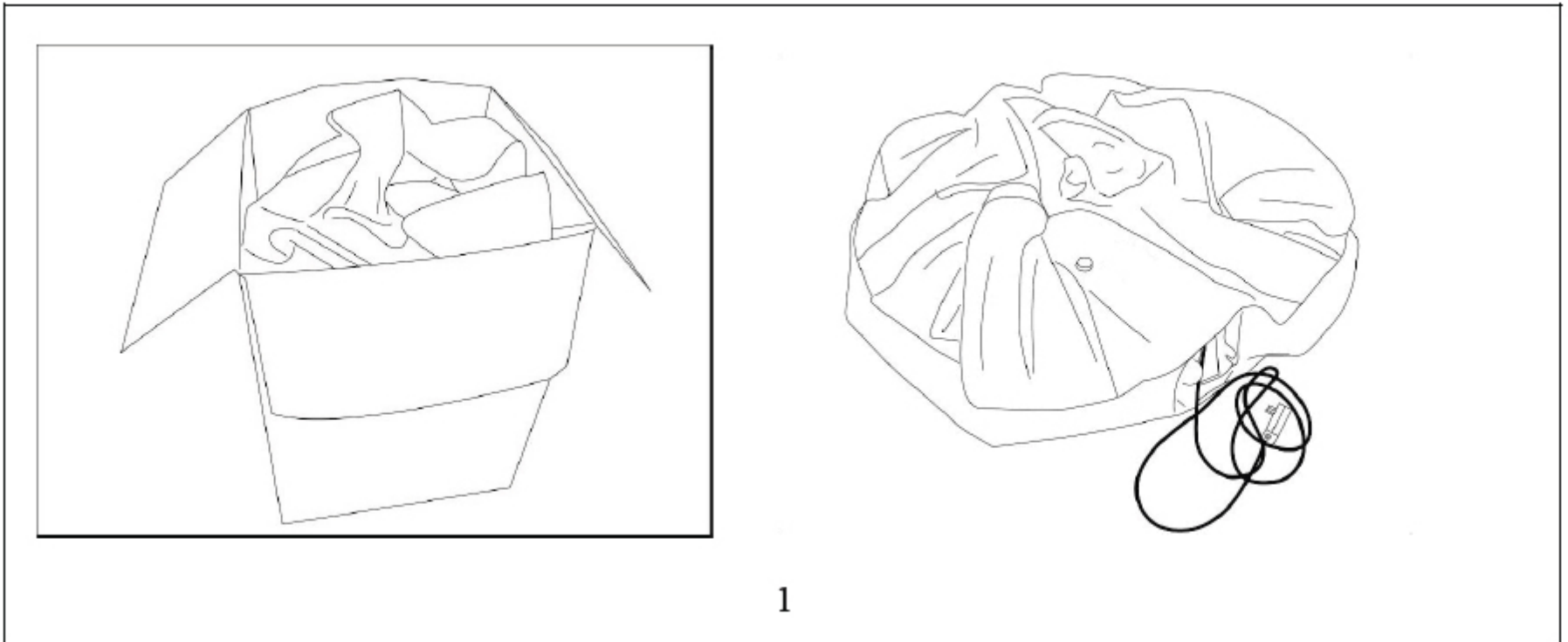

2. Open the air outlet on the spa. Screw one end of the inflation hose onto it.
3. Open the air valve on the equipment control unit. Connect the other end of inflation hose into the valve.

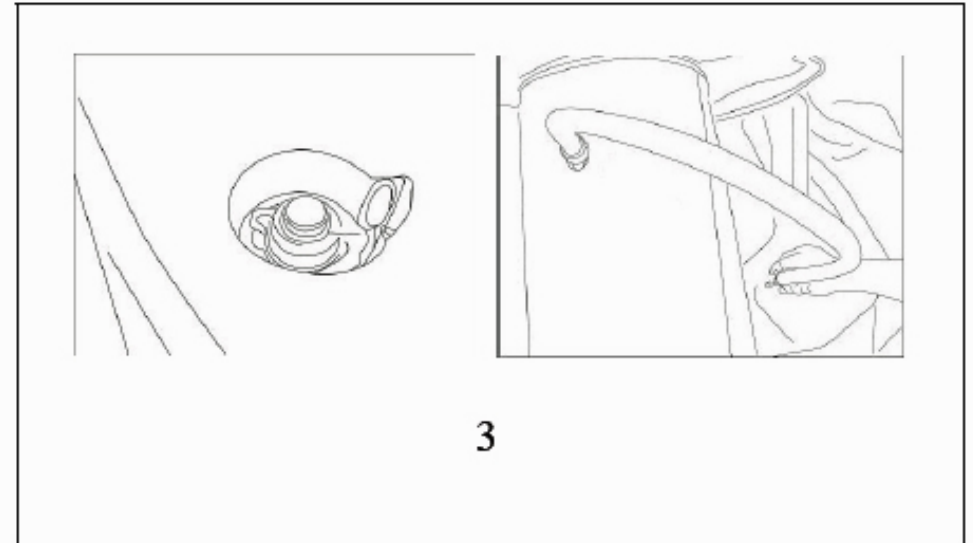
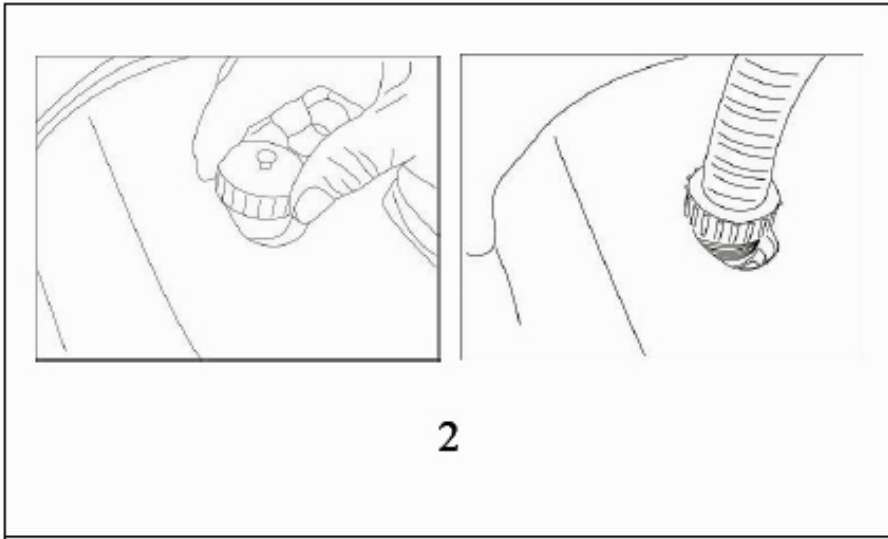

4. Inflate the spa tub by pressing the Jet “Bubble” button.

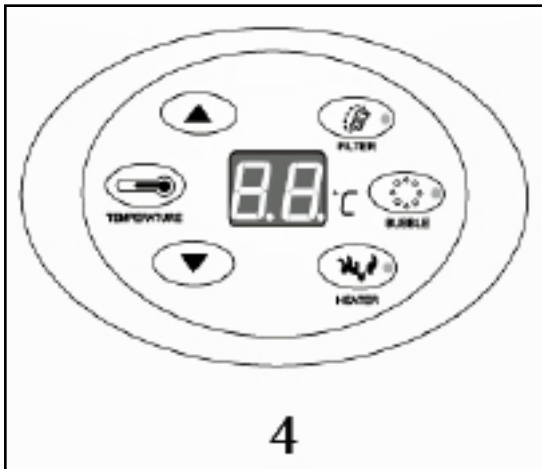

When the spa is properly inflated, press the “Bubble” button to shut off the bubbles.

Attention 1: Do not over inflate.

Attention 2: If you want inflation when the spa has filled water, you must put on the Jets 2-3 minutes by pressing the “Bubble” button first, and then follow according to step 2-5 above.

5. Remove the inflation hose and screw the valve tight.

6. Remove the inflation hose from the air outlet and screw the nut tight.

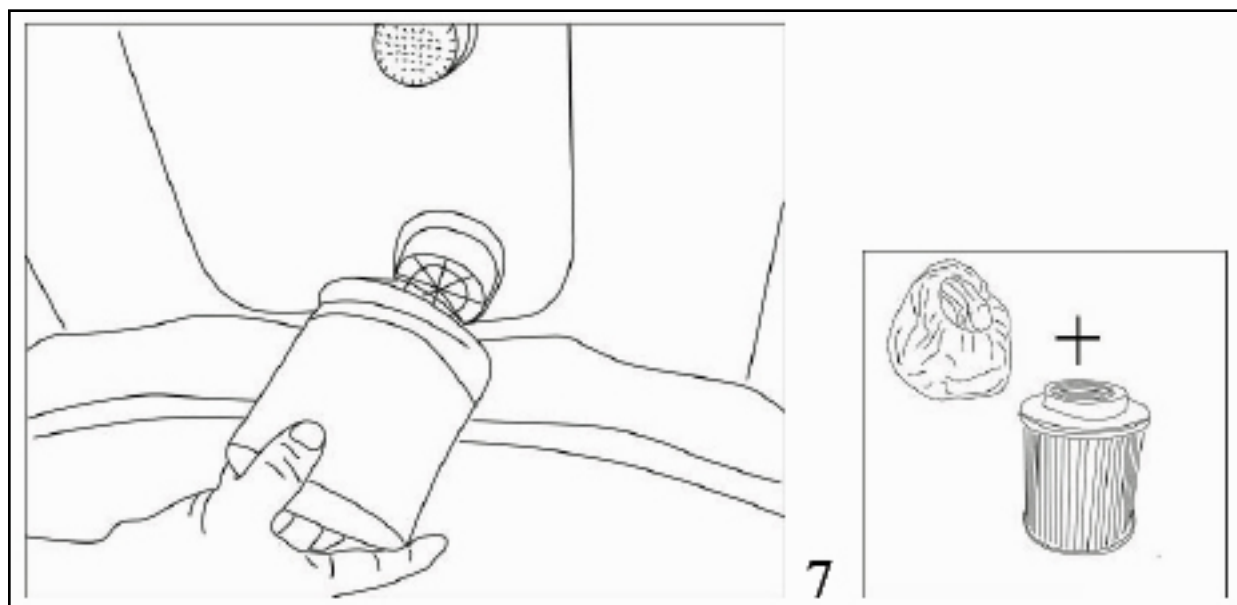

7. Screw the filter cartridge onto the water inlet on the spa wall by turning it clockwise.
8. Use a garden hose to fill the spa with water to the water level printed on the spa wall.
9. Place the cover onto the spa, fasten the zipper.

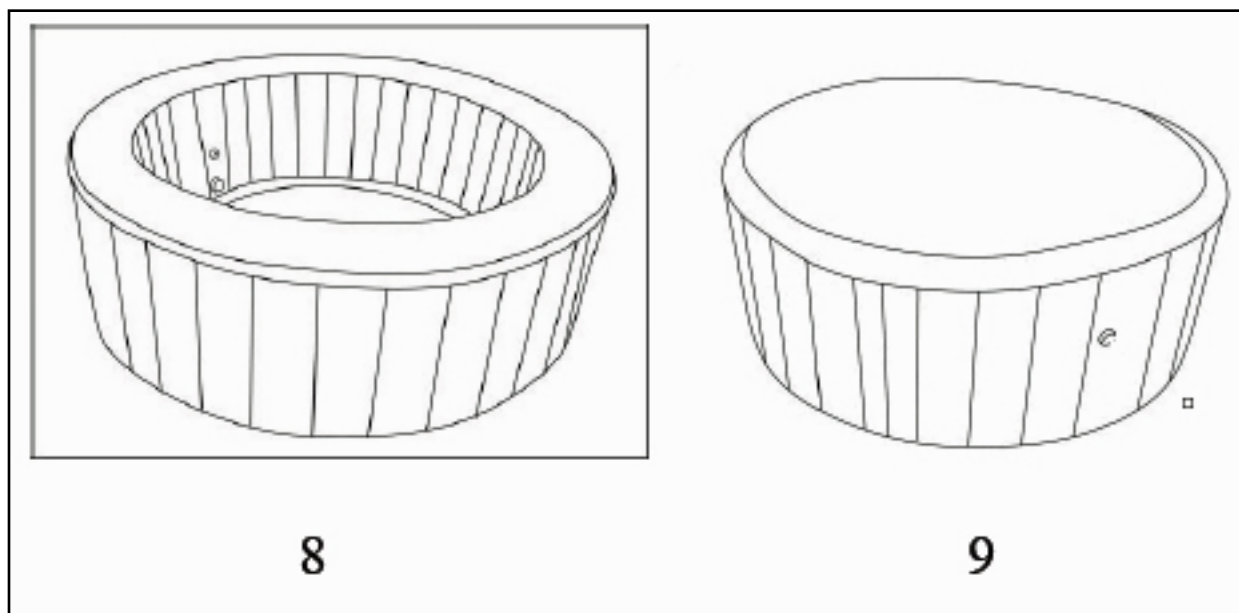

OPERATION

You must insure the water in the spa matches the water line printed on the spa wall. Never dry-run the power pack as such type of operation will void the warranty.

CONTROL PANEL



FILTER

FILTER BUTTON - On-off button for the filtration system. Press this button, and the filter pump will turn on and the button red indicator light will turn on. Press again, the pump will stop working and the light will turn off.

NOTE: If you have used the spa for 168 hours, the letters 'FC' will appear on the display screen, accompanied by a warning tone. This is an automatic filter replacement reminder. (Please refer to page the Maintaining Section)

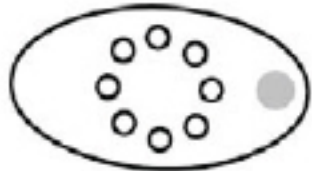

BUBBLE

BUBBLE BUTTON - On-off button for the jet system. Press this button and the air pump will start working and the red indicator light will be on. Press again and the jet system will stop working and the light will be off. The jet system will stop automatically after working for 20 minutes. If there is still a need, you have to wait for 10 minutes and then press the "Bubble" button again. During the time period which the jet function has been on for less than 15 minutes, bubbling can be stopped or started. During the time period that the jet function has been on for more than 15 minutes, bubbling can be stopped but not be re-started. The re-starting of jets should wait for 10 minutes. When the jets have been on for 20 minutes and have stopped, the function cannot be started again within 10 minutes.



HEATER

HEATER BUTTON - On-off button for the heating system. When the HEATER button has been pressed, the heating system will start working and the red indicator light will turn on. At the same time, the red indicator light of the FILTER button will also be on and the filter pump will start working, also. This is a normal phenomenon required by the design. When the preset temperature has been reached, the heating system will stop working while the heating indicator light will remain on. The filter pump will stop working and the filtration indicator light will also be off. When the water temperature falls to 2 degrees below the preset temperature, the heating system will start working automatically and so will the filter pump. To turn the heater function off manually, just press the heating button again.



TEMPERATURE

TEMPERATURE BUTTON – Button for setting temperature. Press this button and the numbers on the display screen will start flashing, the buttons for increasing or decreasing temperatures can be pressed to set the temperature. When settings are finished, press the TEMPERATURE BUTTON again to confirm. Default temperature is 104°F, and temperature can be set in the range of 68-104°F.

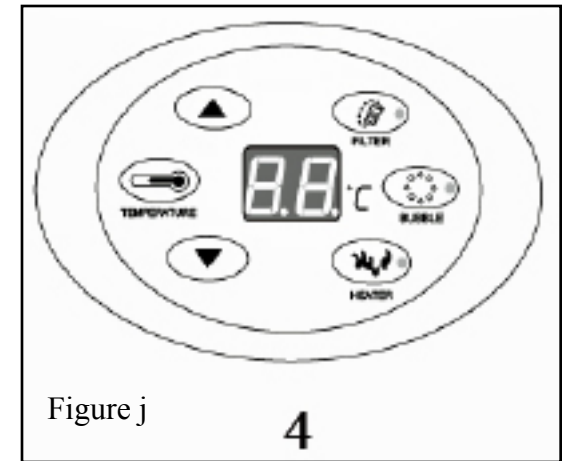

Figure j

4



--- Button for increasing temperature



--- Button for decreasing temperature

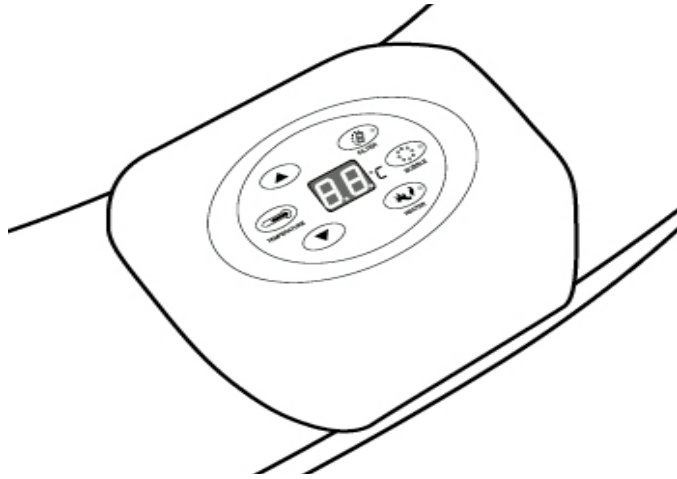

Base of the topside control panel is made of environmental-friendly PU material that is soft and comfortable. Surface of the base can be washed.
The topside control panel is chrome-plated, which meets ROHS standards. Surface films are glued to the panel by marine glue.

BODY OF SPA:

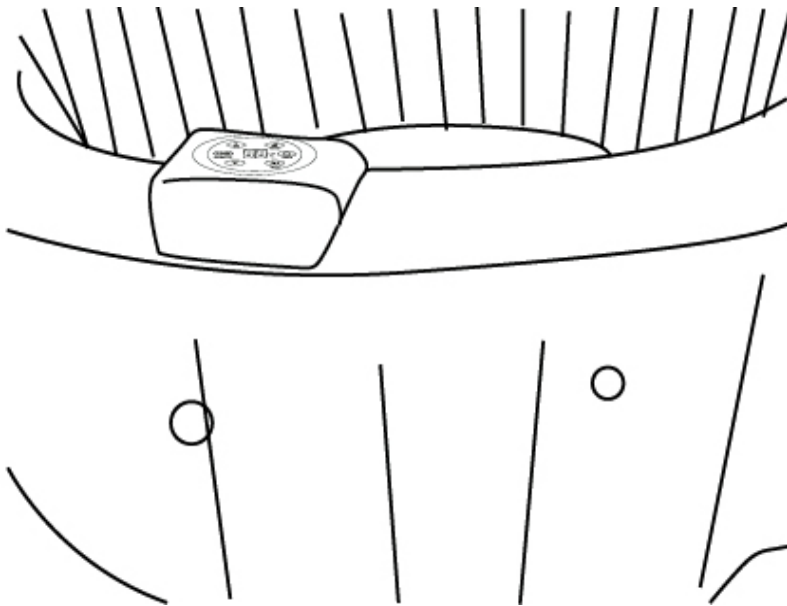

1. Filling the spa with water: water should be filled to a position 1 inch higher than the water line. If lower, the heating system may not turn on. If higher, water may spill over the spa side while in use.

2. Maintenance of spa water.

2.1 Water in the water tank body should be filtered at fixed time regularly. It is not suggested to filter the water at all times.

2.2 The spa water should be treated with chemicals as needed. However, chemicals with calcium ions must not be used. If chemicals containing calcium ions are used for water treatment, there is a good chance of scale to form on the walls of the spa and inner heating pipes. Water scales will directly damage the inner electrical components inside the control equipment and further affect the service life of control equipment.

2.3 If the filtration system has worked for 168 hours, the system will emit a warning tone to remind the user to clean or replace the filter cartridge.

3. Conservation of SPA: Drain the water from inside the spa completely and wipe off droplets of water on the walls. After that, lay aside the SPA for 24 hours, deflate the air and fold. If it is winter, please fold the Spa indoors, because outside temperature in winter is very low and materials may become hard. In that case, folding the materials may result in breakage. Put the Spa inside the packing case after folding it and then put the case in a shaded place to avoid direct sunlight.

MAINTAINING

Maintaining water

1. Clean your filter cartridge at least once every time you have used a your spa approximately for 72- 120 hours. The filter cartridge should be replaced at least once a month depending on use.
2. Change water every few days or use appropriate spa chemicals. All spas require the use of spa chemicals. Please consult your local spa supply retailer for more information about chemical maintenance. Pay close attention to the chemical manufacturer's instructions. Spa damage resulting from misuse of chemicals and mismanagement ofspa water is not covered by the warranty.
 - a. Water balance; we recommend you maintain your water PH between 7.2 and 7.8, total alkalinity between 80and 120ppm and free chlorine between 3 to 5ppm. Purchase a test kit to test your water chemistry before each use of the spa, no less than once per week. Low PH will cause damage to the spa and pump. Damaged resulting from chemical imbalance is not covered by the warranty.
 - b. Water sanitation is the responsibility of the spa owner, achieved through the regular and periodic (daily, if necessary) addition of an approved sanitizer. The sanitizer will chemically control bacteria and viruses present in the water or introduced during use of the spa.

Automatic Filter Replacement Reminder

When the FILTER PUMP has worked for 168 hours, the letters 'FC' will appear on the display screen, accompanied by a warning tone. This is a reminder that it is time to change out your filter cartridge. At this time, the indicator light on the filtration button will be on but the filter pump will actually not work. The heating system will also stop working. Only by pressing the 'FILTER' button again will the indicator light on the filtration button turn off and the letters 'FC' on the display screen will disappear and the warning tone will stop. The water temperature will be displayed again and all buttons return to normal working status.

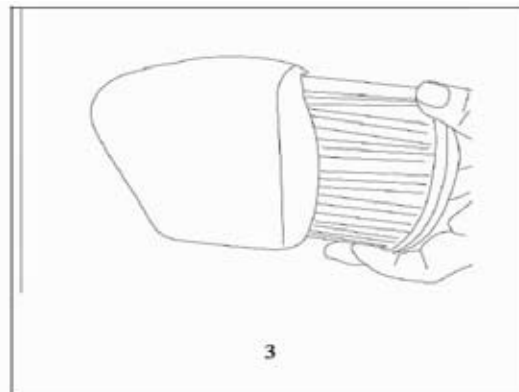
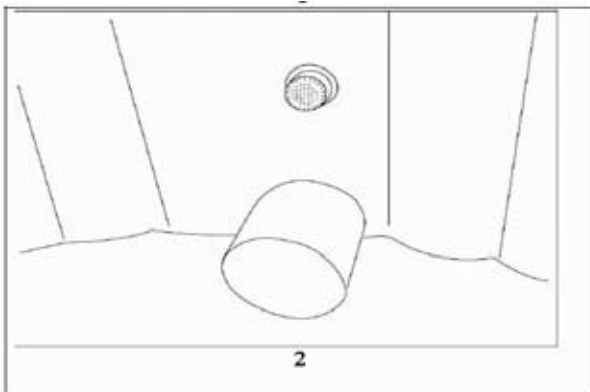

Cleaning the filter cartridge

1. Make sure to unplug the power pack from the electrical receptacle before the following actions.
2. Unscrew the filter cartridge by turning counterclockwise.
3. Remove the filter cartridge cover.

4. The filter cartridge can be rinsed off with a garden hose and reused. However, if the filter cartridge remains soiled and discolored the filter cartridge should be replaced.

5. Put on the filter cartridge cover and place the filter cartridge to water inlet by turning it clockwise.

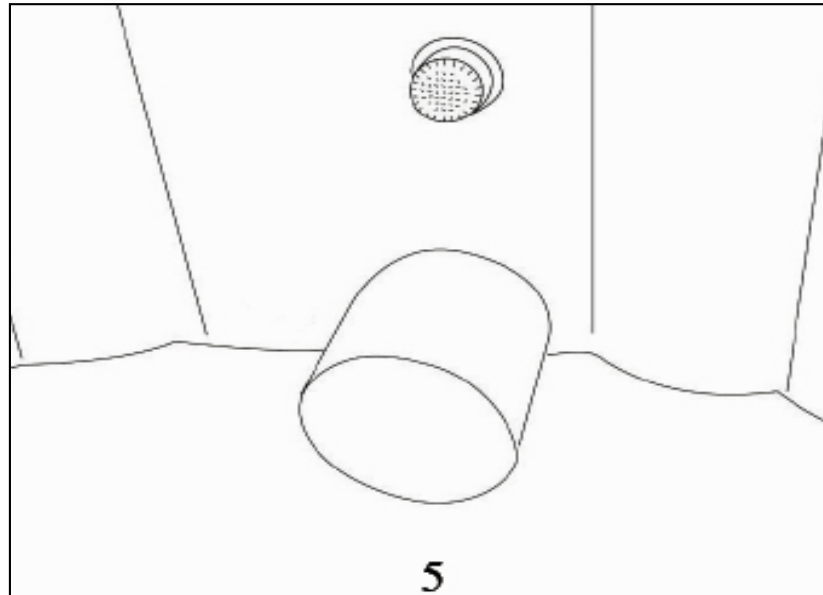
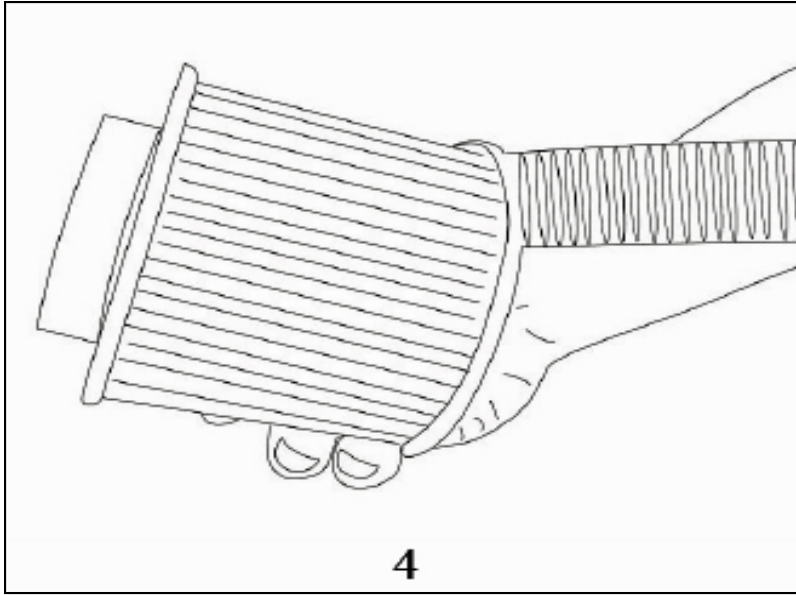

Drainage

1. Make sure to unplug the power pack from the electrical receptacle.
2. Put the plastic plug into the outlet in the inner wall of the spa.
3. Open the outlet in the outer wall of the spa. Screw one end of inflation hose into it.
4. Pull the plastic plug off from the outlet in the inner wall of the spa, then the water will flow out.

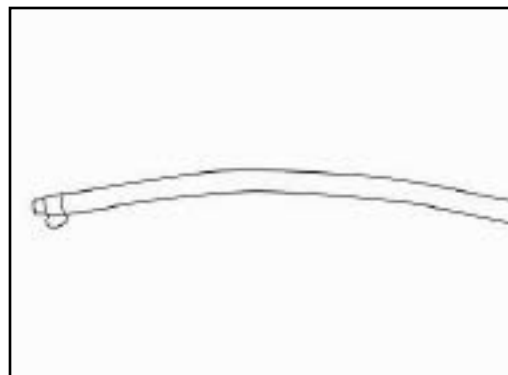
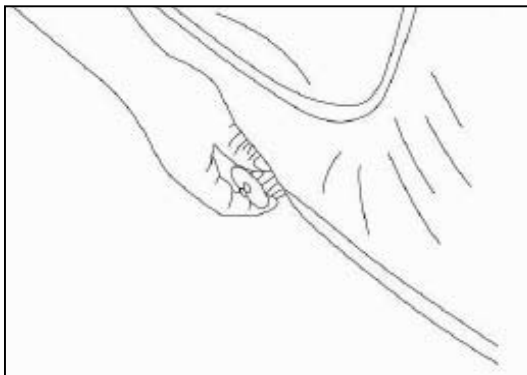

5. When there is no more water in the spa, you must turn on the jet function 2-3 minutes by pressing the “Bubble” button to drain the water in the air pipeline.

WARNING: DO NOT PUSH ANY OTHER BUTTON BUT THE BUBBLE BUTTON, OTHERWISE YOU WILL BURN UP THE PUMP, HEATING, FILTER SYSTEM.

6. When drainage is finished, remove the inflation hose and screw the nut tight.

Cleaning the spa

Detergent residues and dissolved solids from bathing suits and chemicals will gradually accumulate in the spa's water. To clean the spa, use soap and water then rinse.

Note: do not use hard brushes or abrasive cleaners.

REPAIR AND STORAGE

1. **Spa Repair** - If the spa is torn or punctured, use the provided repair patch Dry the area to be repaired. Apply the glue from the accessory bag to the repair patch and then attach it onto the damaged area. Smooth the surface to remove any air bubbles. A secure unnoticeable repair can usually be made.

2. **Spa Storage** - Make sure all water is drained from the spa and control box. This is essential to extend the life of the spa. We recommend the use of a wet/dry vacuum to blow out or suck up water from the spa pipes and pump lines. Remove the filter cartridge. It is recommended you store the spa in its original package in a warm dry place.

Note: Plastic becomes brittle and susceptible to breakage when exposed to subzero temperatures. Freezing can severely damage the spa. Improper winterization of your spa may void your warranty.

TROUBLE SHOOTING

Here are some helpful tips to help you to diagnose and rectify some common sources of trouble.

Problems	Probable causes	Solutions
Jet system does not operate	---Air pump is too hot ---Something is wrong with the power box	---Unplug the air pump. After the air pump has cooled,insert the plug and press the Jet button to activate. --- Call for service if it does not reset.
Heating system does not operate	---Temperature set too low ---Dirty filter cartridge ---Improper water levels ---Heating element failed	---Set to a higher temperature (68 - 104°F). ---Clean/replace the filter cartridge in time. ---Add water to specified levels. --- Call for service.
Filtering system does not operate	---Dirty filter cartridge ---Something is wrong with the power box ---Too low voltage or incorrect frequency	---Clean/replace the filter cartridge in time. ---Call for service if it does not reset. ---Ask professional electrician to check whether the household input voltage or frequency is normal
Spa leakage	---Spa is torn or punctured	---Use provided repair patch
Water not clean	---Insufficient filtering time ---Dirty filter cartridge ---Improper water maintenance	---Increase filtration time. ---Clean/replace the filter cartridge. ---Refer to the chemical manufacturer's instructions

WATER PROTECTION LEVEL

Warning: Water protection levels of the spa at different product zones are different. See the below scheme:

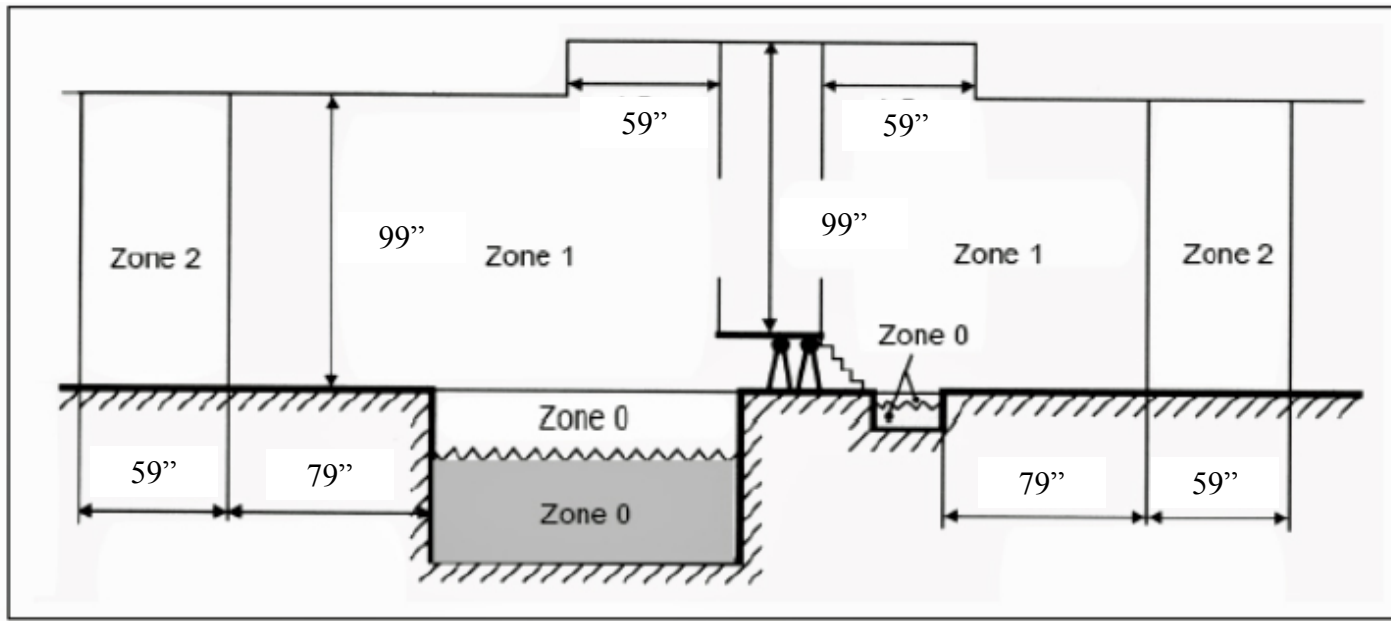

NOTE: The measured zone dimensions are limited by walls and fixed partitions. Above figure--Zone dimensions of swimming pools and paddling pools.

Zone 1

Note: The measured zone dimensions are limited by walls and fixed partitions. Above figure—Zone dimensions of swimming pools and padding pools.

SAFETY & ANNOUNCEMENTS

1. A local supplementary equipotent bonding shall connect all extraneous conductive parts in Zones 0, 1 and 2 with protective conductors of all exposed conductive parts situated in these zones.
2. The measures of protection by non-conducting location and by earth-free equipotent bonding are not permitted.
3. Electrical equipment shall have at least the following degrees of protection:
4. Junction boxes shall not be installed in Zones 0 and 1 except in zone 1, where permitted for SELV circuits.
5. In Zone 0: IPX8
6. In Zone 1: IPX5
7. In Zones 0 and 1, no switchgear and accessories shall be installed.
8. The transformer must be located outside zone 1.

We decline liability for any damage or accident derived from any use of this product which is not in conformity with the instructions contained in this booklet.

LIMITED WARRANTY - TERMS & CONDITIONS

This warranty extends to the original purchaser only. The warranty period commences on the original purchase date through 6-12 months according to the different parts. This warranty is not transferable to subsequent purchasers. This warranty is subject to the obligations, limitations, and exclusions listed below.

- **Extent of warranty:** 6 months warranty on spa body and plumbing, 12 months spa pak and electric parts.

- Obligations of purchaser

The purchaser must establish by dated sales slip, invoice, or installation receipt, the date of original purchase. Transportation costs incurred to and from the manufacturer or authorized service center is the responsibility of the purchaser. This includes freight charges for parts shipped to the dealer or service center. All costs for the removal or reinstallation of parts are the responsibility of the purchaser. You may be subject to dealer service charges. Factory labor is defined as labor required to test and to perform repairs to components returned to factory at customer expense provided defective components are returned within specified warranty period.

- Limitations and exclusions

The warranty is a limited warranty. It covers the spa itself for the period stated. This warranty negates or limits all other warranties implied or expressed, except for those, which can not be negated or limited by law of the state in which the product is used. The manufacturer does not authorize or permit any party, including its agents, distributors or dealers to assume for it any other obligations or liability. In no event will the manufacturer be liable for any claim for damages arising from the use or loss of use, installation, or repair of the spa including, but not limited to freight damage, punctures, cuts in vinyl, water and/or sewage costs, freeze damage, or water damage to surrounding areas, rooms, furnishings or landscaping. The purchaser is responsible for providing adequate access to all areas surrounding the spa so that service may be properly performed. Product specifications are subject to change without notice.

- Acts invalidating warranty

This warranty is void if the spa has been altered, misused, abused or has been repaired by an unauthorized person, or is not installed according to the factory instructions. Other acts that will void the warranty are operating the spa without water or improper water level, use of an extension cord, improper chemical maintenance, burying the spa below ground level, damage from ice or freezing, low voltage or excess voltage. This warranty gives you specific legal rights. Specifications are subject to be changed without notice.

SPA REGISTRATION and CUSTOMER SERVICE

Aqua Spa Customer Service Phone Number and Email: (800) 279-1906 , service@firstspausa.com

Spa Registration - Please go to **www.firstspausa.com** to register your spa. Go to “Spas” tab and from the drop down menu choose “Aqua Spa Registration”. Fill out the form completely and click the send button.

OR fill out the included spa registration form and mail it to; First Spa USA, 171 West 7065 South, Midvale Utah 84047.

AQUA SPA REGISTRATION

Full Name:

Email:

Phone:

Address:

City:

State:

Zip Code:

Spa Model:

PH500013

PH500015

PH500017

PH500018

Spa Serial #:

Can be found on a white sticker on the box plastic.

**Place of Purchase
and City:**

Date of Purchase:

Comments:

Mail to: First Spa USA, 171 West 7065 South, Midvale Utah 84047.