



Manufacturer's Limited Door Warranty

Exclusive Wood Doors warrants its products (factory finished or unfinished) sold under this limited warranty, if not expressly excluded from this guaranteed to be of quality material and workmanship and to be free from defects at the time of shipment for 5-years on Mahogany (Mara Macho) doors, and 1-year on all other wood species, glass inserts and factory finishing from the date of purchase that would render them unserviceable or unfit for the ordinary purposes for which each door is usually recommended.

This warranty takes precedence over all other warranties, expressed or implied.

Exclusive Wood Doors will (1) repair, (2) replace or (3) refund, at our sole discretion, any defective part or product to be defective within the specified warranty period. Exclusive Wood Doors maximum liability is limited to the amount of the original purchase price and will not cover the costs of labor, installation or finishing for any replacement door. The manufacturer shall not be liable for doors repaired or replaced without its prior written consent.

- In the case of damage, misuse or abuse caused by other parties, or beyond the control of Exclusive Wood Doors. All products must be inspected upon receipt of shipment, damage claims are void after product has been received and signed for as "Free of Damages". In the event of damages, contact our customer service team within 24 hours of receipt of shipment and make notations to the freight carrier bill of lading.
- In the case of an obvious defect upon receipt of shipment from the manufacturer, notice must be given within 30 days thereafter and before the door/unit is hung, installed or treated in any manner.
- Written notice of any claim under this guarantee must be reported to the manufacturer or its agent promptly when discovered, and in any event within the 5-year or above stated warranty period pertaining to the product.

ALLOWABLE TOLERANCES

Warp shall not be considered a defect unless it exceeds ¼" inch in the plane of the door itself. Warp is any distortion in the door itself, and does not refer to the relation of the door to the frame or jamb in which it is hung. The term warp shall include bow, cup, and twist.

- In measuring the amount of warp present in a door the following method shall be used: Bow, cup, and twist shall be measured by placing a straightedge, taut wire or string on the suspected concave face of the door at any angle (i.e., horizontally, vertically, and diagonally), with the door in its installed position. The measurement of bow, cup, and twist shall be made at the point of maximum distance between the straightedge, taut wire, or string and the face of the door. Action on any claim for warp or photographing may be deferred at the option of Exclusive Wood Doors for a period not to exceed 12 months from the date of claim. If a door has been installed prior to such claim being made, the door must remain hung in the original installation during the period of deferment, to permit conditioning to humidity and temperature.

MATTERS EXCLUDED FROM THIS WARRANTY

An overhang is required to retain this warranty.

The protective overhang is equal to, or greater than the distance from the bottom of the threshold to the base of the overhang. The following are circumstances that are not considered the responsibility of Exclusive Wood Doors and will void the warranty:

Natural variations in color or texture of the wood are not to be considered defects.

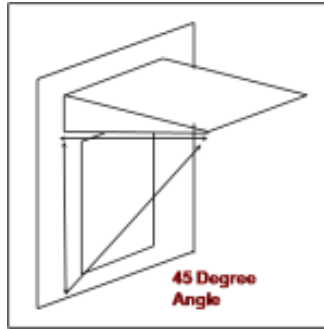

- Doors in excess of 36” in width or 96” in height.
- Failure to properly seal and finish all door/sidelite/transom surfaces, edges and or jambs. This includes bores, mortis pockets, and multipoint prep.
- Unsatisfactory service or appearance caused by failure to follow the “Handling, Care & Maintenance, and Finish Instructions” set forth herein is not covered under and or by this warranty.
- The install of any damaged product, or modification, repair or replacement without written consent from Exclusive Wood Doors.
- Any use of the product other than for which it was intended, doors that are not properly hung and do not swing freely.

Exclusive Wood Doors shall not be liable for consequential, indirect, or incidental damages, or any amount in excess of the manufacturer’s price for the shipment involved, whether the claim is for breach of warranty or negligence.



EXCLUSIVE WOOD DOORS

Solid Integrity in Every Opening

Handling

UPON RECEIVING YOUR DOOR UNIT:

Exclusive Wood Doors recommends that you inspect and clean your doors and wood frames upon receipt and a minimum of once a year.

1. Inspect doors, wood frames and components for any visible damages or defects.
 2. In you receive glass, inspect and check glass for any visible damage.
 3. Replace or repair damages or defects.
> You can contact Exclusive Wood Doors or your local Exclusive Wood Doors dealer for repair or replacement.
 3. Do not install any defective and or damaged door, frames and components as installation will void the warranty.
 4. In case of freight damage, it is your responsibility to refuse shipment and note damage on bill of lading.
 5. Concealed damages will not be covered after 24 hours of receiving door, frames and components.
 6. Labor costs will not be covered by warranty once damaged of defective product has been installed.
-

STORAGE AND HANDLING OF YOUR DOORS

1. Doors should be stored flat on a level surface, never store your doors standing or leaning against a wall.
2. Doors should not be exposed to humidity or direct sunlight. Doors should be stored in a dry and ventilated area.
3. Handle doors with care, avoid dragging across surfaces and keep doors clean.
4. Exposed wood (if doors received unfinished) must be immediately sealed and finish-coated on all surfaced and edges.



Wood Care & Maintenance

WOOD CARE & MAINTENANCE

You may be required to perform periodic inspection and cleaning, maintenance is necessary to achieve the lasting value and impression of our solid wood doors. Such maintenance is not included in our limited warranty, and may vary depending upon exposure to environmental conditions, frequency of use, and other factors. Timeliness in the finishing of wood is essential. Moisture and relative humidity affect wood. In addition to achieving a certain appearance, the primary purpose of finishing is to protect the wood surface, as well as provide a cleanable surface. Well-maintained factory and non-factory finishes are required to remain under warranty.

Finish life and longevity varies, while the finishing on our solid wood doors includes high quality materials and detailed processes, periodic maintenance is necessary to enhance the life span and appeal of your door.

All wood pieces are unique. Natural variations in wood grain exist and may cause tonal and grain depth variations. These natural variations do not represent a defect in the wood.

Visual inspection:

1. Inspect for evidence of dulling, and minor surface variations.
2. Inspect for surface cast cloudiness to the final finish.
3. Inspect for superficial cracks in the final finish coat.

The following conditions serve as indicators for the need to restore your finish. Inspect your door for such conditions periodically.



EXCLUSIVE WOOD DOORS

Solid Integrity in Every Opening

Finishing

All of our solid wood doors are available with a premium stain factory finish that emphasizes wood grain and the natural beauty of our wood doors. This is an optional added benefit, and is not required.

If you are receiving your doors/unit unfinished the following should serve as a guide.

PREPARATION FOR FINISHING:

To achieve the quality desired appearance, preparation for finishing is very important.

1. Remove all handling marks and other undesirable blemishes if any.
 2. Sand to eliminate surface imperfections by softening and smoothing the wood to develop a quality surface ready to finish.
 3. Sand with the natural wood grain to avoid cross-grain scratches.
-

EXTERIOR FINISHING:

Once you have completed the preparation for finishing, you may begin the finishing process.

1. Apply stain hand-wiped, using a wipe rag ensures that stain is applied evenly throughout. Keep in mind each piece of wood is unique, natural variations of grain exist.
2. Apply sealer coat, once the sealer has cured, the surface is fine-sanded between the application of coats to develop a smooth surface for varnish application. Exclusive Wood Doors recommends the application of two coats.
3. You are now ready to apply a UV protected satin varnish. Once the UV protected stain varnish has cured, the surface is fine-sanded for the application of another coat if desired. Exclusive Wood Doors recommends the application of two coats.