







Thomasville®

Assembly Instructions
Messina™ Dining Table
Model #: I2255-002 / 012
Model #: I2255-003 / 013
Model #: I2255-004 / 014

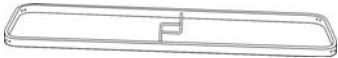
Thank you for purchasing this quality product. Be sure to check all packing materials carefully for small parts that may have come loose inside the carton during shipment. Please read all instructions carefully before starting the assembly process.

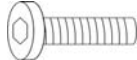
CAUTION: Some items and/or the components are cumbersome and heavy. Therefore, the assistance of one or more people is recommended in order to prevent personal injury and insure that the item and/or its components are not damaged during the assembly process. Perform all assembly steps on a flat, soft, non-abrasive surface to avoid scratching the finish. Do not over tighten the screws or bolts.

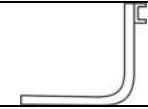
Hardware & Parts List

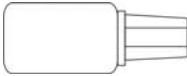
No.	Description	Picture	Qty
A	Table Top		1
B	Leg Connector Bracket		1
C	Table Legs		4
D	Screws (1/4" x 1 3/16")		26
E	Washers (Ø1/4")		26
F	PVC Screw Covers		26
G	Support Braces		2
H	Hex Key		1
I	Touch-up Paint		1

Note: The touch-up paint (I) was provided for touching up minor nicks or scratches to your metal dining table parts as needed.

! KEEP THESE INSTRUCTIONS FOR FUTURE REFERENCE !

Assembly Instructions
Messina™ Dining Table
Model #: I2255-002 / 012
Model #: I2255-003 / 013
Model #: I2255-004 / 014

1. Align the holes in the table legs (C) and support braces (G) with the holes in the bottom of the table top. Loosely attach the four table legs and two support braces using the screws (D), washers (E), and hex key (H). Do **NOT** completely tighten the screws at this time. See **Figure 1**.

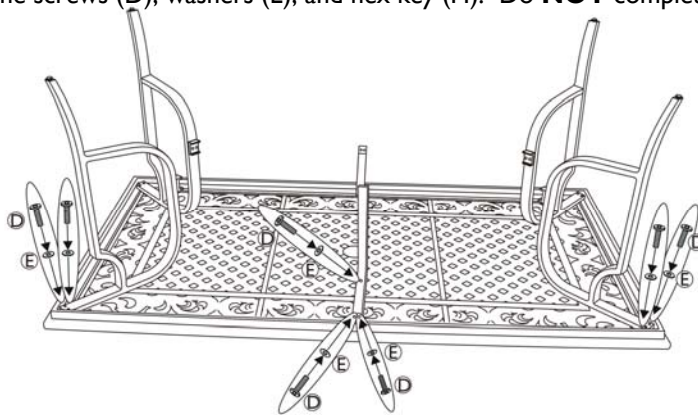
Figure 1

2. Attach the leg connector bracket (B) to the table legs (C) and support braces (G) using the screws (D), washers (E), and hex key (H) as indicated. See **Figure 2**. When attaching the leg connector bracket (B), insert and start all twelve screws before completely tightening any of the screws. Once all twelve screws have been inserted, securely tighten all of the screws (including the 14 screws left loose in **Step 1**). After all 26 screws (D) have been securely tightened using the hex key (H), install the PVC screw covers (F). See **Figure 3**.

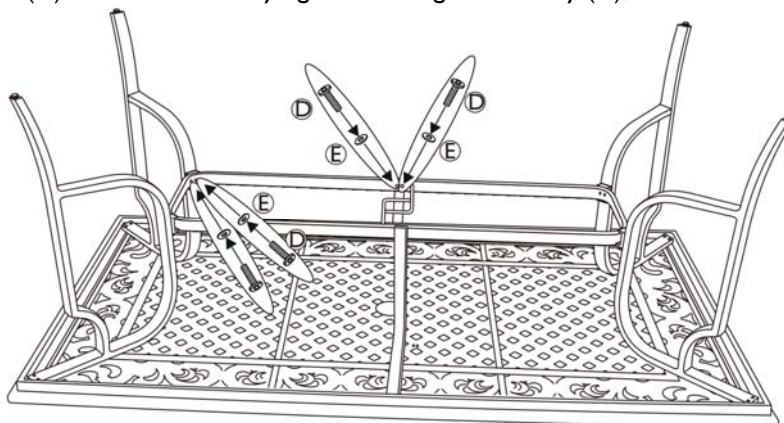
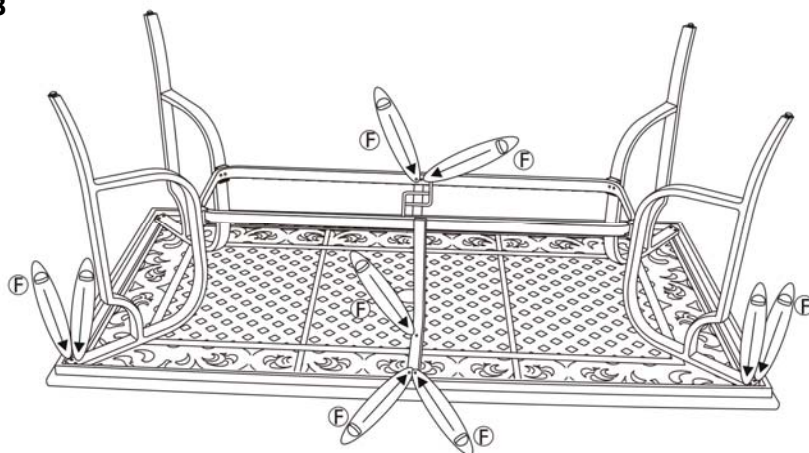
Figure 2

Figure 3

3. Carefully turn the table over into the upright position.

! KEEP THESE INSTRUCTIONS FOR FUTURE REFERENCE !

Instrucciones de Armado

Mesa de Comedor Messina^{MR}

Modelo No.: 12255-002 / 012

Modelo No.: 12255-003 / 013







Modelo No.: 12255-004 / 014

Gracias por comprar este producto de calidad. Revise bien todo el material de empaque para recuperar las piezas pequeñas que puedan haberse desprendido y caído dentro de la caja de cartón durante el transporte. Lea todas las instrucciones detenidamente antes de empezar el armado

ADVERTENCIA: Algunas piezas y/o sus componentes son pesados y difíciles de manejar, por lo que se recomienda que le ayuden en el armado una o más personas para evitarse lesiones y daños a las piezas o sus componentes. Realice todos los pasos de armado sobre una superficie plana, blanda, no abrasiva, para evitar rayones al acabado. No apriete demasiado los tornillos ni los pernos.

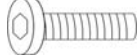

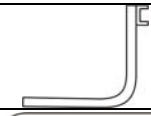
Lista de Herrajes y Piezas

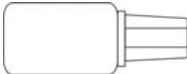
No.	Descripción	Dibujo	Ctd.
A	Encimera		1
B	Soporte para conectar las patas		1
C	Patatas de la mesa		4
D	Tornillos (1/4" x 1 3/16")		26
E	Arandelas (DE 1/4" DE Ø)		26
F	Tapas de PVC para tornillos		26
G	Soportes		2
H	Llave hexagonal		1
I	Pintura para retoques		1

Nota: La pintura para retoques (I) se suministra para retocar los rayones o golpes menores que sufran las piezas de su mesita de centro, según lo requiera.

¡CONSERVE ESTAS INSTRUCCIONES PARA CONSULTARLAS EN EL FUTURO!

1. Alinee los orificios de las patas de la mesa (C) y de los soportes (G) con los de la parte inferior de la encimera de la mesa. Instale las cuatro patas de la mesa y los dos soportes con los tornillos (D) y las arandelas (E), y use la llave hexagonal (H) para atornillarlos sin apretarlos completamente. **NO** apriete los tornillos por completo en este momento. Vea la **Figura 1**.

Figura 1

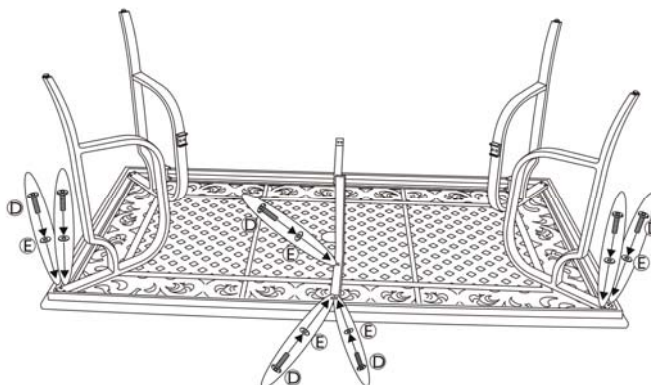

2. Fije el soporte que une las patas (B) a las patas de la mesa (C) y a los soportes (G), con los tornillos (D), las arandelas (E) y la llave hexagonal (H), como se indica. Vea la **Figura 2**. Para esto, introduzca y enrosque los doce tornillos en los orificios, antes de apretarlos por completo. Una vez introducidos los doce tornillos, apriete bien cada uno de ellos (incluyendo los 14 tornillos que quedaron sin apretar en el **Paso 1**). Una vez que apriete bien los 26 tornillos (D) con la llave hexagonal (H), coloque las tapas de PVC para tornillos (F). Vea la **Figura 3**.

Figura 2

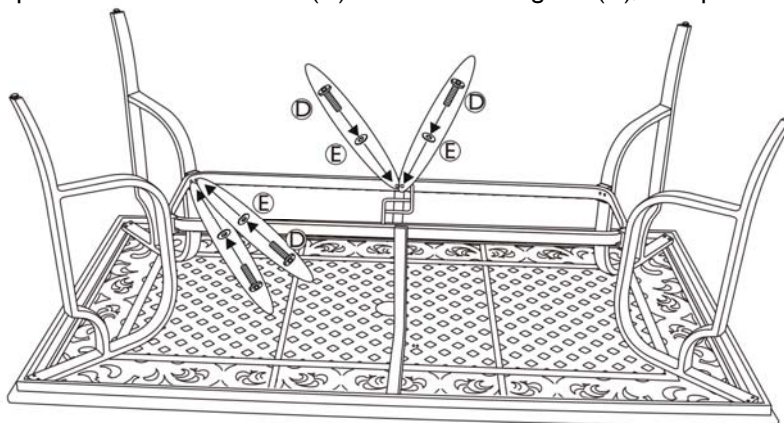

Figura 3

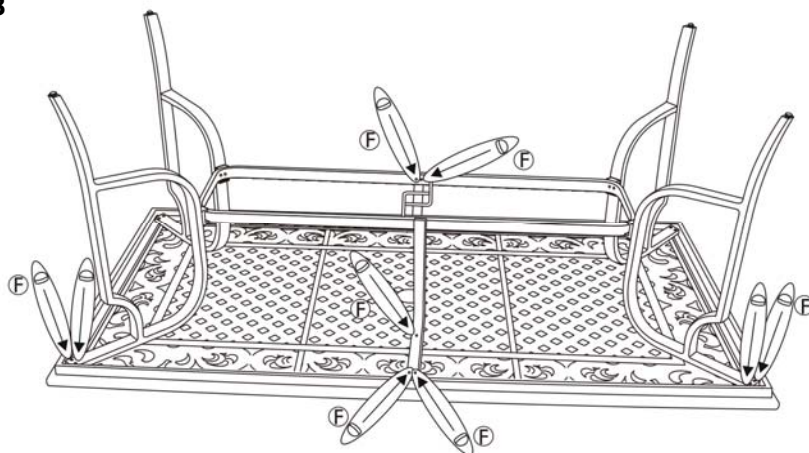

3. Ponga la mesa patas arriba con cuidado.

¡CONSERVE ESTAS INSTRUCCIONES PARA CONSULTARLAS EN EL FUTURO!