

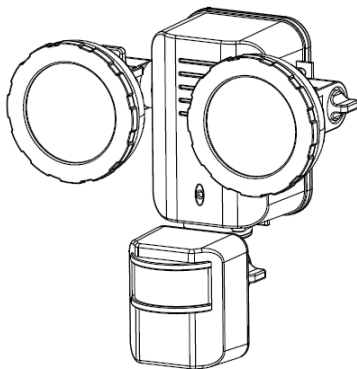

**Motion Activated
Solar Powered LED
Security Light
MODEL: PSO1**



Please do not return this item to the store.

For service or questions about your solar light, call our customer service at 800.284.8828 (8:30am - 5:30pm, Monday to Friday, Pacific Time) or visit

www.xepatech.com.

Introduction

Thank you for purchasing the PSO1 Solar Powered Security Light—the most cost-effective way to illuminate and protect your home, business, and recreational areas. With its easy setup and lightweight design, this light conforms to most of your lighting needs and is especially useful wherever an electrical outlet is not accessible.

The PSO1 Solar-Powered Security Light converts solar energy to electricity so that lighting is available wherever and whenever you desire. Simply install or set the solar charging panel where sun exposure is prevalent. The attached 15' cable provides sufficient length for easy placement. In AUTO mode, (normal operation setting) the light illuminates at night only when motion is detected, then automatically resets.

Important Safety Information

- **Do not expose the light to fire or intense heat.**
- **Do not immerse in water.**
- **Never look directly into the light or shine it in another person's eyes.**
- **Dispose of the battery in accordance with local, state and federal regulations. (Do not burn or discard the battery in a municipal water system or other body of water.)**
- **Consult your local safety guidelines for installing the light fixture on a building.**
- **Only use batteries from XEPA TECHNOLOGIES to ensure compatibility. (Refer to the product's original battery for correct size.)**
- **Always position the battery so it has the correct polarity: (+) and (-).**
- **Light will not work once battery is removed from the jacket. Please plug in the solar panel charger or any other approved power adaptor after put battery back to the jacket to reactivate the light.**

What's Inside the Package:

- PSO1 solar light with battery
- Solar charging panel with 15' cable
- User manual including installation template for the light and solar panel
- Screws & anchors

Features:

- Solar powered lighting, no electricity bill
- 2 x 5W super bright LEDs (equivalent to 60W incandescent)
- Motion detection at a distance of up to 50 ft.
- Two lamp heads for dual direction illumination
- Auto illumination from dusk to dawn High-efficiency, rechargeable lithium battery produces zero emissions

Product Profile:

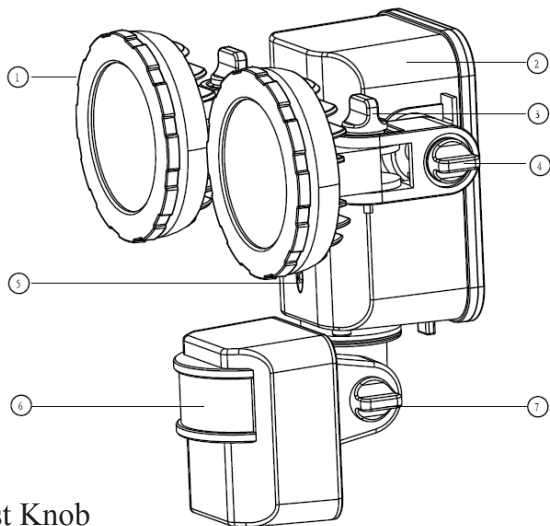

1. Lamp Head
2. Battery Housing
3. Horizontal Adjust Knob
4. Vertical Adjust Knob
5. Motion Activated Indicator
6. Motion Sensor Lens
7. Adjust Knob

Installation Recommendations:

- The PSO1 light fixture should be installed on a flat and stable surface— the higher the light is placed, the larger the area of illumination.
- Avoid installing the light near an air conditioner, heater or high-voltage system, since quick changes in temperature may activate the motion- detection system and run down the light's power.
- Avoid positioning the motion sensor head towards street traffic, or where other movements may trigger the light needlessly and drain the battery.
- The solar panel should be installed facing the sky where direct sunlight can shine on the panel at least 6-8 hours per day. (Before initial use, the panel will need 2-3 days of sunlight exposure to fully charge the battery.)
- The motion sensor is most sensitive to movement across the device and less sensitive to motion directly towards or away from it.
- Periodically use a soft damp cloth to clean accumulated dust or snow off of the solar panel. This will preserve the panel's efficiency when charging the battery.

Installing the LED Security Light:

1. Mark holes on the wall through the Installation template.
2. Drill holes with a 3/16” drill bit.
3. Gently tap the plastic anchors into the holes until they are flush with the mounting surface.
4. Secure the screws into the plastic anchors—leave approximately 3/16” of each screw exposed for mounting the unit.
5. Place the light unit over the screws—gently push down on the unit to slide the screws into locking position.

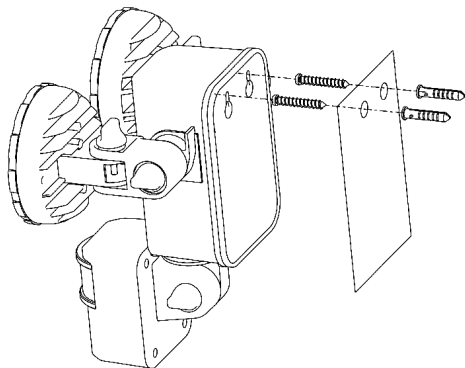

6. Rotate/tilt the motion-detection sensor towards the desired coverage area.

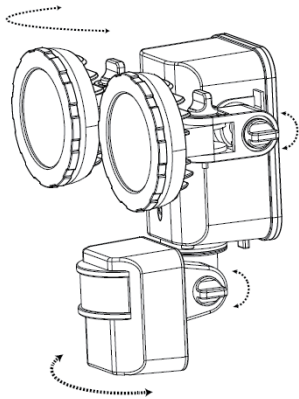

Installing the Solar Panel:

1. Find a location for the solar panel that receives direct sunlight for a minimum of 6-8 hours a day and is within 15' of where the Security Light will be installed.
2. Mark the holes through the installation template.
3. Using a 3/16" drill bit, drill holes in the spots you marked.

4. Gently tap the mounting anchors into the holes until they are flush with the mounting surface.
5. Place the base of the solar panel over the drilled holes—secure the screws through the base into the plastic mounting anchors.
6. Extend the cord from the solar panel to the light box—completely insert the cable plug into the INPUT hole located on the bottom of the light unit.
7. Adjust the motion-detection sensor towards the desired coverage area.

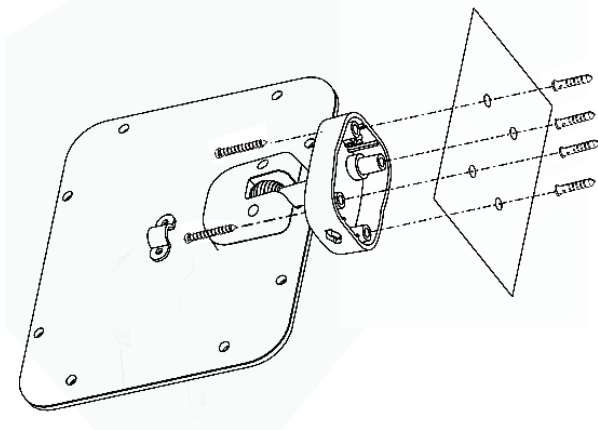

Light Functions:

- OFF: The light will not function; product will be completely off.
- AUTO: The light will remain dormant during daylight hours. At night, the light will activate only when the motion sensor detects an infrared signal, turning off after 60 seconds.
- TEST: LED light will illuminate continuously for 5 minutes and flicker for 1 minute to ensure the appropriate settings are in place. (Be sure to switch the light to AUTO when testing is complete.)

Recharging the Battery:

- Plug in the solar panel charger; the battery will charge whether the switch is set to OFF, AUTO, or TEST positions.
- You can also charge the light with an approved power adapter (9V/2000mA adapter not included in packaging, but available on www.xepatech.com).
- Light will not work once battery is removed from the jacket. Please plug in the solar panel charger or any other approved power adaptor after put battery back to the jacket to reactivate the light.

Warning: Do not mix old and new batteries and Do not mix alkaline, standard (carbonzinc) or rechargeable (ni-cad, ni-mh, etc) batteries. Only Xepa Technology rechargeable batteries should be used! It is available on www.xepatech.com or contact 800-284-8828.

FCC Part 15 Class B

CAUTION: Modifications not approved by the party responsible for compliance could void user's authority to operate the equipment.

NOTE: This equipment has been tested and found to comply with the limits for a Class B digital device, pursuant to part 15 of the FCC Rules. These limits are designed to provide reasonable protection against harmful interference in a residential installation. This equipment generates and can radiate radio frequency energy and, if not installed and used in accordance with the instructions, may cause harmful interference to radio or television reception. The source of the interference can be tested by turning the equipment off and on. The user is encouraged...

- Reorient or relocate the receiving antenna.
- Increase the separation between the equipment and the receiver.
- Connect the equipment into an outlet/circuit different from where the receiver is connected.
- Consult the dealer or an experienced radio/TV technician for help.

Troubleshooting Tips

Symptom	Possible Solution
The light will not illuminate.	<ul style="list-style-type: none">• Make sure the light unit is not set to TEST mode; this will allow the light to illuminate ten minutes.• Make sure the solar-panel plug is fully inserted.• Make sure the battery plug is connected inside the battery compartment.• Before turning the light on for the first time, set switch to OFF or AUTO mode and allow the solar panel to absorb direct sunlight for two or more days to recharge the battery.• Make sure there is no other brighter light source near the unit.• Once battery is removed from the jacket. Make sure plug in the solar panel charger or any other approved power adaptor after put battery back to the jacket to reactivate.

Symptom	Possible Solution
The battery does not fully charge.	<ul style="list-style-type: none"> • While in AUTO mode, if there is frequent activity from dusk to dawn or consecutive overcast days, the solar panel may not convert sufficient ambient daylight to recharge the battery sufficiently. • Reposition solar panel to receive more sunlight. • Clean dust and debris from solar panel. • Make sure the solar panel cable is not damaged.
The light stays on continuously while in AUTO mode.	<ul style="list-style-type: none"> • Check the motion detector to ensure that it is not directed towards street traffic or where other movements may trigger the light needlessly.
Motion has not been detected within the coverage area.	<ul style="list-style-type: none"> • Check the motion sensor lens for dust or damage. • Avoid installing the light near an air conditioner, central heater, or hot air flow.

Specifications

Rechargeable Battery: 7.4V/2200mah Lithium-Ion battery

Solar Charging Panel: 12V/3W Mono crystalline

Complies with FCC Part 15 Class B

Luminous Flux: 600lumen

Color Temperature: 6500K

Motion Distance: Up to 50ft

Motion Range: 160°

Switch Model: OFF-AUTO-TEST

Product Size: 8.3"x 4.5"x 7.5"

Solar Panel w/o Stand: 7.0"x 0.6"x 6.0"

Product Warranty & Support Information

For customer support call (800) 284-8828 between 8:30am and 5:30pm, Monday to Friday, Pacific Time or visit www.xepatech.com. This product comes with a limited warranty of 1 year from the day of purchase. (Proof of the date of purchase must be provided if the product is returned.) If the product is found to be defective in material or workmanship, APEX will replace the defective part(s). If any of the product parts are found to be missing, please contact APEX within ten (10) days of purchase.

XEPA TECHNOLOGIES by
APEX DIGITAL INC.
4401 Eucalyptus Avenue, Suite 100
Chino, California 91710



is a registered trademark of The Coleman Company, Inc., used under license. ©2011 The Coleman Company, Inc.

Made in China
2011-12-23

