

# PROMPT SET™ Spa

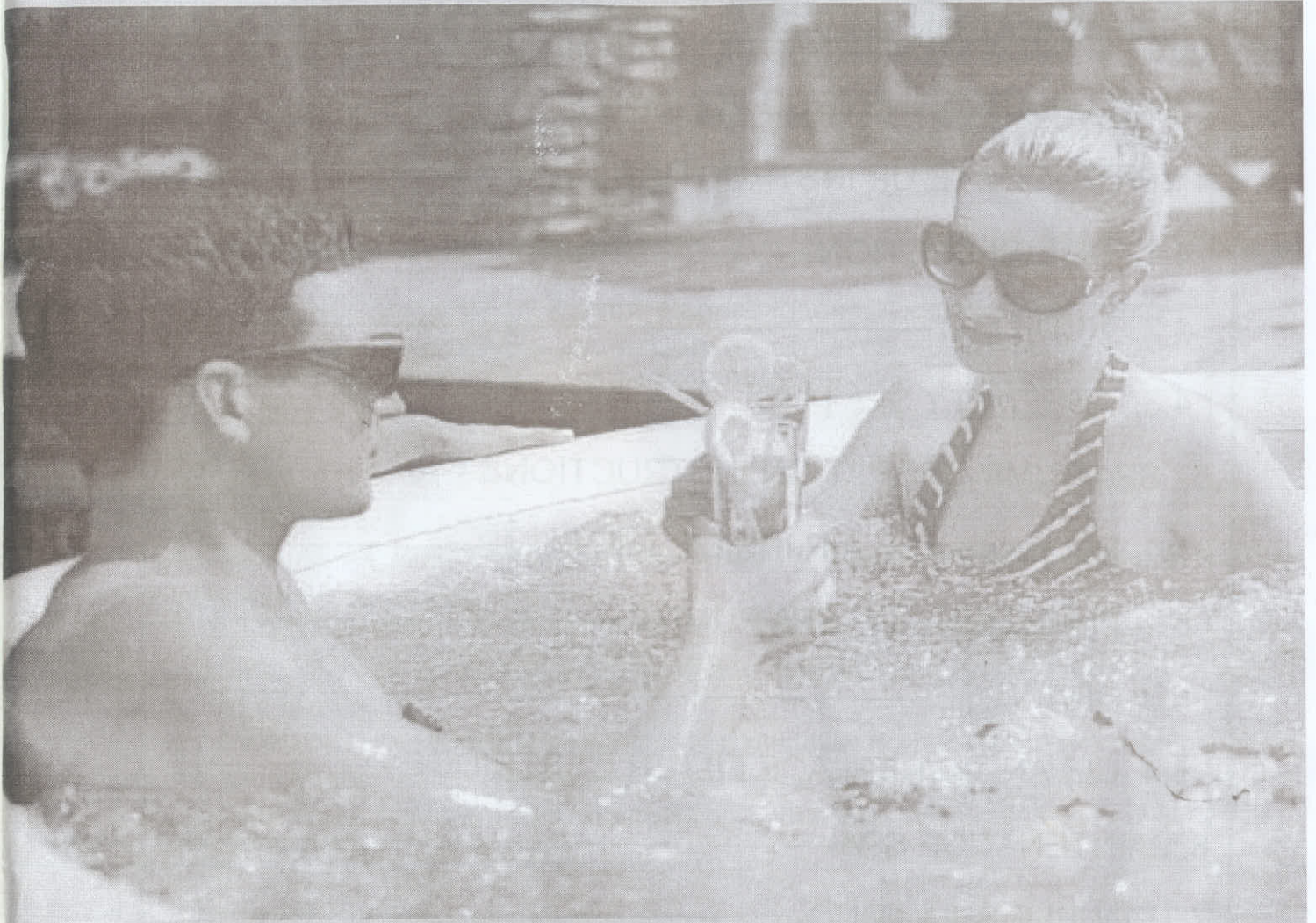

JL017146NG/NE/NAU  
JL017145NG/NE/NAU  
JL017144NG/NE/NAU  
(220-240V 50Hz 2000W)

JL017146NN  
JL017145NN  
JL017144NN  
(110-120V 60Hz 1320W)

## ATTENTION:

- PLEASE READ CAREFULLY AND SAVE FOR FUTURE REFERENCE!
- DO NOT RETURN THIS PRODUCT TO THE STORE. PLEASE CALL OUR LOCAL AFTER SALES SERVICE CENTER FOR HELP OR EMAIL US.

PROMPT SET SPA



PSSP2-13-2L

## TABLE OF CONTENTS

1.IMPORTANT SAFETY INSTRUCTIONS	3
2.SPECIFICATIONS	6
3.INSTALLATION INSTRUCTIONS	7
4.SPA POOL STE UP INSTRUCTIONS	8
4.1. SITE SELECTION	8
4.2. RCD TEST	9
4.3. ASSEMBLY SPA POOL	10
5. SPA PUMP OPERATION INSTRUCTIONS	14
5.1 RELEASE THE AIR INSIDE THE PUMP	14
5.2 FUNCTIONS OF SPA PUMP	14
5.3 DRAINAGE	16
5.4 CLEANING/REPLACE FILTER CARTRIDGE	18
6.MAINTENANCE SPA	20
7.TROUBLE SHOOTING	23
8.FREQUENT PROBLEMS SOLUTION	25
9.LIMITED WARRANTY	27

## WARNING

When installing and using this electrical equipment, basic safety precautions should always be followed; including the following:

### IMPORTANT SAFETY INSTRUCTIONS

READ AND FOLLOW ALL SAFETY INSTRUCTIONS

1. **WARNING:** The SPA has been supplied through a residual current device (RCD) having a rated residual operating current not exceeding 30mA. The RCD must be tested before each use.
2. **WARNING:** No part of the appliance is to be located above the bath during use.
3. **WARNING:** This appliance is not intended for use by persons (including children) with reduced physical, sensory or mental capabilities, or lack of experience and knowledge, unless they have been given supervision or instruction concerning use of the appliance by a person responsible for their safety.
4. **WARNING: TO AVOID THE ELECTRIC SHOCK, DO NOT USE THE SPA WHEN IT IS RAINING.**
5. **WARNING:** Children should be supervised to ensure that they do not play with the appliance.
6. **WARNING:** If the supply cord is damaged, it must be replaced by the manufacturer, its service agent or similarly qualified persons in order to avoid a hazard.
7. **WARNING:** To reduce the risk of electric shock, do not use extension cord to connect unit to electric supply; provide a properly located outlet.
8. **WARNING:** Make sure the home fixed connection box shall be more than 3.5m away from the pool.
9. **WARNING: RISK OF ELECTRIC SHOCK. DO NOT BURY CORD.** Locate cord to minimize abuse from lawn mowers, hedge trimmers, and other equipment. To reduce the risk of electric shock, replace damaged cord immediately.
10. **WARNING:** Electric installations should fulfill the requirements of local standards.
11. **WARNING:** Parts containing live parts, except parts supplied with safety extra-low voltage not exceeding 12 V, must be inaccessible to a person in the SPA pool..

**WARNING**

12. **WARNING:** parts incorporating electrical components, except remote control devices, must be located or fixed so that they cannot fall into the SPA pool.
13. **WARNING:** Do not switch on if there is any possibility that the water in the SPA is frozen.
14. **DANGER:** Risk of Electric Shock. Install at least 5 feet (1.5 m) from all metal surfaces.
15. **DANGER:** Risk of Electric Shock. Do not permit any electric appliance, such as a light, telephone, radio, or television, within 5 feet (1.5 m) of a SPA.
16. **DANGER:** Risk of Accidental Drowning. Extreme caution must be exercised to prevent unauthorized access by children. To avoid accidents, ensure that children cannot use this SPA unless they are supervised at all times.
17. **DANGER:** Never operate SPA if the suction fittings are broken or missing. Never replace a suction fitting.
18. **CAUTION:** For below mentioned situation, please always consult your doctor before
  - a) The use of alcohol, drugs, or medication before or during SPA use may lead to unconsciousness with the possibility of drowning.
  - b) Obese persons and persons with a history of heart disease, low or high blood pressure, circulatory system problems, or diabetes should consult a physician before using a SPA.
  - c) Persons using medication should consult a physician before using a SPA since some medication may induce drowsiness while other medication may affect heart rate, blood pressure, and circulation.
  - d) Pregnant or possibly pregnant women should consult doctor before using SPA.
19. **CAUTION:** Always enter and exit the SPA slowly and cautiously. Wet floor are slippery.
20. **CAUTION:** The SPA should not be setup or left out in temperature lower than 10 °C (50 °F).
21. **CAUTION:** In order to avoid a hazard due to inadvertent resetting of the thermal cutout, this appliance must not be supplied through an external switching device, such as a timer, or connected to a circuit that is regularly switched on and off by the utility.

## WARNING

22. CAUTION: Check with a doctor before use if pregnant, diabetic in poor health, or under medical care. Exit immediately if uncomfortable dizzy, or sleepy. SPA heat can cause hyperthermia and unconsciousness. SPA heat in conjunction with alcohol, drugs, or medication can cause unconsciousness.

23. CAUTION: Do not use the SPA immediately following strenuous exercise.

24. CAUTION: Do not add chemical in the water freely, because chemical reaction may impact safety of user or damage the SPA;

25. NOTE: do not run the pump more than 8 hours per day after the temperature reaches to your set point.

SAVE THIS INSTRUCTION FOR FUTURE REFERENCE!

SPECIFICATIONS

Model	Supra		Classic		Deluxe		
Item#	JL017145NG JL017145NE	JL017145NAU	JL017145NN	JL017144NG JL017144NE	JL017144NAU	JL017144NN JL017146NN JL017146NE JL017146NAU	JL017146NN
Protection against electric shock	Class II		Class I	Class II		Class I	
User Capacity	1 Adult		2 Adult + 2 Kids				
Pool Dimension(outer)	67"x46.5"x23.5" (170cmx118cmx60cm)		Ø69"x25" (Ø175cm x 62cm)		Ø70"x25" (Ø178cm x 62cm)		
Pool Dimension(inner)	49"x27.5"x21.5" (125cmx70cmx55cm)		Ø55"x20" (Ø140cm x 50cm)		Ø55"x20" (Ø140cm x 50cm)		
Water Capacity	79 GAL(300L)		185 GAL(700L)		185 GAL(700L)		
Number of Air Jet	88						
Voltage	220-240V 50Hz	110-120V 60Hz	220-240V 50Hz	110-120V 60Hz	220-240V 50Hz	110-120V 60Hz	
Heater	1940W	1320W	1940W	1320W	1940W	1320W	
Air blower	500W						
Filter	60W						
Cord Mounted	RCD(OPTIONAL)	GFCI	RCD(OPTIONAL)	GFCI	RCD(OPTIONAL)	GFCI	
Max. Heat Temperature	40°C(104°F)						

# INSTALLATION INSTRUCTIONS

Note: Ensure to check all parts are present.

Model	Supra	Classic	Deluxe
A-1	Fabric Cover	Fabric Cover	Fabric Cover
A-2	/	/	Inflatable Lid
B	Pump	Pump	Pump
C-1	Inflatable Pool	Inflatable Pool	Inflatable Pool
C-2	/	/	Fabric Pool cover
D	Plastic Buckle	Plastic Buckle	Plastic Buckle
E	Inflation hose	Inflation hose	Inflation hose
F	Connection hose	Connection hose	Connection hose
G	Filter Cartridge	Filter Cartridge	Filter Cartridge
H-1	Stopper Cap	Stopper Cap	Stopper Cap
H-2	PVC film	PVC film	PVC film
H-3	Glue (not included)	Glue (not included)	Glue (not included)
H-4	Drain-pipe stopper	Drain-pipe stopper	Drain-pipe stopper
H-5	Manual	Manual	Manual
H-6	Drain-pipe adapter	Drain-pipe adapter	Drain-pipe adapter

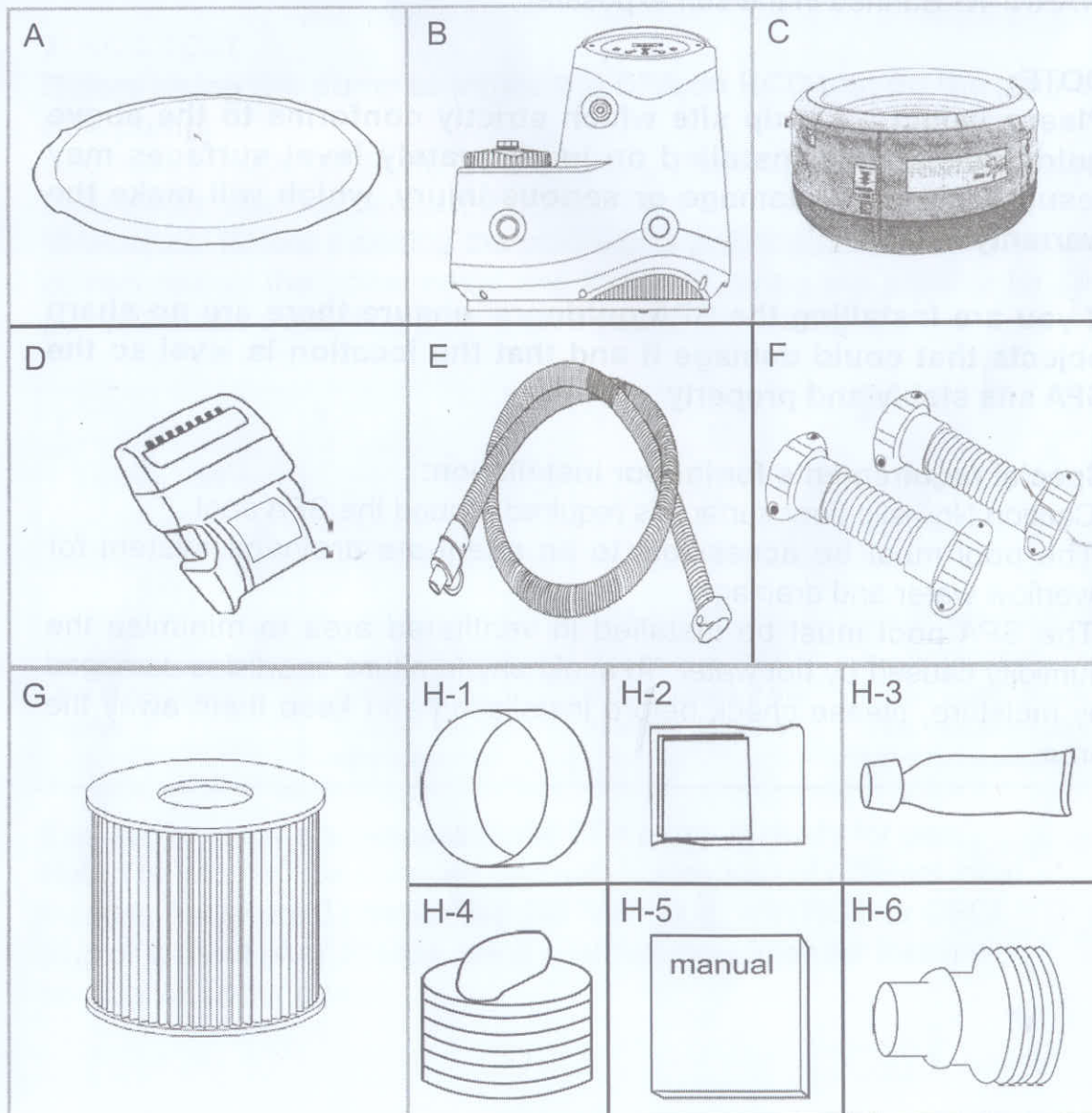

## SPA POOL SET UP INSTRUCTIONS

### 1. SITE SELECTION

#### IMPORTANT GUIDELINE:

- 1.1 Looking for a smooth, flat, level solid foundation to support the weight of SPA and water, plus user.
- 1.2 The pool must be accessible to an adequate drainage system for overflow water.

**WARNING:** To reduce the risk of electric shock, do not use extension cord to connect unit to electric supply; provide a properly located outlet.

**WARNING:** Do not plug up the air drainage hole on inflation hose when blowing up the pool!

**WARNING:** Banned in the sun exposure!

#### NOTE:

**Please select a set-up site which strictly conforms to the above guidelines. Pools installed on inadequately level surfaces may result in property damage or serious injury, which will make the warranty invalid.**

**If you are installing the SPA outdoors, ensure there are no sharp objects that could damage it and that the location is level so the SPA sits stably and properly.**

#### Special requirements for indoor installation:

- Caution: Non-slip floor surface is required around the SPA pool.
- The pool must be accessible to an adequate drainage system for overflow water and drainage.
- The SPA pool must be installed in ventilated area to minimize the humidity caused by hot water. To avoid any furniture or articles damaged by moisture, please check before installation and keep them away the area.



## SPA POOL SET UP INSTRUCTIONS

### Special requirements for outdoor installation:

- Ensure that the area is firm,flat and extremely level,with a grade not exceeding 3° of slope at any point in the set-up area.
- Make sure that the area is completely free of sticks, stones, sharp objects or other foreign debris to damage the pool.
- To prolong the product life of pool, do not expose the SPA pool to direct sunlight for long period.
- We don't recommend to use the SPA pool under 10°C (50 °F ). Heating rate may not satisfy you under too low temperature.
- During filling,emptying or when in use,water may spill out of the SPA,Therefore the SPA should be installed near a ground drain.

### 2. RCD TEST

**Before using the pump to inflate the SPA,do RCD test on the plug of SPA pump:**

**WARNING: RISK OF ELECTRIC SHOCK.** The RCD plug must be tested before each use.Do not use if RCD test fails.

**WARNING:** Before inserting the plug into a power outlet, make sure the current rate of the power outlet and the fixed wiring are suitable for the pump,Contact a qualified electrician if you cannot verify

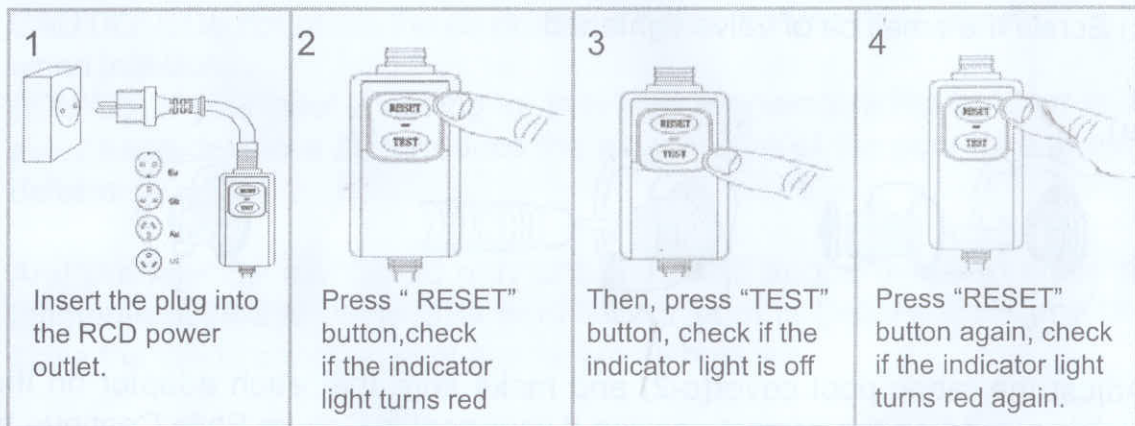

If all above steps are successful,the SPA pump is ready for use.

Note:The plug will be changed with safety standard of different local markets.There are 3 possibilities like "with plug, with RCD or GFCI plug or without plug".Please ask a qualified electrician for installation if no plug with your pump!

## SPA POOL SET UP INSTRUCTIONS

### 3. ASSEMBLY SPA POOL

**WARNING:** Use our SPA pump to inflate the SPA pool. Don't use high-pressure pumps, Over inflation may cause the pool to burst or cause damage, The maximum pressure for all air chambers should be 5.0kpa.

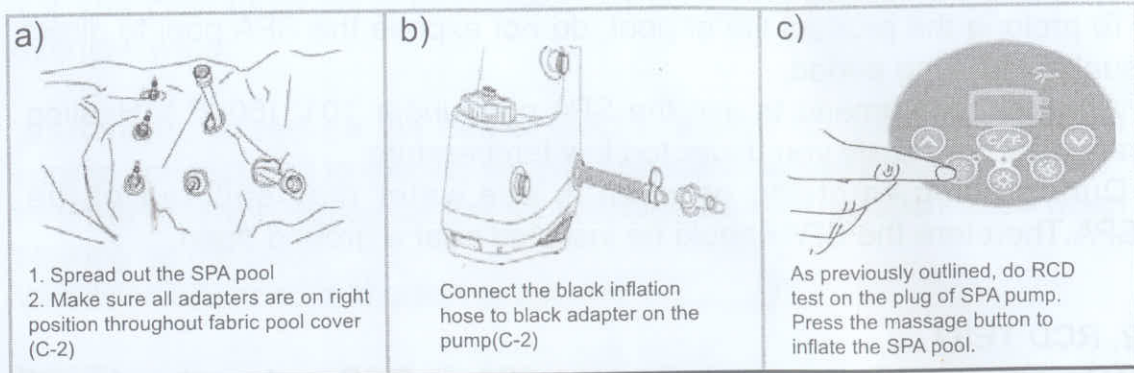

### INFLATION

First, inflate pool bottom. Please close the valve cap and insert the valve body into the vinyl after inflating the bottom. Then inflate pool wall in sequence as per the printed numbers to 80% capacity.

Second, Inflate the pool tube:

- Fix the big ring of valve cap on the base
- Screw the middle part of valve cap on the base and then inflating
- Screw the small ca of valve tightened

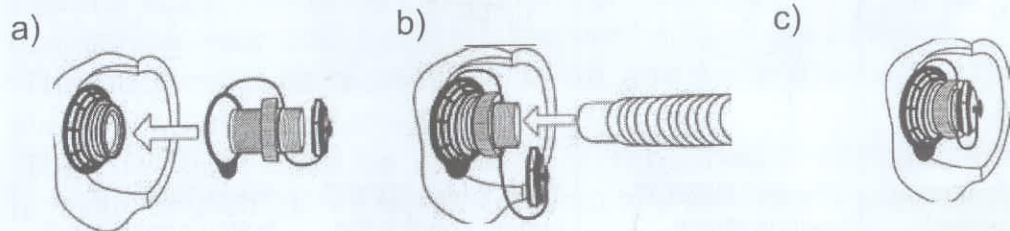

Adjust the fabric pool cover(c-2) and make sure that each adaptor on the wall is placed on the correct position if your pool is Deluxe Style Continue to inflate each chamber until firm and supportive.

## SPA POOL SET UP INSTRUCTIONS

**CAUTION:** Do not over-inflate. Do not try to remove all wrinkles.

**CAUTION:** Inflatable Pool tube will be deformed if exposed in the sun for a long time.

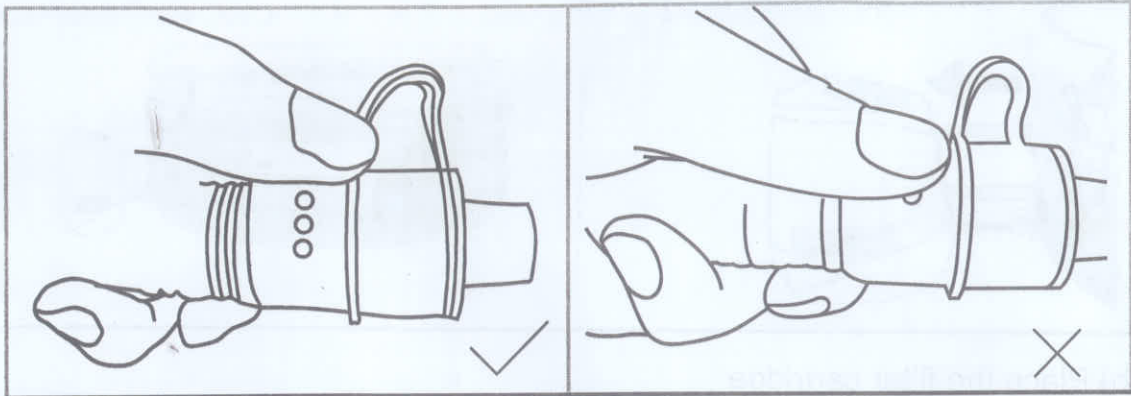

**CAUTION:** Do not press the air drainage hole on pump hose adaptor when inflation.

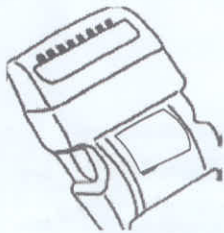

**ADVICE:** If your pool is setting up in a high temperature like outdoor in the sun, please deflate a bit to reduce the air pressure of the pool tube to avoid deform.

And then, inflate the top lid only until firm and supportive, Last, place the inflatable lid(A-2) into the SPA pool if your pool is Deluxe Style, and then close the fabric cover on pool and fasten all buckles



# SPA POOL SET UP INSTRUCTIONS

Press the small button, pull to open the buckle.

a) Now, it's time to connect the SPA pump to the pool: attach adaptors of pump with filtering  heating , bubbling  adaptors on the pool

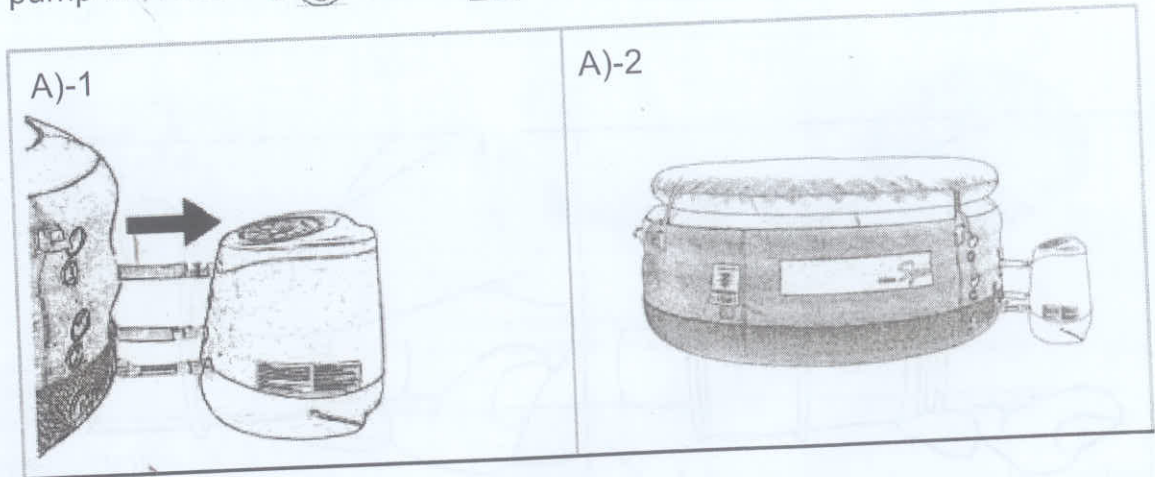

b) Place the filter cartridge  
Open the cartridge lid by counter-clockwise. Then put the new filter cartridge into the pump. Then screw the pump top lid clockwise. (Refer to below illustration)

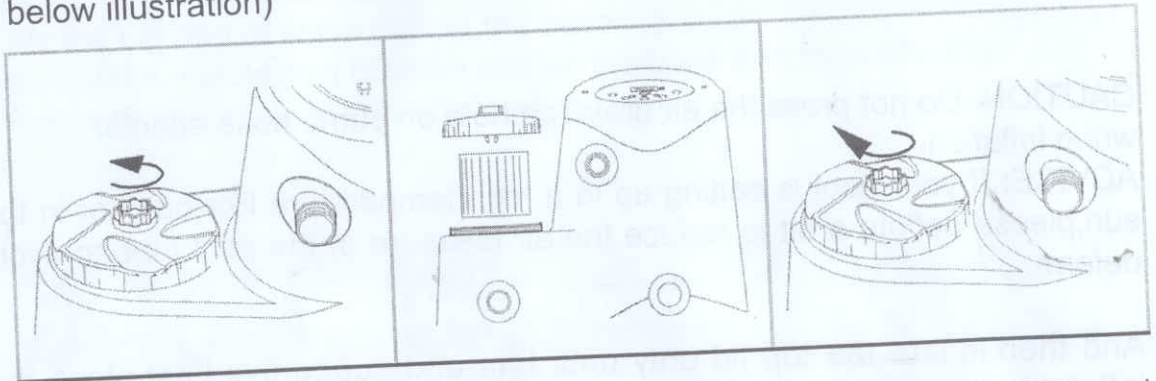

c) Pool is ready to fill water. Using your garden hose to fill the SPA pool until reaching minimum water level printed on pool inner wall.

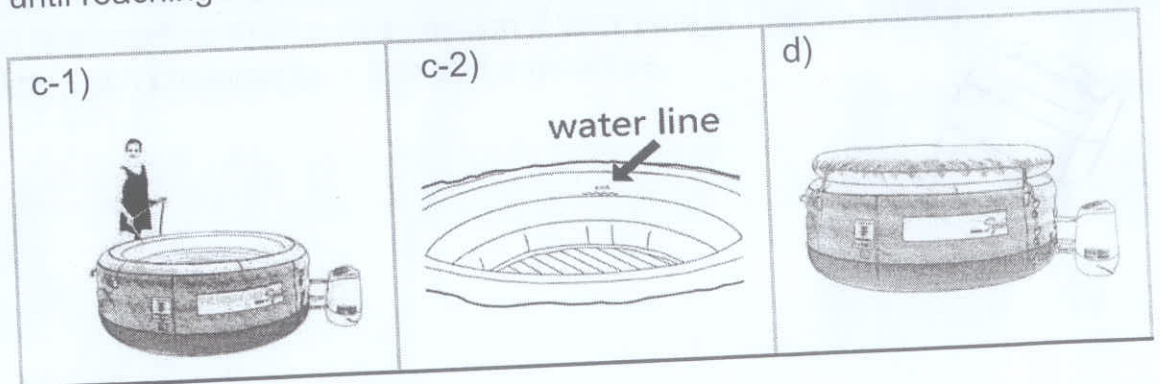

## SPA POOL SET UP INSTRUCTIONS

**WARNING:** Make sure the pump is unplugged before filling water

d) Before heating, place and lock the top lid to the SPA pool by using the digital lock on the top lid.

**WARNING:** Children is always attracted by water; Always lock the top lid after each use.

**WARNING:** Adult supervision is required for children around the SPA pool at all time. The cover is not a substitute for adult supervision;

## SPA PUMP OPERATION INSTRUCTIONS

### 1. RELEASE THE AIR INSIDE THE PUMP

**WARNING:** Never run the pump idly. Release the air inside the pump is the key step to ensure the pump running normally

**WARNING:** The water in the SPA pool must reach minimum water level printed on pool inner wall.

- 1) Unscrew the air purge valve counter-clockwise until the water is emerged.
- 2) Then close the air purge valve by clockwise turn.
- 3) Dry any excessive water on the pump body.

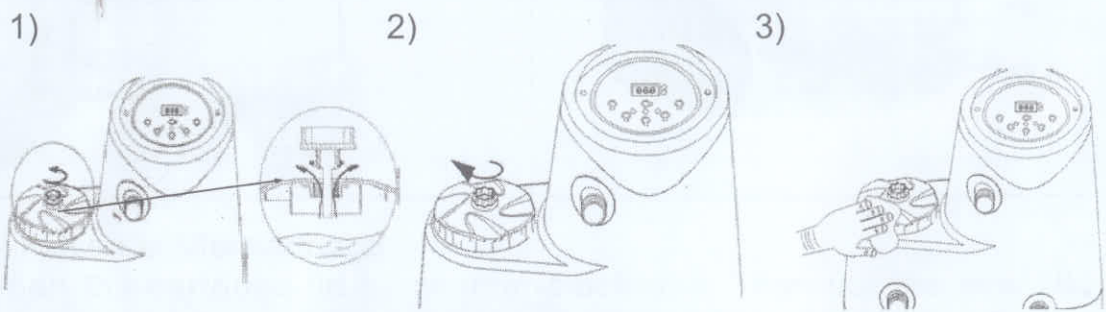

### 2. FUNCTIONS OF SPA PUMP

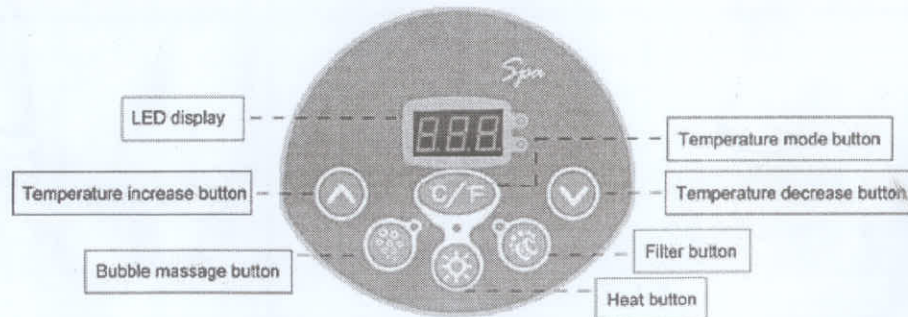

- 1) **888** LED Display: Once powered-up, the LED displays the current water temperature automatically.

**Note: If pressing is valid, you can hear buzzer and relative indicator light will turn on .**





- 2) **▲▼** Temperature Adjustment buttons: Increase **▲** Decrease **▼**
  - Press the temperature adjustment buttons, then the LED will flash. When it is flashing, you can set the desired temperature. The value will increase or decrease 1°C by once. If you hold the button for 2 seconds, the values will rapidly increase

**Temperature adjustment ranges:**

- **Celsius mode: 30°C - 40°C**

## SPA PUMP OPERATION INSTRUCTIONS

- Fahrenheit mode: 86 °F -104 °F

To lock the control panel, press  +  at same time and hold 3 seconds. Please lock the control panel during your leave to avoid others change your set model. Unlock the control panel by pressing  +  at same time and hold 3 seconds again.



3)  "Temperature Mode" button: Press the button to exchange Celsius mode and Fahrenheit mode



4)  "Bubble Massage" button: Activates bubble massage system

Press this button to activate the massage system, the green indicator light turns on. It can be turned off by pressing it again.

Note:

a) The massage system will stop automatically after 30 minutes of operation. Re-activate the massage function by pressing the massage button again.



b) When  is on, pressing  light will turn off and massage indicator light turn on. If press the  again, the massage mode will be changed back to filter mode.



c) Heating and Massage function can not be activated at same time. When heating system is working, pressing  will exchange heating mode into massage mode: heating and filtering are shut down, massage system will be activated. If press  again, heating and filtering will re-start.

5)  Activates Filter system This button turns the filter pump on and off. The green indicator light will turn on when the filtration system is activated

Note:

·when heating and filter function work at same time, pressing  may shut down heating and filtering together.

·when  is on, filter and heating can not be activated, You should shut down  firstly.



6) : Activates Heating and Filtering system at the same time Press  to activates Heating and Filtering system at the same time: the green indicator light of filter and red indicator light of heating will turn on at same time.

## SPA PUMP OPERATION INSTRUCTIONS

The pump does not stop heating until the current water temperature reaches the set temperature; and the heating system will restart after the current water temperature drops 2 °C below the set temperature automatically.

Heating Rate : approximately 2°C /hour. Max. heat temperature: 40°C (104 °F )

### NOTE:

- If the heat system is activated, the filtration system will automatically start, This is normal!
- After turning off the heat system, the filtration system will still work. This is normal.
- when bubble function is on, pressing  or  can not activate them.

### 3 DRAINAGE

- 1) Turn off all the buttons on the control panel and unplug the appliance.
- 2) Connect drain pipe on the bottom of SPA with a long hose, place another end of hose to drainage area. (picture 1)
- 3) Open the drain valve on the bottom of SPA pool. (picture2)

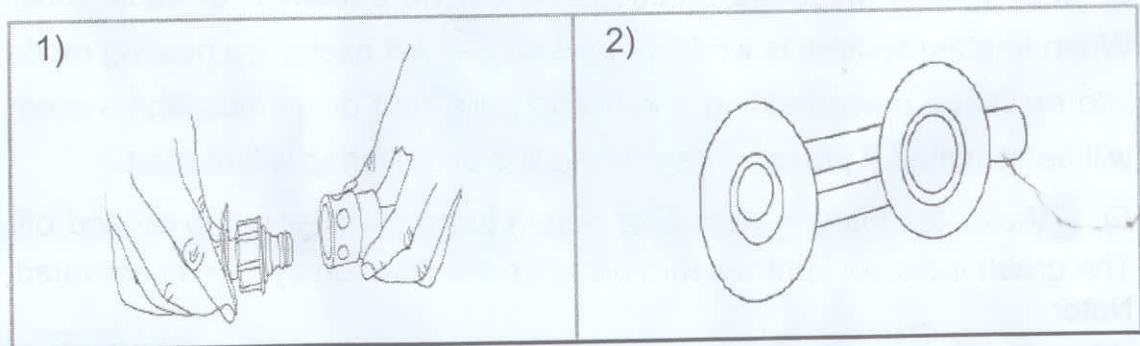

- 4) Recommend to use "Bubble Function" to blow out water from the "Bubble pipe" on inner wall.
- 5) Unplug the pump, disassembly all adapters, Remove the filter cartridge from pump house and dry the pump completely by draining all water from pump body and pipes.



## SPA PUMP OPERATION INSTRUCTIONS

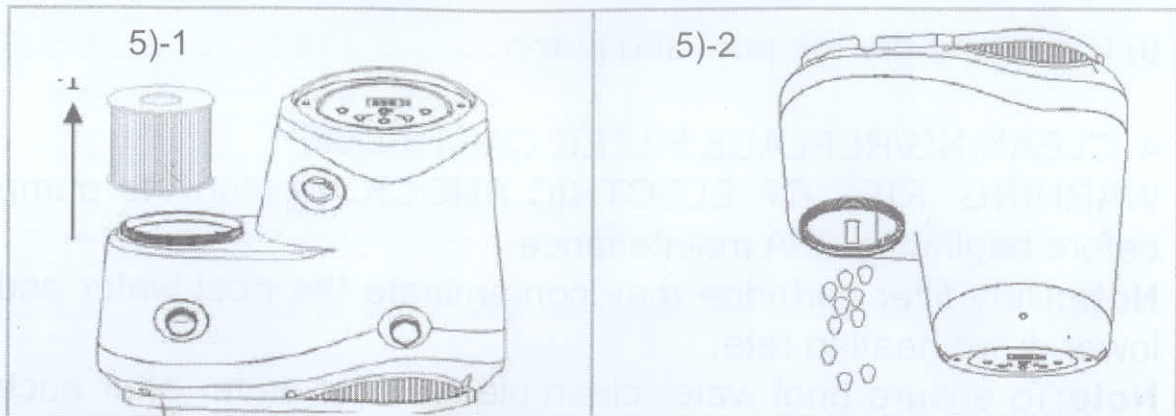

6) Open the drain valve on the bottom of pump, let the water flow out completely.

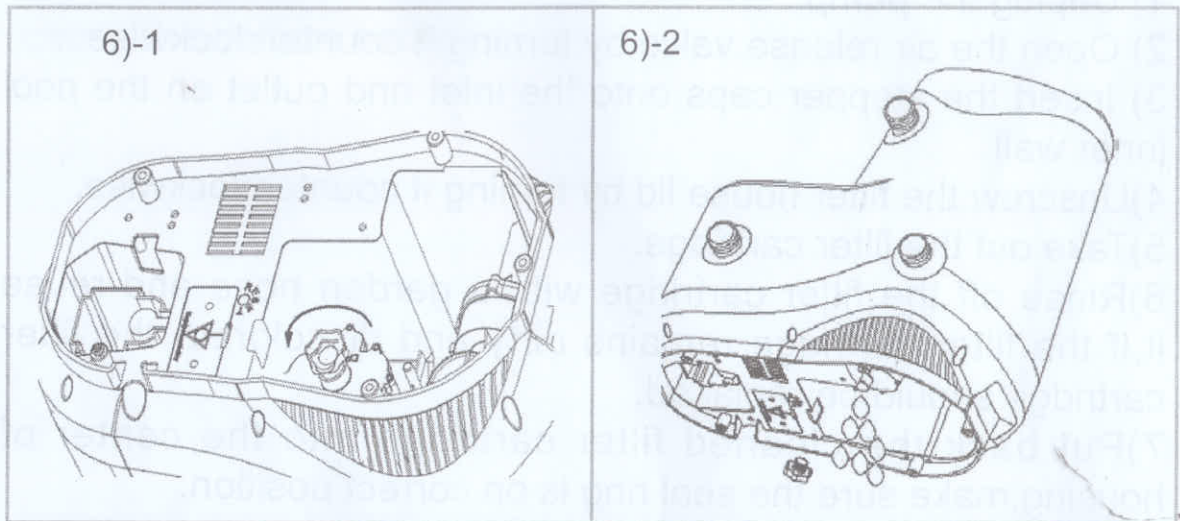

7) Refer to 7-1 /7-2 we recommend to use "Bubble function" to blow out water from pump. Then unplug the pump and tight the drain valve.

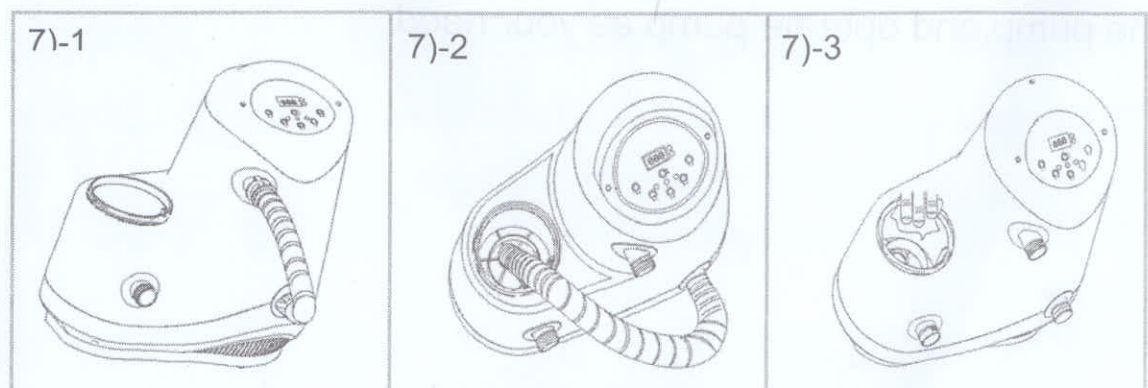

## SPA PUMP OPERATION INSTRUCTIONS

9) Clean and dry the pool and pump.

### 4. CLEANING/REPLACE FILTER CARTRIDGE

**WARNING: RISK OF ELECTRIC SHOCK.** Unplug the pump before beginning SPA maintenance.

**Note:** Dirty filter cartridge may contaminate the pool water and lower down heating rate.

**Note:** To ensure pool water clean, please filter water after each use, Clean the filter cartridge every day and replaced 3 days depending on use.

1) Unplug the pump.

2) Open the air release valve by turning it counterclockwise.

3) Insert the stopper caps onto the inlet and outlet on the pool inner wall.

4) Unscrew the filter house lid by turning it counterclockwise.

5) Take out the filter cartridge.

6) Rinse off the filter cartridge with a garden hose and reuse it, If the filter cartridge remains dirty and discolored, the filter cartridge should be replaced.

7) Put back the cleaned filter cartridge into the center of housing, make sure the seal ring is on correct position.

8) Close the lid by turning clockwise.

9) Remove the stopper caps from inlet and outlet on the pool inner wall, allow the water to flow into pump.

10) Repeat previously outlined steps: Do RCD test, release air in the pump, and operate pump as your need.

## SPA PUMP OPERATION INSTRUCTIONS

Style	Supra		Classic		Deluxe	
Item#	JL017145NG JL017145NE JL017145NU	JL017145NN	JL017144NG JL017144NE JL017144NAU	JL017144N N	JL017146N G JL017146N E JL017146N AU	JL017146NN
*Heating rate	2°C-4°C (3.6°F-7.2°F)/Hr	2oC-3oC (3.6oF-5.4oF)/Hr	2°C-3°C (3.6°F-5.4°F)/Hr	1oC-2oC (1.8oF-3.6oF)/Hr	2°C-3°C (3.6°F-5.4°F)/Hr	1oC-2oC (1.8oF-3.6oF)/Hr

\*Environment temperature of indoor is around 23°C(73.4°F).

The heating rate in above sheet are only for reference. Final effect will be changed according to different factors like environment temperature,

water volume, method of keeping warm, etc.

During start up and initial assembly, depending on the outside temperature, it will take up to 20 hours to heat up your spa to a comfortable temperature.

SPA cannot be used in negative outside temperature.

### Caution!

Filling the hot water into SPA pool is prohibited because over-high temperature water will damage the PVC material and cause the deform badly.

## MAINTENANCE SPA

### 1. SPA water treatment

Note: Pool quality can harm your health. We recommend you to maintain SPA water as below:

1) The filter cartridge should be cleaned every day and replaced 2-6 weeks depending on use.

2) Change water every 7 days or 14 days and use appropriate pool chemicals after each usage.

3) The application of chemicals will stop the growth of harmful bacteria or algae in your pool, and assist your filter-pump in keeping your water crystal clear. Please consult your local pool supply retailer for more information about chemical maintenance. Pay close attention to the chemical manufacturer's instructions. SPA damage resulting from misuse of chemicals and mismanagement of SPA water is not covered by the warranty.

**WARNING:** Do not use the SPA during disinfecting!

Do not use the chlorine chemical, it can corrupt the temperature system.

Pay close attention to the chemical manufacturer's instructions!

#### a) Water Balance

We recommend maintain your water balance as below:

**PH value: 6.5 - 8.5; Total alkalinity: 80 - 120ppm; Free chlorine: 3ppm - 5ppm**

Purchase a test kit to test your water chemistry Value before each use of the SPA, at least once per week. Low PH value will damage the pool and the pump. Damage resulting from chemical imbalance is not covered by the warranty.

#### b) Water Sanitation

The SPA owner should do water sanitation regularly (daily, if necessary). The sanitizer will chemically control the bacteria and viruses in the filled water or introduced during use of the SPA. Pool chemical maintenance

## MAINTENANCE SPA

We suggest to use BROMINE tablet with our chemical floater to disinfect the pool's water.(Chemical floater should be purchased separately)

- 1)Open the lid of chemical floater and put some pieces of BROMINE tablets in it(Do not exceed 20pieces)
- 2)Close the lid and put the floater into the SPA pool.
- 3) We suggest you to activate the bubble function while water is being disinfection in the pool, it is useful to let water circulate and disinfect the microorganism completely. Please see below illustration:

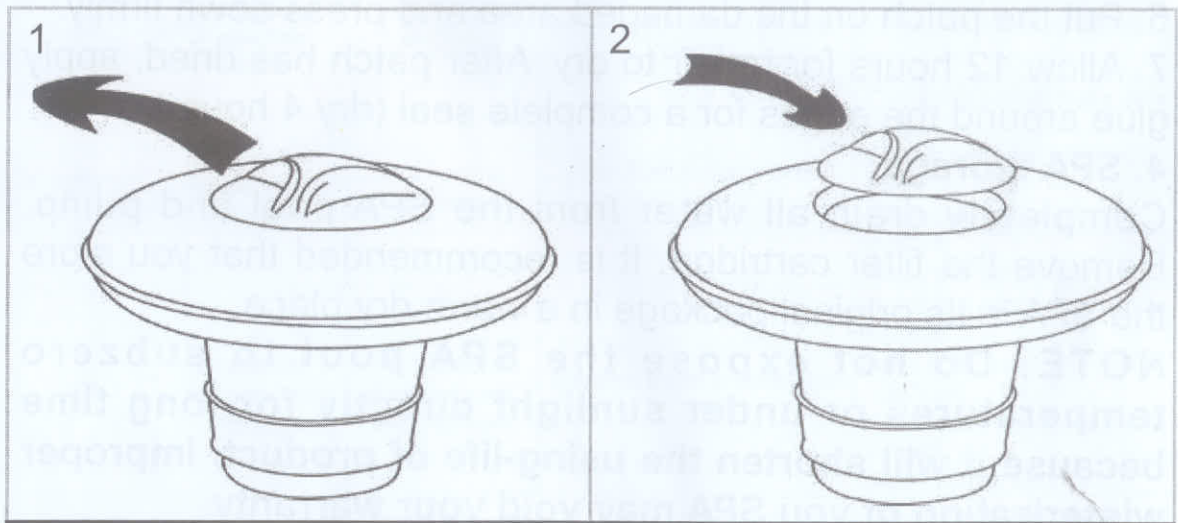

### 2. Cleaning the SPA

Clean the SPA pool with soap and water, then rinse. Leave it in shady and cool place for airing.

**NOTE: DO NOT use hard brushes or abrasive cleaners. Do not use the alkali or acid detergent to clean product! To avoid E7 trouble, please clean the inside water mouth(inlet and outlet) of the SPA pool to wipe off any dirt before and after each use!**

**3. REPAIRS (Little holes or puncture can be repaired with the repair kit come along with the SPA)**

## MAINTENANCE SPA

1. Find the leak.
2. Thoroughly clean the area surrounding the leak to remove any dirt or grime.
3. Cut a piece of repair material in round shape, which should be larger than the damaged area.
4. Using a piece of the repair kit, trace outline of the patch lightly.
5. Apply adhesive to the underneath side of the patch and around the area to be repaired. Coat the affected area lightly but completely with glue.
6. Put the patch on the damaged area and press down firmly.
7. Allow 12 hours for repair to dry. After patch has dried, apply glue around the edges for a complete seal (dry 4 hours)

### 4. SPA storage

Completely drain all water from the SPA pool and pump. Remove the filter cartridge. It is recommended that you store the SPA in its original package in a warm dry place.

**NOTE: Do not expose the SPA pool to subzero temperatures or under sunlight directly for long time because it will shorten the using-life of product. Improper winterization of you SPA may void your warranty**

## TROUBLE SHOOTING

Jilong aims to provide trouble-free SPA. If you experience any problem, do not hesitate to contact your local dealer or our after sales service. Here are some useful tips to help you to diagnose and rectify common sources of trouble.

1) Error Code: When LED displays the below error code, please check the below reference list.

CODE	PROBLEM	PROBLEM	CAUSES	SOLUTIONS
E1	Wrong temperature control sensor	Not heating properly	Temperature control sensor short circuit or open circuit.	Need qualified electrician
E2	Wrong temperature Protection sensor	Not heating properly	Temperature Protection sensor short circuit or open circuit.	Need qualified electrician
E3	High water temperature indicator	Not heating properly	The filled water is over 45°C(113°F)	<ul style="list-style-type: none"> <li>·Cutoff the power, make sure the pool water is between 2°C ~ 44°C (36°F ~ 111°F)</li> <li>·If t his does not s olve the problem, please call for service</li> </ul>
E4	Low water temperature indicator	All functions does not work, buzzing warn	The pool water is lower than 2°C(36°F)	<ul style="list-style-type: none"> <li>·Cutoff the power, make sure the pool water is between 2°C ~ 44°C (36°F ~ 111°F)</li> <li>·If t his does not s olve the problem, please call for service</li> </ul>
E5	High water temperature indicator	All functions do not work, buzzing warn	The filled water is over 50°C(122°F)	<ul style="list-style-type: none"> <li>·Cut off the power,turn to qualified electrician to re-set the thermal cutout described in next paragraph</li> <li>·If this does not solve the problem,please call for service</li> </ul>
E6	Water pressure is not big enough to activate heating	Not heating and filtering properly. Buzzing warns	<ul style="list-style-type: none"> <li>·Inlet or outlet on inner wall are blocked</li> <li>·Filter cartridge is too dirty</li> <li>·Pool water does not reach minimum water level</li> <li>·Do not release air from pump Pump is wrong</li> </ul>	<ul style="list-style-type: none"> <li>·Clean inlet and outlet</li> <li>·Clean or replace filter cartridge</li> <li>·Add water to reach min. water level</li> <li>·Do air release as outlined again</li> <li>·If this does not solve the problem, pls contact us</li> </ul>
E7	Dry-run heater	All functions do not work, buzzing warn	heating at no water situation,system shut down automatically	Need qualified electrician

2) E5 error solution-Reset thermal cutout

## TROUBLE SHOOTING

- (1) Cutoff power of pump
- (2) Insert the stopper caps onto the inlet and outlet on the pool inner wall
- (3) Disassemble pump, turn over the pump.

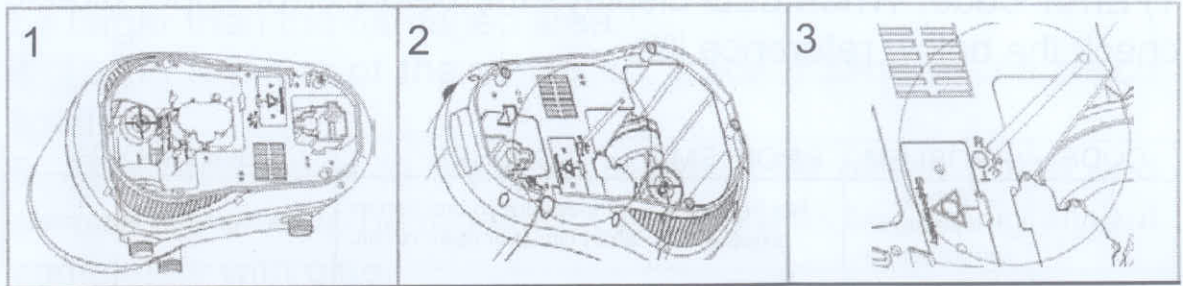

- (4) Locate the small hole marked "reset" on the bottom of pump. Then, inset a small stick (It should be less than  $\text{Ø}0.9\text{cm}$ , length is longer than 10cm) into the hole, press down, you can hear "ping", the reset is successful.
- (5) Then, connect pump with pool again. Take off the stopper on the inner pool and repeat the previous outlined steps to use your SPA.



## FREQUENT PROBLEMS SOLUTION

Problems	Causes	Solutions
SPA pump does not operate	<ul style="list-style-type: none"> <li>Power failure</li> <li>RCD tripped</li> <li>RCD broken</li> </ul>	<ul style="list-style-type: none"> <li>Check power source</li> <li>Reset RCD/check if the wiring system is too thin to afford 2000W or 10A</li> <li>Call for service if it does not reset</li> </ul>
SPA pump does not heat properly	<ul style="list-style-type: none"> <li>Temperature set is too low</li> <li>Filter Cartridge is dirty</li> <li>Too low water levels</li> <li>Heating element failed</li> </ul>	<ul style="list-style-type: none"> <li>Set to a higher temperature</li> <li>Clean/replace the filter cartridge</li> <li>Fill more water to min. water level</li> <li>Call for service</li> </ul>
Bubble massage system does not work	<ul style="list-style-type: none"> <li>Pump is too hot</li> <li>30-minute auto shut off feature is activated</li> <li>Something is wrong with the control panel</li> </ul>	<ul style="list-style-type: none"> <li>Cut off the power. When the pump has cooled, inset the plug and press the bubble button to activate again.</li> <li>Press the bubble button to reactivate</li> <li>Call for service if it does not reset</li> </ul>
Water filtration is not working	<ul style="list-style-type: none"> <li>Dirty filter cartridge</li> <li>Inlet and outlet blocked</li> <li>Do not release the air inside of pump</li> <li>Something is wrong with the control panel</li> </ul>	<ul style="list-style-type: none"> <li>Clean/replace the filter cartridge</li> <li>Clean the inlet and outlet</li> <li>Release the air as outlined steps</li> <li>Call for service if it does not reset</li> </ul>
Pump leakage	<ul style="list-style-type: none"> <li>Adaptor seal improperly</li> <li>Water leakage from pump body</li> </ul>	<ul style="list-style-type: none"> <li>Replace the seal in the right position</li> <li>Check the pump body, call for service</li> </ul>
Spa pool leakage	<ul style="list-style-type: none"> <li>Spa pool is torn or punctured</li> </ul>	<ul style="list-style-type: none"> <li>Use provided repair patch as previous outlined</li> </ul>
Water is not clean	<ul style="list-style-type: none"> <li>Insufficient filtering time</li> <li>Dirty filter cartridge</li> <li>Poor filled water quality</li> <li>Improper water treatment</li> </ul>	<ul style="list-style-type: none"> <li>Do filtration longer and frequently</li> <li>Clean/replace the filter cartridge</li> <li>Change the pool water completely</li> <li>Refer to the chemical manufacture's instructions.</li> </ul>



### RECYCLING

Meaning of crossed –out wheeled dustbin: Do not dispose of electrical appliances as unsorted municipal waste, use separate collection facilities. Contact your local government for information regarding the collection systems available. If electrical appliances are disposed of landfills or dumps, hazardous substances can leak into the groundwater and get into the food chain, damaging your health and well-being. When replacing old appliances with new ones, the retailer is legally obligated to take back your old appliance for disposals at least free of charge. This product bears the selective sorting symbol for waste electrical and electronic equipment

## FREQUENT PROBLEMS SOLUTION

(WEEE). This means that this product must be handled pursuant to European Directive 2002/96/ EC in order to be recycled or dismantled to minimize its impact on the environment. For further information, please contact your local or regional authorities. Electronic products not included in the selective sorting process are potentially dangerous for the environment and human health due to the presence of hazardous substances.

## LIMITED WARRANTY

**ATTENTION CUSTOMER** - Please read this statement carefully and keep your original store receipt along with this warranty certificate all the time. Your receipt is required as proof of purchase and to verify the length of your pool ownership.

We warrant all components contained in this Prompt Set™ Pool/SPA Pool (excluding the filter pump unit\*) against defects in materials and workmanship under normal use and service, for a period of 90 days (365 days\*) from the date of purchase for the original owner only.

If any of the components have been consumer-replaced, damaged, or misused, the corresponding warranty on those components is invalidated. In this situation, you will be advised of the cost of replacement parts and processing instructions.

If a verifiable manufacturing defect is found during the relevant time period, we agree to repair or replace at its option any product under warranty provided proper proof of purchase is presented.

This limited warranty is not valid if the product is used for commercial purposes, or if the damage is caused by an accident, an act of God, consumer misuse, neglect or abuse, vandalism, improper use of chemicals, exposure to extreme weather conditions or negligence during product set up or disassembly.

We cannot be held responsible for the cost of installation, labor, or transportation expenses incurred due to the replacement of defective parts. This limited warranty, furthermore, does not cover any unauthorized alterations to the product. In order to submit a claim, kindly please fill in all the parts of this form and send it by email or fax, attaching a copy of the receipt, the description of the problem and two photographs (as explained below, see the step #4). Jilong® is not responsible for any expenditure on the purchase of chemical products, wasted water, neither any consequences of water leakage. The warranty is not valid when defects are not caused by the producer.



# LIMITED WARRANTY CARD

## Step #1

Surname		Name	
Address			
Postal Code		Country	
Telephone		Mobile phone	
E-mail		Fax	
Retailer		Purchasing date	

## Step #2

Please find out and tick the product from the following list:

			
(EU) <input type="checkbox"/> JL017132NG	(NA) <input type="checkbox"/> JL017132NN	(EU) <input type="checkbox"/> JL017146NG	(NA) <input type="checkbox"/> JL017146NN
(UK) <input type="checkbox"/> JL017132NE	(AU) <input type="checkbox"/> JL017132NAU	(UK) <input type="checkbox"/> JL017146NE	(AU) <input type="checkbox"/> JL017146NAU
(EU) <input type="checkbox"/> JL017144NG	(NA) <input type="checkbox"/> JL017144NN	(EU) <input type="checkbox"/> JL017145NG	(NA) <input type="checkbox"/> JL017145NN
(UK) <input type="checkbox"/> JL017144NE	(AU) <input type="checkbox"/> JL017144NAU	(UK) <input type="checkbox"/> JL017145NE	(AU) <input type="checkbox"/> JL017145NAU

## Step #3

Problem:

Pool (water) leakage  Pump (water) leakage  Heating System not working  RCD/GFCI plug not working  Components Missing

Other: .....

Please describe the problem in details: .....

.....

.....

.....

.....

.....

.....

.....

## Step #4 – Photo

- One detailed photo of the problem
- One general photo of the set (for example: the pool with its surrounding)