

Next Generation

**MODEL #5007
ASSEMBLY MANUAL**



YOUR WARRANTY

Playground, Inc., dba Leisure Time Products, provides a 1-year limited warranty. See inside back cover of this manual for details.

We take great care to design our products with your child's safety in mind. However, only with careful supervision and proper safety instructions, can you be assured of safe play time on any product designed for children.

**Assembly requires
at least two adults.**

If you need assistance with parts or have assembly questions, please call Customer Service at

866-362-1123

Our regular office hours are
Monday through Friday, 7:00 a.m. to 4:00 p.m. Central Time

Please read the entire instruction manual carefully before proceeding with the assembly or use of your new gym set. **SAVE THIS MANUAL** for future reference in the event that you need to contact us for assistance or replacement part information and ordering.

LEISURE TIME PRODUCTS

For Residential Only

IMPORTANT TIPS FOR ASSEMBLY

Prior to assembling your play product, take a thorough inventory of all components using the parts list.

Sort and lay out all wood pieces, matching identical pieces into piles. Mark all pieces of wood using masking tape, write board letter on tape and adhere to each piece of wood for quick reference and identification.

Sort all hardware according to size. Refer to parts identification section. Selecting the wrong hardware during early assembly will lead to shortages. Finding extra hardware is not cause for alarm. We often include extra hardware in case parts are lost during assembly.

Selecting the correct location for your playset product is very important for your children's safety and for the play product's longevity. Your playset must be installed on level ground. Installation on sloping ground will cause your set to "lean" and, in time, this leaning will put stress on all the joints. This stress will cause the set to become loose and unstable. Once this occurs, it becomes difficult to correct, and Playground, Inc. cannot assume responsibility for any failure from incorrect installation. Uneven ground must be properly leveled before installation.

Warping: Occasionally, some wooden components may twist or warp in the carton after packaging. This is not necessarily a cause for alarm. In most instances, these parts straighten out when assembled. Seasonal checking or cracking of the grain on wooden parts is also quite natural. Water and heat are the two most frequent causes of expansion and contraction of wood fibers. We recommend that you apply a wood sealant or protectant at the time of

installation and at least once per year. There are many excellent products, such as Thompson's Waterseal, Behr Wood Conditioner, Olympic Water Guard or Olympic Wood Protector. Please check with your local home improvement center to see what they recommend for your area conditions. Proper care and maintenance will help maintain the beauty of the set as well as gain the maximum life of the unit.

Metal plates: The structural integrity of the play product is dependent upon the proper installation of the metal plates. As noted and diagramed in these assembly instructions, the installation of these metal plates must also be followed precisely. If your play set has end ladders or swing beam supports, make sure they are angled away from the top ladder or swing beam. If a play product has one or two climbing towers, the metal plates must be installed so that each climbing tower is perpendicular to the top ladder.

Ground stakes: Metal stakes are provided and are to be installed as outlined in the assembly manual. Cementing is recommended and required if you have loose or sandy soil or if you live in an area that is prone to high winds or severe storms.

On site adult supervision is required at all times for children of all ages.

Ensure that suspended climbing ropes, chains or cables are kept tight enough so they cannot be looped back on themselves and are kept secure at both ends.

SEE PAGES 34 THRU 36 FOR MAINTENANCE TIPS

SAFETY AND ASSEMBLY INFORMATION

FOR SAFETY'S SAKE,
PLEASE TAKE TIME TO READ ALL INSTRUCTIONS COMPLETELY
AND CAUTION YOUR CHILDREN ACCORDINGLY

Caution for Your Children. Observing the following statements and warnings reduces the likelihood of serious or fatal injury.

- Instruct children not to attach items to the swing set that are not specifically designed for or made to use on the equipment (such as jump ropes, clotheslines, pet leashes, cables, or chains) as this could pose a strangulation hazard.
- Children should use equipment only in its intended manner.
- Children should sit in the center of the swings with their full weight on the seats. Only one child per swing.
- Children should NOT wear loose or stringed clothing or jewelry which can cause a potential danger of strangulation while using playground equipment.
- Children should NOT play on equipment in wet weather conditions due to potentially slippery surfaces.
- Children should NOT walk too closely in front of, behind, or between moving elements such as swings, trapezes and gliders.
- Children should NOT swing empty swing elements.
- Children should NOT jump off swings and/or trapeze while they are in motion. Nor should they jump from the upper decks – always use the ladders or slides.
- Children should NOT climb UP the slide because the slick surface could cause a fall and they should never slide down head first.
- Children should NOT twist swing chains or loop them over the top support beam because this will weaken and reduce the strength of the chain and possibly break them.
- Children should NOT climb on the top ladder when swing elements are in use.
- If your set has a Climbing Rope, the Climbing Rope must be attached securely at both ends in such a manor that it can not be looped back upon itself.

WARNING

Small components of your play center represent a choking hazard to children. Do not allow access to nuts, bolts, washers or other small parts. Tighten and inspect your play center frequently to avoid this danger.

Children must not use equipment until properly installed. Before using your play center, carefully read to any and all children who may use the play center the "safety rules" included in this booklet.

Play center modification is forbidden. Any modifications to your play center will affect its structural integrity and render the warranty null and void.

Caution! This play product will not be ready for a child's play until assembly procedures are complete, all hardware is tightened, all ground stakes are installed, and you, the responsible adult, are satisfied that the unit is secure and safe. At this time and always, review the "safety and general information - cautions for use" sections with each child using the play product.

SAFETY AND ASSEMBLY INFORMATION

Tools and Materials Required:

- | | |
|---|-----------------------------------|
| Claw Type Hammer | 10 ft. Tape Measure |
| Framing Square or Level | 10 ft. Step Ladder |
| Box Wrench or Sockets (9/16" & 1/2") | Screwdriver (Medium Phillips) |
| Electric Drill or Cordless | Beeswax or Soap |
| Drill Bits: 3/16", 3/8" 5/16" & 7/16"(High Speed) | (Used to lubricate screw threads) |

HAVING THE PROPER TOOLS ON HAND WILL EASE AND REDUCE THE ASSEMBLY TIME OF YOUR NEW PLAYSET.

Assembly Safety:

- Keep the work area clean and clear of obstructions.
- Children should stay out of the work area until the safe play area is cleared of obstacles, the gym set has been completely assembled, all hardware has been tightened and checked and all tools have been picked up.
- Keep children off the gym set until it has been completely assembled.
- Some parts of the assembly process may require help from another competent adult.
- Do not stand on the platform until the gym set has been completely assembled. Use a step ladder if you can not reach high enough.
- Follow the manufacturers' safety recommendations for the tools and equipment you use.
- Avoid assembling your gym set in poor weather conditions.

YOUR PLAYGROUND, INC READY-TO-ASSEMBLE PLAYSET IS STAINED AT OUR FACTORY. STAINING IS NOT NEEDED AT THE TIME OF INITIAL ASSEMBLY.

THE WOODEN PARTS FOR YOUR PLAYSET ARE MADE FROM CYPRESS AND OTHER UNTREATED NATURALLY DECAY RESISTANT LUMBER, WITH THE FOLLOWING, POSSIBLE EXCEPTIONS:

POLYETHYLENE ENCASED POSTS:

Some lumber inside the polyethylene encased posts MAYBE subject to the following treatment

- | | |
|------------------|---|
| Supplier: | Pacific Wood Preserving
22125 Rock Creek Rd.
Sheridan, OR 97378 |
| Preservative: | Pacbor Treated (Disodium Octaborate Tetrahydrate) |
| Retention level: | .118 pcf |
| Wood species: | Pine, White Fir, Hem Fir,
and/or Doug Fir |

SAFETY AND ASSEMBLY INFORMATION

SELECTING THE CORRECT LOCATION FOR YOUR PLAY PRODUCT IS IMPORTANT
FOR YOUR CHILDREN'S SAFETY AND THE PRODUCT'S LONGEVITY

Dimensions:

- The Next Generation has One layout option.

Layout	Ground Dimension	Safe Play Area*
	6'81/2"x5'10"	17'-10"x18'-9"

- *Level Ground Surface - See below
- Additional accessories may increase the size of the Safe Play Area.
- Max fall height 90"

General Information:

Your set has been designed and engineered for children only and for residential use only.
 A maximum of 150 lbs. per child is recommended for play activities designed for individual use.
 A maximum of 120 lbs. per child is recommended for play activities designed for multiple child use.
 A maximum of 9 children is recommended for this unit.

Safe Play Area:

- The safe play area refers to a zone extending 6' beyond the gym set on all sides, including the space above the gym set.
- The ground surface must be level. Installing your gym set on sloping ground can cause it to lean or "rack". This leaning puts additional stress on all connections and joints and in time will cause those connections to loosen and fail.
- The safe play area must be free of all structures, landscaping, trees and branches, rocks, wires, and other obstacles to safe play. Children can be seriously injured running or swinging into these obstacles.
- Remove all tripping hazards from the safe play area. Tripping hazards include: roots, stumps, rocks, landscaping, sprinkler heads, railroad ties, plumbing and electrical connections.
- Do not install your gym set over concrete, gravel, asphalt, packed earth or any other hard surface. The following is a list of recommended ground covers from the Consumer Product Safety Commission.

RECOMMENDED GROUND COVERS	
Suggested Material	Uncompressed Depth
Double Shredded Bark Mulch	9"
Uniform Wood Chips	12"
Fine Gravel	12"
Fine Sand	12"

A FALL ON TO A HARD SURFACE COULD RESULT IN SERIOUS INJURY

Any edging used to contain the ground must be beyond the safe play area.

(Ex. Landscape timbers or railroad ties)

Back

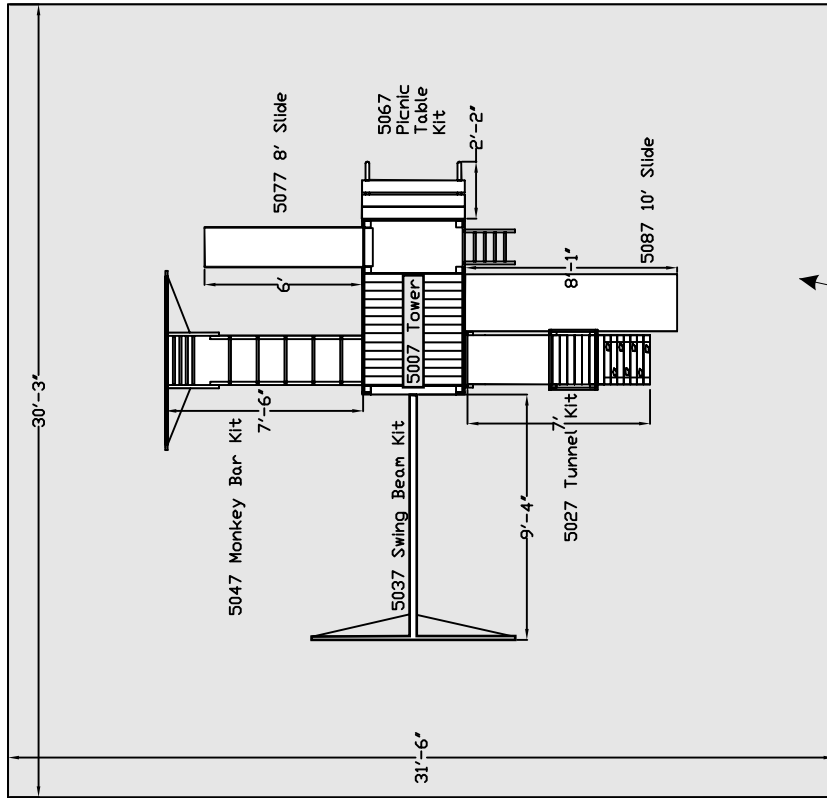

Left

Front

Right

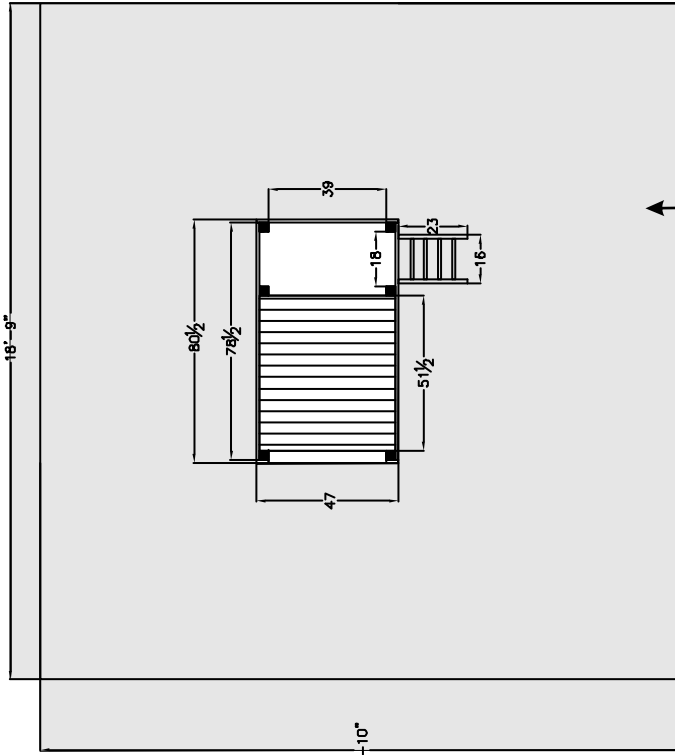

Landscape Timbers
6' from play structure

Sale play area using
recommended ground cover

Landscape Timbers
6' from play structure

Sale play area using
recommended ground cover

USING THE HARDWARE

PLAYGROUND, INC. GYM SETS USE A FEW STANDARD CONNECTIONS. BECOMING FAMILIAR WITH THESE CONNECTIONS WILL SIMPLIFY ASSEMBLY AND INSURE A SAFER PLAY PRODUCT FOR YOUR CHILDREN.

How to use Hex Head Bolts and Spike T-Nuts

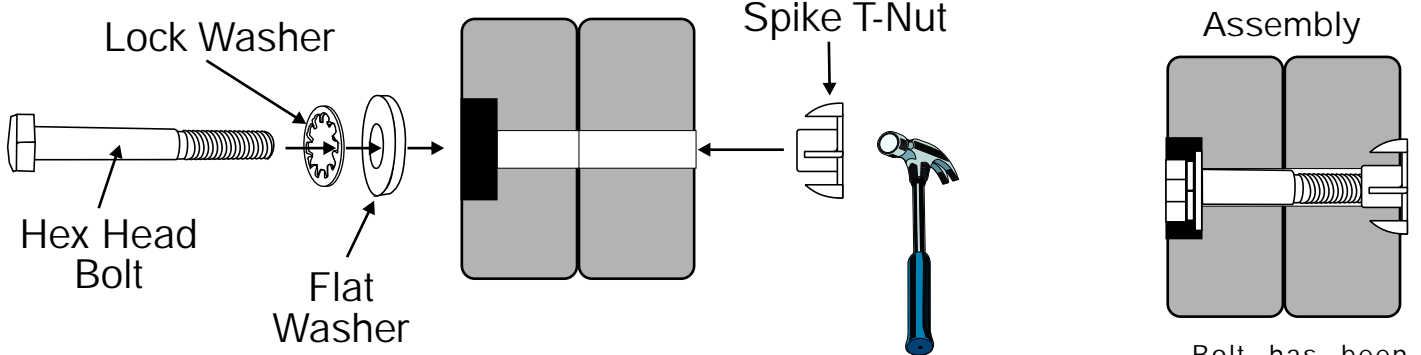

Check the positioning of parts in each Step's illustration, noting which of the parts should receive the Spike T-Nut. Place the Spike T-Nut in the hole and then seat it with one or two taps of a hammer. Align the holes in the parts to be fastened. Start preliminary tightening of bolt into seated nut by hand.

To *securely tighten*, turn the bolt with a wrench until the lock washer is fully compressed between the head of the bolt and the flat washer.

Note that in some steps the instructions say to tighten "*just snug*." This means to tighten the bolt just enough to keep the parts together, but loose enough to allow the parts to move. This is necessary to allow squaring and leveling. The bolt will be tightened securely in a following step.

TIP: Tap the Spike T-Nut into the part before you position the part on the structure. If you put it in the wrong hole, remove it by inserting a bolt from the opposite side of the board and tapping the bolt lightly with a hammer.

Bolt has been screwed securely into Spike T-Nut and the connection is tight.

Check connections periodically for tightness during the life of the Gym set.

Do not over tighten.

Incorrect Assembly

During assembly or maintenance, do not over tighten the bolts. Over tightening can cause the bolt to protrude past the spiked tee nut, which could cause personal injury. Over tightening can also cause the wood to be compressed or to "sink in" the bolt, washer or spiked tee nut. If this has happened, you may need to add additional washers or replace the bolt with a shorter one, so that the bolt does not protrude.

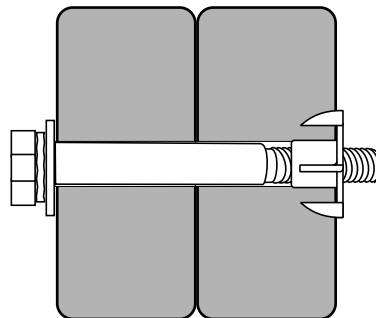

Failure to replace this bolt with a shorter one could result in personal injury.

Typical Installation -Lag Screw

- Always drill pilot holes when using Lag Screws. The size of the pilot hole will be specified in the Step.
- Tap the head of the Lag Screw with a hammer to start the threads into the wood and then use a 1/2" socket to tighten.

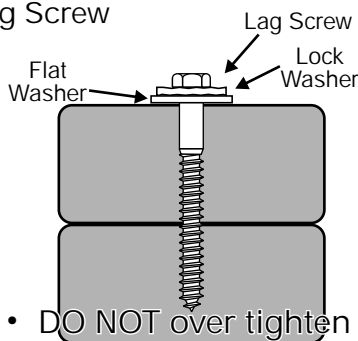

• DO NOT over tighten

Typical Installation -Wood Screw:

- Use an electric drill or screw gun to drive screws.
- These screws are self-tapping, so no pilot holes are required.
- Lubricate the threads of the screws with beeswax or soap to ease installation and minimize breaking screws.
- It is very important to make certain that the tops of all screws are flush with the surface of the wood and there are no protruding sharp edges.

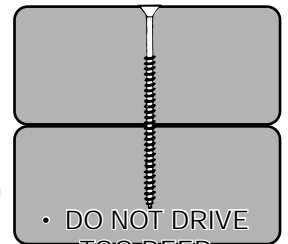

• DO NOT DRIVE TOO DEEP AND CAUSE SPLINTERING

NOT SHOWN

- H6
- H13
- H8
- G3
- H7
- H14
- L1
- G4
- L2

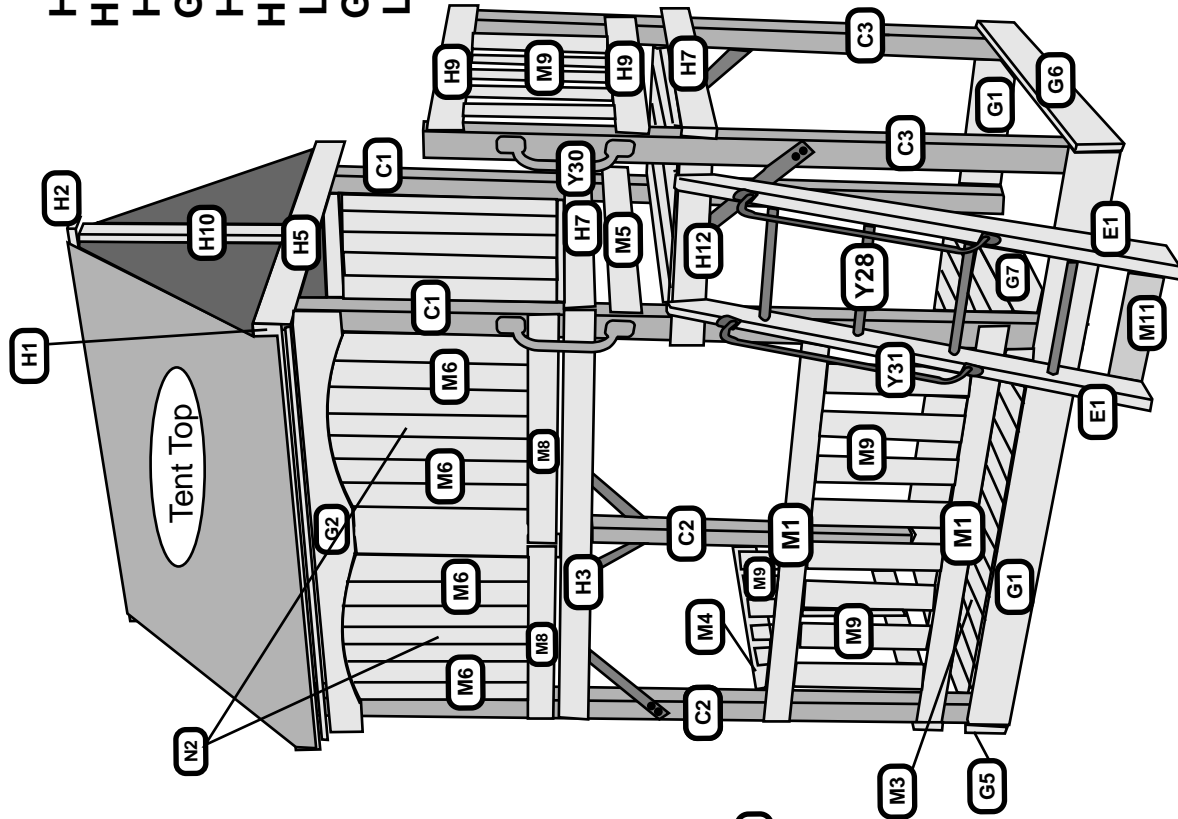

Front View

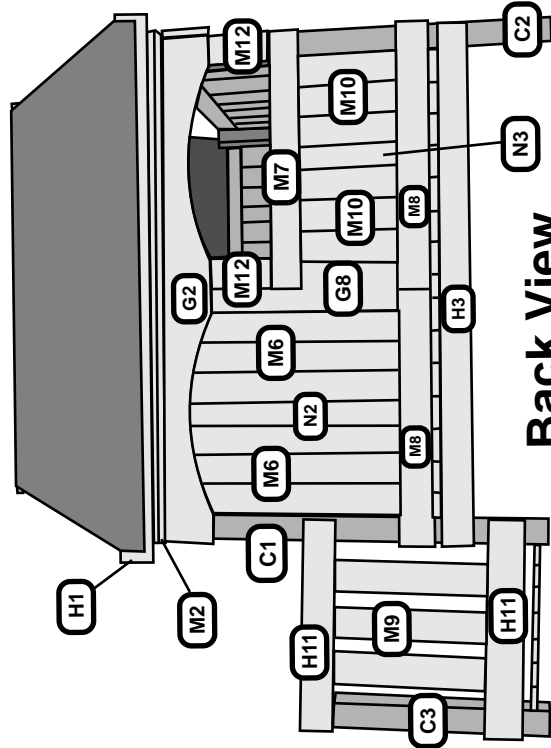

Back View

5007 Tower C1 - H9

C1 - TOWER LEG 2 REQUIRED

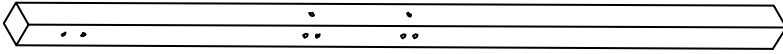

C2 - TOWER LEG 2 REQUIRED

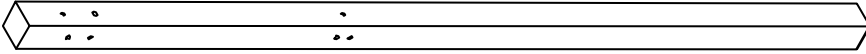

C3 - TOWER LEG 2 REQUIRED

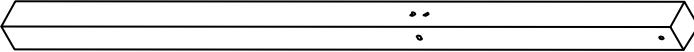

E1 Entry Ladder Rail * 4 Holes * 1 Set Left & Right Req
1 x 3/8 x 3-3/8 x 52 [2.54 x 8.57 x 132.08]

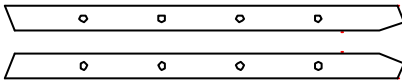

G2 Arched Wall Rail * 4 Holes * 2 Req
1 x 5-1/2 x 57-1/2 [2.54 x 13.97 x 146.05]



G4 Club House Wall Rail * 8 Holes * 1 Req
1 x 5-1/2 x 47 [2.54 x 13.97 x 119.38]



G6 Base Board * 4 Holes * 1 Req
1 x 5-1/2 x 47 [2.54 x 13.97 x 119.38]



G8 Club House Wall Support * 5 Holes * 2 Req
1 x 5-1/2 x 29 [2.54 x 13.97 x 73.66]

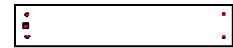

H2 Tent Support * 4 Holes * 1 Req
1 x 3-1/2 x 59-1/2 [2.54 x 8.89 x 151.13]

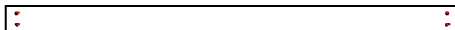

H4 Floor Joist * No Holes * 1 Req
1 x 3-1/2 x 57-1/2 [2.54 x 8.89 x 146.05]



H6 Floor Rail * 6 Holes * 1 Req
1 x 3-1/2 x 47 [2.54 x 8.89 x 119.38]



H8 Floor Rail * 4 Holes * 1 Req
1 x 3-1/2 x 45 [2.54 x 8.89 x 114.30]



G1 Base Board * 6 Holes * 2 Req
1 x 5-1/2 x 78-1/2 [2.54 x 13.97 x 199.39]

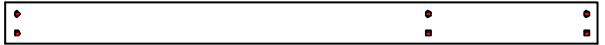

G3 Bottom Floor Joist * No Holes * 1 Req
1 x 5-1/2 x 53-1/2 [2.54 x 13.97 x 135.89]

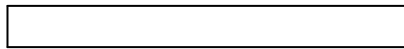

G5 Base Board * 6 Holes * 1 Req
1 x 5-1/2 x 47 [2.54 x 13.97 x 119.38]



G7 Base Board * 6 Holes * 1 Req
1 x 5-1/2 x 45 [2.54 x 13.97 x 114.30]



H1 Roof Support * 4 Holes * 2 Req
1 x 3-1/2 x 59-1/2 [2.54 x 8.89 x 151.13]

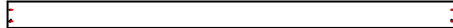

H3 Floor Rail * 5 Holes * 2 Req
1 x 3-1/2 x 57-1/2 [2.54 x 8.89 x 146.05]

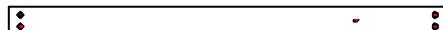

H5 Roof Support * 4 Holes * 2 Req
1 x 3-1/2 x 57 [2.54 x 8.89 x 144.78]



H7 Floor Rail * 4 Holes * 2 Req
1 x 3-1/2 x 47 [2.54 x 8.89 x 119.38]



H9 Wall Rail * 2 Holes * 2 Req
1 x 3-1/2 x 45 [2.54 x 8.89 x 114.30]

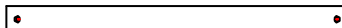

5007 Tower H10 - N3

H10 Upright * 2 Holes * 2 Req
1 x 3-1/2 x 29-1/2 [2.54 x 8.89 x 74.93]

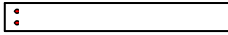

H12 Floor Rail * 7 Holes * 1 Req
1 x 3-1/2 x 24 [2.54 x 8.89 x 60.96]



H14 Floor Joist * No Holes * 1 Req
1 x 3-1/2 x 20 [2.54 x 8.89 x 50.80]

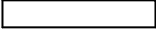

L2 Club House Wall Board * 4 Holes * 1 Req
11/16 x 4-1/2 x 29 [1.74 x 11.43 x 73.66]



M2 Roof Spacer * 3 Holes * 2 Req
11/16 x 3-3/8 x 57-1/2 [1.74 x 8.57 x 146.05]



M4 Wall Rail * 4 Holes * 2 Req
11/16 x 3-3/8 x 45-3/4 [1.74 x 8.57 x 116.21]

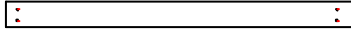

M6 Club House Wall Board * 4 Holes * 28 Req
11/16 x 3-3/8 x 29 [1.74 x 8.57 x 73.66]

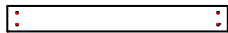

M8 Club House Rail * 3 Holes * 4 Req
11/16 x 3-3/8 x 28-3/4 [1.74 x 8.57 x 73.03]



M10 Club House Wall Board * 4 Holes * 6 Req
11/16 x 3-3/8 x 16 [1.74 x 8.57 x 40.64]



M12 Window Trim * 2 Holes * 2 Req
11/16 x 3-3/8 x 6-3/4 [1.74 x 8.57 x 17.15]



N2 Club House Wall Board * 2 Holes * 3 Req
11/16 x 2-1/2 x 29 [1.74 x 6.35 x 73.66]

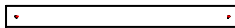

H11 Wall Rail * 4 Holes * 2 Req
1 x 3-1/2 x 25 [2.54 x 8.89 x 63.50]

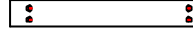

H13 Floor Rail * 5 Holes * 1 Req
1 x 3-1/2 x 24 [2.54 x 8.89 x 60.96]

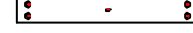

L1 Floor Board * 4 Holes * 4 Req
11/16 x 4-1/2 x 39 [1.74 x 11.43 x 99.06]

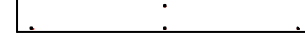

M1 Wall Rail * 4 Holes * 2 Req
11/16 x 3-3/8 x 57-1/2 [1.74 x 8.57 x 146.05]

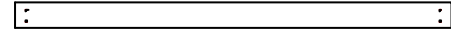

M3 Floor Board * 5 Holes * 34 Req
11/16 x 3-3/8 x 47 [1.74 x 8.57 x 119.38]



M5 Club House Rail * 4 Holes * 2 Req
11/16 x 3-3/8 x 45 [1.74 x 8.57 x 114.30]

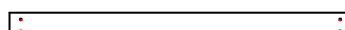

M7 Window Trim * 4 Holes * 1 Req
11/16 x 3-3/8 x 28-3/4 [1.74 x 8.57 x 73.03]

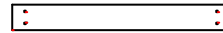

M9 Wall Board * 4 Holes * 23 Req
11/16 x 3-3/8 x 23 [1.74 x 8.57 x 58.42]

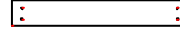

M11 Entry Ladder Support * 4 Holes * 1 Req
11/16 x 3-3/8 x 16 [1.74 x 8.57 x 40.64]

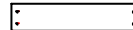

N1 Floor Board * 5 Holes * 1 Req
11/16 x 2-1/2 x 47 [1.74 x 6.35 x 119.38]



N3 Club House Wall Board * 2 Holes * 1 Req
11/16 x 2-1/2 x 16 [1.74 x 6.35 x 40.64]

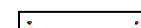

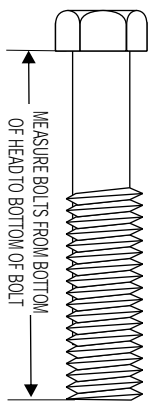
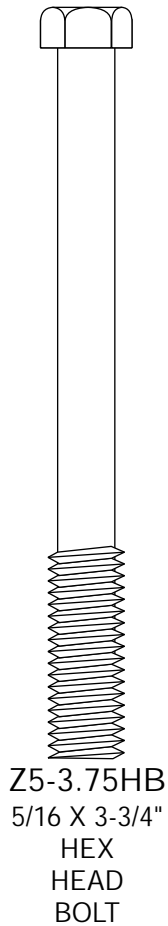

Z5-1.75HB
5/16 X 1 3/4"
HEX
HEAD
BOLT

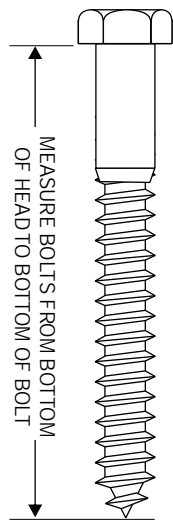
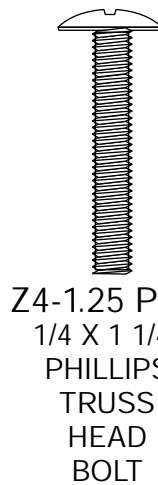
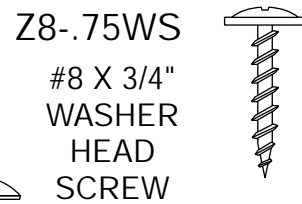
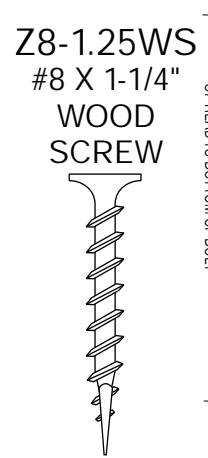
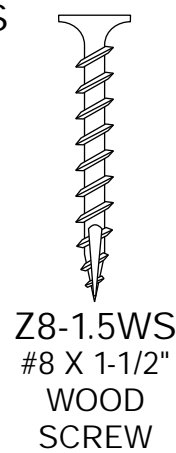
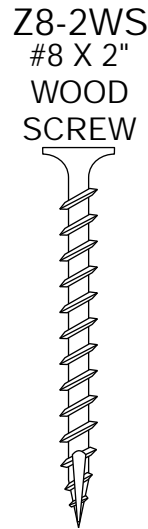
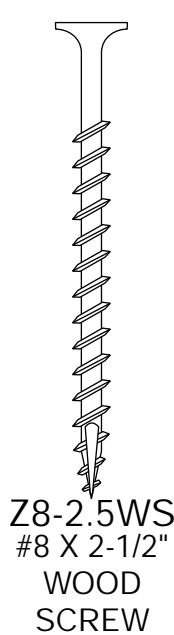
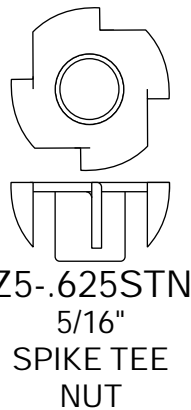
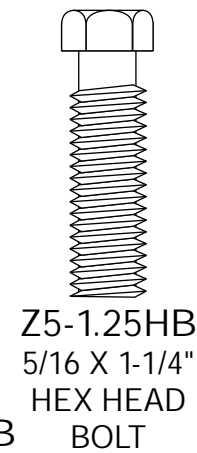

Z5-2.5LS
5/16 X 2-1/2"
LAG
SCREW

DRAWINGS ARE TO SCALE BUT
SMALL VARIATIONS ARE NORMAL.

Z5-3.5HB		
16 ths	Size	Type

- 3 - Z4-1SB STEP BOLT
- 3 - Z4-.75 PBN BARREL NUT

- 3 - Z5-.625 ITLW LOCK WASHER
- 3 - Z5-.75 FW FLAT WASHER

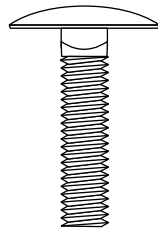

NOTE: Hardware Has Been Included To
Attach A Slide Which Is Purchased Separately.
Please Save This Hardware For Future Use

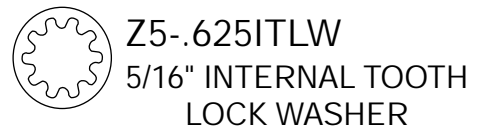

This hardware package was designed to work with many of our playsets so you will find extras of some of the parts. We suggest that you count out the proper numbers according to the list on Page 11 and take special care to note the sizes given in each step. See page 6 for proper installation instructions.

NOTE: QUANTITIES INCLUDE EXTRA HARDWARE

PART #	DESCRIPTION	TOTAL	BAG #
Z5-3.75HB	5/16-18 x 3 3/4" Hex Head Bolt	40	1
Z5-1.75HB	5/16-18 x 1 3/4" Hex Head Bolt	4	1
Z5-1.25HB	5/16-18 x 1 1/4" Hex Head Bolt	6	1
Z4-1.25PTH	1/4-20 x 1 1/4" Phillips Truss Head Bolt	4	2
Z4-1PTH	1/4-20 x 1" Phillips Truss Head Bolt	4	2
Z4-.75PTH	1/4-20 x 3/4" Phillips Truss Head Bolt	4	2
Z4-1SB	7/8" Head Diameter - 1/4-20 x 1" Step Bolt	3	2
Z8-.75WHS	#8 x 3/4" Modified Truss Washer Head Screw	15	2
Z4-.75PBN	1/4-20 x 3/4" LONG - Phillips Barrel Nut	17	2
Z5-2.5LS	5/16 x 2 1/2" Lag Screw	60	3
Z8-2.5WS	#8 x 2 1/2" Phillips Type 17 w/nibs Wood Screw	28	4
Z8-2WS	#8 x 2" Phillips Type 17 w/nibs Wood Screw	237	5
Z8-1.5WS	#8 x 1 1/2" Phillips Type 17 w/nibs Wood Screw	116	6
Z8-1.25WS	#8 x 1 1/4" Phillips Type 17 w/nibs Wood Screw	160	7
Z5-.625STN	5/16-18 x 5/8" LONG - Spiked Tee Nut	58	8
Z5-.75FW	5/16 SAE Flat Washer - 11/16"OD x 11/32" ID	132	9
Z5-.625ITLW	5/16 Internal Tooth Lock Washer - 19/32" OD	130	10

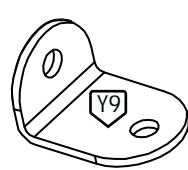
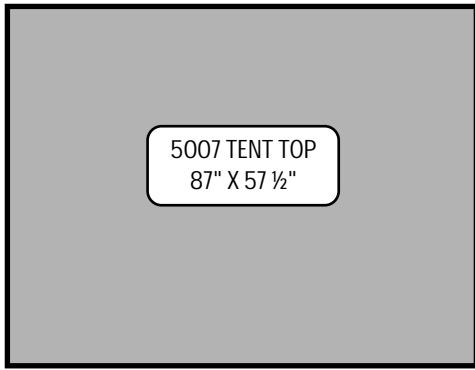
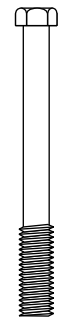
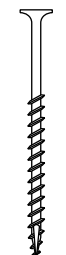

2" x 1" METAL BRACKET
2 REQUIRED

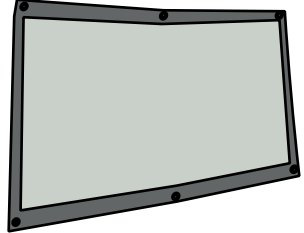

5007 GREEN MESH WINDOW
1 13x23



16 1/2" METAL GRIP
2 REQUIRED

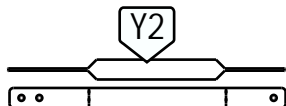

METAL DECK BRACE
6 REQUIRED



Plastic Cap
6 Required



35" METAL GRIP
2 REQUIRED

ADDITIONAL ITEMS

1 - METAL ID PLAQUE	4 - GROUND STAKES
1 - ASSEMBLY MANUAL	1 - POUNDING BLOCK
4 - Y28 15 1/4" METAL DOWELS	

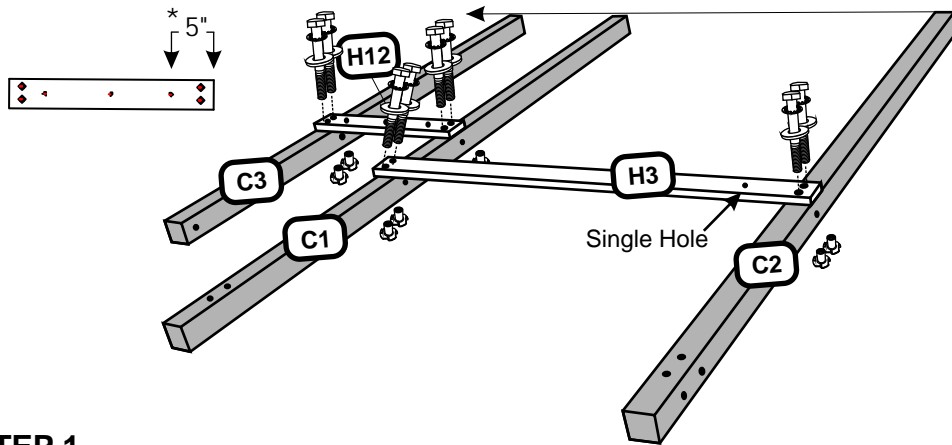
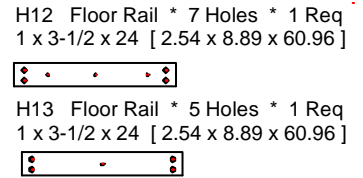
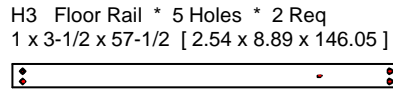
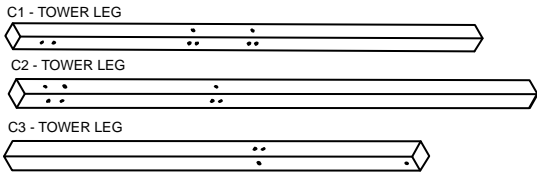

Note Flush Bottom of Posts

STEP 2

Install H12 Floor Rail, seven-hole, to C1 and C3 Posts using 5/16 x 3-3/4" Hex Bolts, Internal Tooth Lock Washers and Flat Washers. Note: center hole at 5" towards C1 Post *

STEP 1

Start by laying C2, C1 and C3 Posts flat on ground. Install 5/16" Spike T-Nuts in the double holes that are towards the bottom of posts. Then flip posts over so that the T-Nuts are towards the ground. Then place H3 Floor Rail, five-hole board, on C2 and C1 Post. Note: The single hole in the H3 Rail is towards C2, and then attach using 5/16x3-3/4"HEX BOLTS, Internal Tooth Lock Washers and Flat Washers.

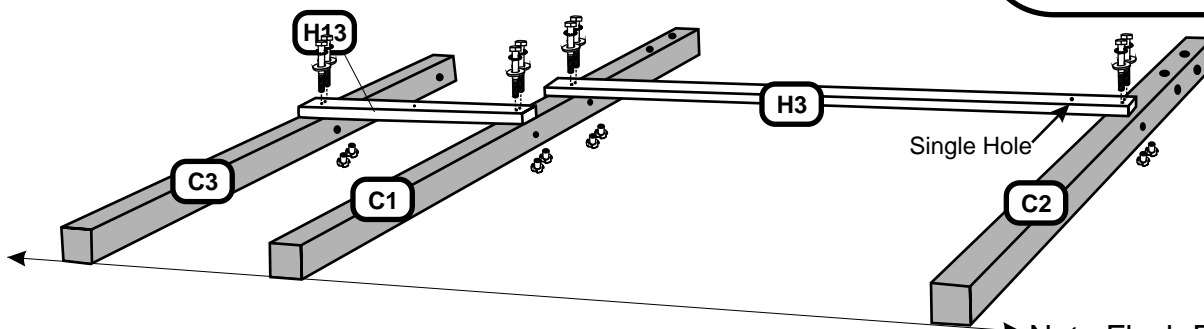
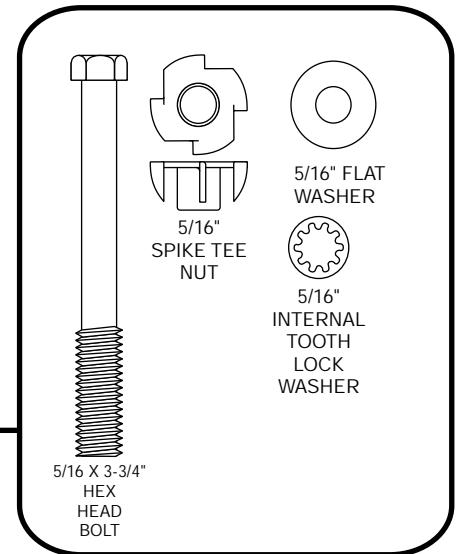

Note Flush Bottom of Posts

STEP 3

Lay opposite Posts C2, C1 and C3 as before in Step 1 and Step 2, and place 5/16" Spike T-Nuts in posts and attach H3, again noting single hole toward C2 Post, using 5/16 x 3-3/4" Hex Bolt, Internal Tooth Lock Washers and Flat Washers

STEP 4

Attach H13 Floor Rail, five-hole, to C1 and C3 Posts using 5/16 x 3-3/4" Hex Bolts, Internal Tooth Lock Washers, Flat Washers and Spike T Nut.

H6 Floor Rail * 6 Holes * 1 Req
 1 x 3-1/2 x 47 [2.54 x 8.89 x 119.38]



H7 Floor Rail * 4 Holes * 2 Req
 1 x 3-1/2 x 47 [2.54 x 8.89 x 119.38]

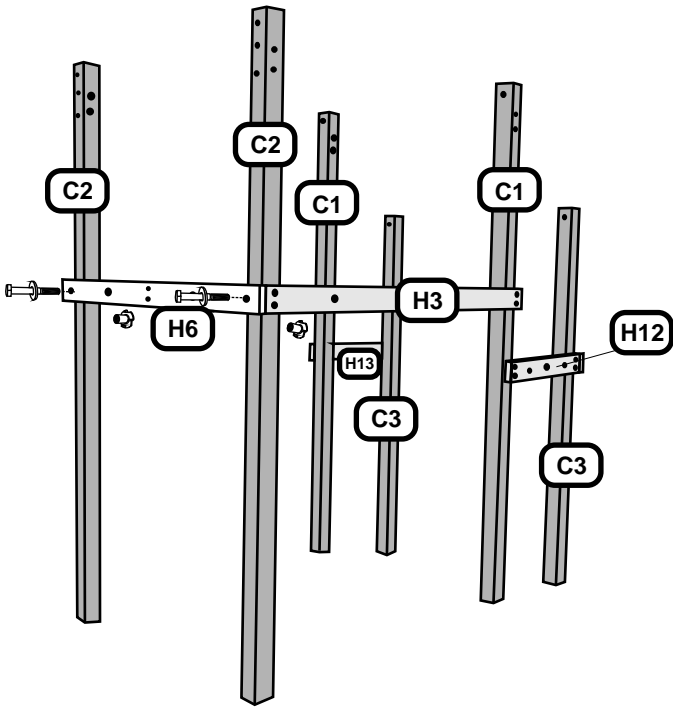

STEP 5

This step will take two people. Stand up front and back assemblies. Attach Left Floor Rail H6 to C2 Post using 5/16"x3-3/4" Hex Bolts, Internal Tooth Lock Washers, Flat Washers and Spike T Nut.

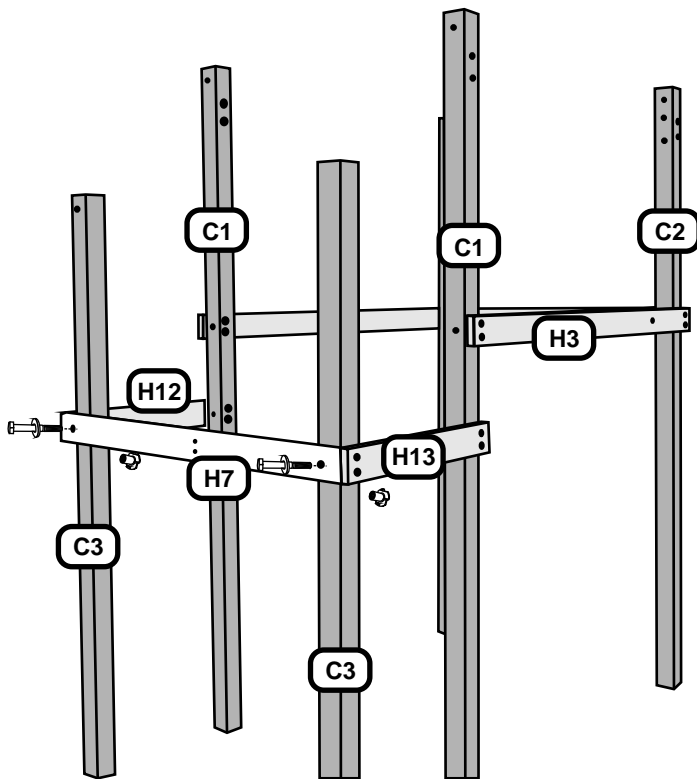
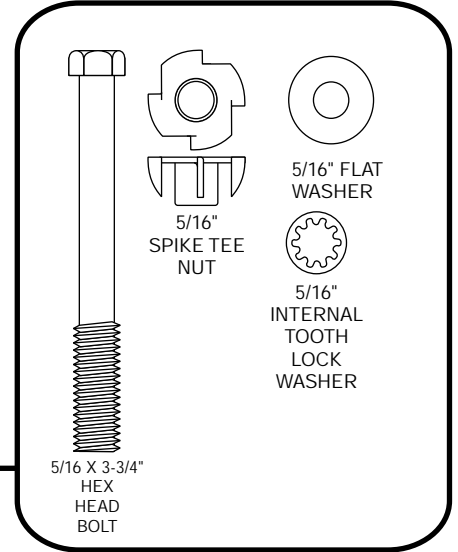

STEP 6

Attach Right Floor Rail H7 to C3 Post using 5/16 x 3-3/4" Hex Bolts, Internal Tooth Lock Washers, Flat Washers and Spike T Nut.

H7 Floor Rail * 4 Holes * 2 Req
 1 x 3-1/2 x 47 [2.54 x 8.89 x 119.38]



H8 Floor Rail * 4 Holes * 1 Req
 1 x 3-1/2 x 45 [2.54 x 8.89 x 114.30]

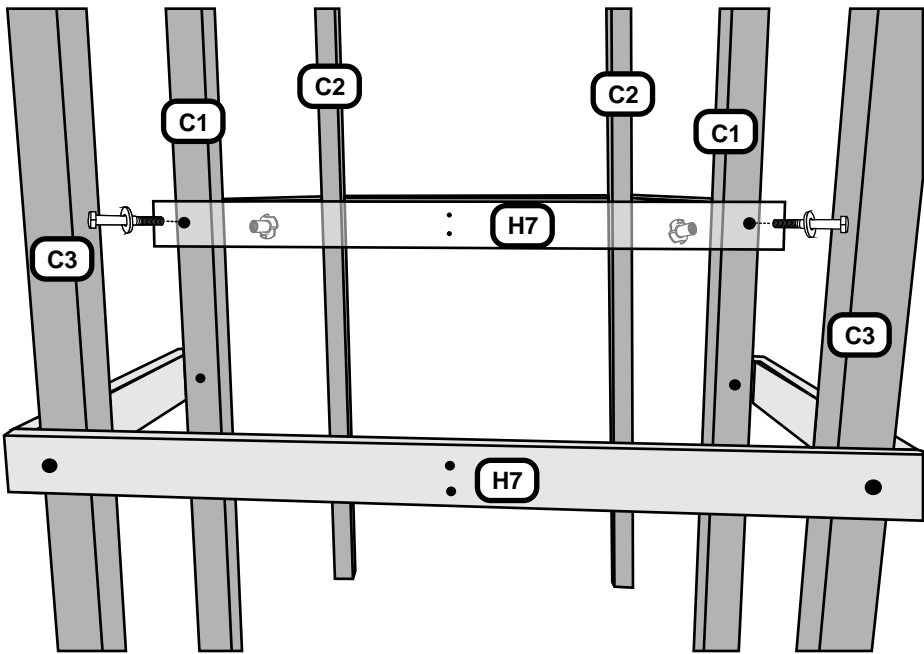

STEP 7

Attach another H7 Floor Rail to C1 Post using 5/16 x 3-3/4" Hex Bolts, Internal Tooth Lock Washers, Flat Washers and Spike T Nut.

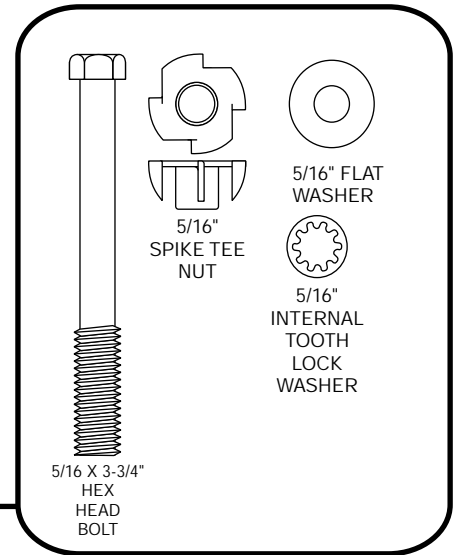

STEP 8

Attach H8 Floor Rail, four-hole, to C1 Post using 5/16 x 3-3/4" Hex Bolts, Internal Tooth Lock Washers, Flat Washers and Spike T Nut.

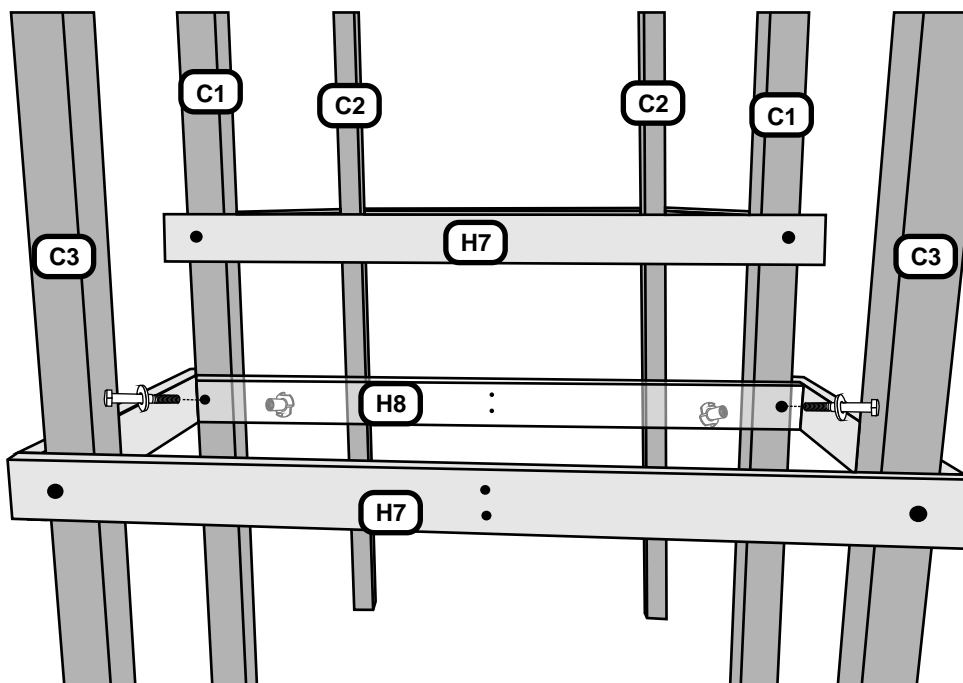

G1 Base Board * 6 Holes * 2 Req
 1 x 5-1/2 x 78-1/2 [2.54 x 13.97 x 199.39]



G5 Base Board * 6 Holes * 1 Req
 1 x 5-1/2 x 47 [2.54 x 13.97 x 119.38]

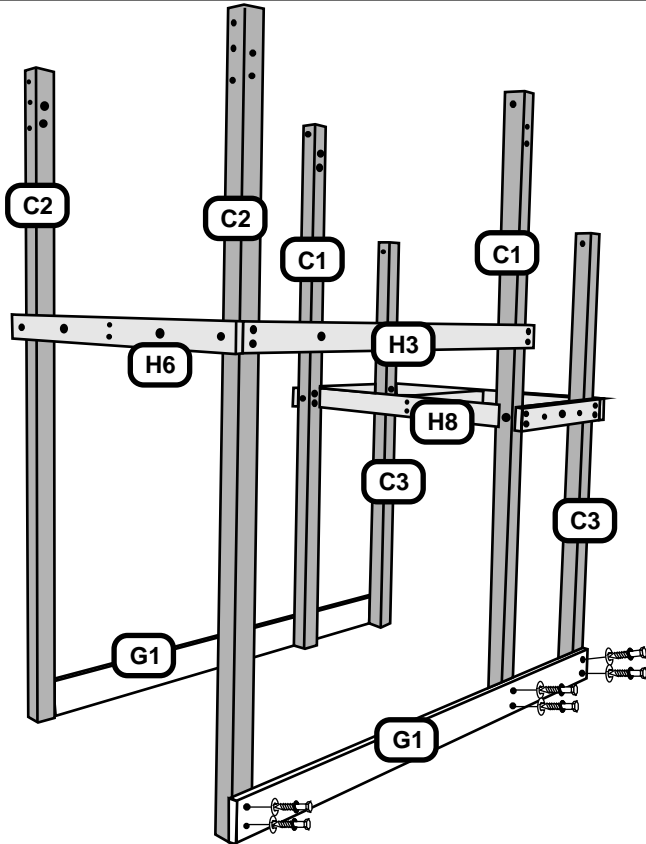
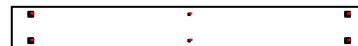

STEP 9

Attach G1 Front and Back Baseboards, placing flush with outside of C2 and C3 Posts, pilot drill with 3/16" bit using holes in G1 as guide and attach using 5/16x2-1/2" Lag Screws, Internal Tooth Lock Washers and Flat Washers. Center C1 post straight up and down and finish attaching G1 using 2 1/2" lag screws, lock washers and flat washers.

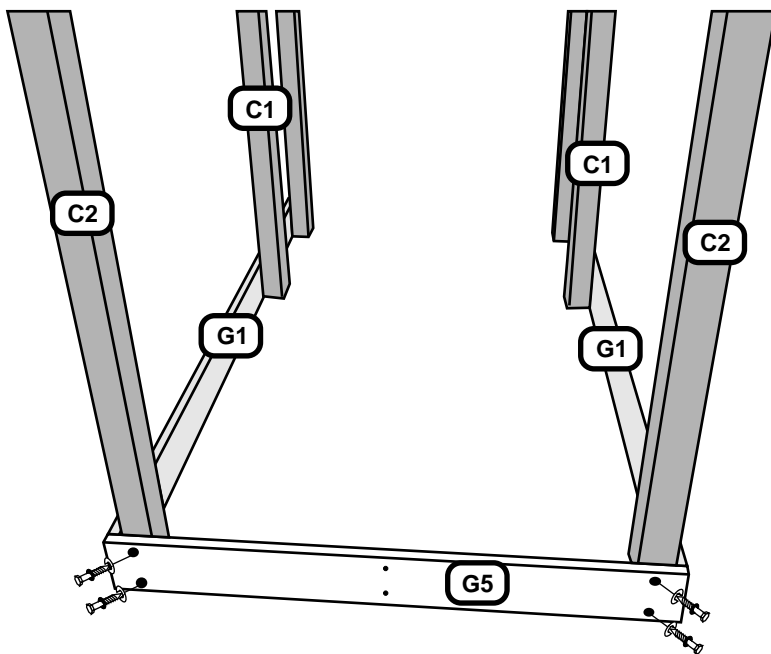
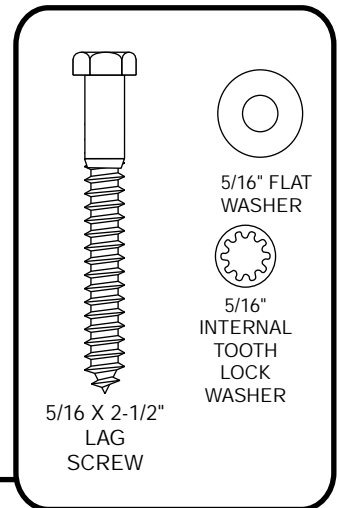

STEP 10

Attach G5 Left Baseboard to C2 Post, flushing with outside of G1 Baseboards, pilot drill with 3/16" bit using holes in G5 as guide and attach using 5/16x2-1/2" Lag Screws, Internal Tooth Lock Washers and Flat Washers.

G6 Base Board * 4 Holes * 1 Req
 1 x 5-1/2 x 47 [2.54 x 13.97 x 119.38]

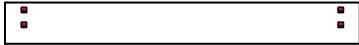

G7 Base Board * 6 Holes * 1 Req
 1 x 5-1/2 x 45 [2.54 x 13.97 x 114.30]

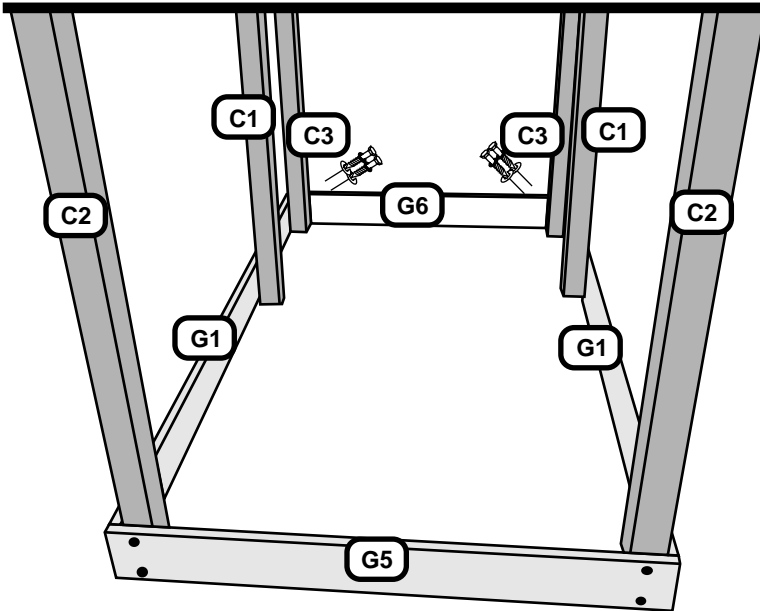

STEP 11

Attach G6 Right Baseboard on C3 Post, flushing with G1 Baseboard, pilot drill with 3/16" bit using holes in G6 as a guide. Attach using 2-1/2" Lag Screws, Internal Tooth Lock Washers and Flat Washers.

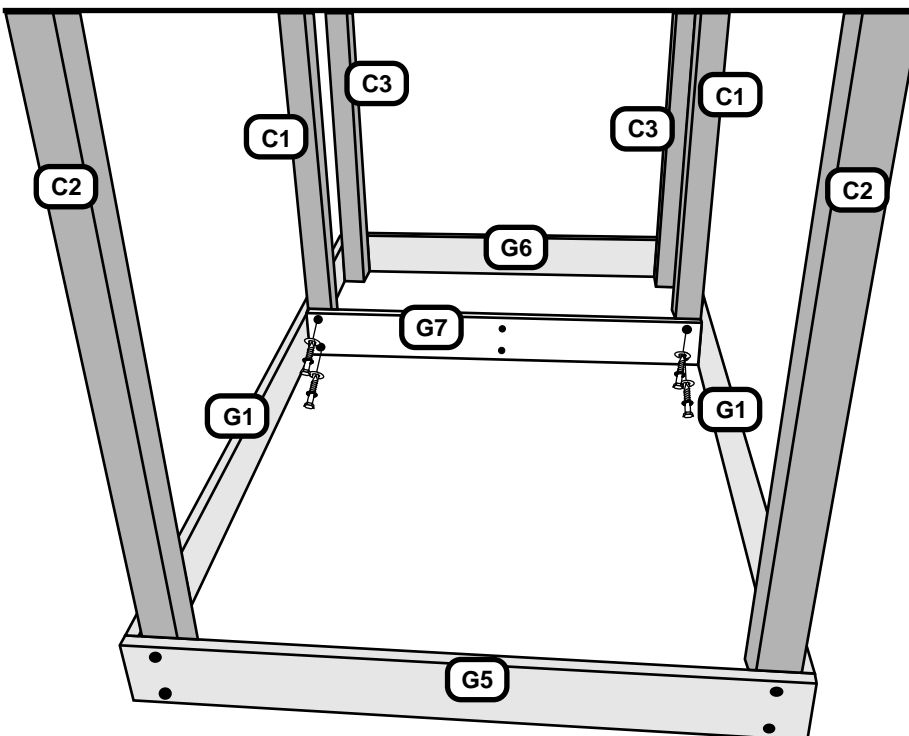
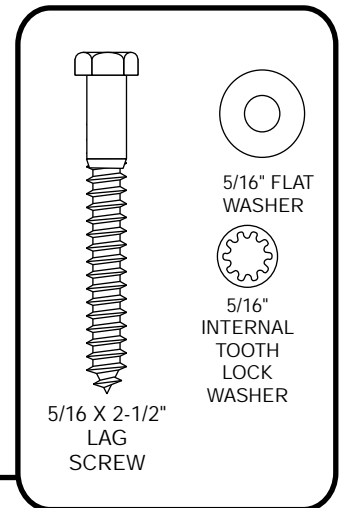

STEP 12

Attach G7 Center Baseboard, 6-hole, on Left side of C1 Post, pilot drill with 3/16" bit using holes in G7 as a guide. Attach using 2-1/2" Lag Screws, Internal Tooth Lock Washers and Flat Washers.

G3 Bottom Floor Joist * No Holes * 1 Req
1 x 5-1/2 x 53-1/2 [2.54 x 13.97 x 135.89]

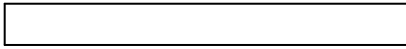

H4 Floor Joist * No Holes * 1 Req
1 x 3-1/2 x 57-1/2 [2.54 x 8.89 x 146.05]

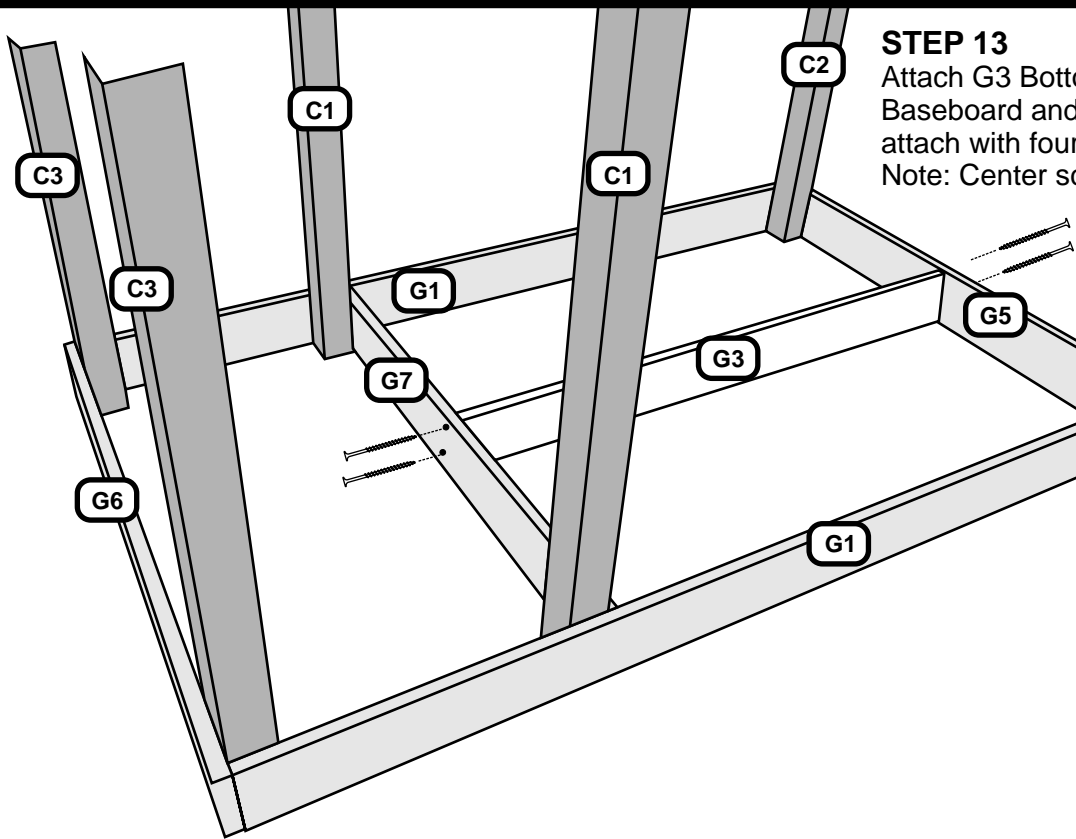
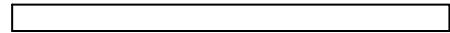

STEP 13

Attach G3 Bottom Floor Joist between G7 Baseboard and Left G5 Baseboard and attach with four 2-1/2" Wood Screws. Note: Center screws into G3.

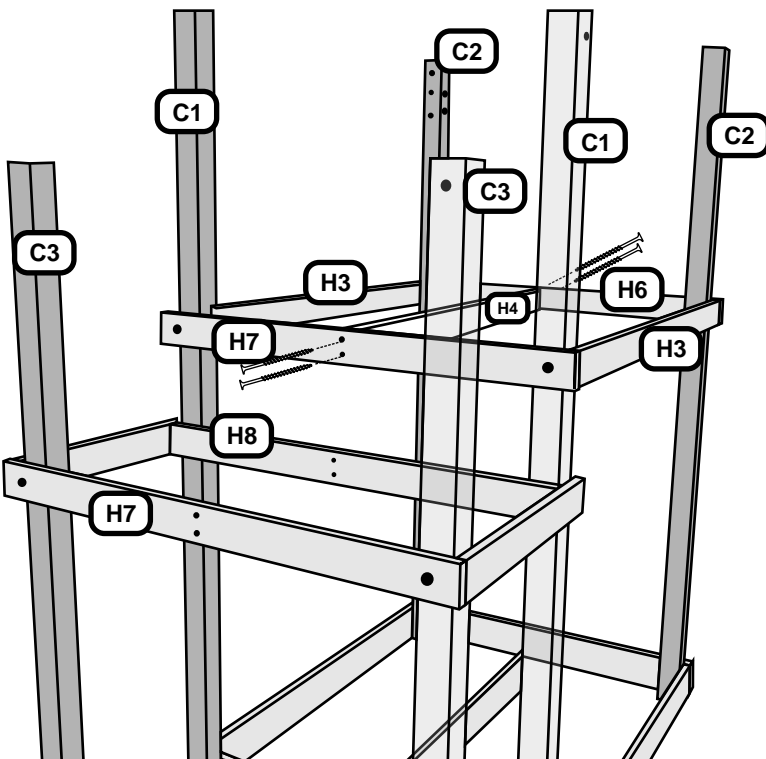
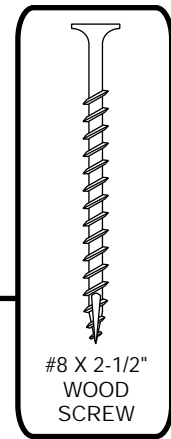

STEP 14

Attach H4 Top Floor Joist between H6 Left Floor Rail and H7 Right Floor Rail using four 2-1/2" Wood Screws. Note: Center screws into H7.

H14 Floor Joist * No Holes * 1 Req
 1 x 3-1/2 x 20 [2.54 x 8.89 x 50.80]

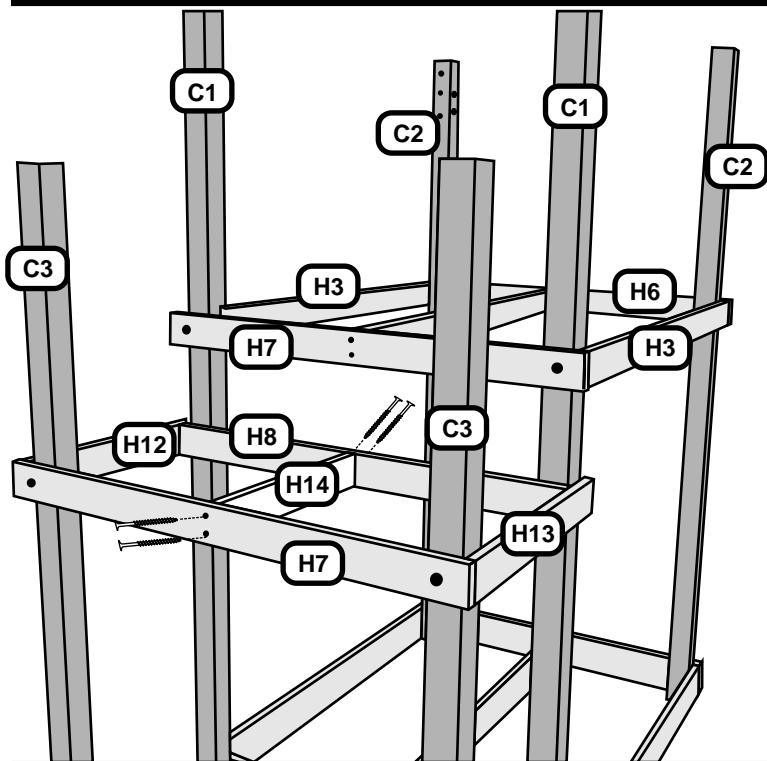
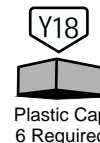
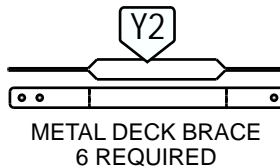
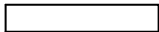

STEP 15

Attach H14 Lower Top Floor Joist to H7 Right Floor Rail and H8 Center Floor Rail using four 2-1/2" Wood Screws. Note: Center screws into H14.

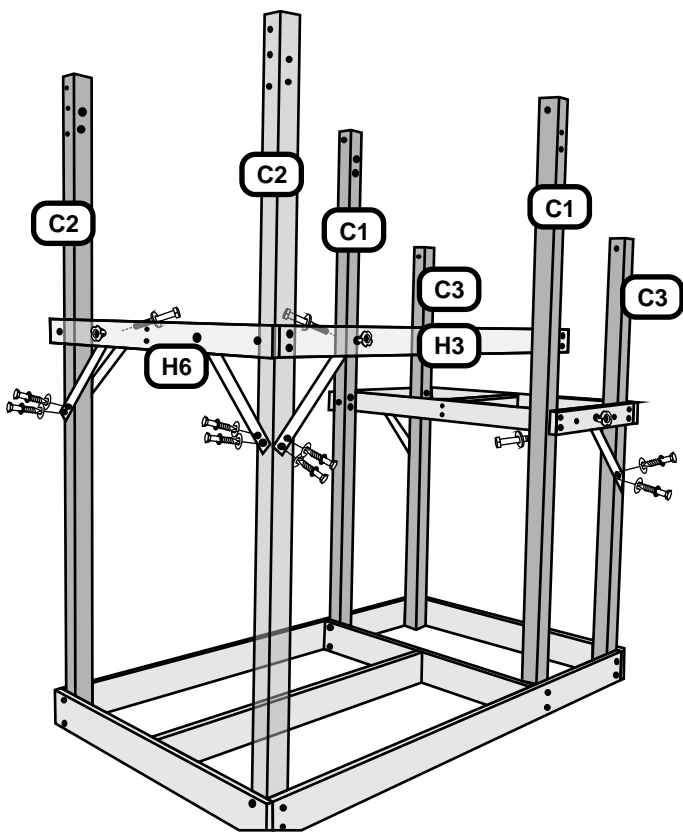
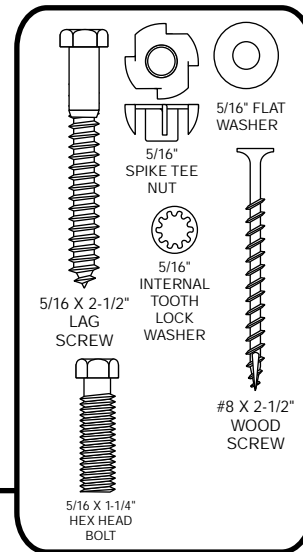

STEP 16

Attach 5/16" Spike T-Nuts on outside of Floor Rails on left front and back of Upper Floor Rails and front and back of Lower-Upper Floor Rails. Now attach Y2 Deck Braces using 5/16 x 1-1/4" Hex Bolts, Internal Tooth Lock Washers and Flat Washers. At this point, level Set at each corner and attach Y2 Deck Braces, to the Tower Posts, pilot drill using 3/16" bit and attach using 2-1/2" Lag Screws, Internal Tooth Lock Washers and Flat Washers.

STEP 17

At this point, place the Y18 Plastic Post Caps on all six of the Tower Posts.

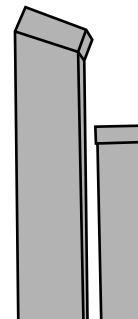
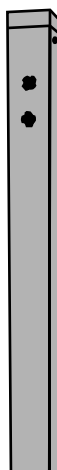

L1 Floor Board * 4 Holes * 4 Req
 11/16 x 4-1/2 x 39 [1.74 x 11.43 x 99.06]

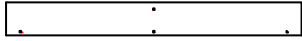

M3 Floor Board * 5 Holes * 34 Req
 11/16 x 3-3/8 x 47 [1.74 x 8.57 x 119.38]



N1 Floor Board * 5 Holes * 1 Req
 11/16 x 2-1/2 x 47 [1.74 x 6.35 x 119.38]

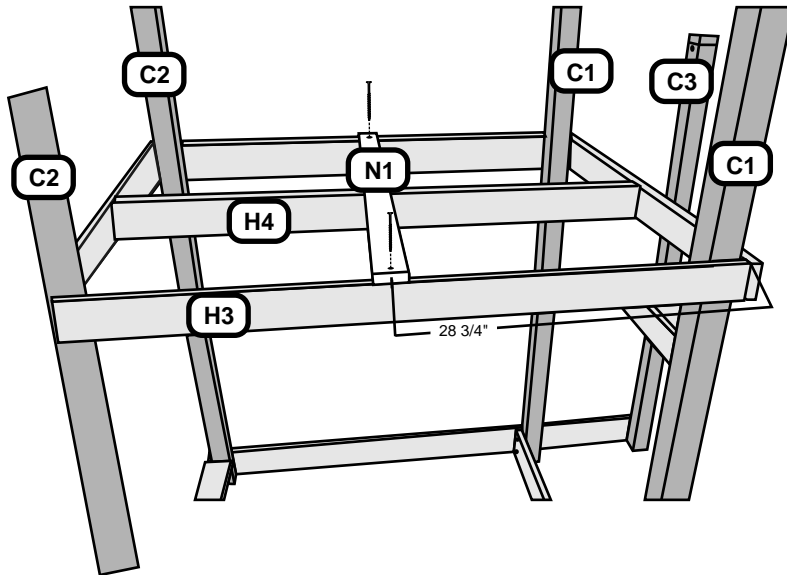
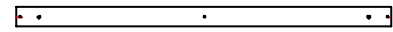

STEP 18

Now at Front Floor Rail and Back Floor Rail measure to center of Rail approximately 28-3/4" and mark Rail. Now attach N1, five-hole Floor Board, in center of floor using marks to locate, and Attach using 2" Wood Screws.

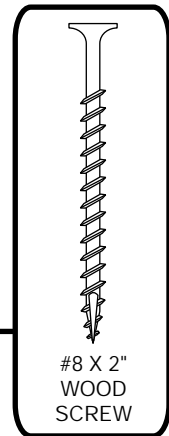

#8 X 2"
WOOD
SCREW

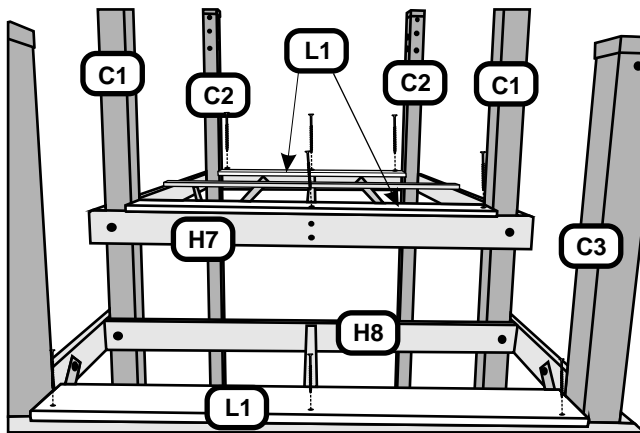

STEP 19

Attach L1, four-hole Floor Boards, between Tower Posts flushing to outside of Left and Right Floor Rail on Top Floor and between C3 Posts on Lower Floor flush with the Right Floor Rail. Attach using 2" Wood Screws.

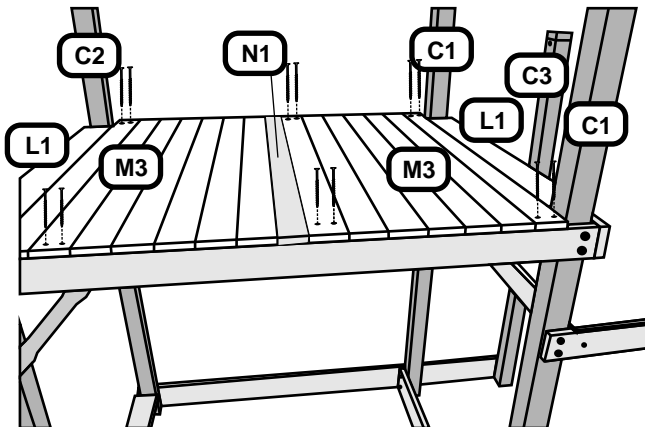

STEP 20

On Upper Floor place M3, five-hole Floor Boards, seven on each side of N1 Center Floor Board, and space evenly. Then attach using 2" Wood Screws.

G2 Arched Wall Rail * 4 Holes * 2 Req
 1 x 5-1/2 x 57-1/2 [2.54 x 13.97 x 146.05]



METAL STAKES

L1 Floor Board * 4 Holes * 4 Req
 11/16 x 4-1/2 x 39 [1.74 x 11.43 x 99.06]

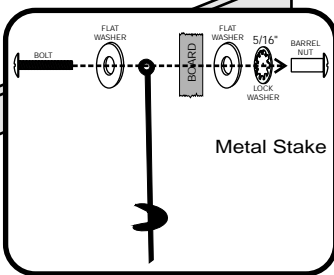
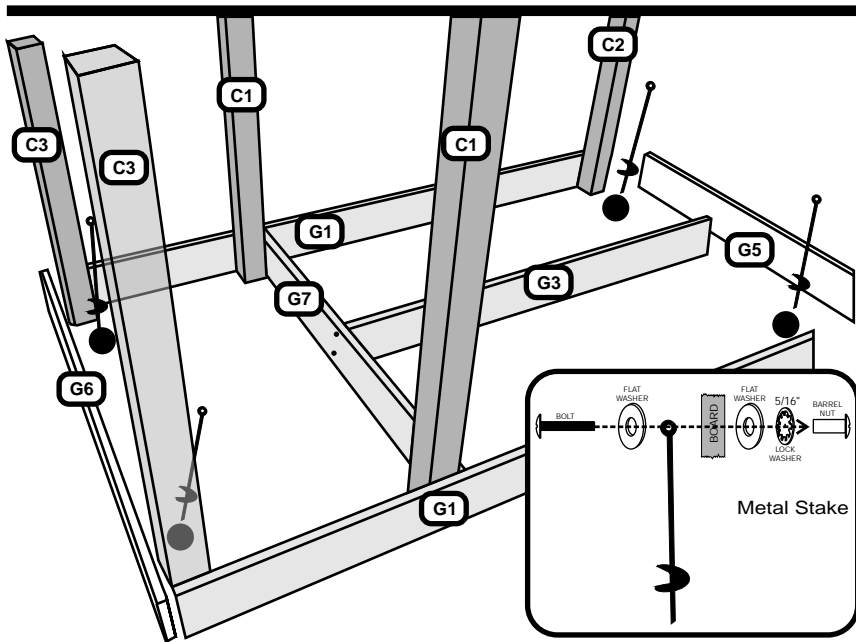
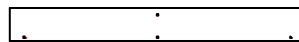

STEP 21

Now is the time to position unit in permanent spot. Secure the playset to the ground by using the stakes in the locations shown by the black circles.

Metal stake installation: Measure in 8" from inside post and mark ground for stake location. Now remove G5 and G6 base board to allow room to twist stake into ground. You will need a long screwdriver for leverage. In some cases you may need to dig a hole to install stake and cement. Now reattach the G5 and G6 baseboards to the unit

Use hole in stake as guide to drill 3/8" pilot hole thru base board use 1" phillips truss head bolt, 5/16" flat washer thru stake into baseboard 5/16" flat washer, 5/16" lock washer on barrel nut attach to base board.

Attach another L1, four-hole Floor Board, on bottom deck area between C2 Post flush to outside of Left Baseboard using 2" Wood Screws.

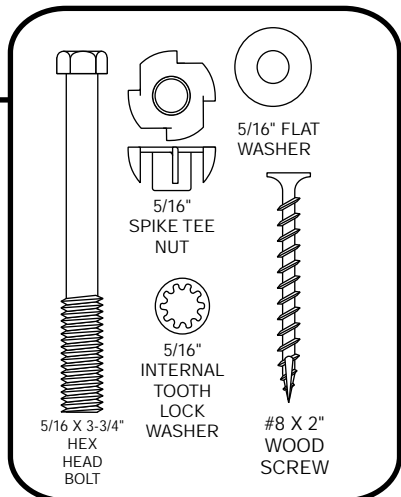
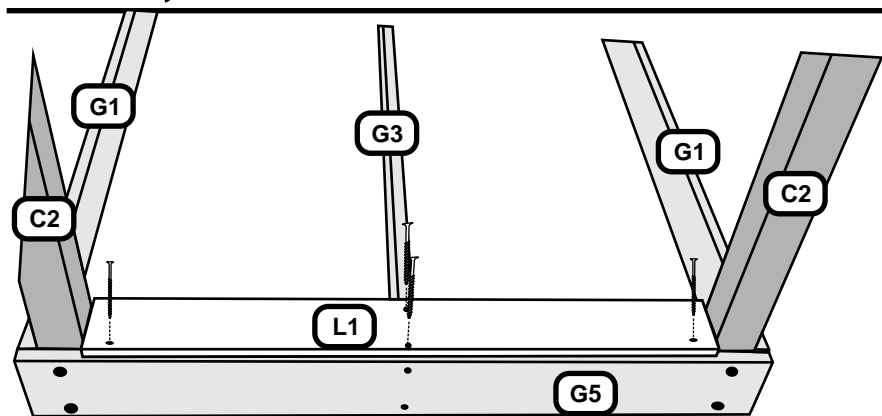

STEP 22

Drive 5/16" Spike T-Nuts into inside of C2 and C1 Posts. Then attach G2 Sculptured Rails to front and back of C2 and C1 Posts using 5/16 x 3-3/4" Hex Bolts, Internal Tooth Lock Washers and Flat Washers.

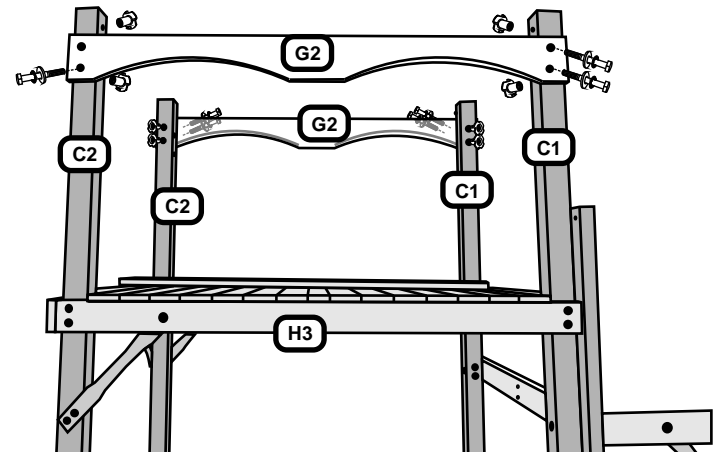

G4 Club House Wall Rail * 8 Holes * 1 Req
 1 x 5-1/2 x 47 [2.54 x 13.97 x 119.38]

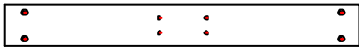

M3 Floor Board * 5 Holes * 34 Req
 11/16 x 3-3/8 x 47 [1.74 x 8.57 x 119.38]

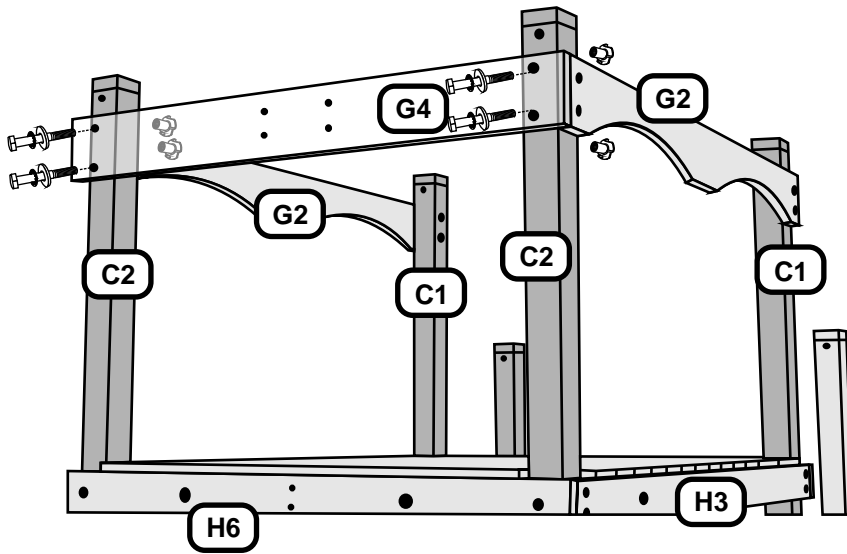

STEP 23

Attach G4, eight-hole, Clubhouse Wall Rail to C2 Post using 5/16 x 3-3/4" Hex Bolts, Internal Tooth Lock Washers, Flat Washers and Spike T Nuts.

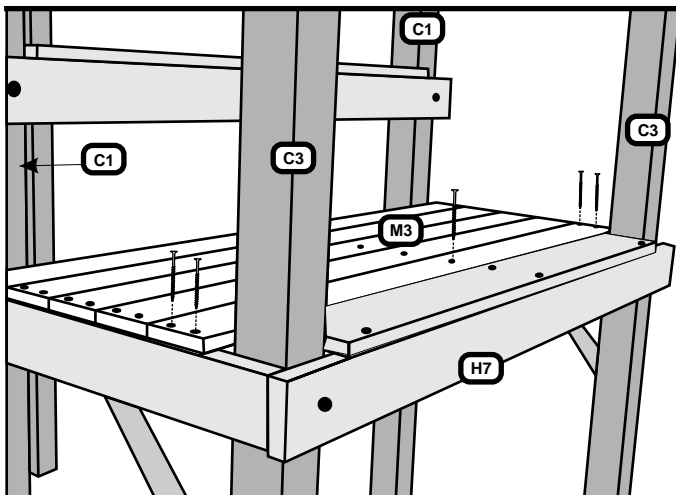
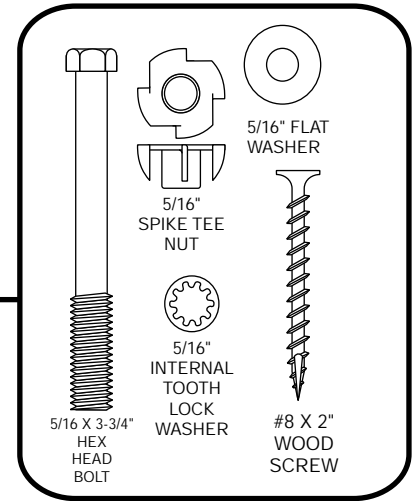

STEP 24

Now install five M3 Floor Boards on Top-Lower Floor spacing evenly using 2" Wood Screws.

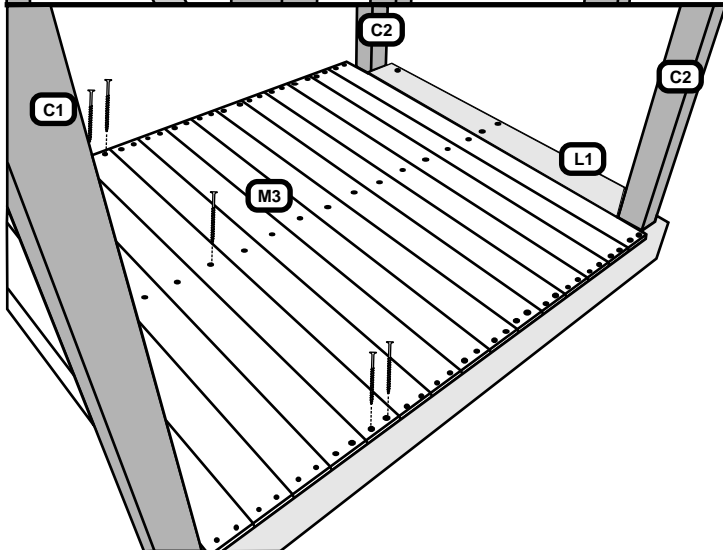

STEP 25

At this point, install Lower Deck Floor Boards, M3, using 2" Wood Screws spacing fifteen M3 Floor Boards evenly.

M5 Club House Rail * 4 Holes * 2 Req
1 1/16 x 3-3/8 x 45 [1.74 x 8.57 x 114.30]

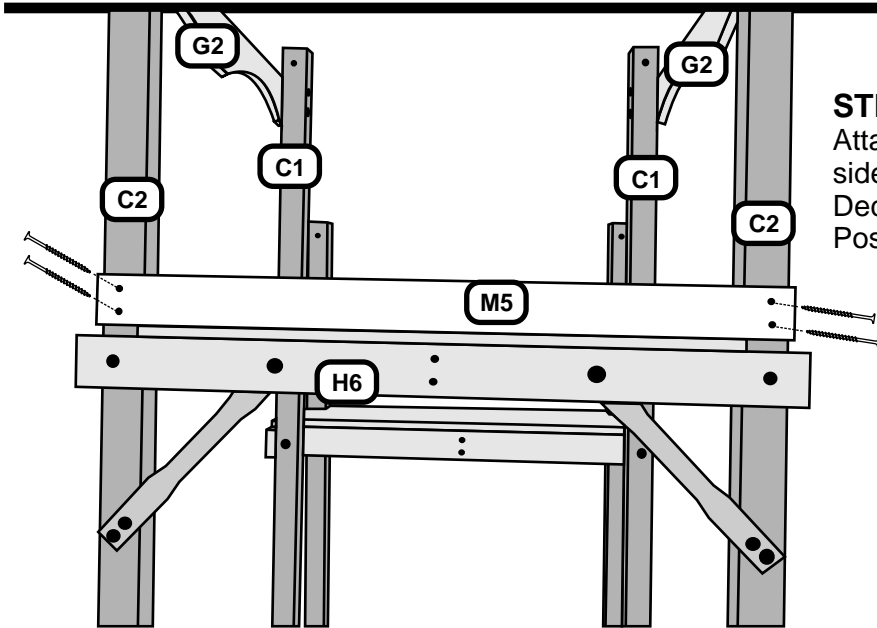
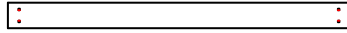

STEP 26

Attach M5, four-hole, Clubhouse Rail at left side of Tower C2 Post. Place on top of L1 Deck Board and flush with outside of C2 Post. Attach using 2" Wood Screws.

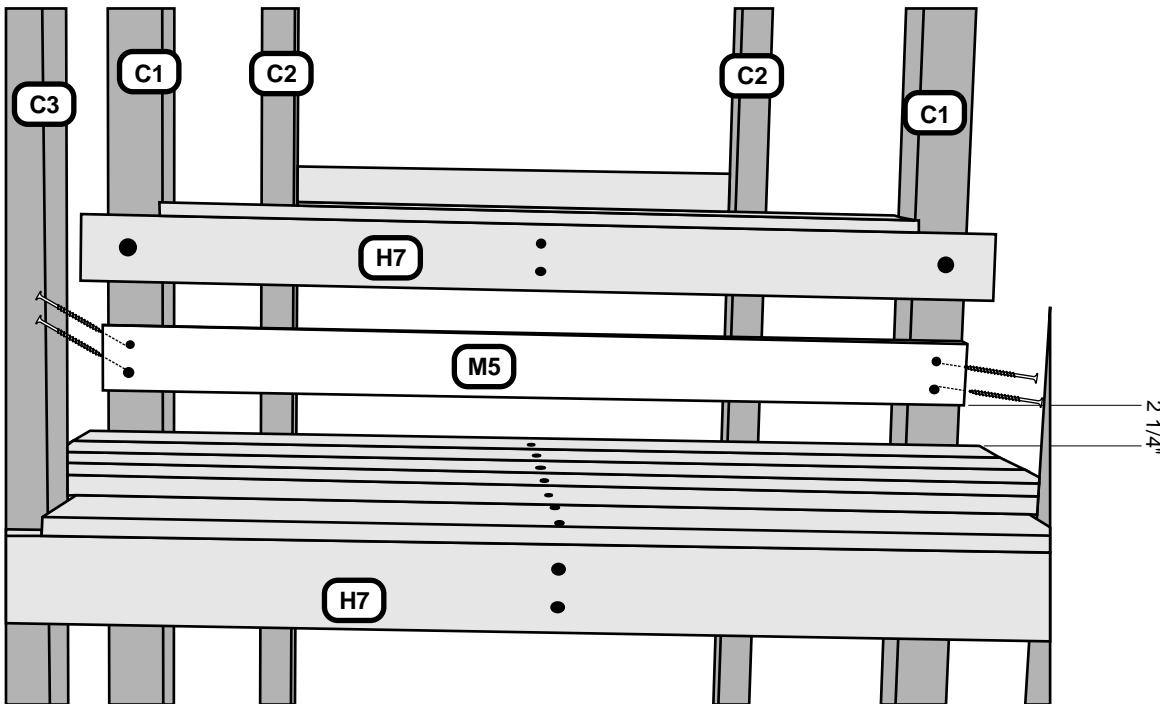
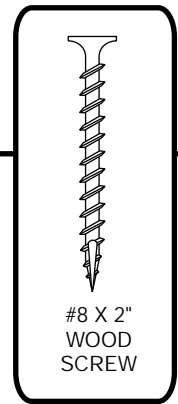

STEP 27

Attach M5, four-hole, Clubhouse Rail at C1 Post above Lower and Top Deck; measuring 2-1/4" up from top of M3 Floor Board mark C1 Post. Attach using 2" Wood Screws.

G8 Club House Wall Support * 5 Holes * 2 Req
 1 x 5-1/2 x 29 [2.54 x 13.97 x 73.66]



Y9

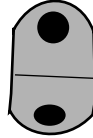

M8 Club House Rail * 3 Holes * 4 Req
 11/16 x 3-3/8 x 28-3/4 [1.74 x 8.57 x 73.03]

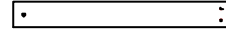

STEP 28

Attach a Y9 L-brace to G8 center upright placing 1/4"x3/4" phillips truss head bolt, lock washer and flat washer in countersunk hole of G8. NOTE: long end of Y9 to G8. Then use phillips barrel nut to finish fastening to G8. Now Attach two M8s to G8 using 1/4 x 1-1/4" Truss Head Bolts, 5/16" Internal Tooth Lock Washers, Flat Washers and Barrel Nuts to G8 Board.

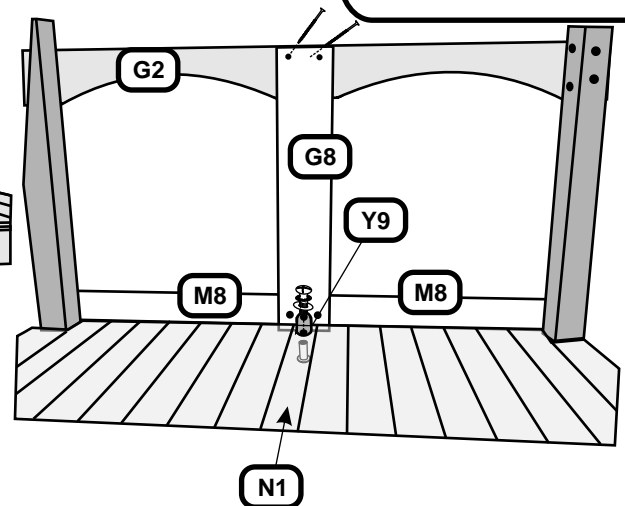
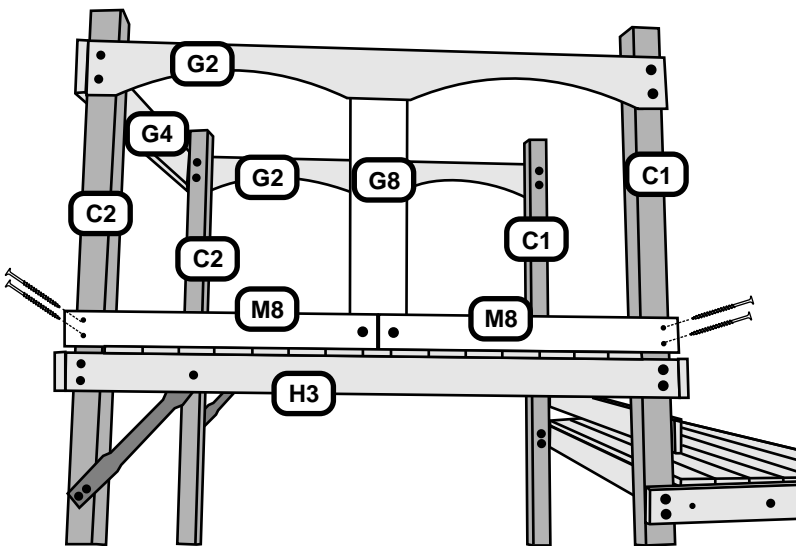
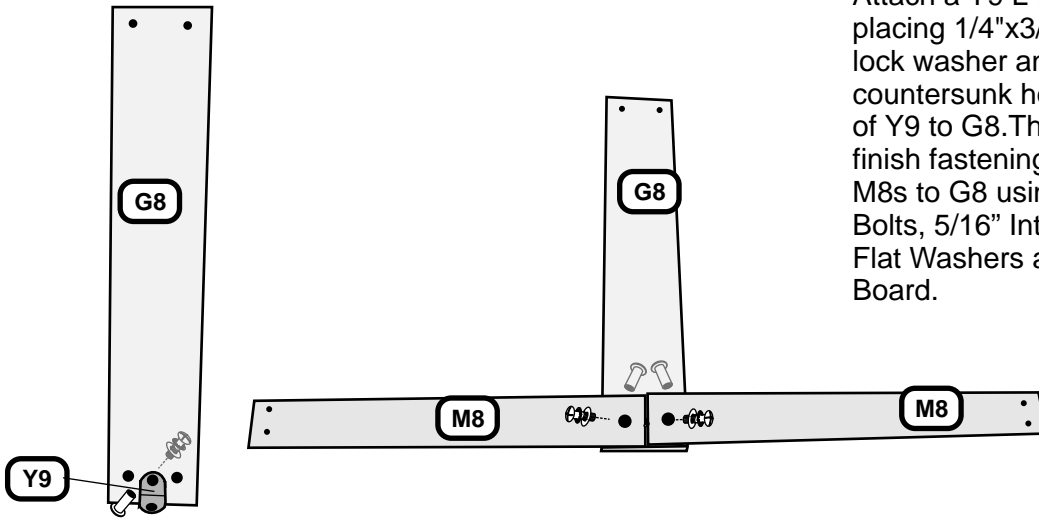

STEP 29

Now on front of tower, place G8 and M8 Assembly on top of Floor Rails and attach using 3/4" Phillips Truss Head Bolt through Y9 using Lock Washers and Flat Washers with a Barrel Nut on bottom side of N1 Center Floor Board. At this point, keep G8 as plumb up and down as possible and attach to G2 Sculptured Top Rail using 1-1/2" Wood Screws. Now in the pre-drilled holes on M8 Wall Rails attach to C-Posts with 2-1/2" Wood Screws. Repeat G8 and M8 process on back of tower.

H1 Roof Support * 4 Holes * 2 Req
 1 x 3-1/2 x 59-1/2 [2.54 x 8.89 x 151.13]

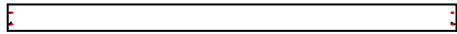

H5 Roof Support * 4 Holes * 2 Req
 1 x 3-1/2 x 57 [2.54 x 8.89 x 144.78]

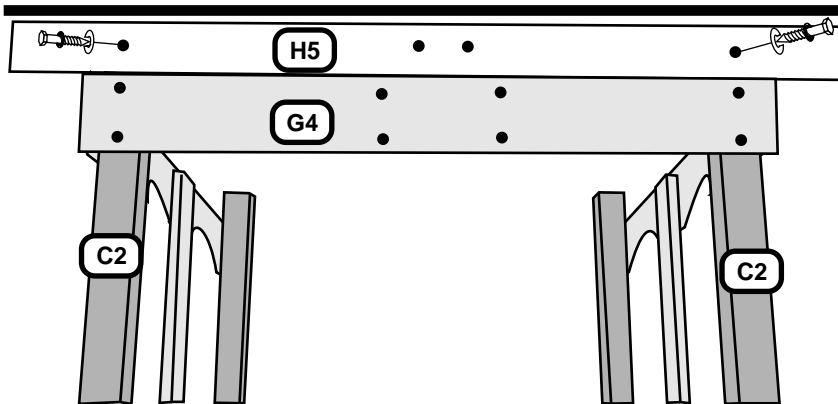

STEP 30

Attach H5 Roof Support, four-hole, centering countersink holes in H5 to C2 Posts on left side of Tower. H5 will sit on top of G4 Clubhouse Rail, pilot drill with 3/16" bit using holes in H5 as guides, and fasten with 2-1/2" Lag Screws, Internal Tooth Lock Washers and Flat Washers.

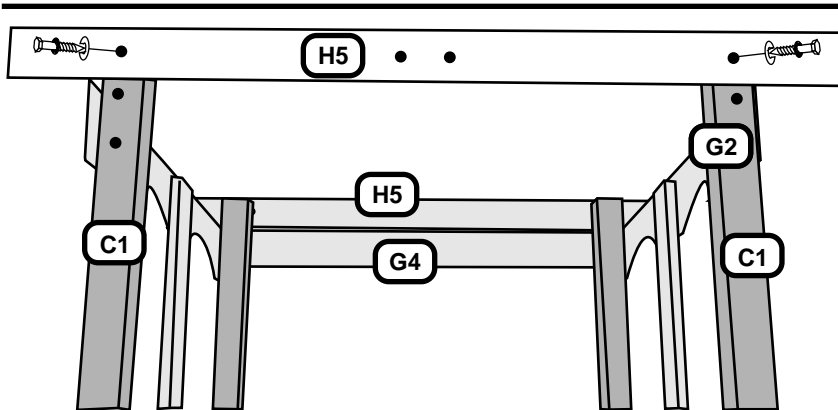
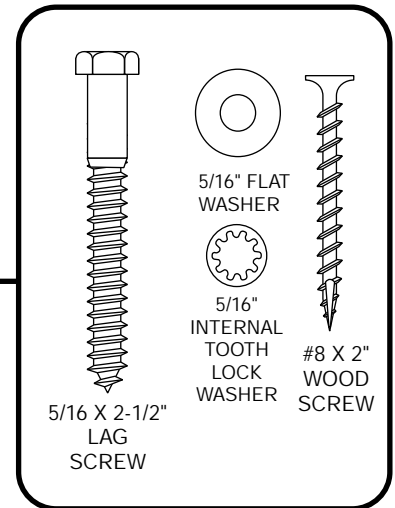

STEP 31

Now attach opposite H5 to C1 Post, again centering countersinks in Post. The bottom of H5 will be flush with Top of Front and Back G2 Sculptured Rails, again pilot drill with 3/16" bit and fasten with 2-1/2" Lag Screws, Internal Tooth Lock Washers and Flat Washers.

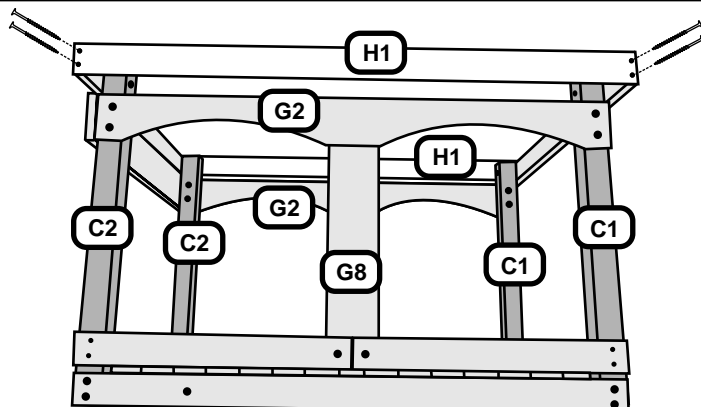

STEP 32

Attach H1 Roof Supports flush with outside of H5s, Front and Back of Tower Structure and fasten with 2" Wood Screws.

H2 Tent Support * 4 Holes * 1 Req
 1 x 3-1/2 x 59-1/2 [2.54 x 8.89 x 151.13]

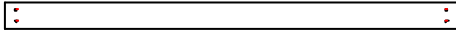

M2 Roof Spacer * 3 Holes * 2 Req
 11/16 x 3-3/8 x 57-1/2 [1.74 x 8.57 x 146.05]



H10 Upright * 2 Holes * 2 Req
 1 x 3-1/2 x 29-1/2 [2.54 x 8.89 x 74.93]

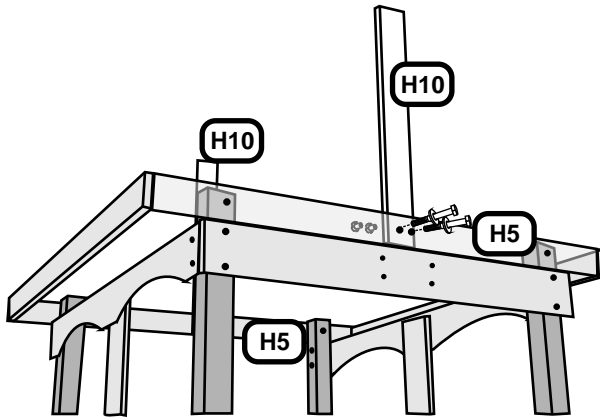
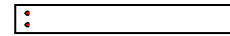

STEP 33

Attach H10 Tent Uprights to H5 Roof Supports using 5/16 x 1-3/4" Hex Bolts, Internal Tooth Lock Washers, Flat Washers and Spike T Nuts. Level H10's.

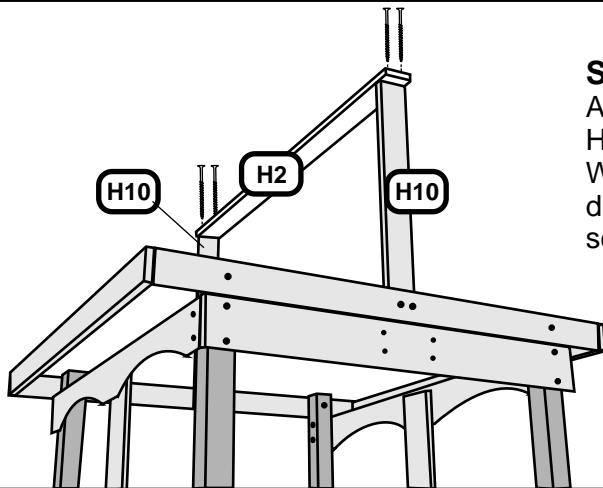
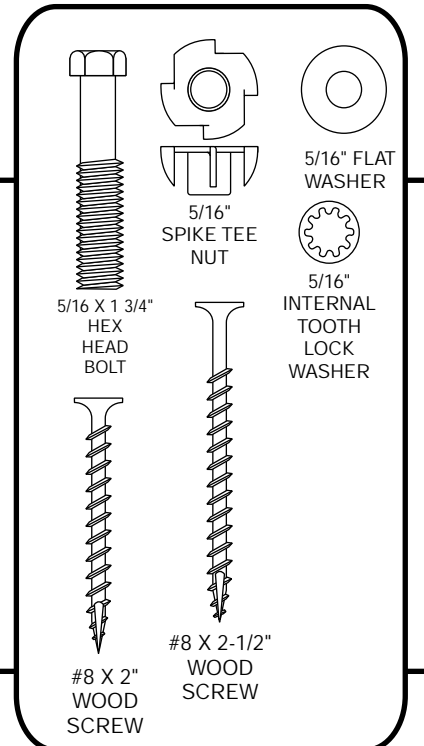

STEP 34

Attach H2 Tent Support to H10 Uprights using 2-1/2" Wood Screws through pre-drilled holes in H2. Center screws into H10's.

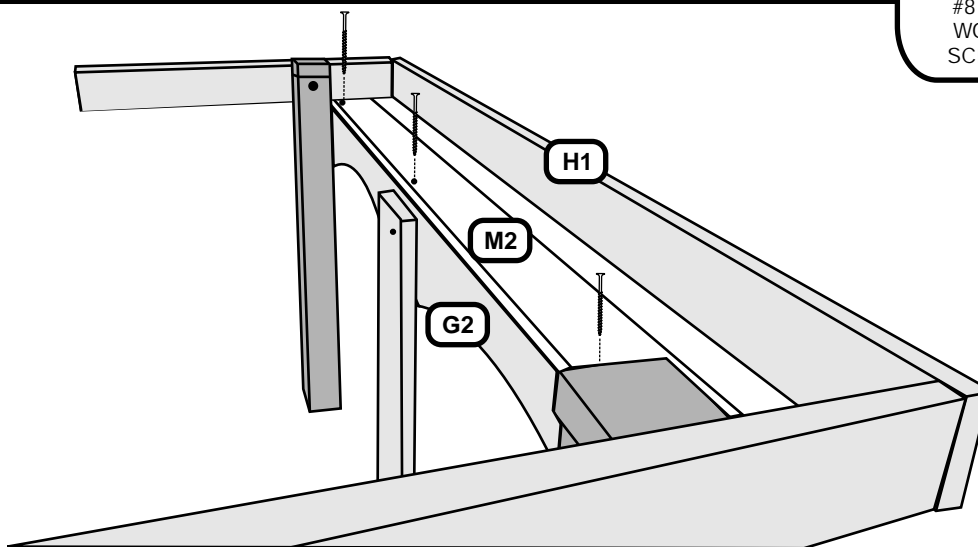

STEP 35

Attach M2 Roof Spacers at front and back to G2 Sculptured Rails flushing with inside of G2 Sculptured Rails. Use 2" Wood Screws through pre-drilled holes in M2s to fasten.

L2 Club House Wall Board * 4 Holes * 1 Req
11/16 x 4-1/2 x 29 [1.74 x 11.43 x 73.66]

M6 Club House Wall Board * 4 Holes * 28 Req
11/16 x 3-3/8 x 29 [1.74 x 8.57 x 73.66]

N3 Club House Wall Board * 2 Holes * 1 Req
11/16 x 2-1/2 x 16 [1.74 x 6.35 x 40.64]

M10 Club House Wall Board * 4 Holes * 6 Req
11/16 x 3-3/8 x 16 [1.74 x 8.57 x 40.64]

M7 Window Trim * 4 Holes * 1 Req
11/16 x 3-3/8 x 28-3/4 [1.74 x 8.57 x 73.03]

M12 Window Trim * 2 Holes * 2 Req
11/16 x 3-3/8 x 6-3/4 [1.74 x 8.57 x 17.15]

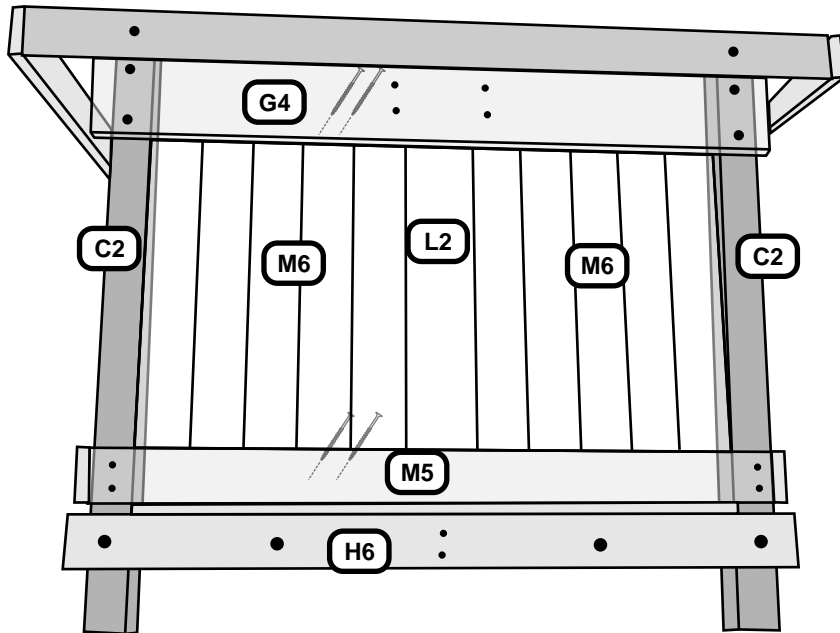

STEP 36

On left side of Tower, between C2 Posts, attach ten M6 Wall Boards and one L2 Wall Board. L2 will be in center with five M6s on each side. Space evenly apart and fasten with 1-1/2" Wood Screws at Top Rail and 1-1/4" Wood Screws at Bottom Rail.

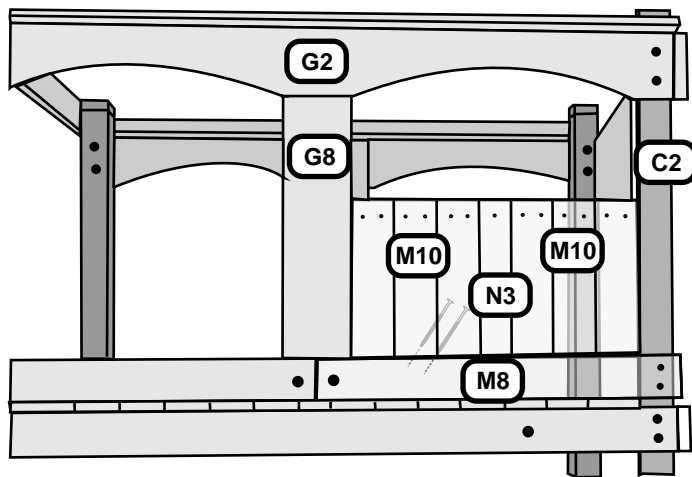
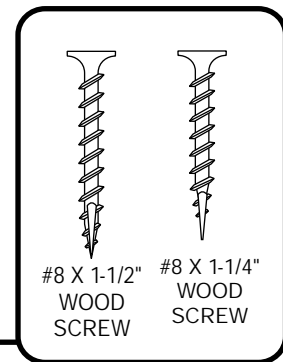

STEP 37

Attach six M10 Wall Boards and one N3 Wall Board to back left corner of clubhouse. Starting at C2 Posts, place three M10s; then place the one N3; and then place the last three M10s. Space evenly and fasten to Bottom Rail using 1-1/4" Wood Screws.

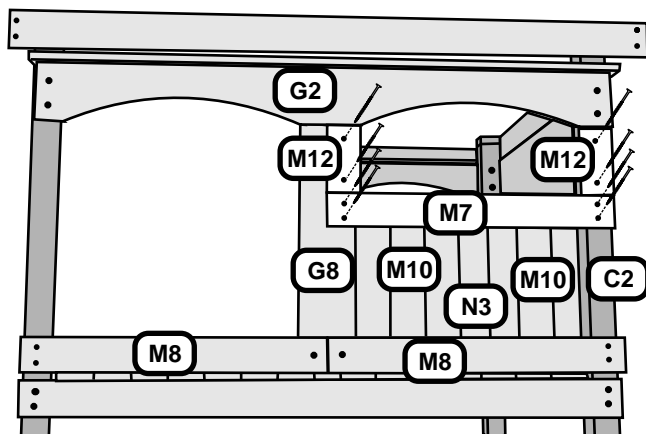

STEP 38

Attach M12 Window Trim to C2 Post pushed tight against G2 Sculptured Rail and flush with outside of Post using 1-1/2" Wood Screws. Then attach M7 Window Trim flush with outside edge of both M12 and C2 post. Fasten to C2 with 1-1/2" Wood Screws. Now attach M12 Window Trim butting ends tight at Top of G2 and flush with end of M7 Window Trim and fasten with 1-1/2" Wood Screws; finish by fastening top of Wall Boards N3 and M10s to M7, using 1-1/4" Wood Screws.

M6 Club House Wall Board * 4 Holes * 28 Req
 11/16 x 3-3/8 x 29 [1.74 x 8.57 x 73.66]

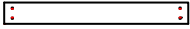

H9 Wall Rail * 2 Holes * 2 Req
 1 x 3-1/2 x 45 [2.54 x 8.89 x 114.30]

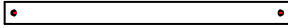

M9 Wall Board * 4 Holes * 23 Req
 11/16 x 3-3/8 x 23 [1.74 x 8.57 x 58.42]

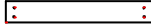

N2 Club House Wall Board * 2 Holes * 3 Req
 11/16 x 2-1/2 x 29 [1.74 x 6.35 x 73.66]

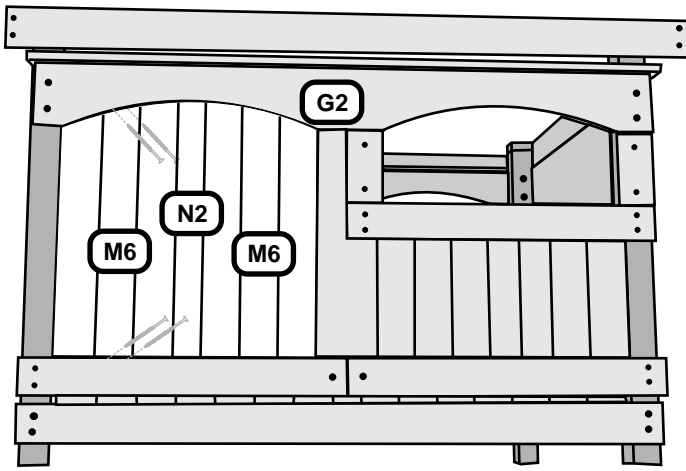
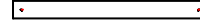

STEP 39

Attach six M6 Wall Boards and one N2 on back left placing three M6s, then one N2 and the remaining three M6s then Space evenly and Fasten using 1-1/4" Wood Screws in Bottom Rail and 1-1/2" Wood Screws in Top Rail. Now repeat on front left and front right of Tower Assembly.

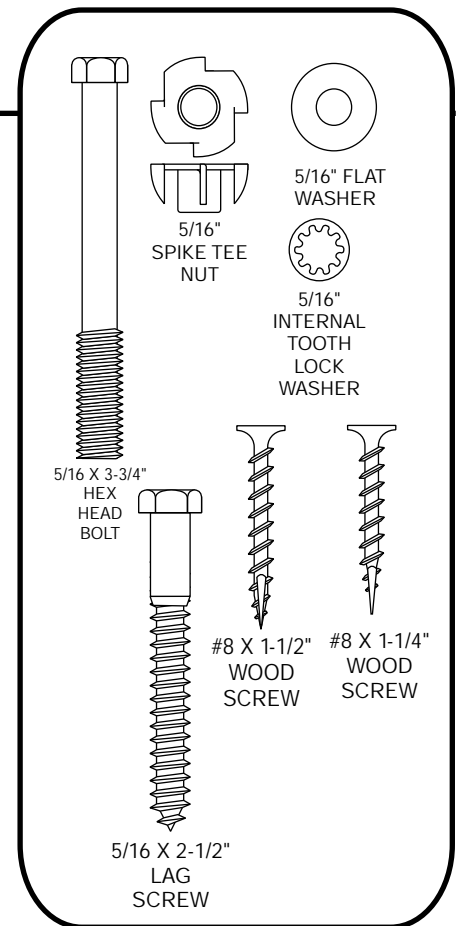
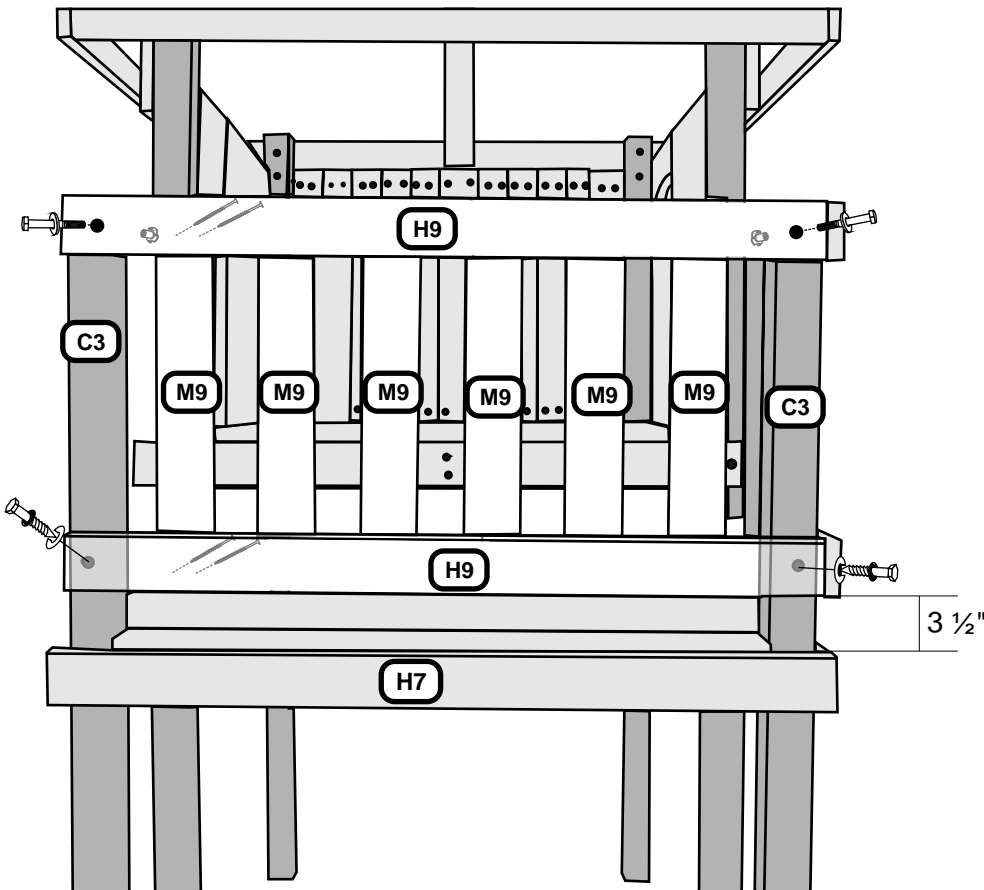

STEP 40

Install 5/16" Spike T-Nuts inside C3 Posts and attach H9 using 5/16 x 3-3/4" Hex Bolts, Internal Tooth Lock Washers and Flat Washers. Measure up 3-1/2" from top of H7 Floor Rail and mark C3 Post. Now attach H9 with bottom of H9 Wall Rail at marks on Post, pilot drill using 3/16" bit and attach using 2-1/2" Lag Screws, Internal Tooth Lock Washers and Flat Washers. Make sure that H9 is flush with outside of C3. Now attach six M9 Wall Boards to H9 Wall Rails on right side of Tower spacing approximately 2-3/4" apart using 1-1/2" Wood Screws.

H11 Wall Rail * 4 Holes * 2 Req
1 x 3-1/2 x 25 [2.54 x 8.89 x 63.50]

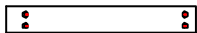

M1 Wall Rail * 4 Holes * 2 Req
1 1/16 x 3-3/8 x 57-1/2 [1.74 x 8.57 x 146.05]

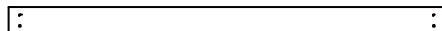

M9 Wall Board * 4 Holes * 23 Req
1 1/16 x 3-3/8 x 23 [1.74 x 8.57 x 58.42]

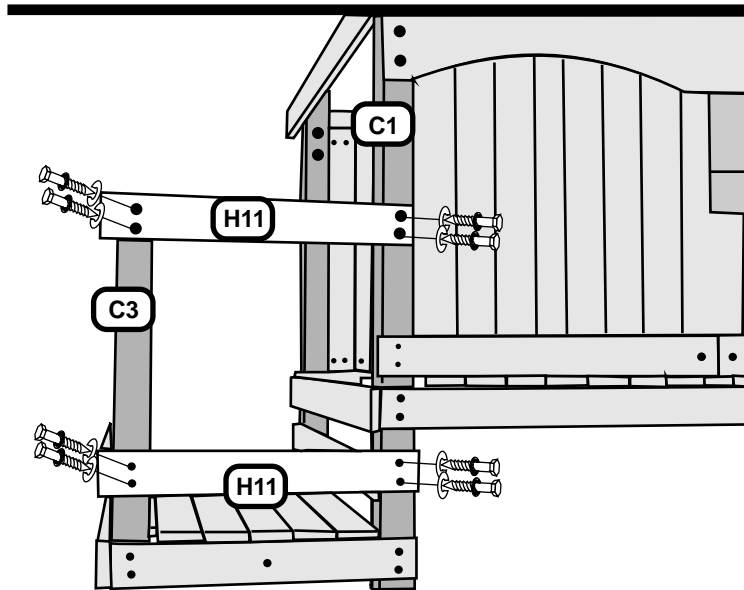
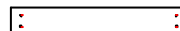

Step 41

Attach H11 Wall Rails, noting countersunk holes drilled at 2-1/2" from edge go towards C3 Posts. Flush H11 to outside of H9 Front Wall Rail at top and bottom pilot drill with 3/16" bit using holes in H11 as guides and fasten using 2-1/2" Lag Screws, Internal Tooth Lock Washers and Flat Washers. Now level H11's and fasten to C1 Posts using 2-1/2" Lag Screws, Internal Tooth Lock Washers and Flat Washers.

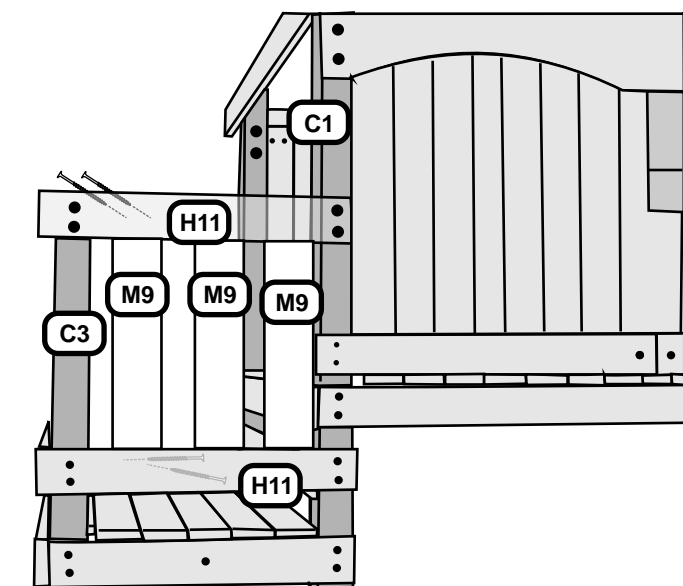
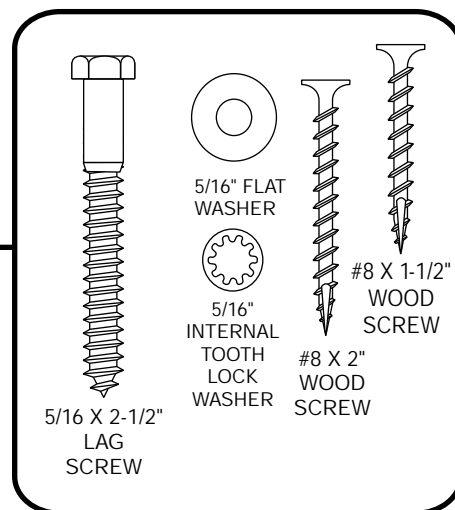

STEP 42

Attach three M9 Wall Boards to inside of H11 Wall Rails on backside of Lower Deck using 1-1/2" Wood Screws spacing approximately 2" apart.

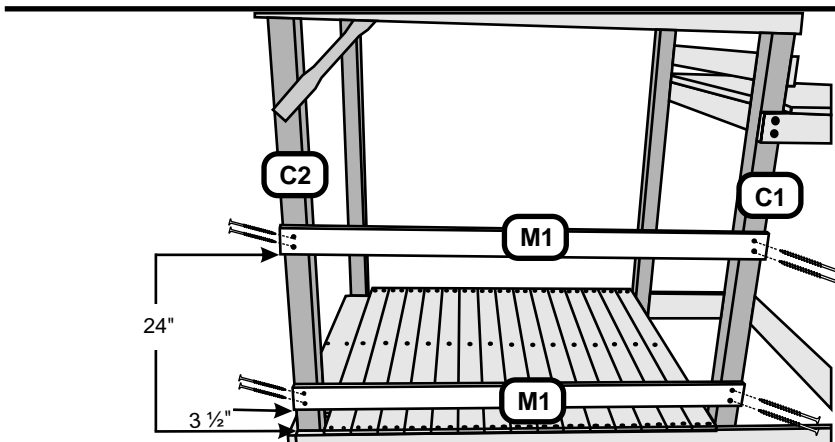

STEP 43

Attach M1 Bottom Wall Rail to C2 and C1 Posts flushing M1 to outside of C2 Posts. Measure up 3-1/2" from G1 Baseboard at front of Set and mark C2 and C1 Posts. Attach M1 with mark to bottom of Rail using 2" Wood Screws. Now measure up 24" from G1 Baseboard and mark Post again. Place bottom of M1 Rail with mark and attach to C2 and C1 Posts using 2" Wood Screws.

M4 Wall Rail * 4 Holes * 2 Req.
11/16 x 3-3/8 x 45-3/4 [1.74 x 8.57 x 116.21]

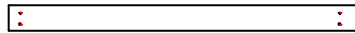

M9 Wall Board * 4 Holes * 23 Req.
11/16 x 3-3/8 x 23 [1.74 x 8.57 x 58.42]

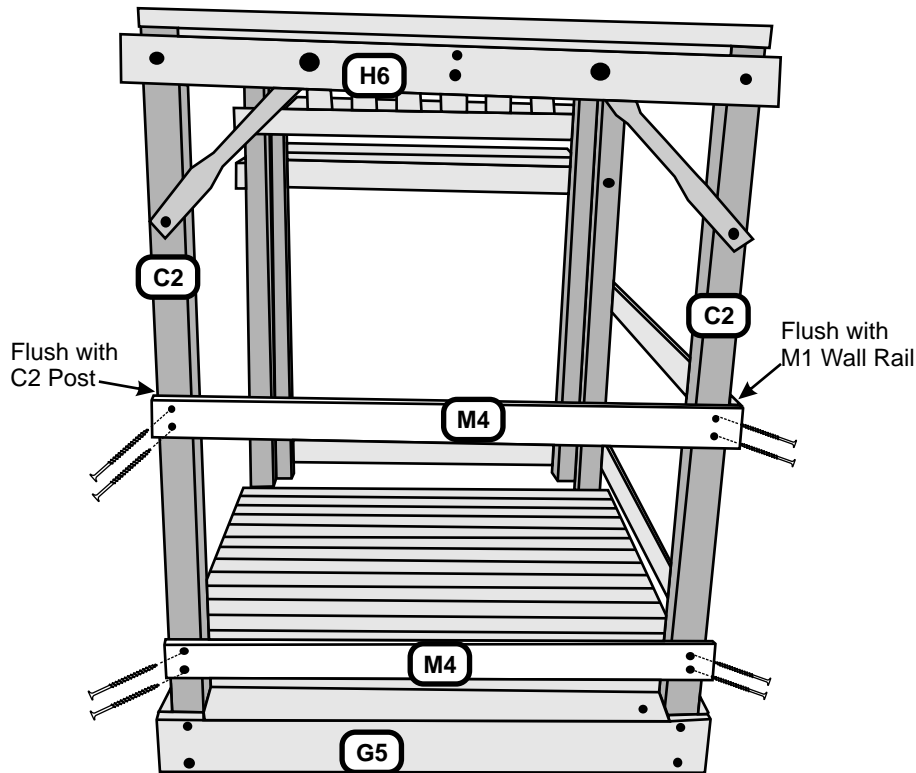
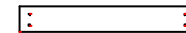

STEP 44

Attach M4 Wall Rails, noting pre-drilled holes in M4 Rail at 1-1/2" from edge towards C2 Post at backside of Set. Flush M4 to outside of M1 Wall Rails and fasten to C2 Post using 2" Wood Screws. Now level across to the other C2 Post and attach there with 2" Wood Screws.

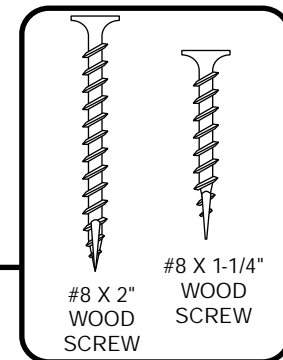

#8 X 2"
WOOD
SCREW

#8 X 1-1/4"
WOOD
SCREW

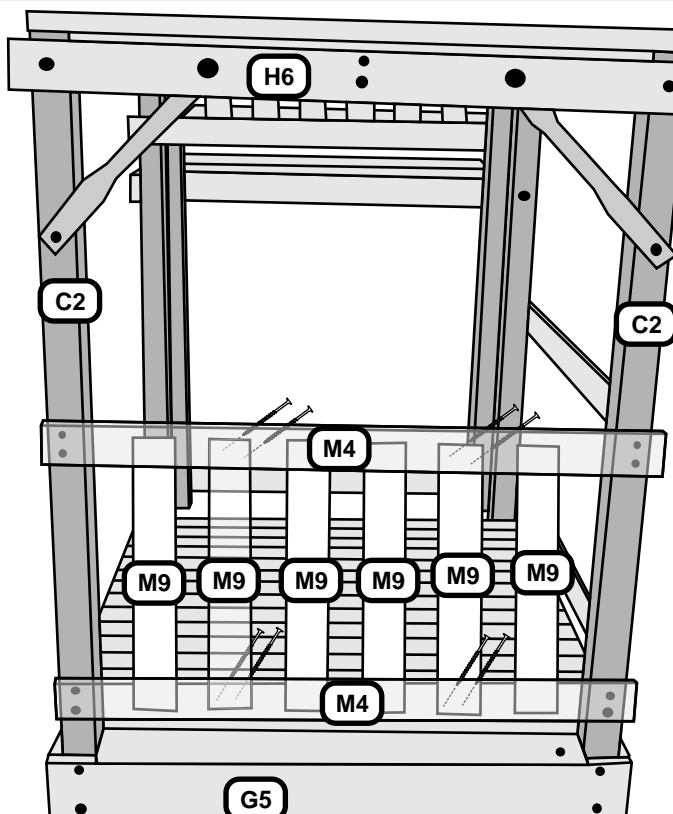

STEP 45

Attach six M9 Wall Boards to inside of M4 Wall Rails approximately 2-3/4" apart using 1-1/4" Wood Screws.

M9 Wall Board * 4 Holes * 23 Req
 11/16 x 3-3/8 x 23 [1.74 x 8.57 x 58.42]

E1 Entry Ladder Rail * 4 Holes * 1 Set Left & Right Req
 1-3/8 x 3-3/8 x 52 [3.49 x 8.57 x 132.08]

M11 Entry Ladder Support * 4 Holes * 1 Req
 11/16 x 3-3/8 x 16 [1.74 x 8.57 x 40.64]

15 1/4" METAL DOWELS
 4 REQUIRED
 Y28

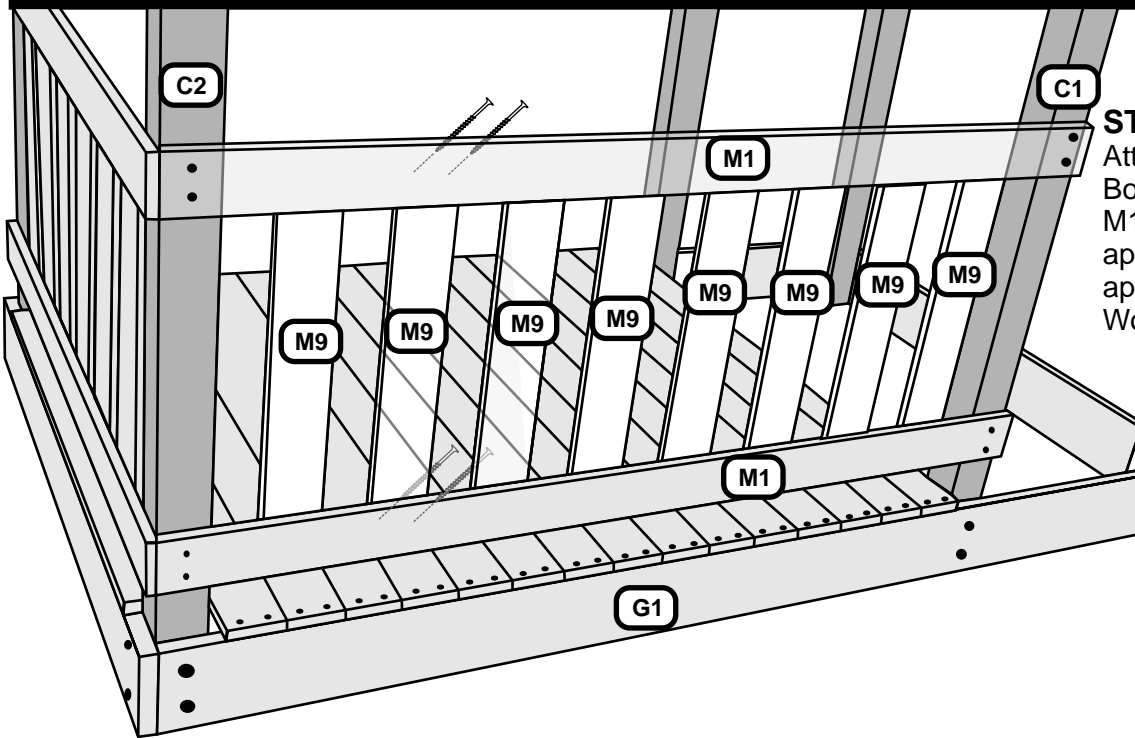
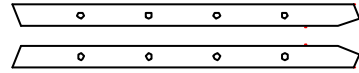

STEP 46

Attach eight M9 Wall Boards to the inside of M1s spacing approximately 2-3/4" apart, again using 1 1/4" Wood Screws.

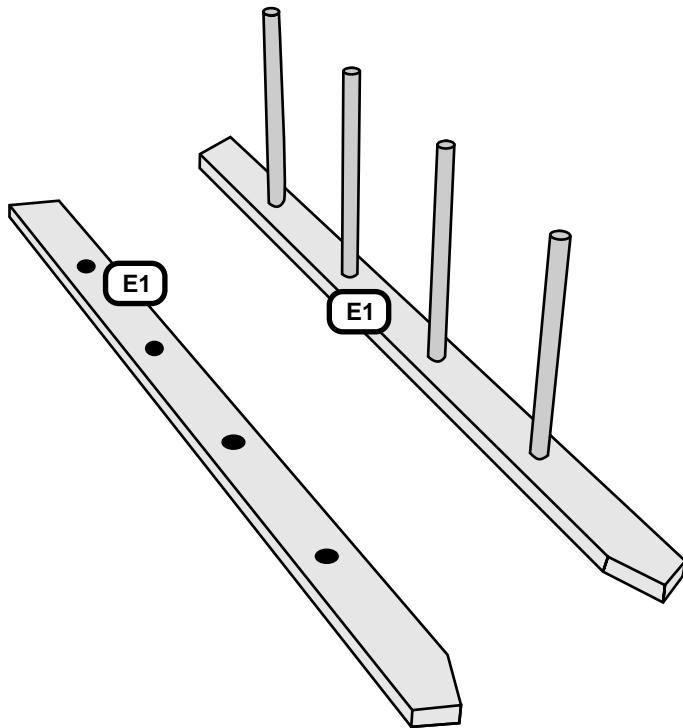
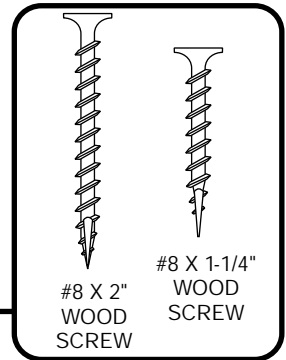

Step 47

Placing Entry Ladder Rail E1, either left or right, flat on ground, drive 15-1/4" Metal Dowels, using Pounding Block, into Rail. Then place opposite Ladder Rail, lining up Dowels, using Pounding Block, drive together so that Entry Ladder Rails are 16" apart outside to outside. Then attach M11 Entry Ladder Back to inside of Ladder Rails measuring up from bottom 1/8" and fastening with 2" Wood Screws.

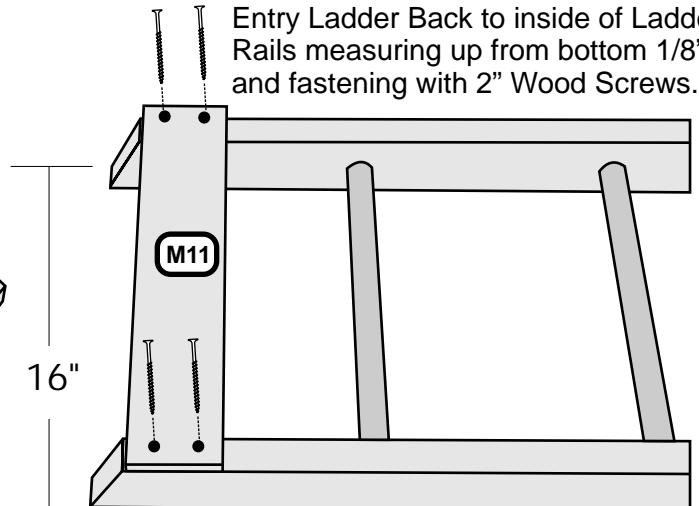

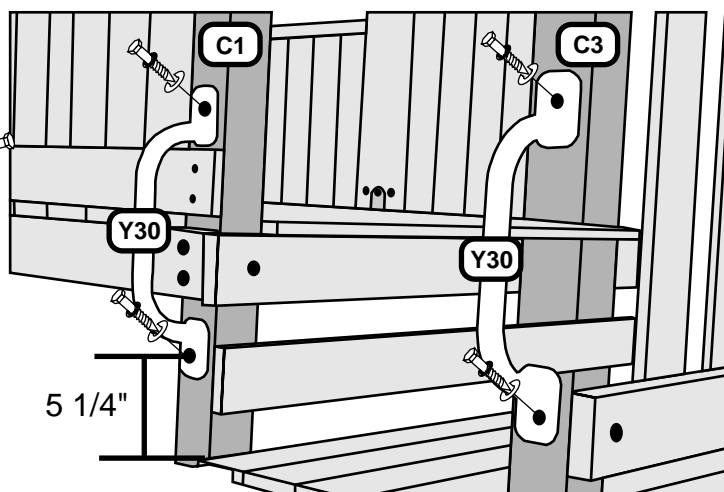
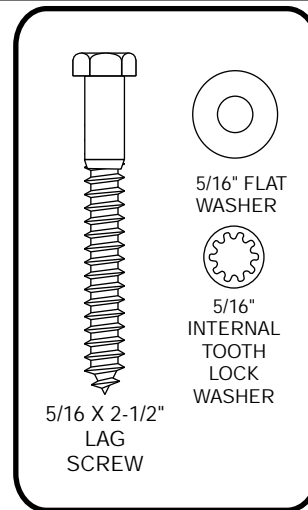
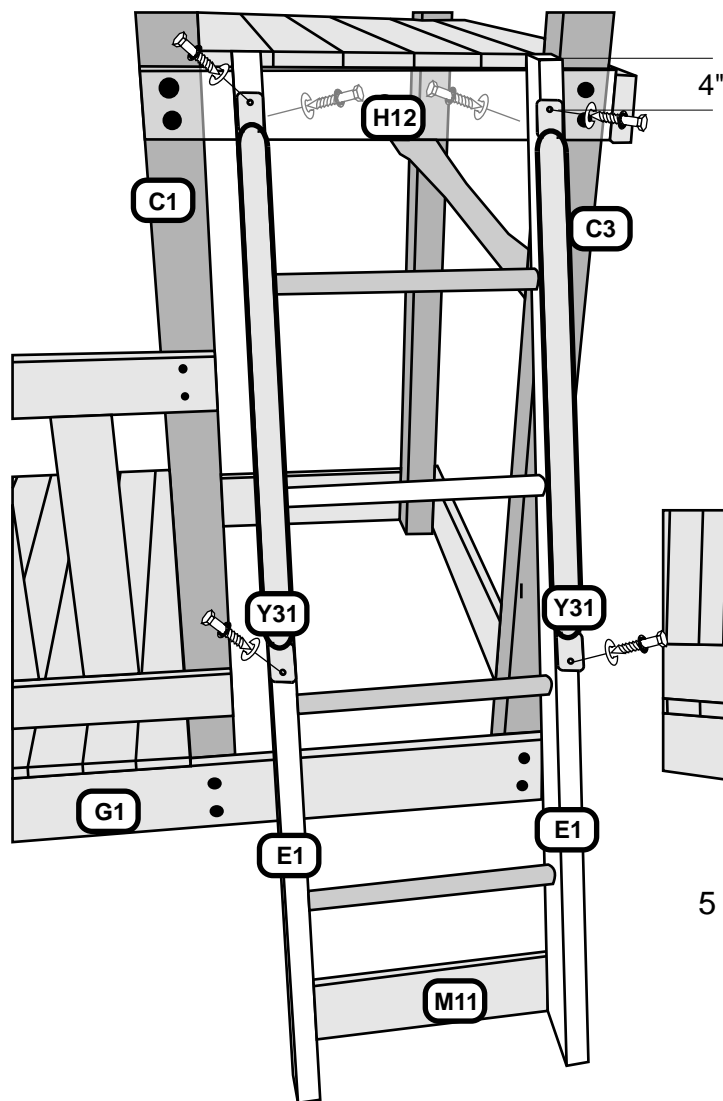

STEP 48

Stand Entry Ladder up and line up Ladder Rails with pre-drilled holes and H12 Floor Rail and using 3/16" drill bit pilot hole Entry Ladder Rails. Then fasten ladder assembly using 2-1/2" Lag Screws, Internal Tooth Lock Washers and Flat Washers through H12 Floor Rail into Entry Ladder Rails.

At this point, attach Y31 metal grip to ladder rails. Measure down 4" from top edge and drill a pilot hole in center of the board with 3/16" drill bit. Attach handles at these points using 2 1/2" lag screw, lock washer and flat washer. Now use hole in bottom of handle as guide to pilot drill and finish attaching with 2 1/2" lag screw, lock washer and flat washer.

STEP 49

Measure up 5-1/4" from H12 Floor Rails and mark center of C1 and C3 Posts. Pilot drill using 3/16" drill bit. Now Attach Y30 Metal Hand Grips to each Post with 5/16 x 2-1/2" Lag Screws, Internal Tooth Lock Washers and Flat Washers. Using hole in Y30 Hand Grip in top as guide, pilot drill and finish attaching with 2-1/2" Lag Screws, Internal Tooth Lock Washers and Flat Washers.



ID PLATE

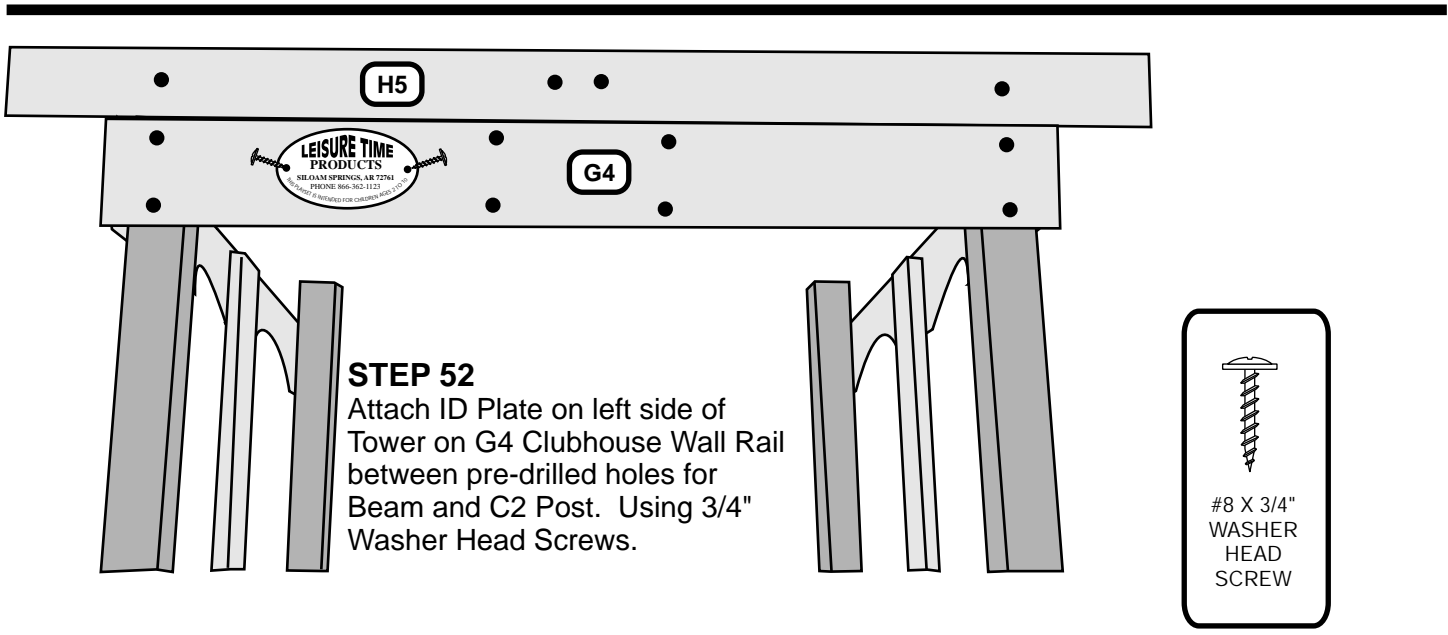

5007 Next Generation Tower is now finished.

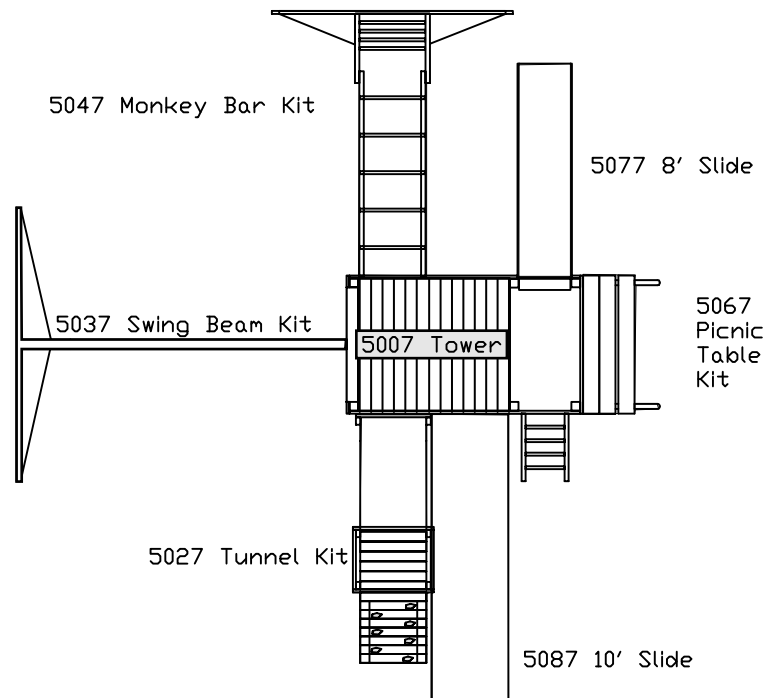

Here is a layout for Accessories that you may add to your Tower

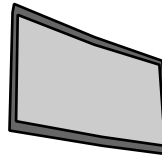

5007
GREEN MESH
WINDOW
13x23

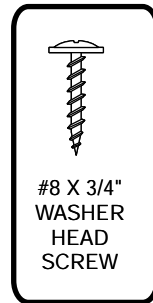
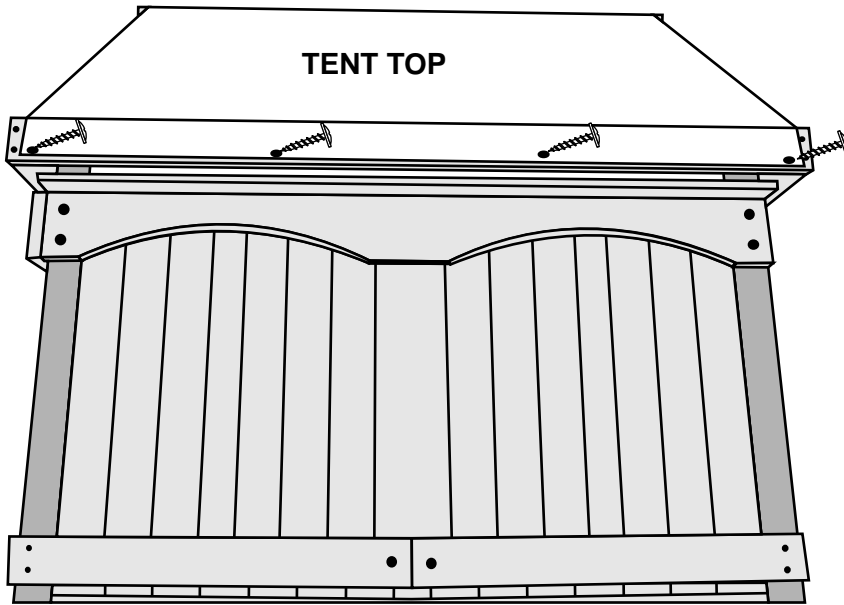

STEP 50

Attach Tent Top placing over Roof Support and attaching to Front and Back Roof Rails using 3/4" Washer Head Screws. Pull taut to one side towards bottom of Roof Rail, then pull to other side and finish attaching.

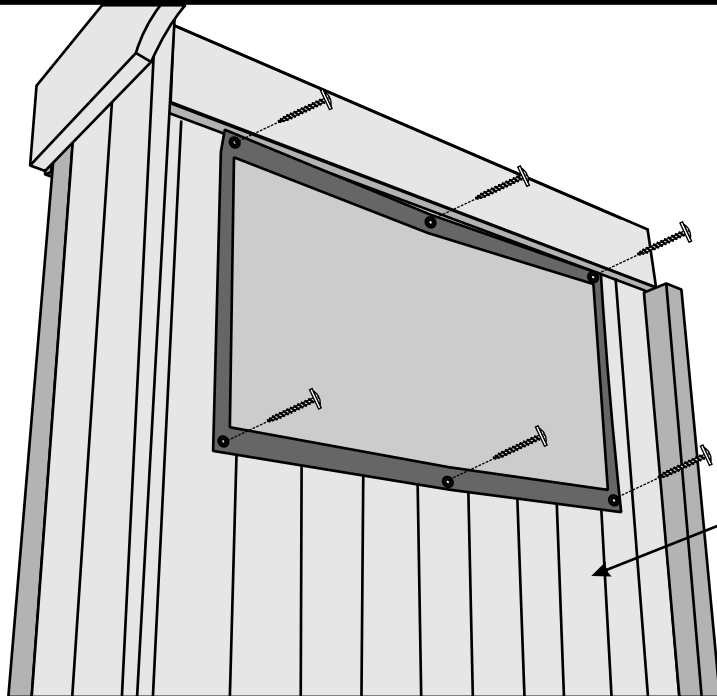

STEP 51

Install Window Mesh at top and bottom inside of Window using 3/4" Washer Head Screws.

Inside Tower

#8 X 3/4" WASHER HEAD SCREW

MAINTENANCE

REQUIRED PERIODIC MAINTENANCE

All outdoor wooden products, including Playground, Inc products, require routine inspection and regular maintenance. After installation, a follow-up inspection should take place after one week and twice a month thereafter for the remaining life of your play products. Maintenance should be performed at any time it is deemed necessary. As a general rule, major maintenance (wood refinishing) should be performed at twelve month intervals from the date of installation. Inspect and perform maintenance based on the following checklist.

Major wood parts: inspect for splintering and structural defects. If necessary, lightly sand and refinish with an exterior water repellent stain.

Hardware: inspect for tightness. Be certain that hardware is firmly against, but not crushing the wood. Over-tightening hardware crushes wood fibers and splits wooden components and could result in the bolt threads extending beyond the wood and presenting a severe safety hazard. If splintering has occurred from over tightening, larger washers can be purchased at your local hardware store and installed under the bolt head. Be sure to reuse or replace your lock washers.

If over-tightening has caused the bolt threads to protrude beyond the wood surface, replace the bolt with a shorter one that will not protrude. These bolts are standard items and can be purchased at your local hardware store.

Swing hangers: check to insure correct installation. Make sure that the bend of the swing hanger is positioned tightly against the stop washer and the ladder or swing beam. The axis of the swing hanger bushing must be perpendicular to the swing motion. If squeaking occurs, the nylon bushings can be sprayed with WD-40 or other household lubricant. Oil all metallic moving parts monthly during the usage period.

Check swings seats, ropes, cables, and chains monthly during usage season for evidence of deterioration. Replacement should be made in accordance with manufacturer's instructions.

Metal components: sand rusted areas on painted components and repaint using a non-lead based paint meeting the requirements of Title 16 CFR Part 1303.

Winterizing Your Play Set: remove plastic swing seats, trapeze bar, slide, and other plastic components and take indoors or do not use when the temperature drops below 20° F.

In the event that your set needs to be dismantled and disposed of due to storm damage, age, or other cause, make sure that you check your local city and state regulations or with your sanitation department for the proper method and means of disposal. Please dispose of the unit in such a way that no unreasonable hazards will exist (sharp edges, broken parts, and exposed screws) at the time it is discarded.

COMMONLY ASKED QUESTIONS AND ANSWERS

This section addresses some specific issues sometimes encountered during and after the assembly. Most are re-emphasis of items covered in detail elsewhere in this manual.

Question: Now that my playset product is assembled and installed, will I have to do anything to it?

Answer: Yes. You must provide routine inspections and regular maintenance. These procedures are covered in the "required periodic maintenance" section.

Question: How often should my assembled playset product be inspected?

Answer: An initial inspection should take place one week after installation and twice a month thereafter for the remaining life of your playset product.

Question: When should the necessary maintenance be performed?

Answer: Generally speaking, at the beginning of each season or as often as may be deemed necessary from an inspection. Major maintenance (primarily a thorough inspection and re-staining) should be performed at twelve-month intervals from the date of installation.

Question: How do I know when my playset product needs refinishing?

Answer: If water is absorbed into the wood, it's time to refinish your product. If, however, water beads and rolls off the wood, surfaces are protected.

Question: Why does it seem that my playset product is developing cracks?

Answer: The correct terminology for what appears to be cracks is "wood checks". A check is the radial separation of wood fibers running with the grain of wood caused by varying temperatures and moisture conditions. These checks will develop on the surface and end grains of the wood as an unavoidable aspect of the natural weathering process of all wood exposed to the elements. Checks occur after the wood has been wet, and outside surfaces dry faster than inside surfaces. Checks mainly affect the aesthetics of your play products and not its strength or durability. An exterior water repellent stain slows down the checking process because it reduces the amount of water that penetrates the wood.

Question: Why is there so much movement in my play product, especially the top supports? It looks as if the wood will break?

Answer: Because the structure is wooden rather than concrete or steel, movement is not only natural, but required. We have a saying... "if the branch doesn't bend, it will break." your play product has been designed to accommodate as many children as there are play positions. We recommend a maximum of 150 lbs. per child for play activities designed for individual use, and 120 lbs for multiple use activities. Please remember that your play product has been engineered for children 2 to 10 years old.

Question: Why is my play product rocking?

Answer: Rocking is caused by uneven ground under the base pieces. After a short period of time, your play product should settle into place and the ground stakes will provide proper stability. However, if rocks or roots surface under the base support pieces, these protrusions must be removed or the play product relocated to another area in order to eliminate rocking.

Question: *Why is my play product leaning (racking)?*

Answer: Leaning occurs in play products installed on uneven ground. Realignment will be necessary and is covered in the "required periodic maintenance" section of this manual

Question: *What can I do about squeaking swing connector hangers?*

Answer: To eliminate the squeak, spray the nylon bushings with WD-40 or other household lubricant. Some families like the squeaking as it allows them to hear where the children are playing.

Question: *Why is the wood splintering under the bolts when I tighten the hardware?*

Answer: Wood will splinter when compressed. The compression caused by over-tightening fractures wood fibers and is an indication that you are cranking down too hard on the hardware. If splintering has occurred, we recommend that you purchase larger diameter flat washers to install under the head of the bolts.

Question: *Why does my play product have mold growing on it? What can I do to remove it and keep it clean of mold and mildew?*

Answer: Because the structure is wooden rather than concrete or steel, in areas of high humidity mold and/or mildew may occur. A solution of 1 part bleach, 2 parts water applied with a sponge should clean the problem areas. Once the solution is dry, a water sealant should be applied to the entire swingset.

Question: *What if my ground stakes won't go in the ground?*

Answer: If your ground is too hard, you can purchase metal anchors from your local hardware store.

Question: *What if my ground stakes won't stay in the ground?*

Answer: This is probably caused by your ground being too soft. The ground stakes can be concreted or cemented into the ground. Do not concrete or cement the playset itself, only the ground stakes.

Question: *Who can I hire to assemble my playset?*

Answer: We do not suggest assemblers. Please refer to your yellow pages or ask for a recommendation from where you purchased your playset.

FOR YOUR RECORDS

WHERE PURCHASED: _____

PURCHASE DATE: _____ INSTALLATION DATE: _____

MODEL NAME & NUMBER MODEL #5007 • Next Generation

PLEASE READ THIS BOOKLET COMPLETELY BEFORE BEGINNING THE ASSEMBLY PROCESS.

THIS MANUAL HAS BEEN PREPARED TO HELP YOU AND YOUR FAMILY ACHIEVE FULL BENEFIT FROM YOUR LEISURE TIME PRODUCTS, INC. BACKYARD PLAYSET. IT CONTAINS HELPFUL INFORMATION CONCERNING ASSEMBLY PREPARATION, INSTALLATION PROCEDURE, REQUIRED MAINTENANCE, REPLACEMENT PARTS, AND SHOULD THE SITUATION OCCUR, THE PROCEDURE FOR FILING A WARRANTY CLAIM.

PLEASE VALIDATE YOUR WARRANTY BY COMPLETING THE WARRANTY INFORMATION CARD AND RETURN IT TO US WITHIN 30 DAYS OF INSTALLATION. THIS INFORMATION IS USED EXCLUSIVELY FOR INTERNAL PURPOSES AND AS A VERIFICATION IF NECESSARY.

THE WARRANTY ON LEISURE TIME PRODUCTS, INC. PLAY PRODUCTS IS VALID TO THE ORIGINAL PURCHASER AND IS NOT TRANSFERABLE. IT SHOULD BE NOTED THAT LEISURE TIME PRODUCTS, INC. CANNOT ASSUME ANY RESPONSIBILITY FOR MODIFICATION, OR ACCESSORIES ADDED TO THIS PRODUCT OTHER THAN THOSE MANUFACTURED AND SOLD BY LEISURE TIME PRODUCTS, INC.

THIS PRODUCT HAS BEEN DESIGNED FOR RESIDENTIAL USE ONLY. THE WARRANTY BECOMES VOID WHEN USED IN A DAYCARE, PRESCHOOL, NURSERY SCHOOL, RECREATIONAL PARK OR ANY OTHER SIMILAR COMMERCIAL APPLICATION.

FOR WARRANTY CLAIM PURPOSES, YOU MUST RETAIN YOUR SALES RECEIPT OR OTHER MEANS OF PROOF-OF-PURCHASE. YOU SHOULD ALSO KEEP THIS BOOKLET FOR FUTURE REFERENCE. PLEASE ATTACH THE SALES RECEIPT TO THE INSIDE COVER OF THIS BOOKLET FOR FUTURE REFERENCE.

LEISURE TIME PRODUCTS, INC.: 1-YEAR LIMITED WARRANTY

It is the customers' responsibility to install and maintain their playset as instructed in the instruction manual. Subject to normal use, Leisure Time Products, Inc. warrants to the original purchaser all products to be free from workmanship defects for a period of one-year from the date of the original purchase. The warranty on Leisure Time Products, Inc. play products is valid to the original purchaser and is not transferable.

Wooden parts: All wooden parts are covered against wood rot and termite damage for 1-year from the original purchase date.

Non-wooden parts: Hardware, roped or chained accessories, slides, metal or plastic components, canvas and mesh are covered 1-year from the original purchase date.

For a complete listing of our replacement parts is available through Leisure Time Products, Inc. customer service department. Contact information: 1-866-362-1123 • Fax: (479) 524-6481 • PO Box 459 Siloam Springs, AR 72761

www.leisuretimeproducts.com • E-mail: leisuret@cox-internet.com

This warranty covers residential installations only as the product has not been designed for, nor will perform safely, in any commercial application. The warranty becomes void for when used in a daycare, preschool, nursery school, recreational park or any other similar commercial application.

This warranty provides you with specific legal rights and you may also have other rights, which vary from state to state. This warranty excludes are consequential damages. Some states do not allow the limitation or exclusion of consequential damages so the above limitations may not apply to you.

Validating your warranty

Please validate your warranty by completing the warranty information card and return it to us within 30 days of your purchase. This information is used exclusively for internal purposes and for verification, if necessary. Also retain a copy of your sales receipt or other proof-of-purchase as this will be required should it become necessary to submit a claim.

Limitations

This limited warranty does not cover labor for the replacement of the defective item; the cost of freight after 30 days from original purchase; any incidental or consequential damages, cosmetic defects which do not affect the structural integrity of the unit; items damaged due to vandalism, acts of nature, improper usage or installation; or other abnormal conditions.

DETACH HERE AND MAIL

LEISURE TIME PRODUCTS, INC. WARRANTY CARD

NAME _____

ADDRESS _____

CITY _____ ST _____ ZIP _____

PHONE (____) _____

MODEL NO./NAME _____

WHERE PURCHASED _____

DATE PURCHASED _____

RETAIL PRICE PAID _____

INSTALLATION DATE _____

PRODUCT SATISFACTION: EXCELLENT GOOD FAIR POOR
(CIRCLE ONE ABOVE)

I HAVE READ THE ASSEMBLY BOOKLET AND UNDERSTAND MY RESPONSIBILITY TO MAINTAIN MY PLAY PRODUCT AND TO INSTRUCT MY CHILDREN ON PROPER PLAY AND SAFETY PROCEDURES. I ALSO UNDERSTAND THAT ALL CHILDREN THAT UTILIZE MY PLAY PRODUCT ARE TO BE SUPERVISED AT ALL TIMES.

PARENT/OWNER _____

DATE _____

COMMENTS: _____

WARRANTY

LEISURE TIME PRODUCTS

Next Generation

DETACH HERE AND MAIL

=====

WARRANTY REGISTRATION CARD

=====

Leisure Time Products, Inc.
P.O. Box 459
Siloam Springs, AR 72761

PLACE
POSTAGE
HERE

LEISURE TIME PRODUCTS, INC.
P.O. Box 459
Siloam Springs, AR 72761
1-866-362-1123 Toll Free
Office hours: 7am - 4pm, Mon-Fri, Central Time

LEISURE TIME PRODUCTS

P.O. Box 459 • Siloam Springs, AR 72761

Part # 5037

Next Generation

SWING BEAM ASSEMBLY INSTRUCTIONS

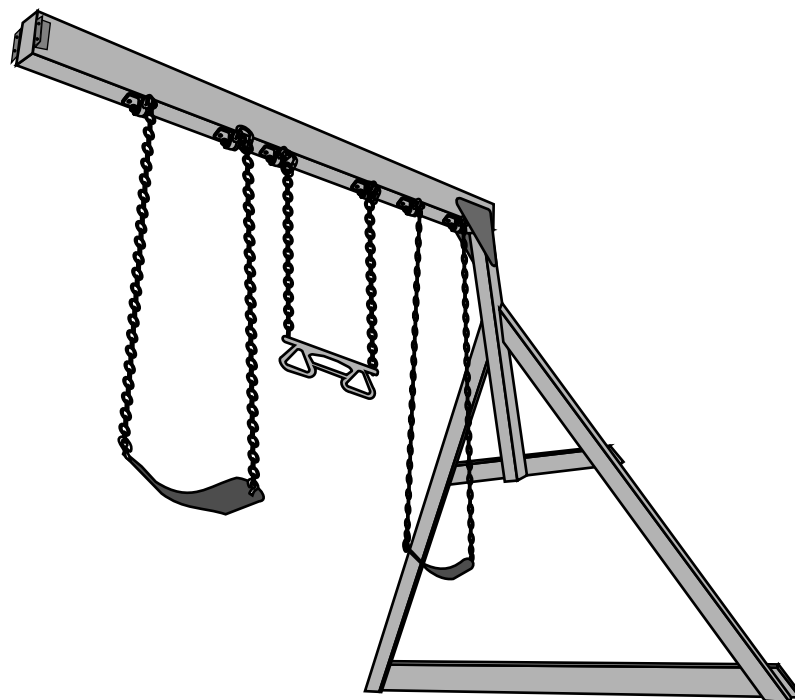

SWING HANGER

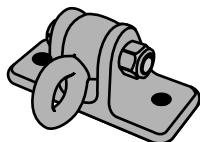

(A1) Swing Beam * 15 Holes * 3-1/4 x 5-1/4 x 94

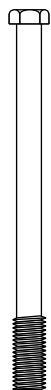
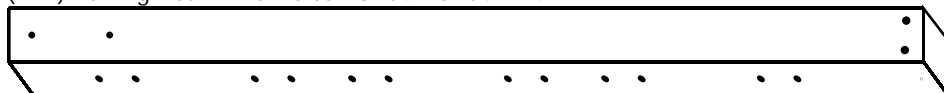

3/8 X 5-1/2"
HEX
HEAD
BOLT



3/8"
INTERNAL
TOOTH
LOCK
WASHER



SAE 3/8"
FLAT
WASHER



3/8"
SPIKE TEE
NUT

STEP 1

Attach the Swing Hangers to the Swing Beam A1 using two 3/8 x 5-1/2" Hex Head Bolts, 3/8" Lock Washers, 3/8" Washers and 3/8" Spike Tee Nuts.

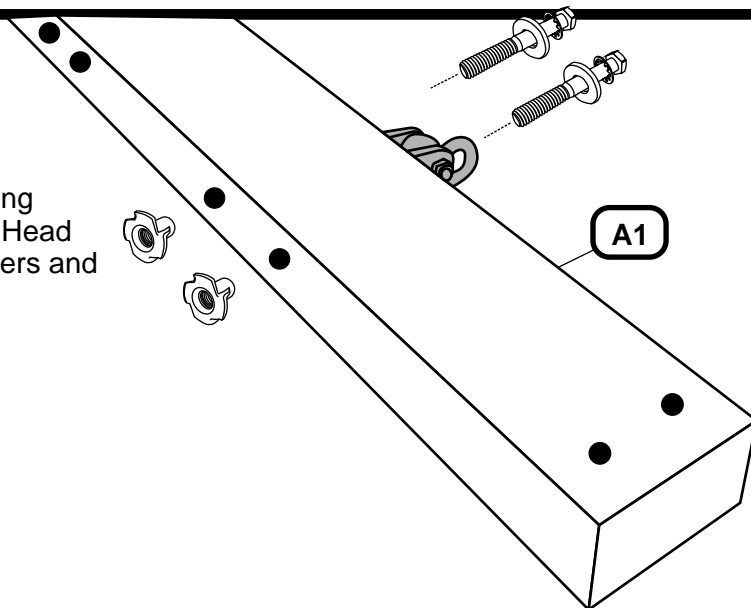

© Copyright Playground Inc

LEISURE TIME PRODUCTS

If you need assistance with parts or have assembly questions, please call Customer Service at 866-362-1123. Our regular office hours are Monday through Friday, 7:00 a.m. to 4:00 p.m. Central Time

(E1) Long Angle Brace * 1 Hole * 30° - 60° * 1-1/2 x 3-1/2 x 85

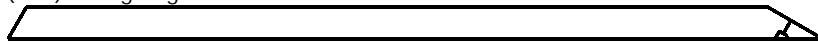

(B1) Beam End Post * 3 Holes * 3-1/4 x 3-1/4 x 47

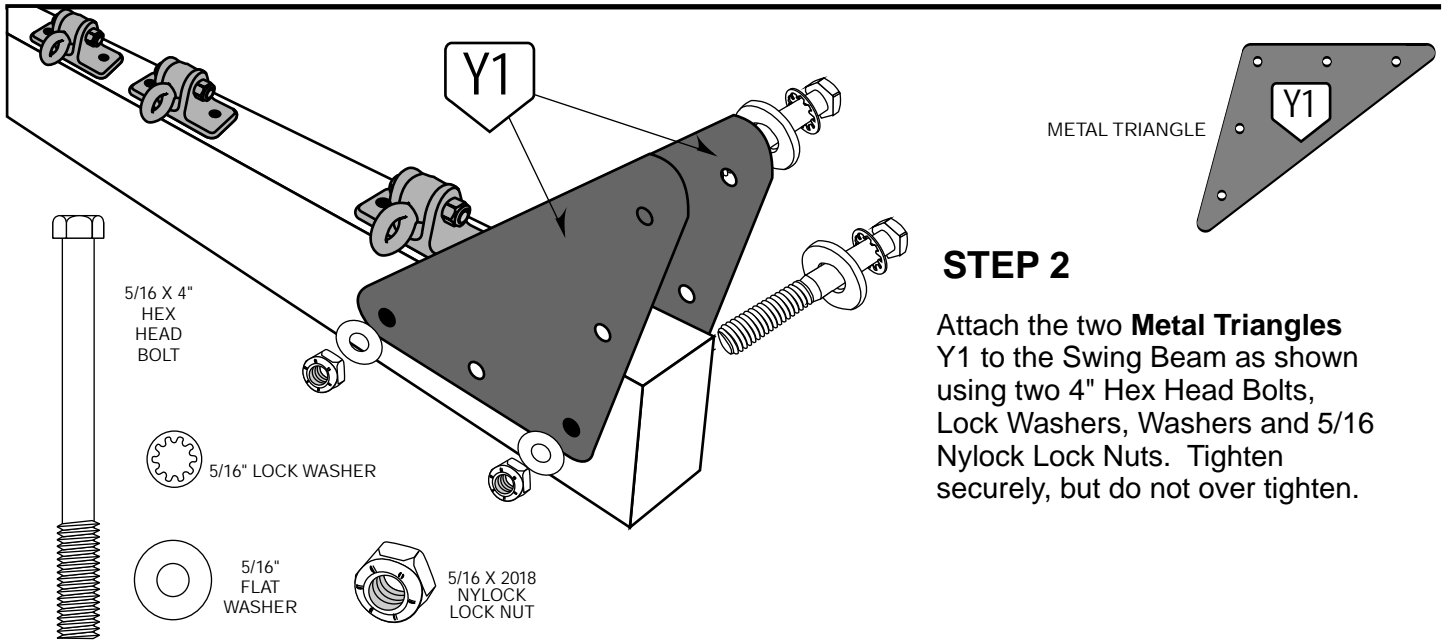
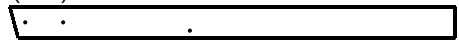

STEP 3

Thread a 3/8" Spike Tee Nut as shown in the illustration so that you can pound it into the countersunk hole on one Long Angle Brace E1. Once the Spike Tee Nut is firmly embedded in the wood at the bottom of the hole, unscrew and remove the bolt. This is the easiest way to install the Spike Tee Nuts in a countersunk hole. You only need to do this on one of the Long Angle Braces.

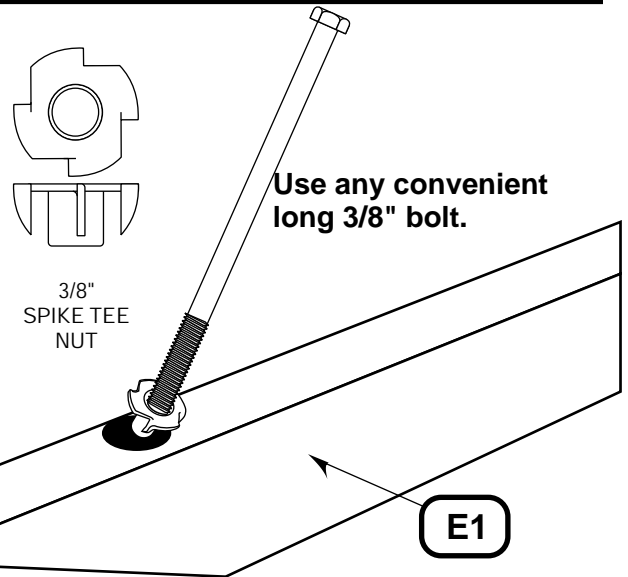

STEP 4

Attach the E1 Long Angle Braces to the B1 Beam End Post using a 3/8"x6-1/2" Hex Head Bolt, 3/8" Lock Washer, and 3/8" Flat Washer, threading the bolt through the wooden parts into the Spike Tee Nut installed in Step 3. Tighten securely, but don't over tighten.

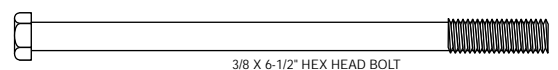
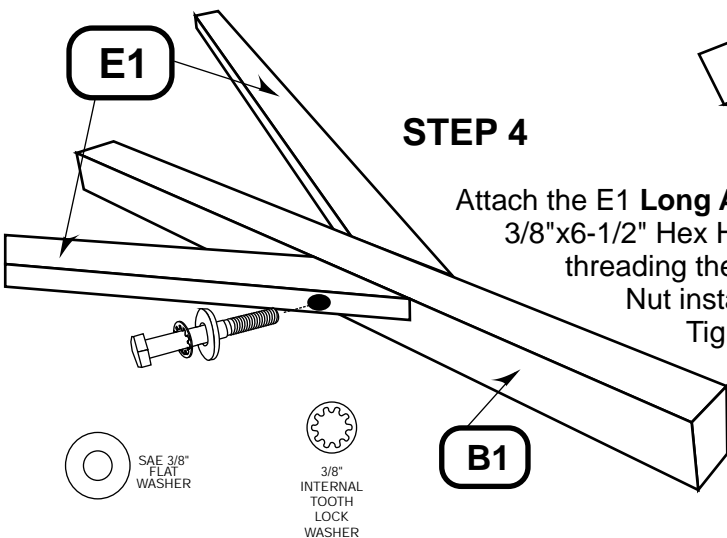

3/8 X 6-1/2" HEX HEAD BOLT

(G1) Beam Ground Board * 4 Holes * 1 x 5-1/2 x 89



(E2) Beam End Support * 4 Hole * 1-1/2 x 3-1/2 x 40-3/4



STEP 5

Pilot drill with 3/16" bit using holes in G1 as guide and attach the G1 **Beam Ground Board** to the assembly using four 2" Lag Screws, Lock Washers and Washers. The Ground Board will overhang the E1 boards, as shown in the inset illustration. Tighten securely, but do not over tighten.

NOTE HOW THE ANGLED FACE OF B1 IS FACING UP FOR THESE TWO STEPS.

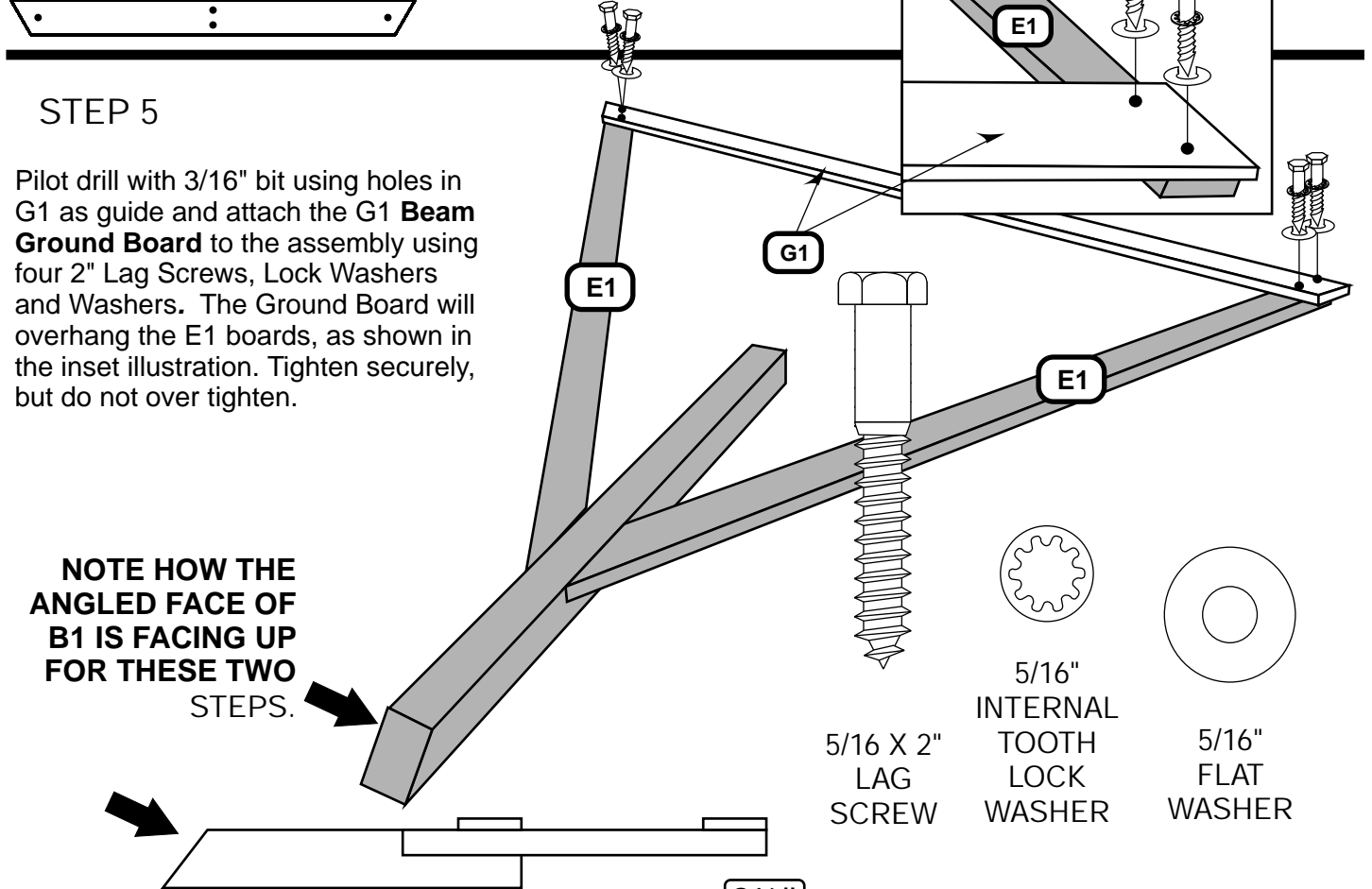

5/16" X 2" LAG SCREW
 5/16" INTERNAL TOOTH LOCK WASHER
 5/16" FLAT WASHER

STEP 6

Pilot drill using 3/16" bit and holes in E2 as guide and attach the E2 **Beam End Support** E2 to the assembly using two 3" Lag Screws, Lock Washers and Washers in the center holes into B1 and two 2-1/2" Lag Screws, Lock Washers and Washers into the E1 boards. Tighten securely, but do not over tighten.

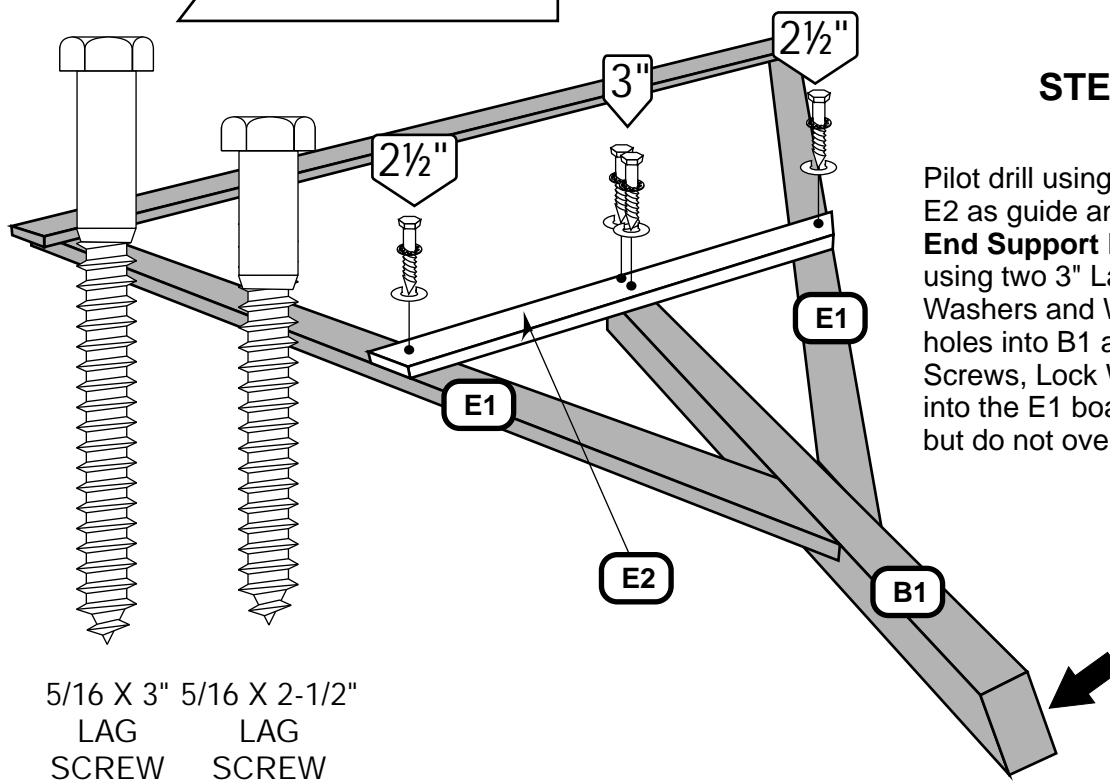

5/16 X 3" LAG SCREW
 5/16 X 2-1/2" LAG SCREW

STEP 7

Attach the support assembly to the Swing Beam with the Metal Triangles Y1 using two 4" Hex Head Bolts, Lock Washers, Flat Washers and Lock Nut.

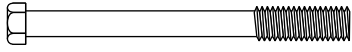

5/16 X 4" HEX HEAD BOLT

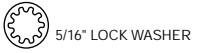

5/16" LOCK WASHER



5/16" FLAT WASHER



5/16" X 2018
NYLOCK
LOCK NUT

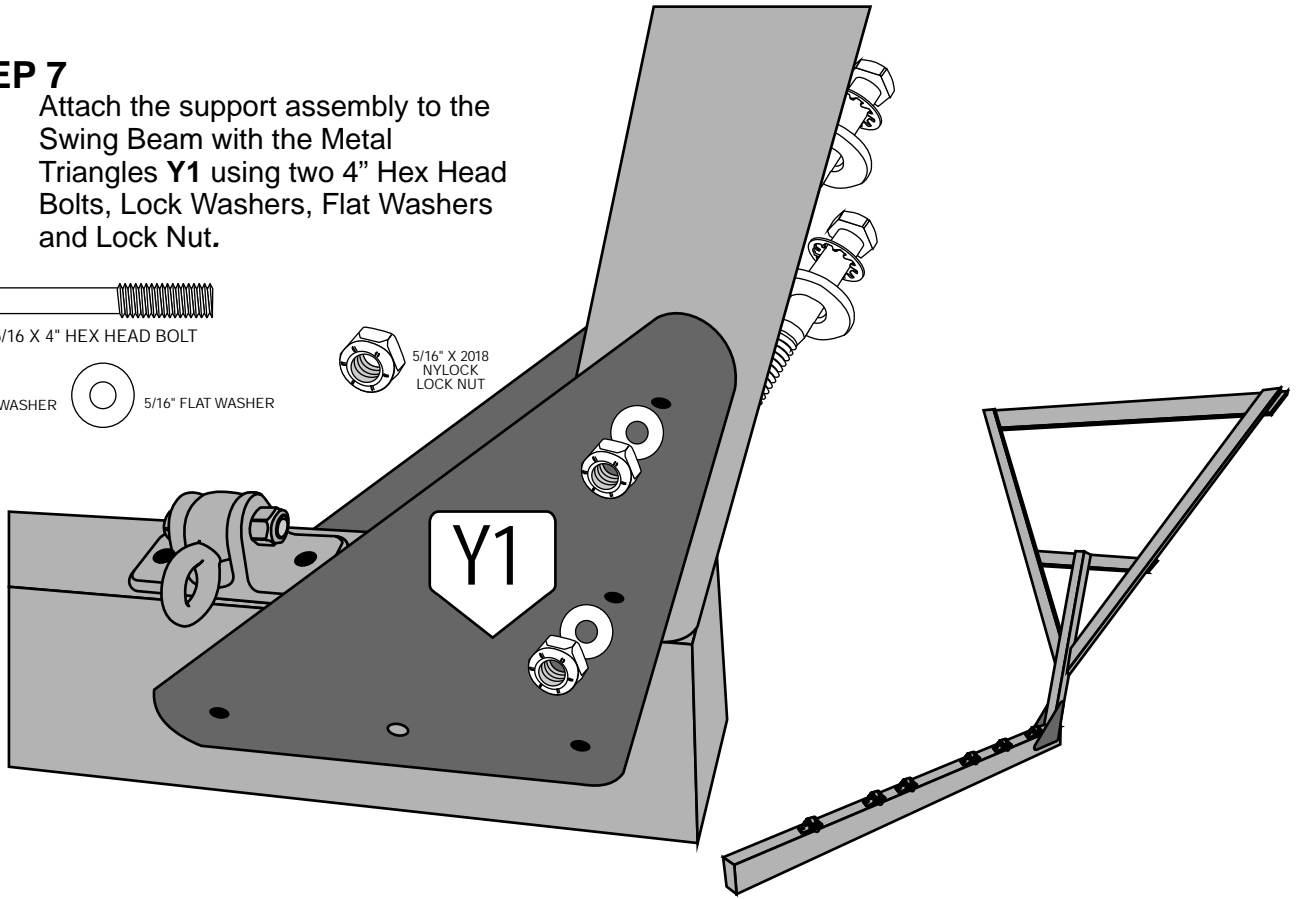

STEP 8

Attach the Y16 Swing Assembly Mounts to the end of Swing Beam using two 4" Hex Bolts, Lock Washers, 4 Flat washers and secure with two 5/16 Nylock Nuts.

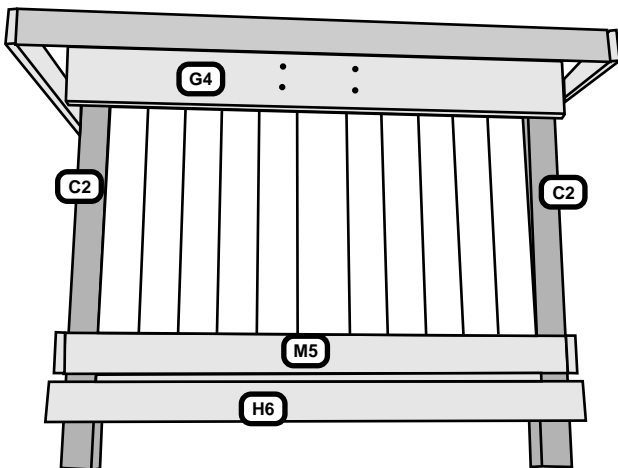
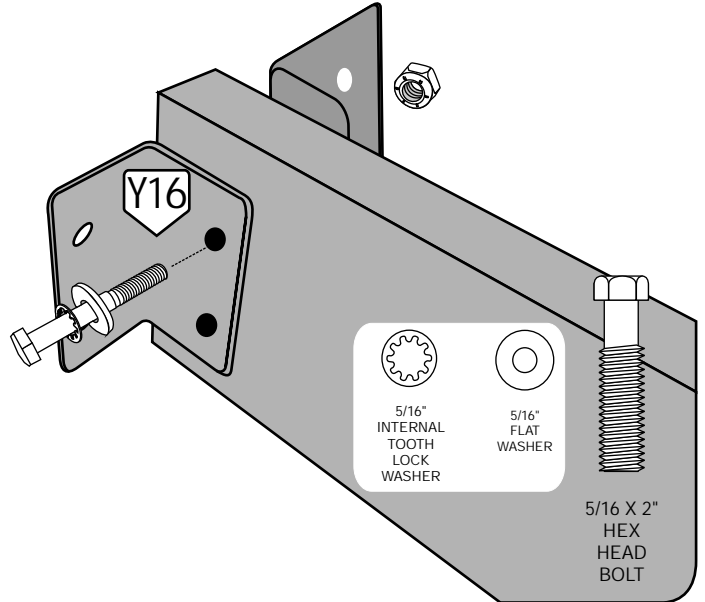

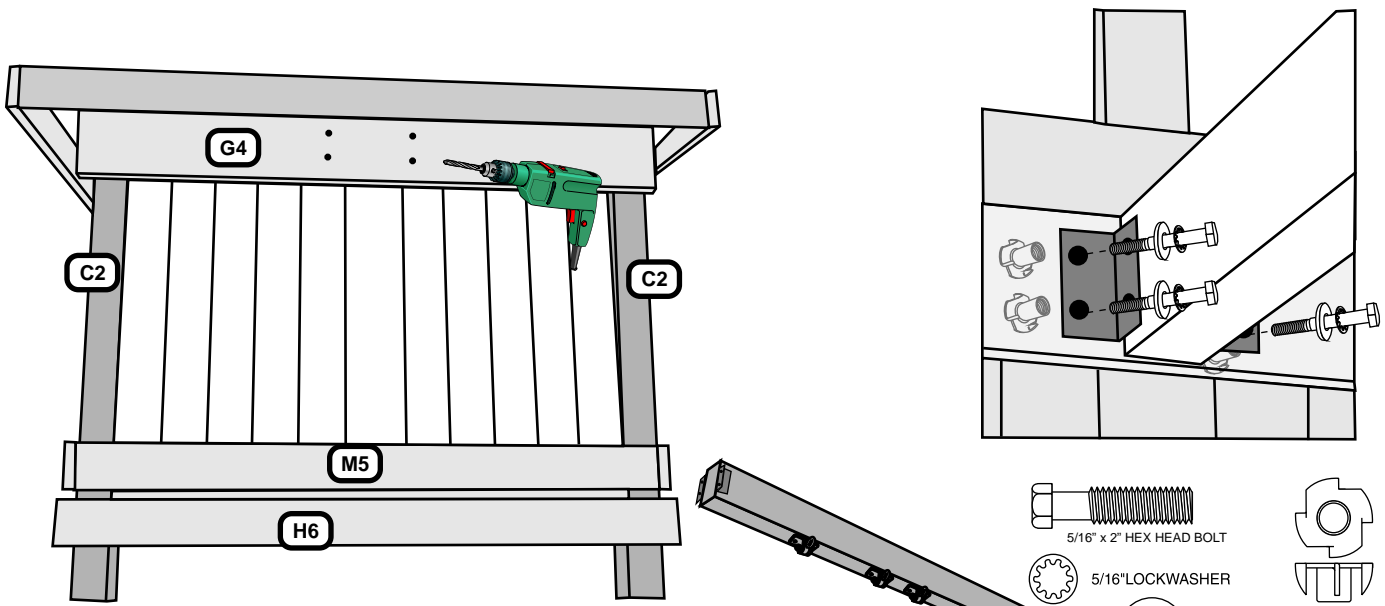

STEP 9

Using the pre-drilled holes in the G4 Club House Wall Rail as a guide, drill thru the Wall Boards using a 3/8" drill bit. Install four 5/16" Spiked T Nuts, from the inside of the Tower, into these holes.

Turn over the Swing Beam Assembly, stand it up, and line up the holes in the **Y16** Swing Beam Mount to the holes in the G4 Club House Wall Rail. Attach the Swing Beam Assembly to the Tower using four 2" Hex Bolts, Lock Washers and Flat Washers through the **Y16** Swing Beam Mount and G4 Rail. Tighten securely, but do not over tighten.

STEP 10

Metal stake installation: measure in 8" from outside edge of G1 ground board for ground for stake location. Now attach the stakes to G1 Ground Board using 1" Phillips Truss Head Bolt, two Flat Washers, Lock Washer and Barrel Nut Per Diagram at right. You will need a long screwdriver for leverage. In some cases you may need to dig a hole to install stake and cement.

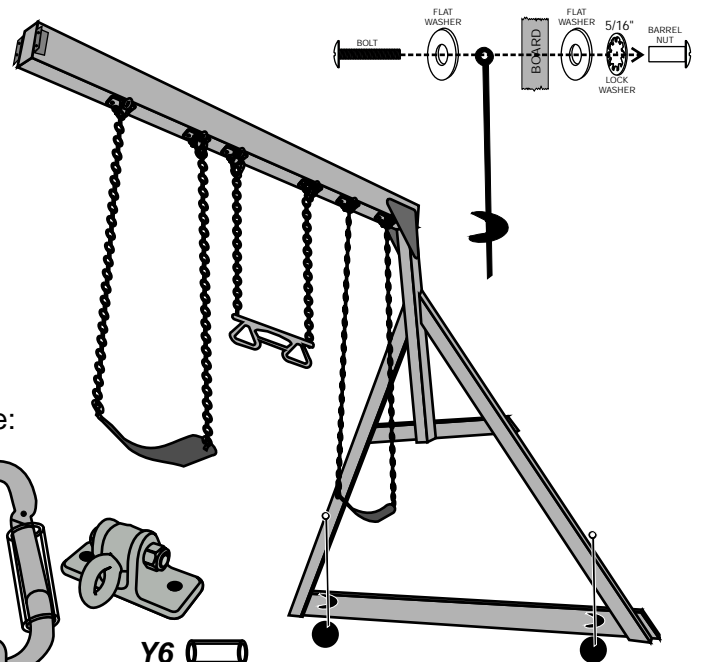

STEP 11

Hang the Swings and Trapeze with this simple procedure:

- Put all the chains on the **Carabiners Y5**.
- Hang the Swings and Trapeze as shown below
- Slip the Plastic Safety **Tubes Y6** on the Carabiner.

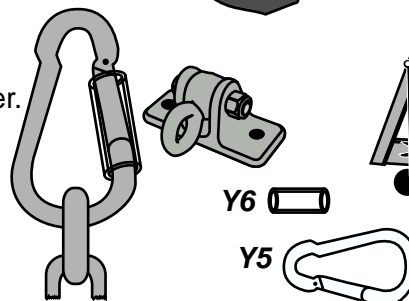

LEISURE TIME PRODUCTS

P.O. Box 459 • Siloam Springs, AR 72761

Parte # 5037

Última Generación

BARRA PARA COLUMPIO

INSTRUCCIONES DE ENSAMBLAJE

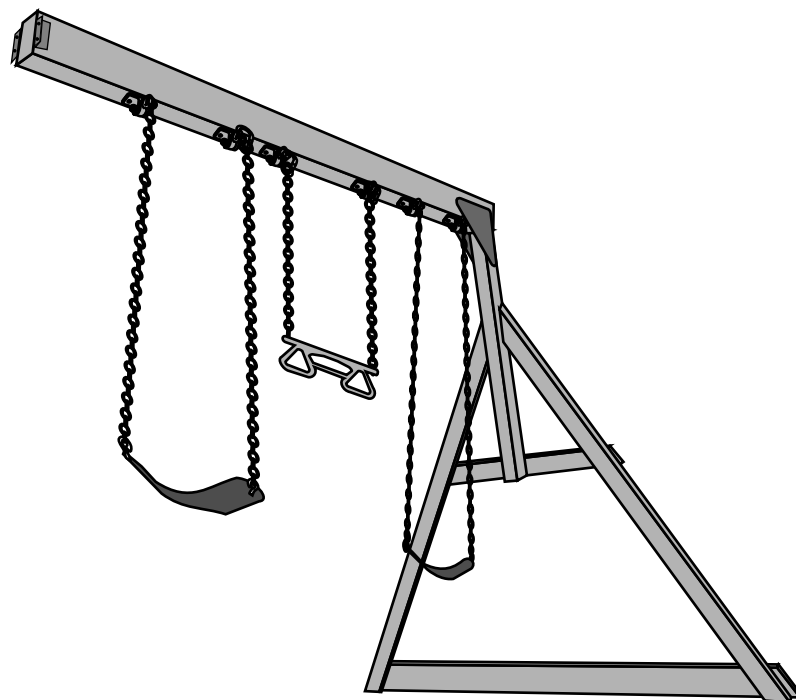

COLGADOR DEL COLUMPIO

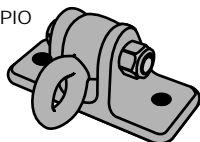

(A1) Barra para columpio * 15 agujeros * 3-1/4 x 5-1/4 x 94

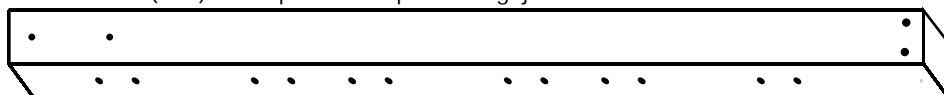

PERNO CABEZA
HEXAGONAL DE 3/8 x 5-
1/2 in. (9,5 mm x 14 cm)



ARANDELA DE
SEGURIDAD DE 3/8
in. (9,5 mm) CON
DIENTES
INTERIOS



ARANDELA
PLANA SAE DE
3/8 in. (9,5 mm)



TUERCA EN T DE
3/8 in. (9,5 mm) CON
ESPIGAS

PASO 1

Fije los colgadores de los columpios a la barra para columpio A1 utilizando dos pernos cabeza hexagonal de 3/8 x 5-1/2 in. (9,5 mm x 14 cm), arandelas de seguridad de 3/8 in. (9,5 mm), arandelas de 3/8 in. (9,5 mm) y tuercas en T con espigas.

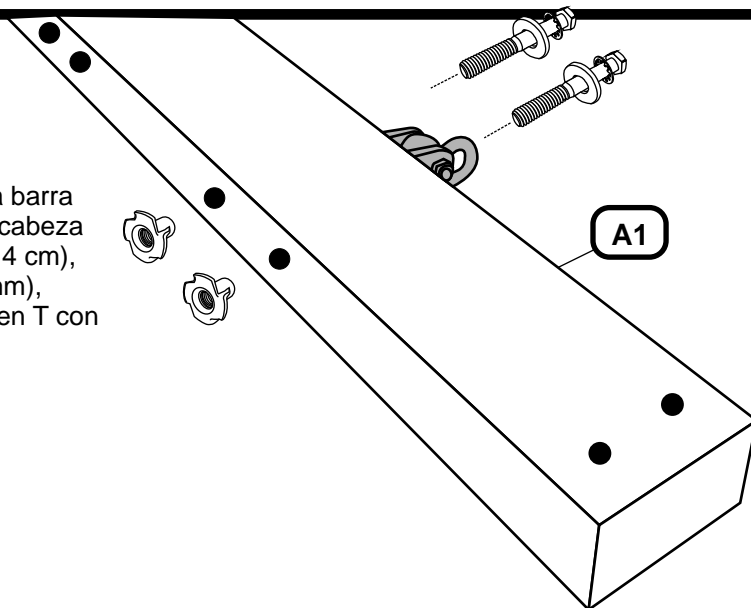

© Copyright Playground Inc

PRODUCTOS LEISURE TIME

Si necesita ayuda con las partes o tiene preguntas sobre el ensamblaje, por favor llame al Dpto. de Servicio al Cliente al 866-362-1123. Nuestras horas regulares de oficina son de lunes a viernes, de 7:00 a.m. a 4:00 p.m. Hora Central.

(E1) Refuerzo largo en ángulo * 1 agujero * 30° - 60° * 1-1/2 x 3-1/2 x 85

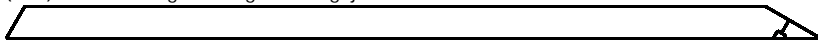

(B1) Poste para extremo de barra * 3 agujeros * 3-1/4 x 3-1/4 x 47

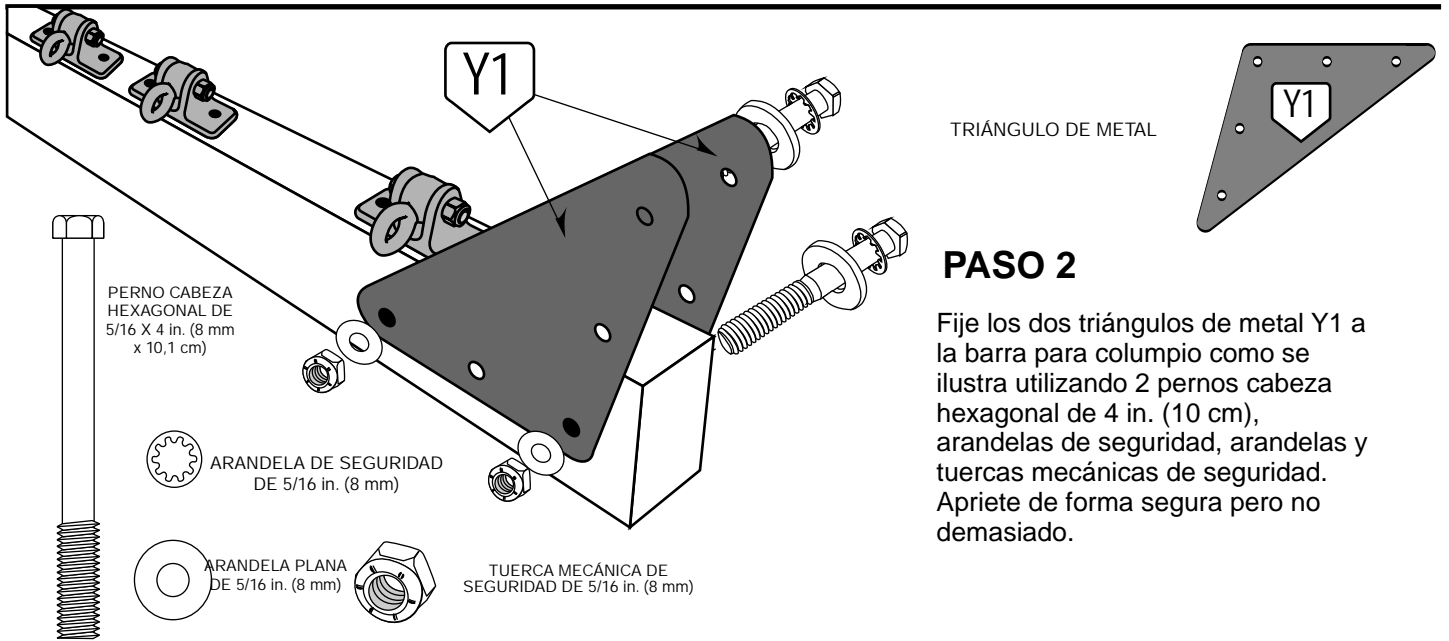
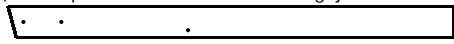

PASO 3

Introduzca una tuerca en T de 3/8 in. (9,5 mm) con espigas como se ilustra de modo que la pueda martillar para avellanar el agujero en un refuerzo largo en ángulo E1. Una vez que la tuerca en T con espigas esté firmemente introducida en la madera en el fondo del agujero, desatornillela y retire el perno. Esta es la forma más fácil de instalar las tuercas en T con espigas en un agujero avellanado. Sólo necesita hacer esto en uno de los refuerzos largos en ángulo.

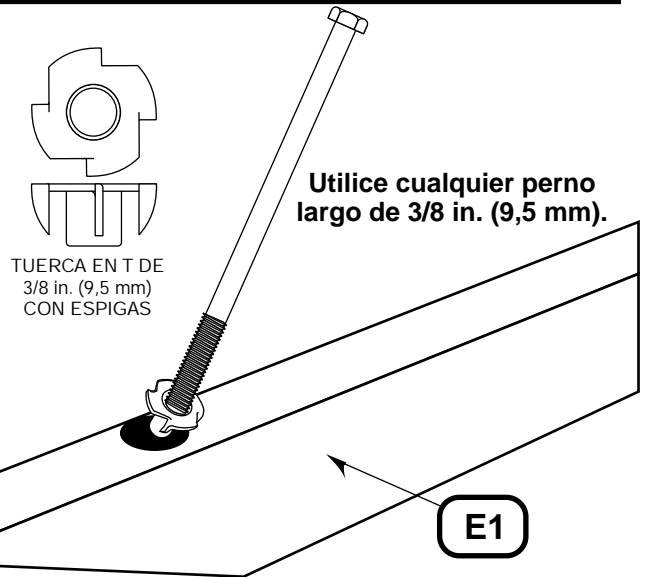

PASO 4

Fije los refuerzos largos en ángulo al poste de extremo de la barra B1 utilizando un perno cabeza hexagonal de 3/8 x 6-1/2 in. (9,5 mm x 16,5 cm), una arandela de seguridad de 3/8 in. (9,5 mm) y una arandela plana de 3/8 in. (9,5 mm), insertando el perno a través de las partes de madera en la tuerca en T con espigas del paso 3.

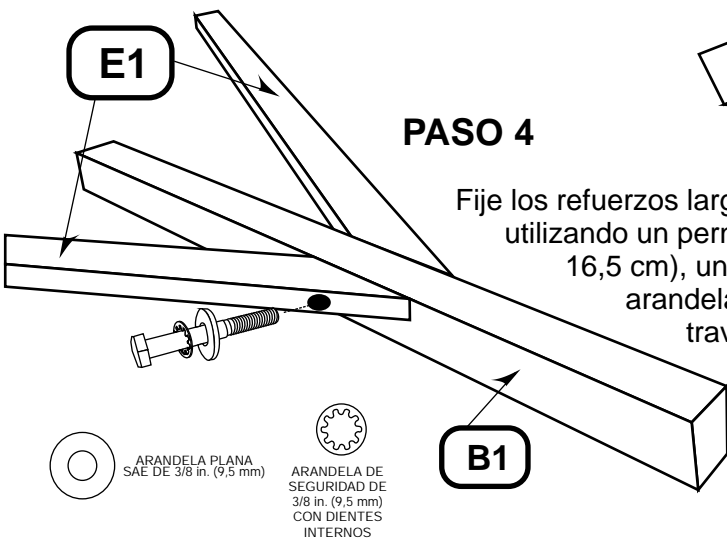

Apriete de forma segura pero no demasiado.

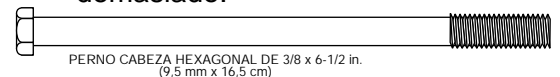

(G1) Tabla de apoyo A tierra * 4 agujeros * 1 x 5-1/2 x 89



(E2) Soporte de extremo para la barra * 4 agujeros * 1-1/2 x 3-1/2 x 40-3/4



PASO 5

Haga un agujero piloto con la broca de 3/16 in. (4,8 mm) utilizando los agujeros de G1 como guía y fije la tabla de tierra G1 al ensamble utilizando dos tornillos tirafondo de 2 in. (5 cm), arandelas de seguridad y arandelas. La tabla sobresaldrá de las tablas E1 como se ilustra. Apriete de forma segura pero no demasiado.

OBSERVE COMO LA CARA ANGULADA DE B1 ESTÁ ORIENTADA HACIA ARRIBA EN ESTOS DOS PASOS.

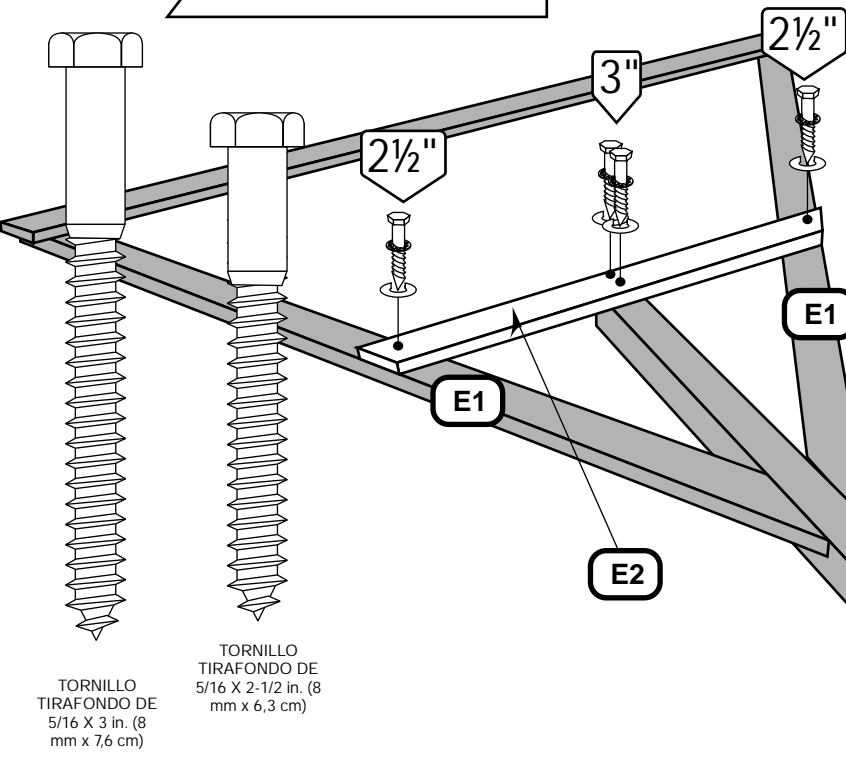
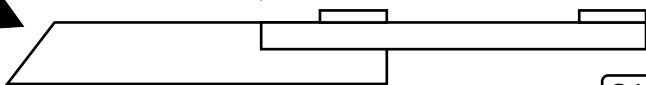

TORNILLO TIRAFONDO DE 5/16 X 3 in. (8 mm x 7,6 cm)

TORNILLO TIRAFONDO DE 5/16 X 2-1/2 in. (8 mm x 6,3 cm)

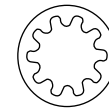

ARANDELA DE SEGURIDAD DE 5/16 in. (8 mm) CON DIENTES INTERNOS

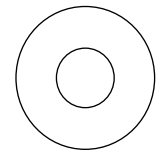

ARANDELA PLANA DE 5/16 in. (8 mm)

TORNILLO TIRAFONDO DE 5/16 X 2 in. (8 mm x 5 cm)

PASO 6

Haga agujeros piloto utilizando la broca de 3/16 in. (4,8 mm) y agujeros en E2 como guía y fije el soporte de extremo para la barra E2 al ensamble utilizando dos tornillos tirafondo de 3 in. (7,6 cm), arandelas de seguridad y arandelas en los agujeros del centro en B1 y dos tornillos tirafondo de 2-1/2 in. (6,3 cm), arandelas de seguridad y arandelas en las tablas E1. Apriete de forma segura pero no demasiado.

PASO 7

Fije el ensamble del soporte a la barra para columpio con los triángulos de metal Y1 utilizando dos pernos cabeza hexagonal de 4 in. (10 cm), arandelas de seguridad, arandelas planas y tuerca de seguridad.

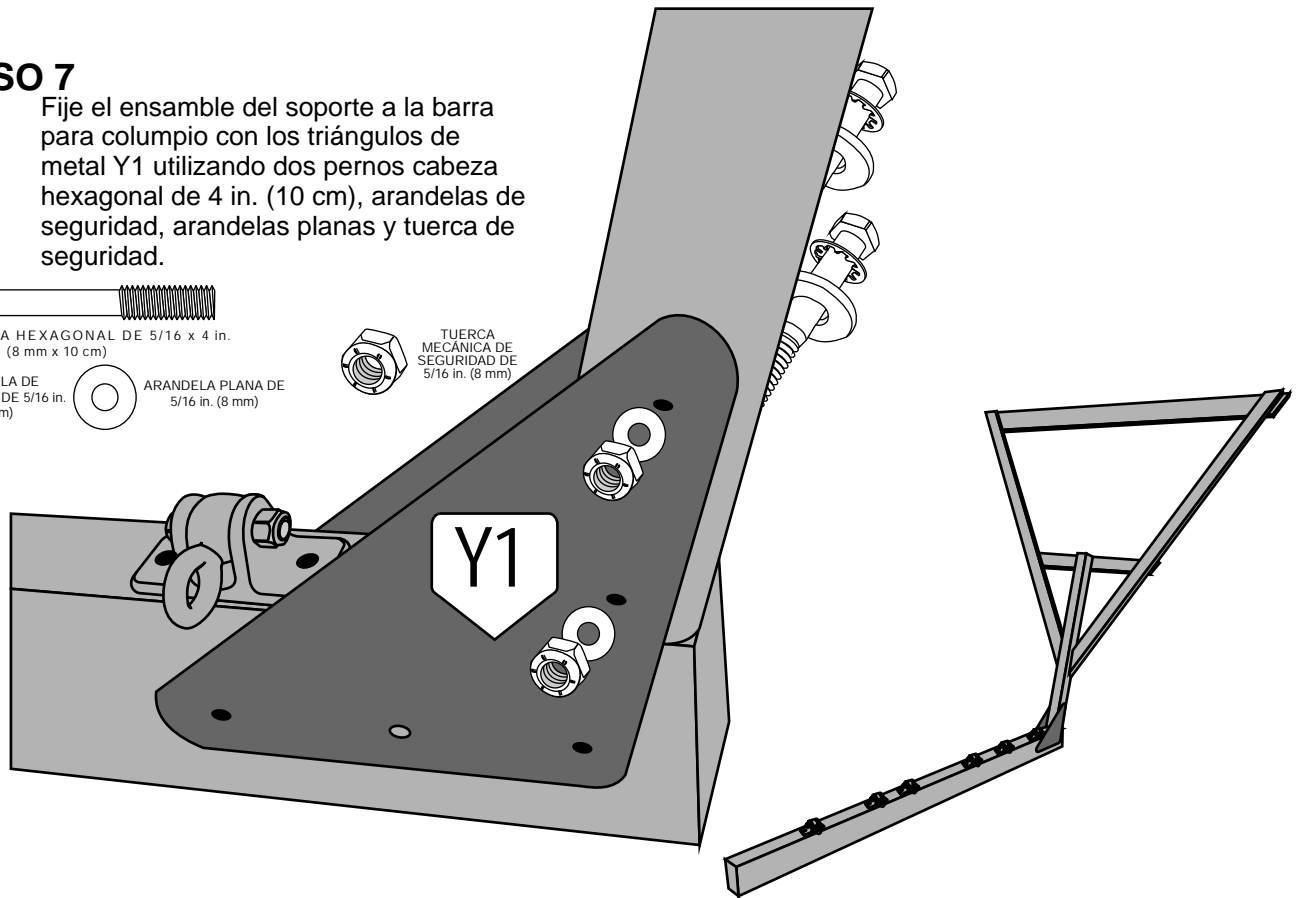
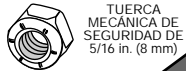
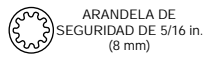
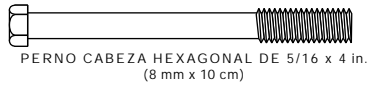

PASO 8

Fije los soportes para el ensamble de columpio Y16 al extremo de la barra para columpio utilizando dos pernos hexagonales de 4 in. (10 cm), arandelas de seguridad, 4 arandelas planas y asegure con dos tuercas mecánicas de 5/16 in. (8 mm).

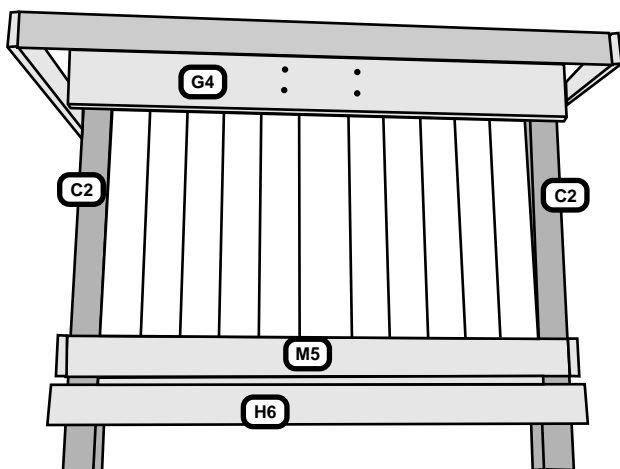
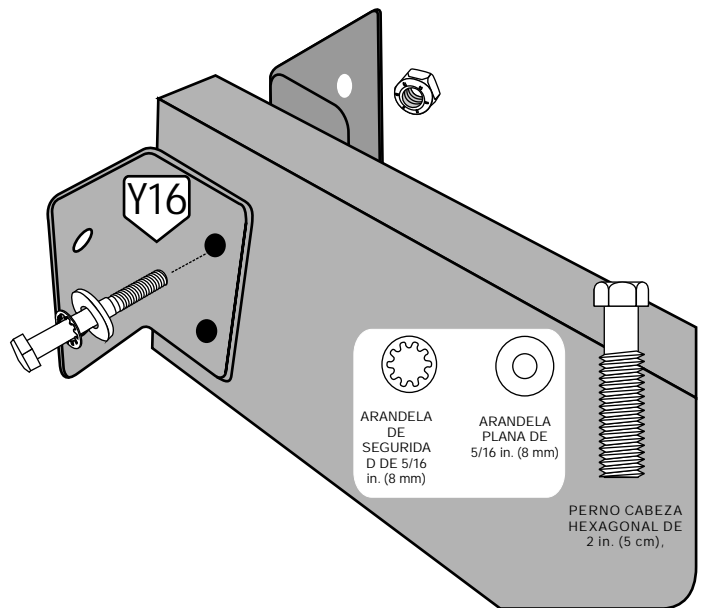

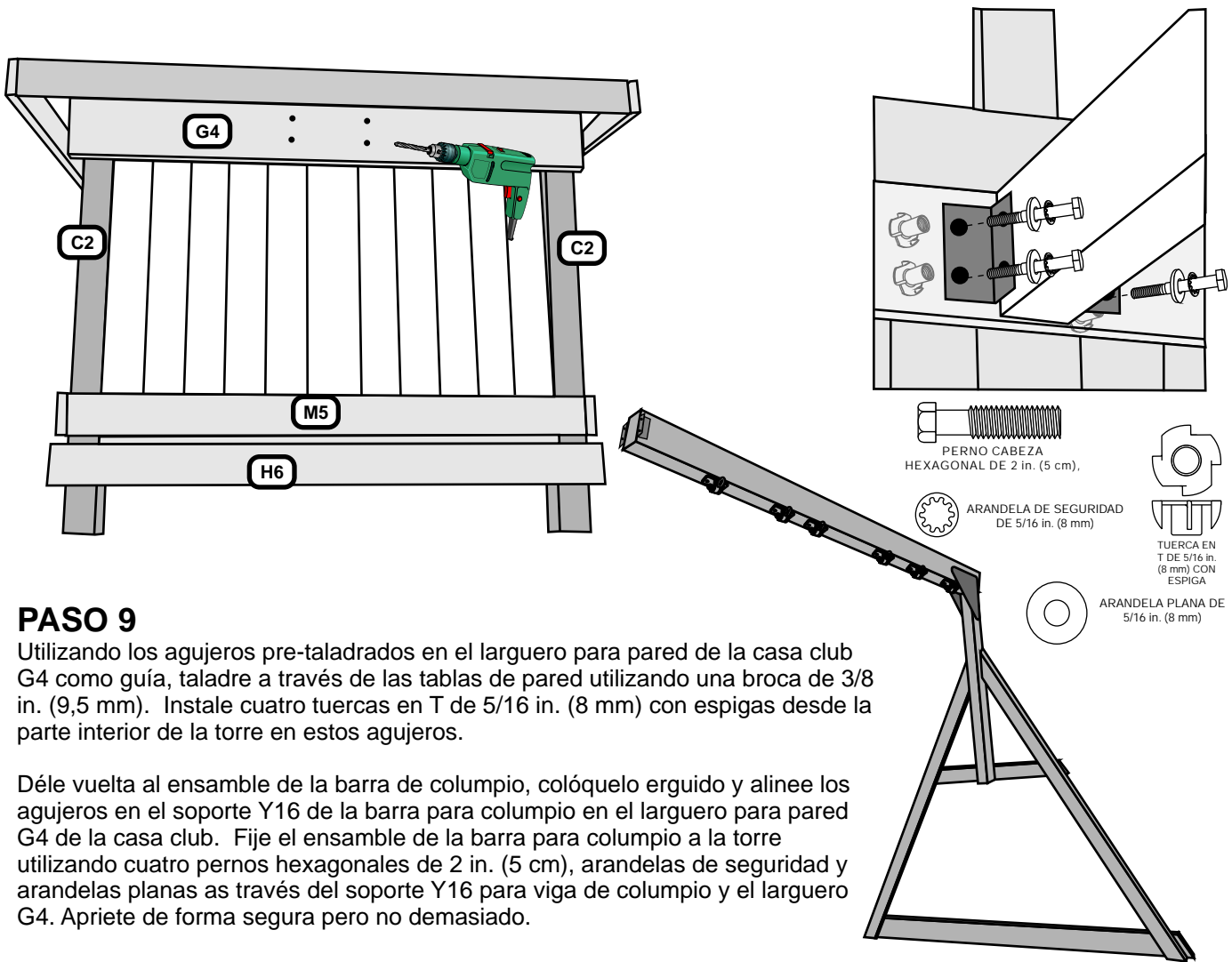

PASO 9

Utilizando los agujeros pre-taladrados en el larguero para pared de la casa club G4 como guía, taladre a través de las tablas de pared utilizando una broca de 3/8 in. (9,5 mm). Instale cuatro tuercas en T de 5/16 in. (8 mm) con espigas desde la parte interior de la torre en estos agujeros.

Déle vuelta al ensamble de la barra de columpio, colóquelo erguido y alinee los agujeros en el soporte Y16 de la barra para columpio en el larguero para pared G4 de la casa club. Fije el ensamble de la barra para columpio a la torre utilizando cuatro pernos hexagonales de 2 in. (5 cm), arandelas de seguridad y arandelas planas as través del soporte Y16 para viga de columpio y el larguero G4. Apriete de forma segura pero no demasiado.

PASO 10

Instalación de las estacas de metal: Mida 8 in. (20,3 cm) hacia adentro desde el extremo exterior de la tabla a tierra G1 para la ubicación de la estaca. Ahora fije las estacas a la tabla a tierra G1 utilizando el perno Phillips cabeza segmentada de 1 in. (2,5 cm), dos arandelas planas, arandela de seguridad y arandela cilíndrica de acuerdo al diagrama de la derecha. Necesitará un destornillador largo para apalancar. En algunos casos es necesario cavar un agujero para colocar la estaca y cemento.

PASO 11

Coloque los columpios y el trapecio con este procedimiento simple:

- Coloque todas las cadenas en el gancho Carabinero Y5.
- Cuelgue los columpios y el trapecio como se ilustra más abajo.
- Deslice los tubos plásticos de seguridad Y6 en el gancho carabinero.

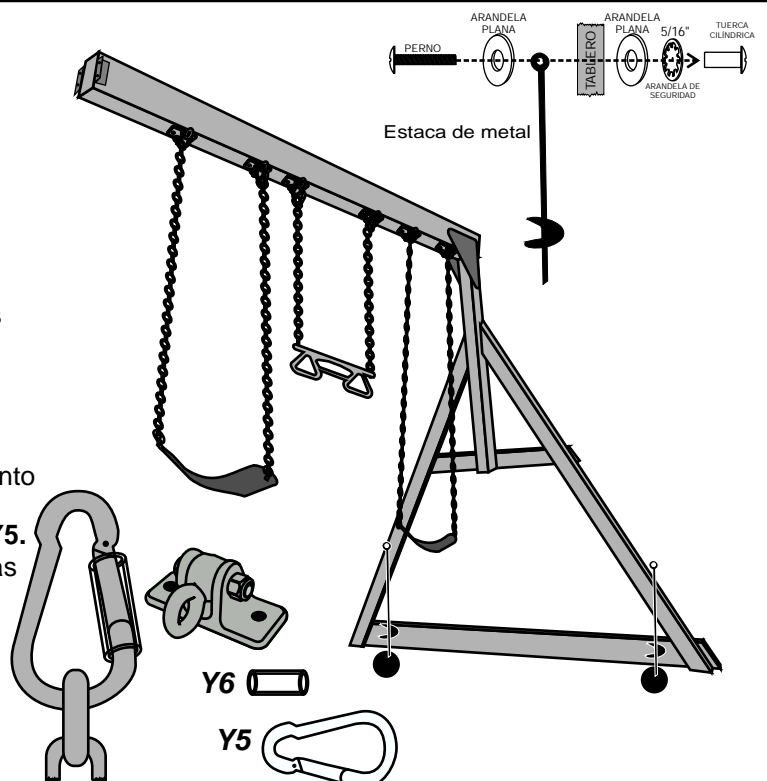

LEISURE TIME PRODUCTS

P.O. Box 459 • Siloam Springs, AR 72761

Part # 5047 Next Generation MONKEY BAR ASSEMBLY INSTRUCTIONS

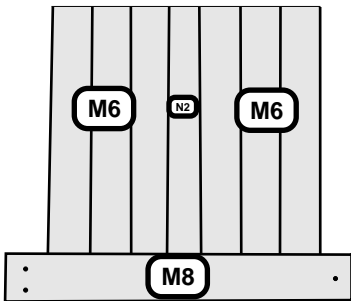

STEP 1

You will need to remove wall to create opening. The Monkey Bar Add-On will attach to a Sculptured Rail G2 which will be a top rail on the back left of your sets Club House. This space is the recommended location. Using a 3/8" drill bit drill thru Sculptured Rail at marks per diagram.

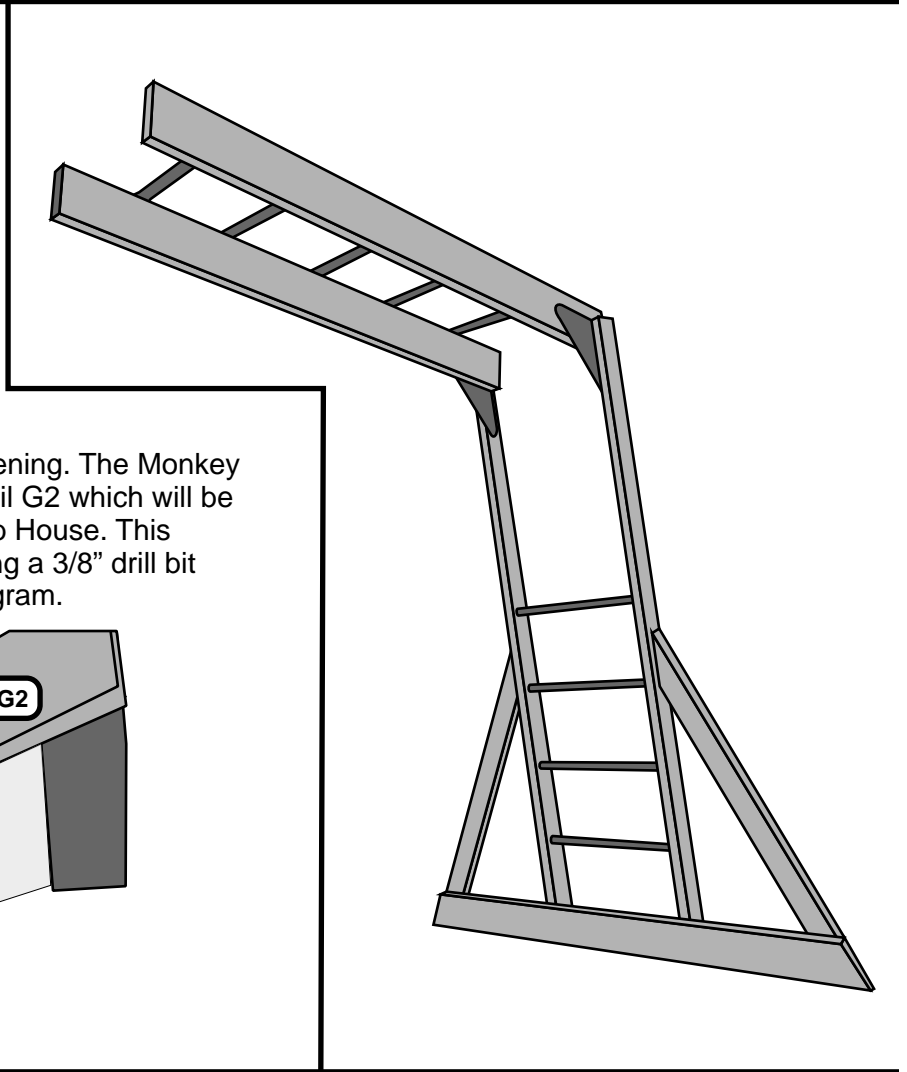
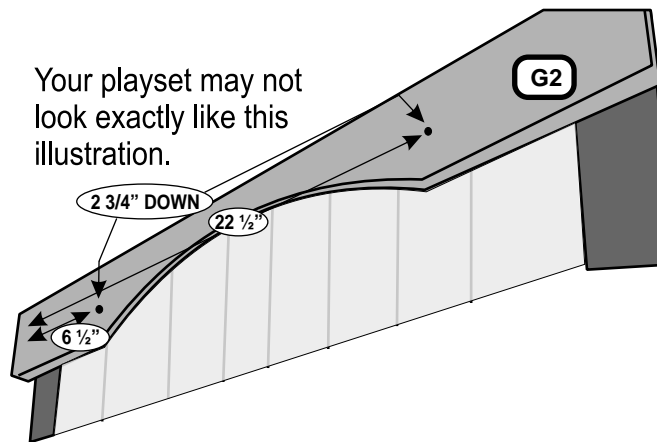

STEP 2

Fasten the five Monkey Bar Ladder Rungs Y14 to the Monkey Bar Rails E2 left rail and E3 right rail using 2 1/2" Joint Connectors, Lock Washers and Flat Washer.

Make sure the Rails are approximately 22 1/2" across the end. Tighten the Joint Connectors just snug.

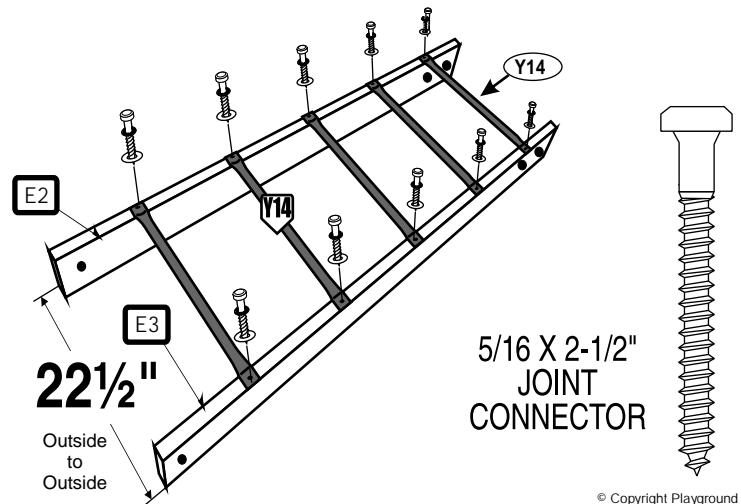

© Copyright Playground Inc

LEISURE TIME PRODUCTS

If you need assistance with parts or have assembly questions, please call Customer Service at 866-362-1123. Our regular office hours are Monday through Friday, 7:00 a.m. to 4:00 p.m. Central Time

STEP 3

Attach the Y40 Bracket to the ends of both Monkey Bar Rails using 2" Hex Head Bolts, Lock Washers, Washers and 5/16" Lock Nut. Tighten securely but do not over tighten.

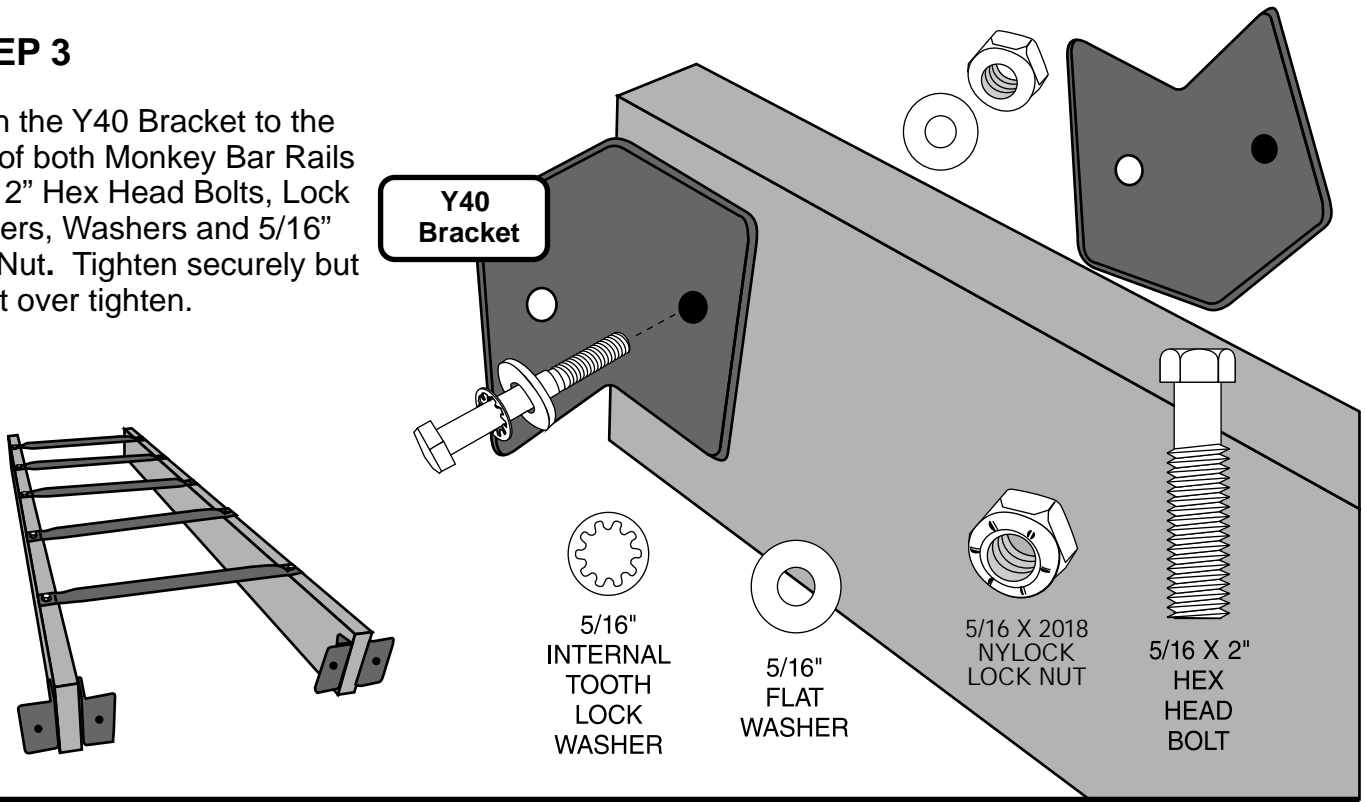

STEP 4

Pound the Metal End Ladder Rungs Y15 into one of the End Ladder Rails E1. Use Spacer Block as a cushion between The Rungs and your hammer.

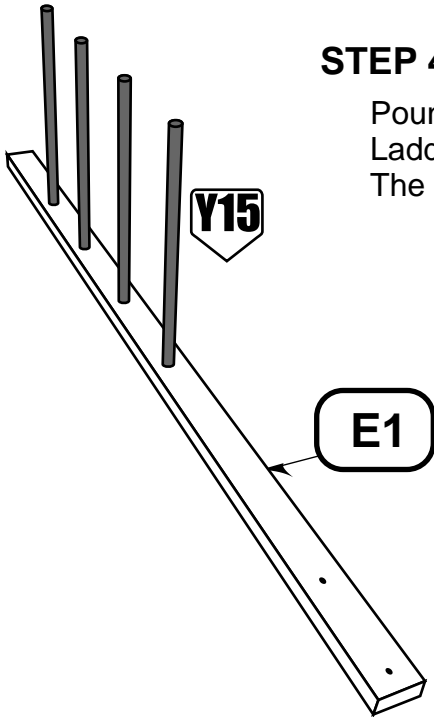

Line up the rungs with the holes in the other End Ladder Rail E1 and pound it down using the Spacer Block to prevent marking the Ladder Rail with the hammer.

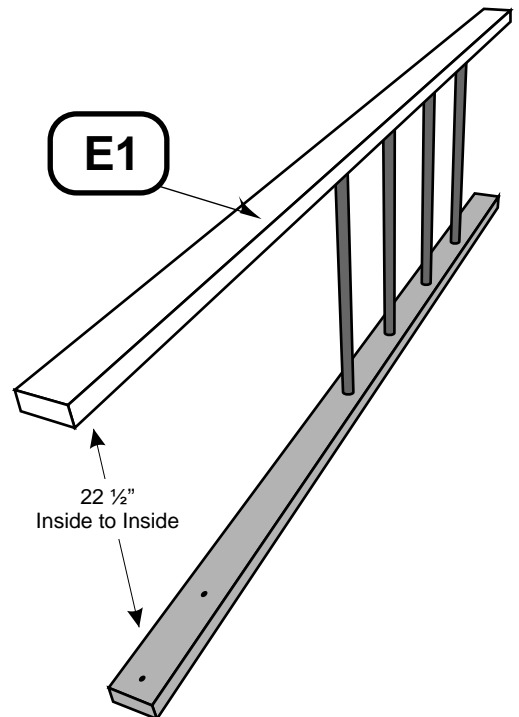

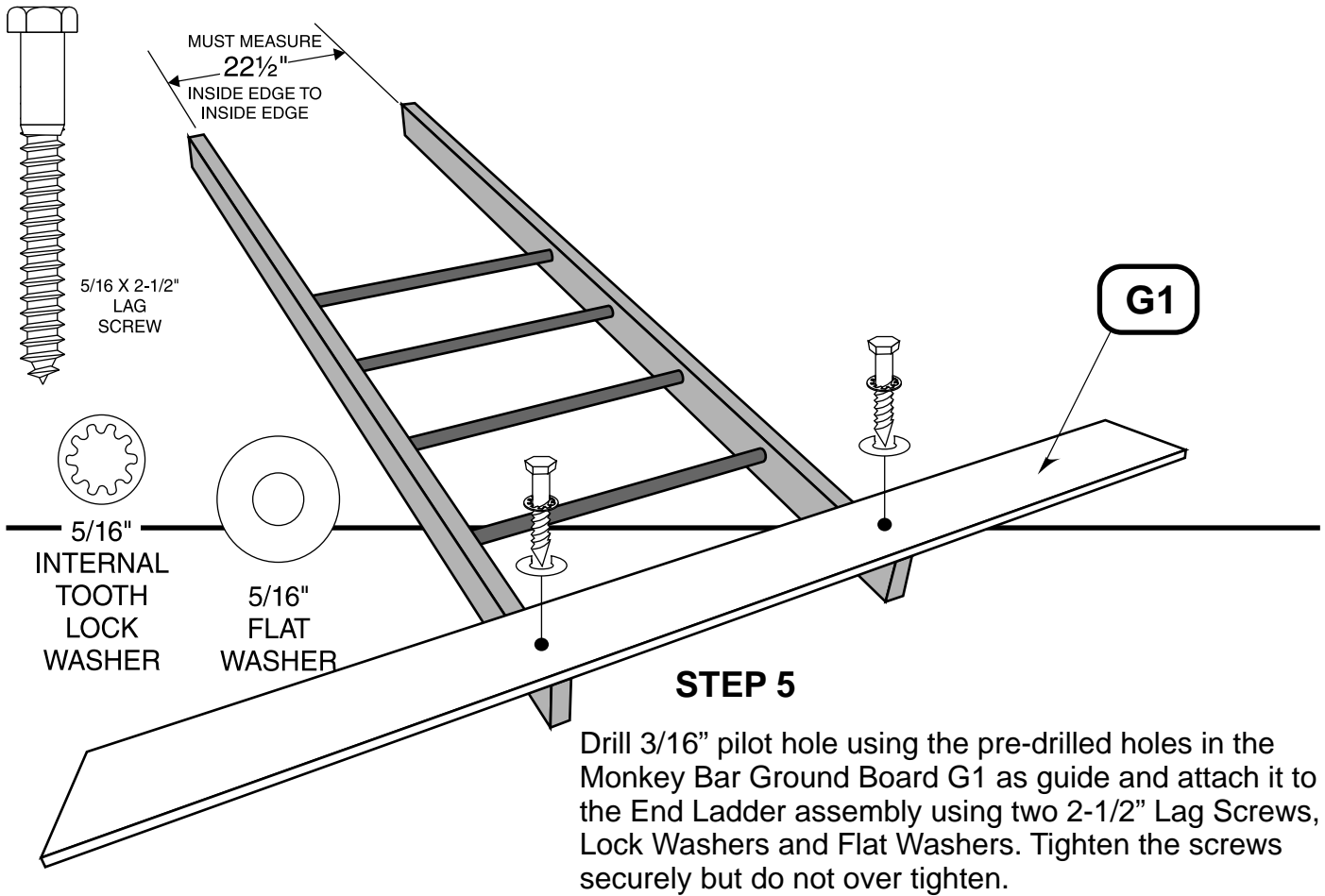

STEP 6

Attach the two Short Angle Braces E4 to the End Ladder Rails E1 with 3-1/4" Hex Bolts, Lock Washers, Flat Washers and Spike Tee Nuts.

Drill 3/16" pilot holes using the pre-drilled holes in the Ground Board as guide and attach it to the Short Angle Braces using 2" Lag Screws, Lock Washers and Flat Washers.

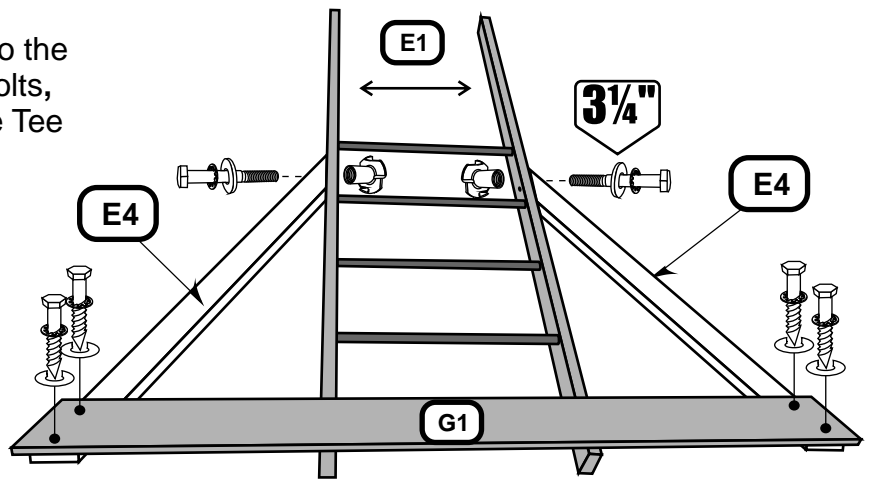

Tighten all bolts and screws securely, but do not over tighten.

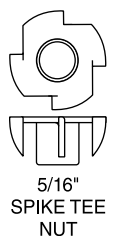
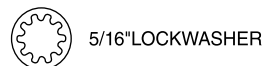
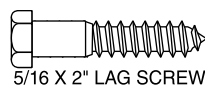

STEP 7

Lay the Monkey Bar assembly and the End Ladder assembly end to end as shown. Then Connect them with 6" Metal Triangle Brace between them as shown with 3" Hex Head Bolts, Lock Washers, Flat Washers and Spike Tee Nuts and 1-1/2" Hex Head Bolts, Lock Washers, Flat Washers and Spike Tee Nuts.

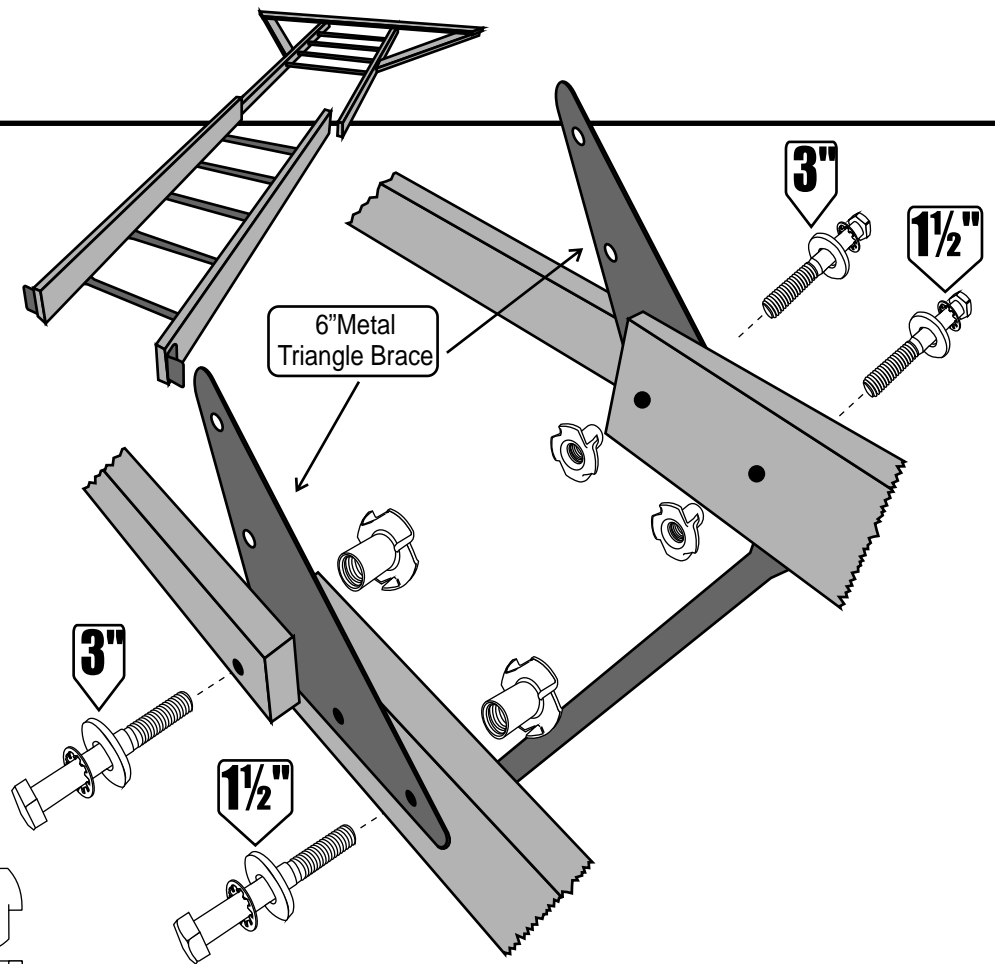
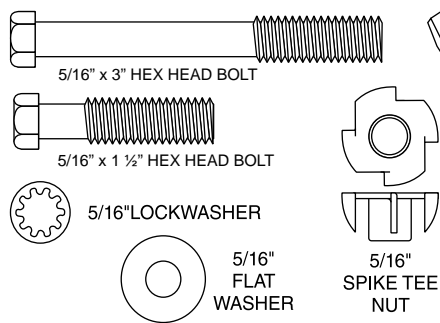

STEP 8

Swing up the End Ladder Assembly and line up the pre-drilled holes in the Ladder Rails with the holes in the green Metal Triangles. Secure with two 1-1/2" Hex Head Bolts, Lock Washers, Flat Washers and Spike Tee Nut. Tighten securely, but do not over tighten.

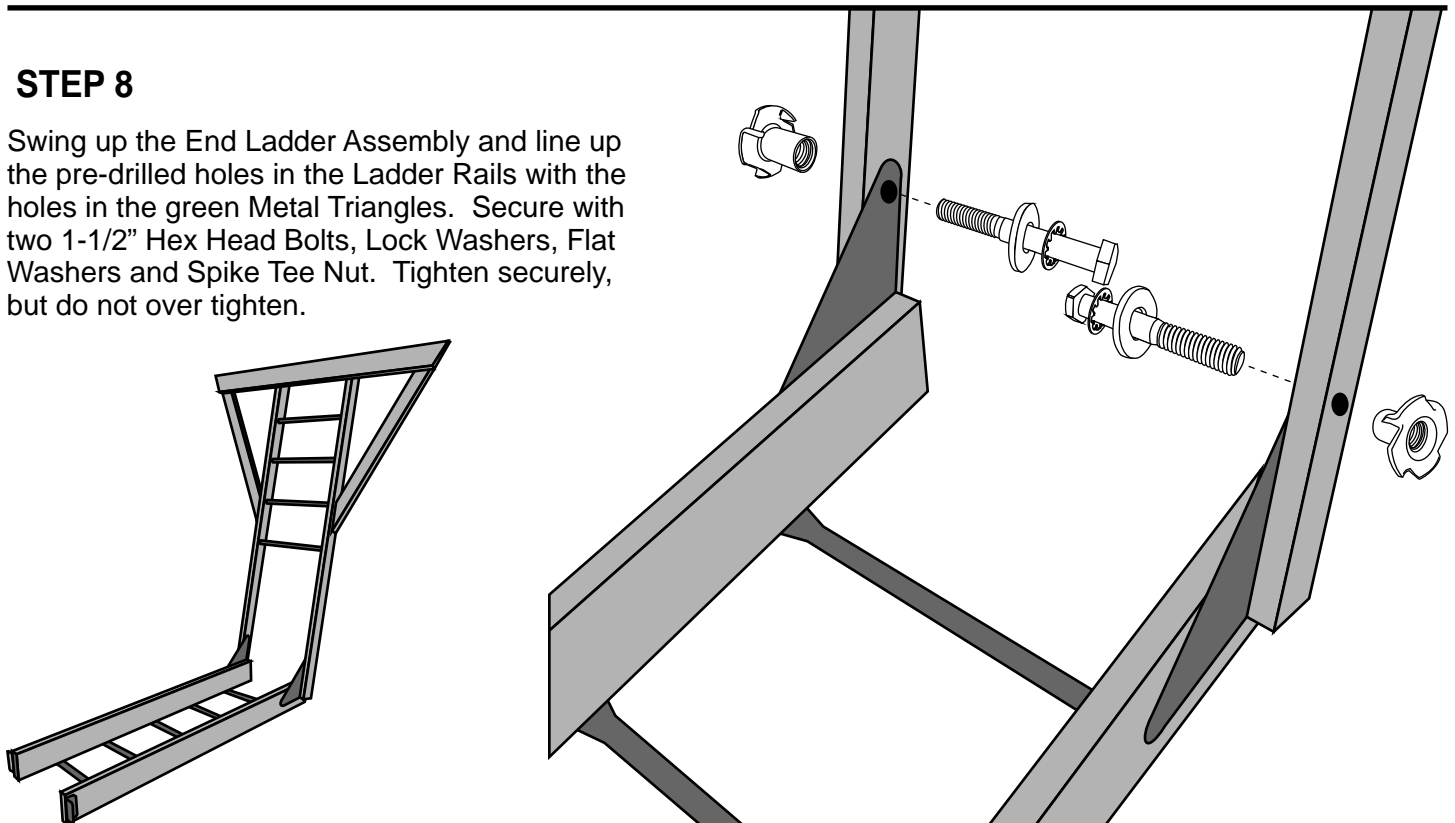

STEP 9

Turn the Monkey Bar assembly over and put into position. Secure the Monkey Bar assembly to Sculptured Rail G2 with 1-1/4" Hex Head Bolts, Lock Washers, Flat Washers and Spike T Nuts according to the bolting diagram shown below. Also 2" Lag Bolt, Lock Washers and Flat Washers.

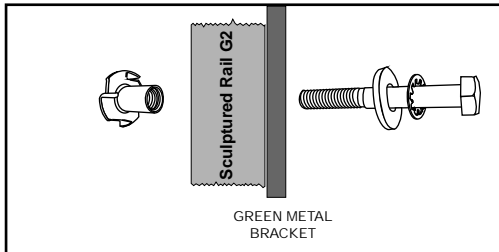
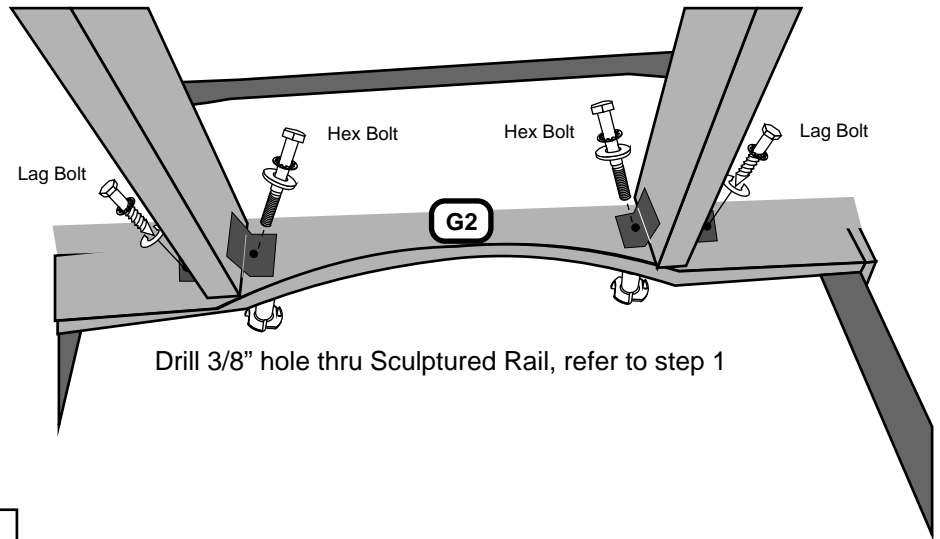

SECURELY TIGHTEN ALL BOLTS AND SCREWS ON THE MONKEY BAR ASSEMBLY AT THIS POINT. DO NOT OVER TIGHTEN.

STEP 10

Metal stake installation: measure in 8" from outside edge of G1 ground board for ground stake location. Then screw stake into ground using a long screw driver for leverage until stake is approximately 1" down from top of ground board. Now using a 3/8" drill bit and hole in stake as guide, drill thru ground board and attach using 1" Phillips Truss Head Bolt, Flat Washers and Lock Washer with Barrel Nut.

In some cases you may need to dig hole attach stake to board then fill with cement keeping below ground level.

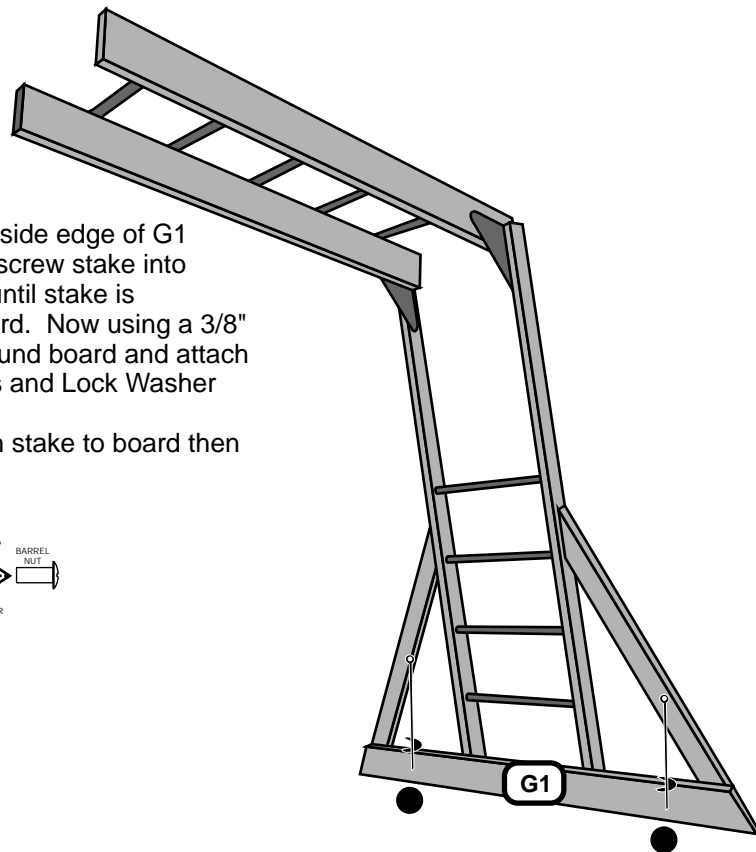
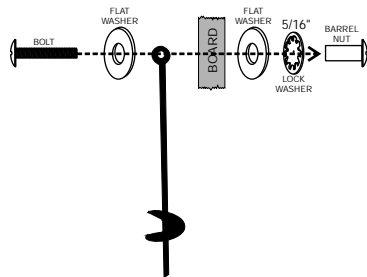

LEISURE TIME PRODUCTS

P.O. Box 459 • Siloam Springs, AR 72761

Parte # 5047

Última Generación

PASAMANOS

INSTRUCCIONES DE ENSAMBLAJE

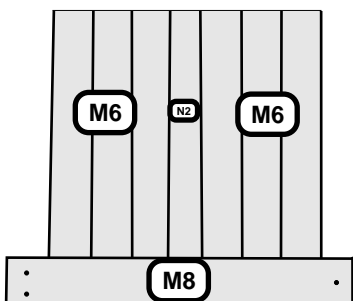

PASO 1

Deberá retirar la pared para crear una abertura. El Pasamanos se fija a un larguero tallado G2 el cual será un larguero superior en la parte posterior izquierda de la casa club. Este espacio es la ubicación que se recomienda. Utilizando una broca para taladro de 3/8 in. (9,5 mm), taladre el larguero tallado en las marcas de acuerdo al diagrama.

La unidad puede que no luzca como esta ilustración.

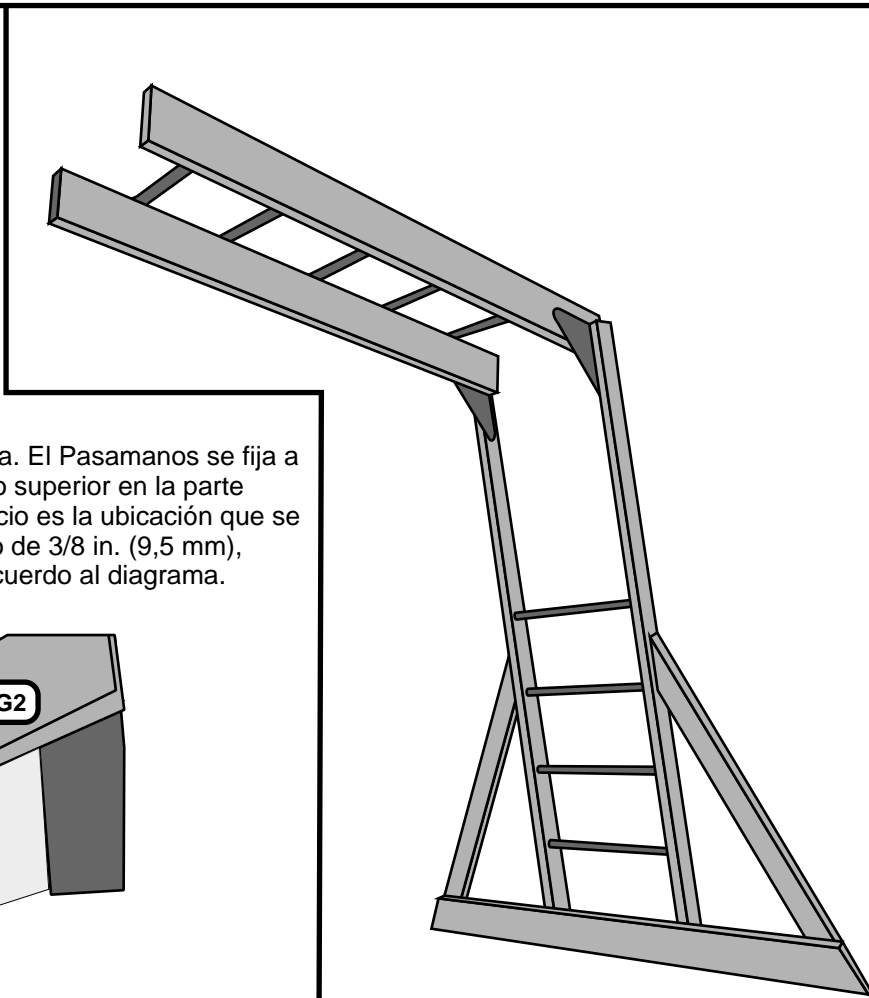
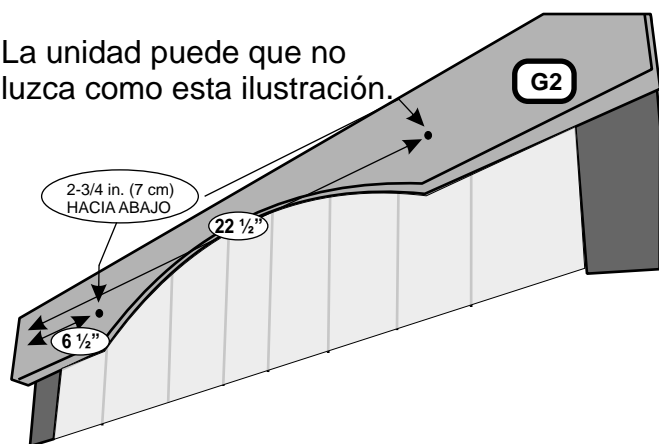

PASO 2

Asegure los cinco peldaños de la escalera para el pasamanos Y14 a los largueros del pasamanos larguero izquierdo E2 y larguero derecho E3 utilizando dos conectores de uniones de 2-1/2 in. (6,3 cm), arandelas de seguridad y arandela plana.

Cerciórese de que la distancia entre los largueros sea 22-1/2 in. (57,2 cm). Apriete los conectores de juntas, pero no demasiado.

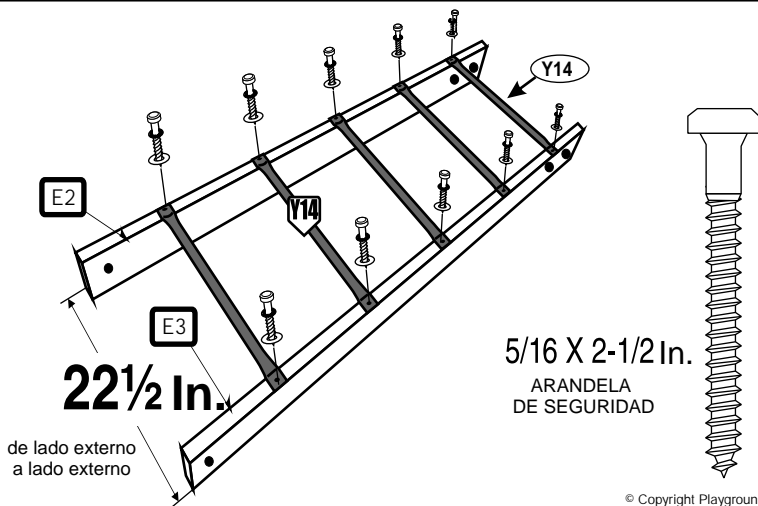

© Copyright Playground Inc

PRODUCTOS LEISURE TIME

Si necesita ayuda con las partes o tiene preguntas sobre el ensamblaje, por favor llame al Dpto. de Servicio al Cliente al 866-362-1123. Nuestras horas regulares de oficina son de lunes a viernes, de 7:00 a.m. a 4:00 p.m. Hora Central.

PASO 3

Fije los soportes Y40 a los extremos de ambos largueros para el pasamanos utilizando pernos cabeza hexagonal de 2 in. (5,1 cm), arandelas de seguridad, arandelas y la tuerca de seguridad de 5/16 in. (8 mm). Apriete de forma segura pero no demasiado.

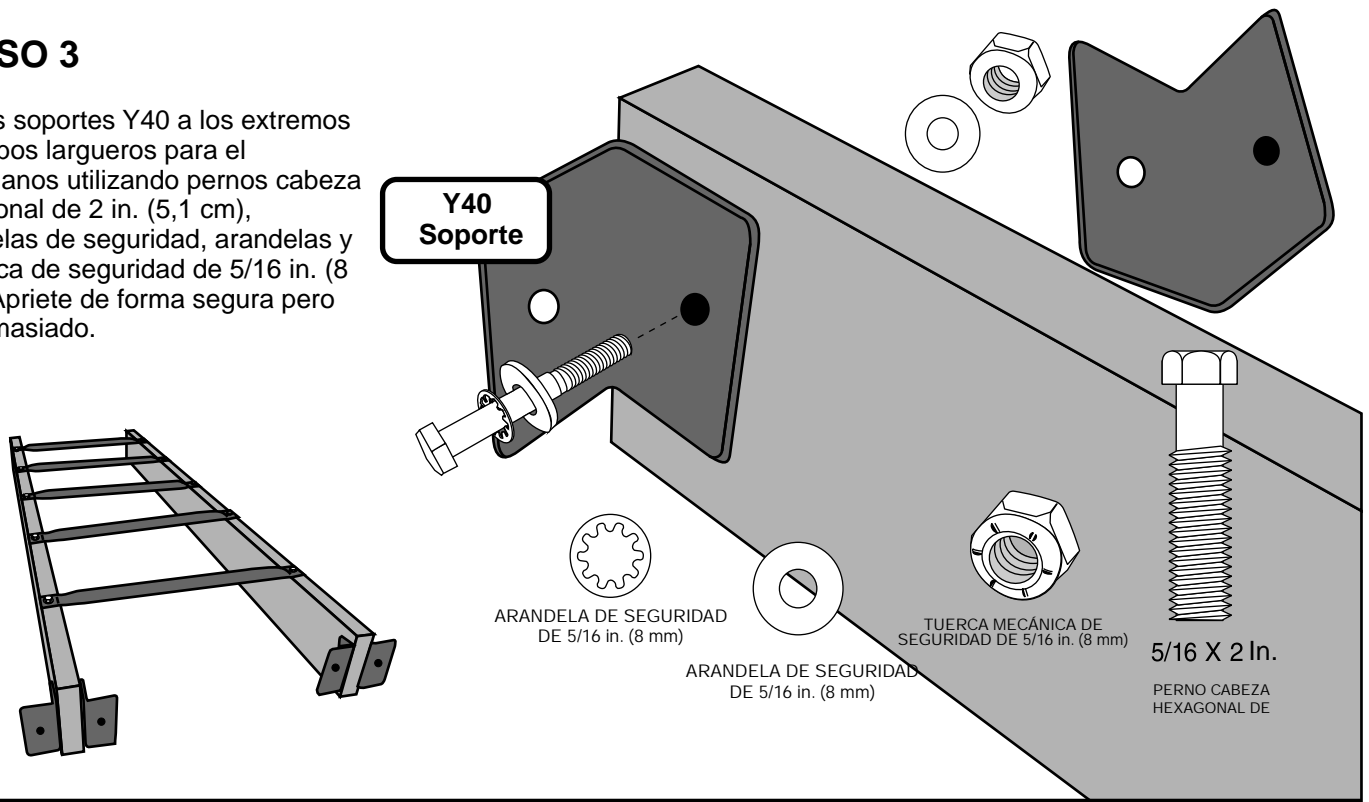

PASO 4

Martille los peldaños de metal de la escalera terminal Y15 en uno de los largueros E1 de la escalera terminal. Use un bloque espaciador como amortiguador entre los peldaños y el martillo.

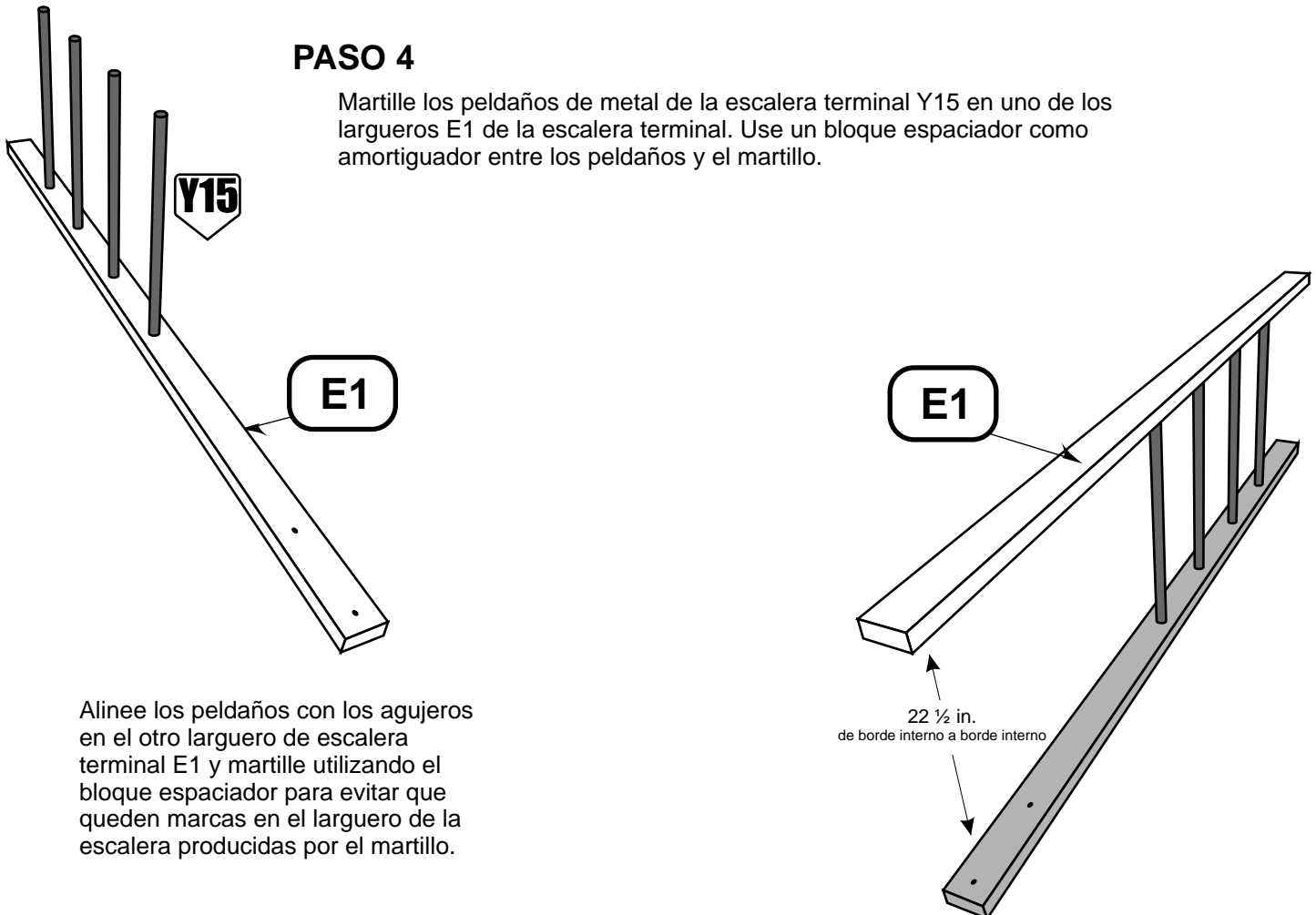

Alinee los peldaños con los agujeros en el otro larguero de escalera terminal E1 y martille utilizando el bloque espaciador para evitar que queden marcas en el larguero de la escalera producidas por el martillo.

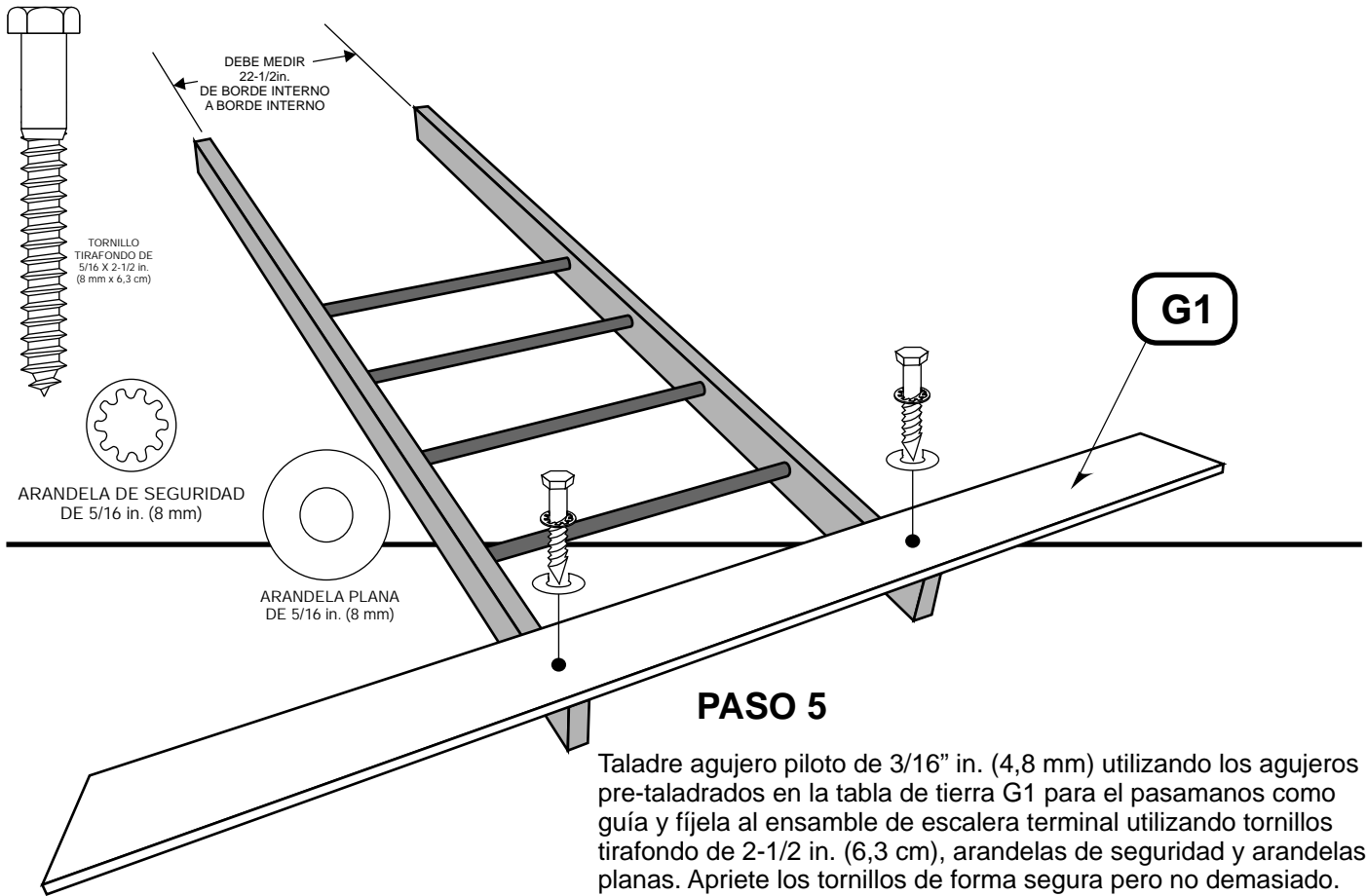

PASO 6

Fije los dos refuerzos de ángulo corto E4 a los largueros de escalera terminal E1 con pernos hexagonales de 3-1/4 in. (8,3 cm), arandelas de seguridad, arandelas planas y tuercas en T con espigas.

Taladre agujeros piloto de 3/16 in. (4,8 mm) utilizando los agujeros pre-taladrados en la tabla de tierra como guía y fíjela a los soportes cortos en ángulo utilizando tornillos tirafondo de 2 in. (5,1 cm), arandelas de seguridad y arandelas planas.

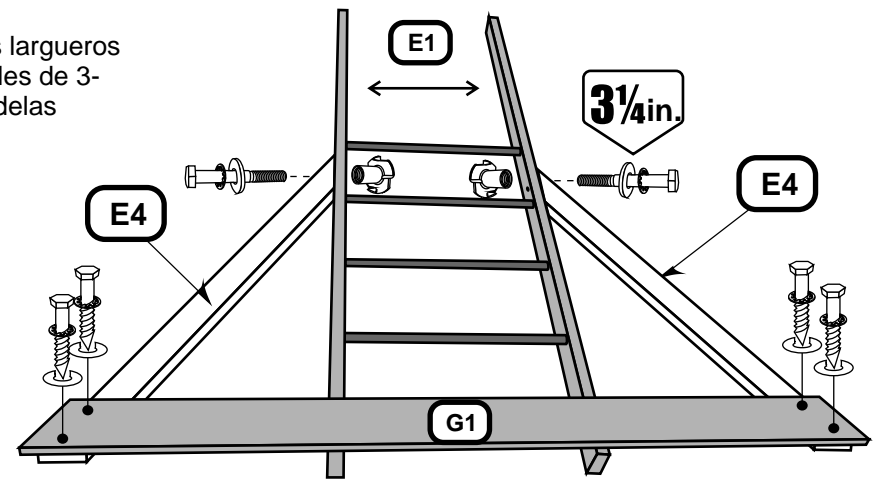

Apriete los tornillos de forma segura pero no demasiado.

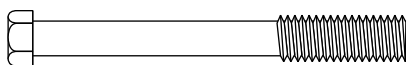

PERNO CABEZA HEXAGONAL DE 5/16 X 3-1/4 in. (8 mm x 3,8 cm)

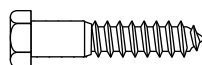

TORNILLO TIRAFONDO DE 5/16 X 2- in. (8 mm x 5,1 cm)



ARANDELA DE SEGURIDAD DE 5/16 in. (8 mm) CON DIENTES INTERNOS



ARANDELA PLANA DE 5/16 in. (8 mm)

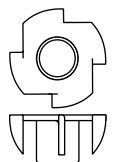

TUERCA EN T DE 5/16 in. (8 mm) CON ESPIGA

PASO 7

Coloque el ensamble del pasamanos y el ensamble de la escalera terminal hacia el extremo como se ilustra. Luego conéctelos con la abrazadera triangular de metal de 15,2 cm entre ellos como se ilustra con pernos cabeza hexagonal de 7,6 cm, arandelas de seguridad, arandelas planas y tuercas en T con espigas y pernos hexagonales de 3,8 cm, arandelas de seguridad, arandelas planas y tuercas en T con espigas.

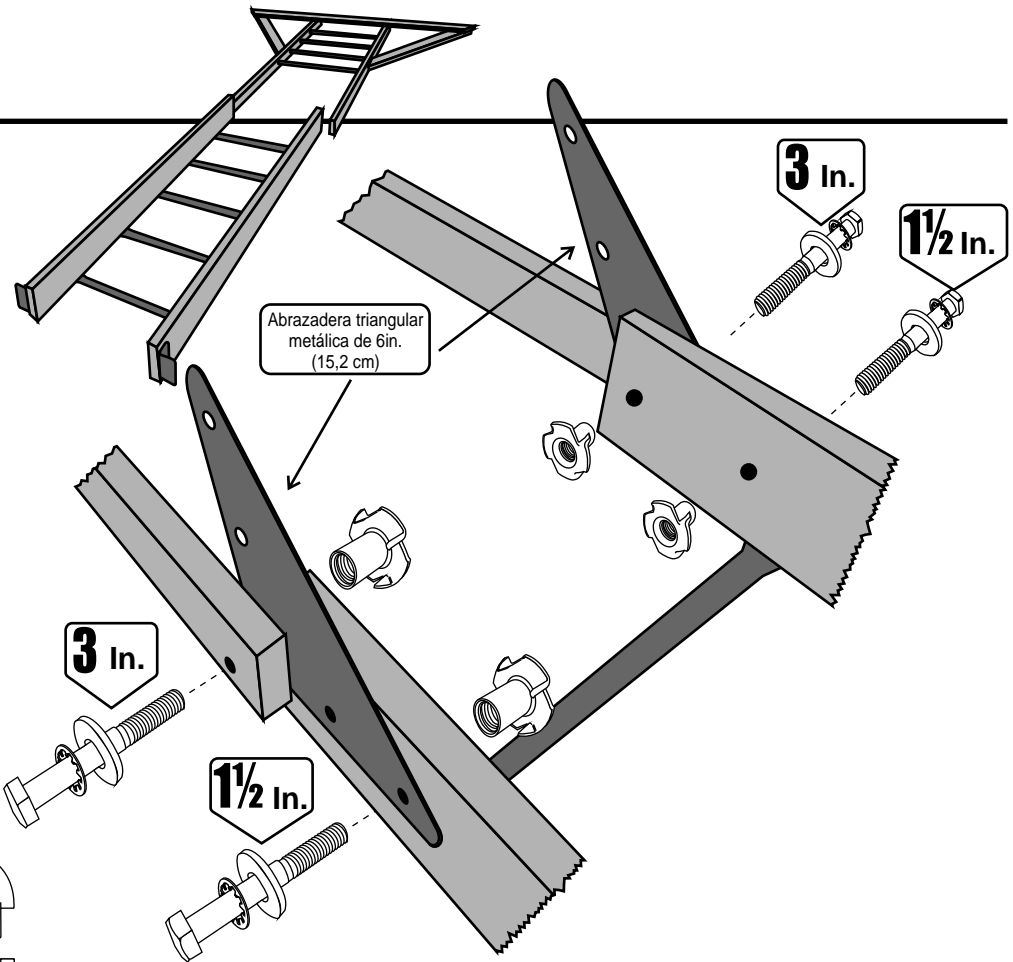
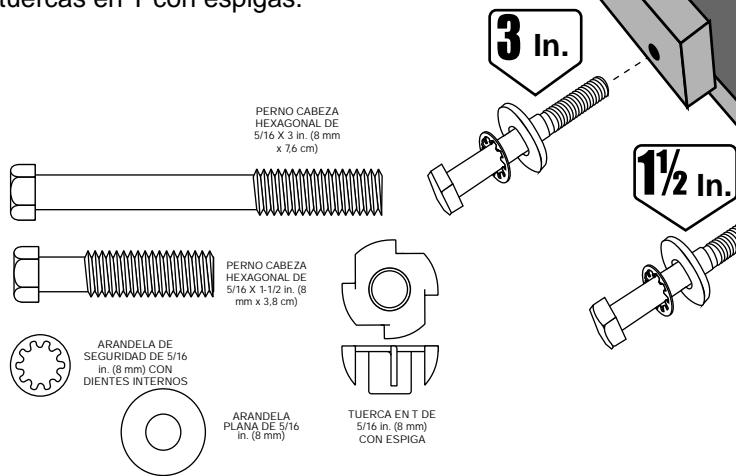

PASO 8

Gire el ensamble de escalera terminal y alinéelo con los agujeros pre-taladrados en los largueros de la escalera con los agujeros en los triángulos verdes metálicos. Asegure con dos pernos cabeza hexagonal de 1-1/2 in. (3,8 cm), arandelas de seguridad, arandelas planas y tuerca en T con espigas. Apriete de forma segura pero no demasiado.

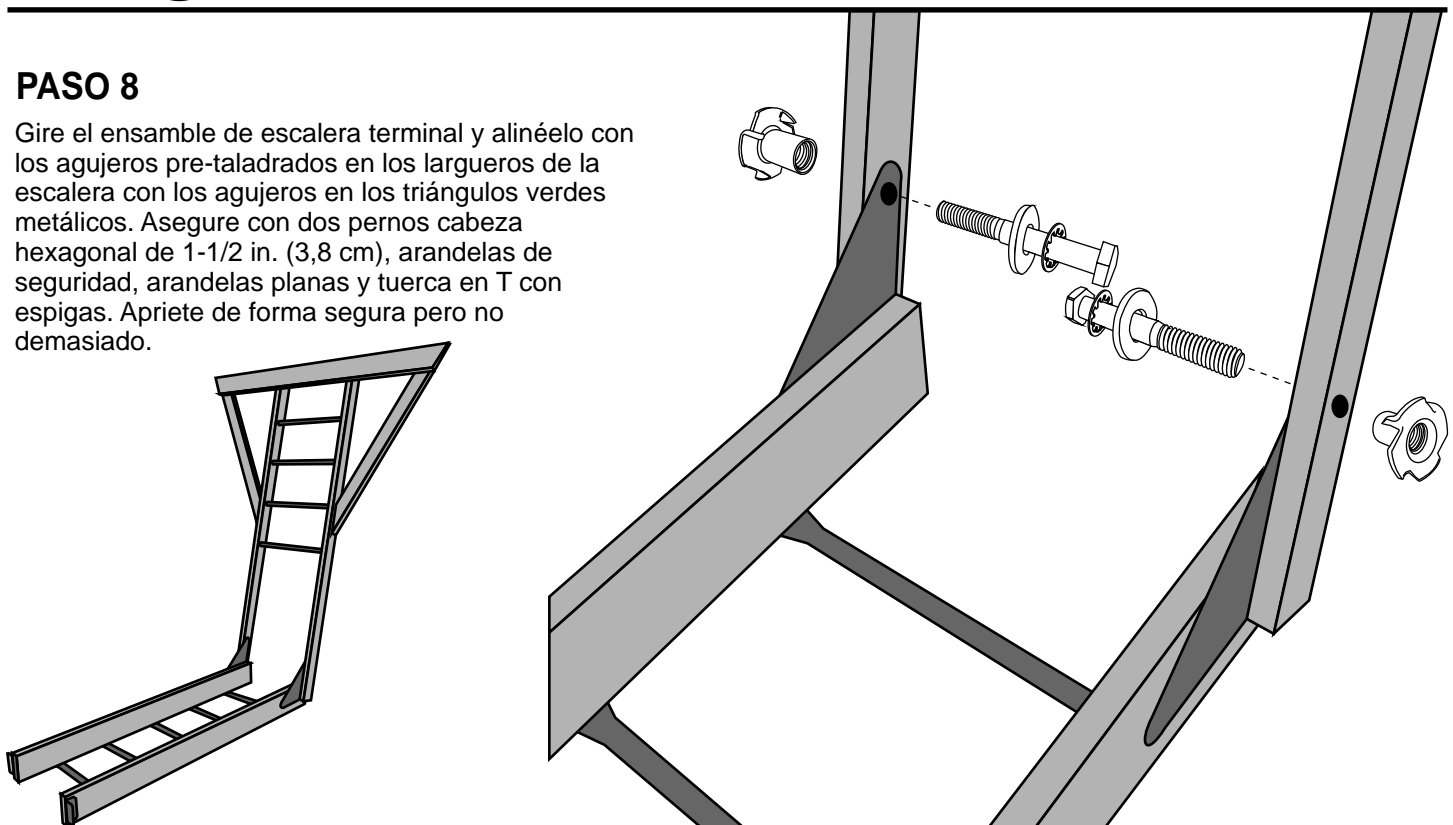

PASO 9

Déle vuelta al ensamble del pasamanos y colóquelo en posición. Asegure el ensamble del pasamano al larguero tallado G2 con pernos cabeza hexagonal de 3,2 cm, arandelas de seguridad, arandelas planas y tuerca en T con espigas de acuerdo al diagrama que se ilustra más abajo. También pernos tirafondo de 2 in. (5,1 cm), arandelas de seguridad, arandelas planas.

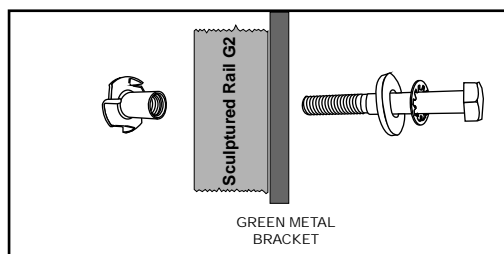
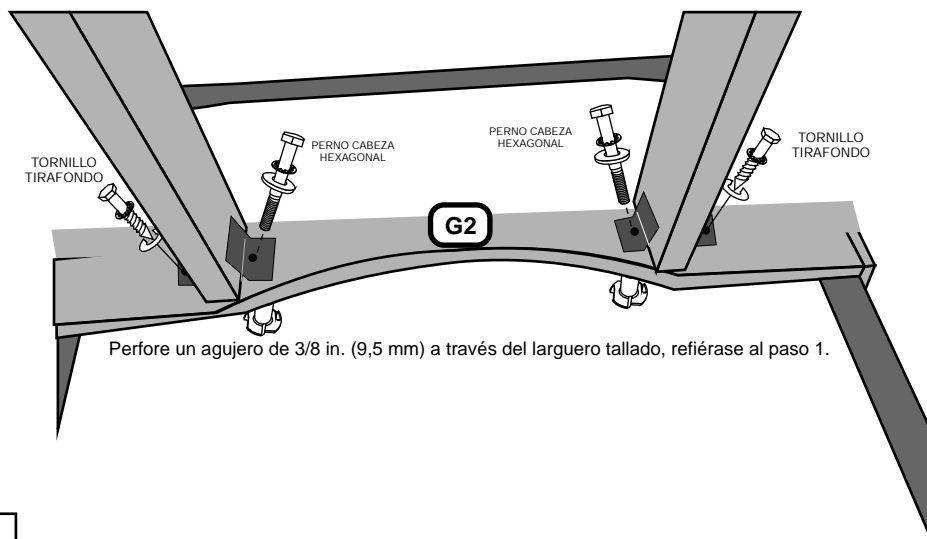

EN ESTE PUNTO APRIETE TODOS LOS PERNOS Y TORNILLOS DE FORMA SEGURA EN EL ENSAMBLE DEL PASAMANOS. NO APRIETE DEMASIADO.

PASO 10

Instalación de las estacas de metal: Mida 8 in. (20 cm) hacia adentro desde el extremo exterior de la tabla a tierra G1 para la ubicación de la estaca. Luego atornille la estaca en la tierra utilizando un destornillador largo para apalancar hasta que la estaca esté aproximadamente 1 in. (2,5 cm) hacia abajo con respecto a la parte superior de la tabla a tierra. Ahora utilizando una broca de taladro de 3/8 in. (9,5 mm) y el agujero en la estaca como guía, taladre a través de la tabla a tierra y fije utilizando un perno Phillips cabeza segmentada de 1 in. (2,5 cm), arandelas planas y arandelas de seguridad con tuerca cilíndrica.

En algunos casos será necesario cavar un agujero, fijar la estaca a la tabla y luego llenar con cemento manteniéndolo por debajo del nivel del suelo.

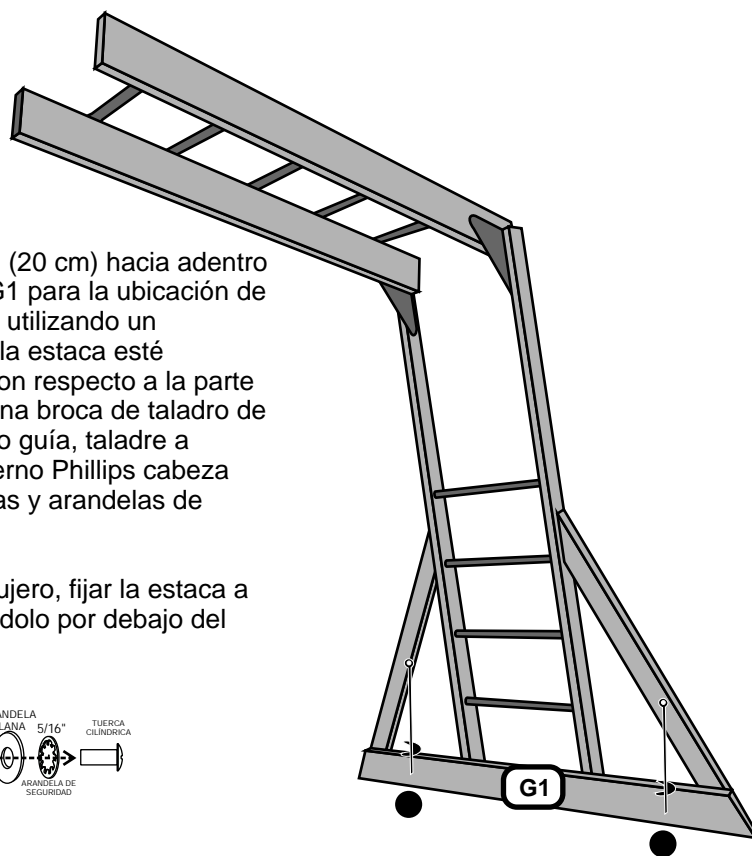
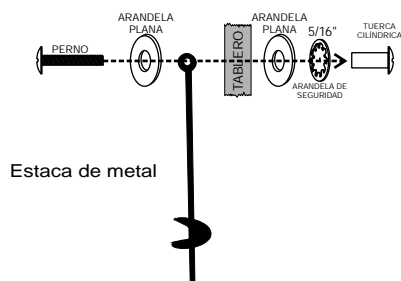

LEISURE TIME PRODUCTS

P.O. Box 459 • Siloam Springs, AR 72761

Part # 5067

Next Generation

PICNIC TABLE ASSEMBLY INSTRUCTIONS

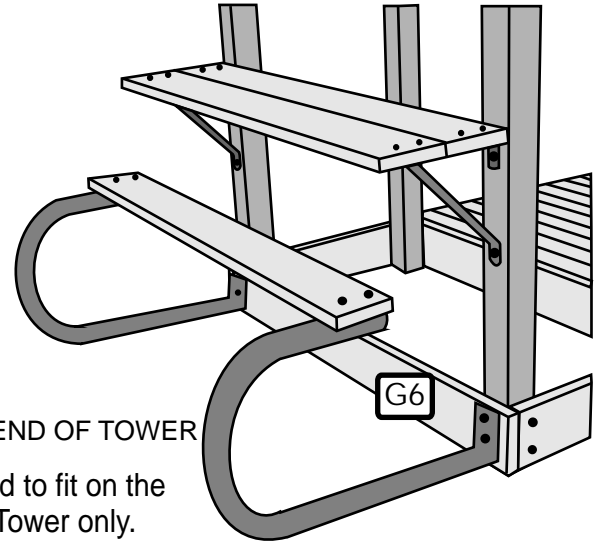

RIGHT END OF TOWER

NOTE: This kit is designed to fit on the Right End of the Tower only.

Step 1

Begin by removing the lag Screws from base board G6 and placing a **Picnic Seat Support** against it. The existing holes in G6 will align with the holes in the Seat Support.

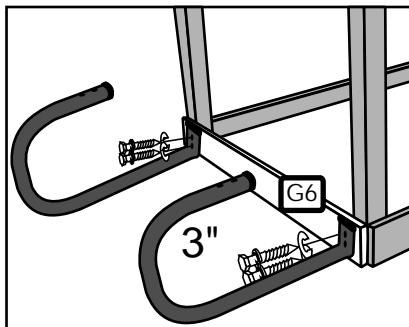
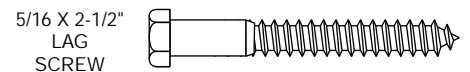
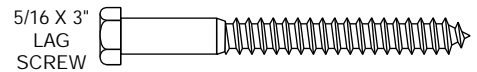

Step 2

Place black rectangle caps on seat support brackets and attach the Seat Support using a 3" lag Screw, Lock Washer and Flat Washer through the existing holes.

Repeat this procedure for the second Seat Support on the other side of tower.

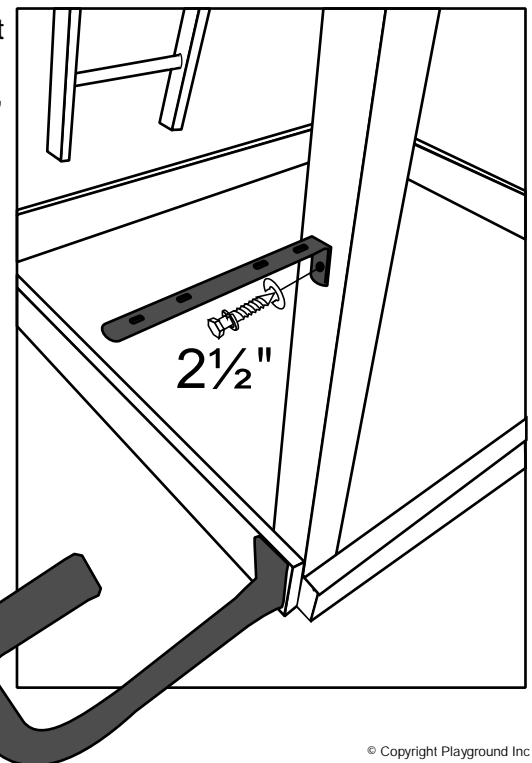

Step 3

Measuring 25" from the ground, mark the Leg and drill a 3/16" pilot hole in the center of the C3 post. Then secure a Metal Picnic Table Support to the Leg with a 2 1/2" Lag Screw, Lock Washer and Flat Washer.

Repeat this step on the opposite side of the tower assembly, again measuring 25" up from the ground and drilling a 3/16" pilot hole before attaching the final Metal Picnic Table Support to the Leg with a 2 1/2" Lag Screw, Lock Washer and Flat Washer. Tighten the screws securely, but do not over-tighten.

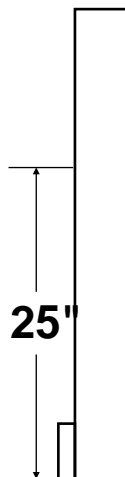

LEISURE TIME PRODUCTS

If you need assistance with parts or have assembly questions, please call Customer Service at 866-362-1123. Our regular office hours are Monday through Friday, 7:00 a.m. to 4:00 p.m. Central Time

© Copyright Playground Inc

Step 4

Attach the first 4-hole Picnic Table board 1x6x45" G1 with four 1/4" x 1" Phillips Head Truss Bolts, Lock Washers and Barrel Nuts.

Leave screws loose until next Step.

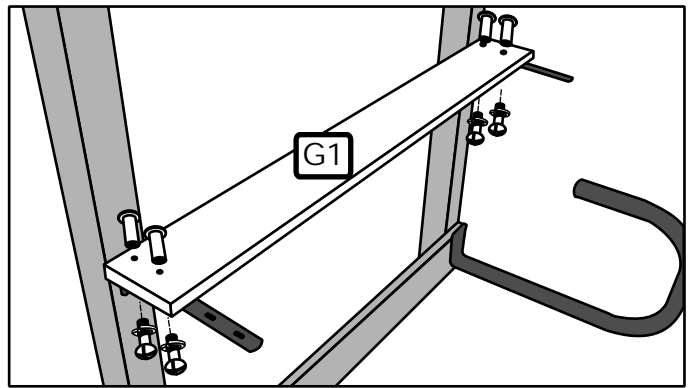
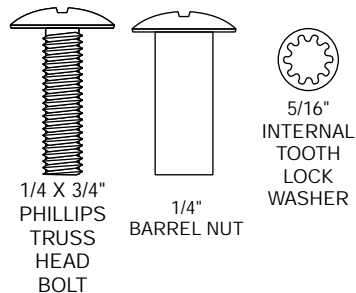

Step 5

The last 4-hole Picnic Table board 1x6x45 is assembled with the **Picnic Table Angle Brace** as shown.

Note that the front Screws and Barrel Nuts connect the Metal Angle Brace directly to the Picnic Table Supports installed in the Previous step. Leave screws loose.

Using your carpenter's level, hold the Picnic Table Angle Brace against the Leg, level the table, and use the hole in it as a guide to drill a 3/16" pilot hole. Then attach the bottom of the Picnic Table Angle Brace to the Leg with a 2 1/2" Lag Screw, Lock Washer and Flat Washer.

Repeat this Step on both ends of the Picnic Table Board using four 1/4"x1" Philips Head Truss Bolts, Lock Washers and Barrel Nuts.

Tighten all bolts securely, but do not over-tighten.

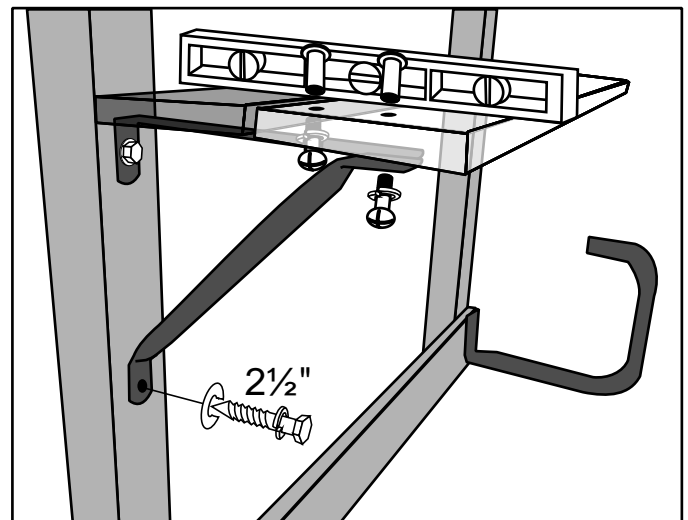

Step 6

Put Round Plastic Caps on seat supports and attach Picnic Table Seat 2x6x45" G2 using four 1/4" x 2 1/4" Phillips Head Truss Bolts, Lock Washers and Barrel Nuts as shown.

Tighten the screws securely, but don't over-tighten.

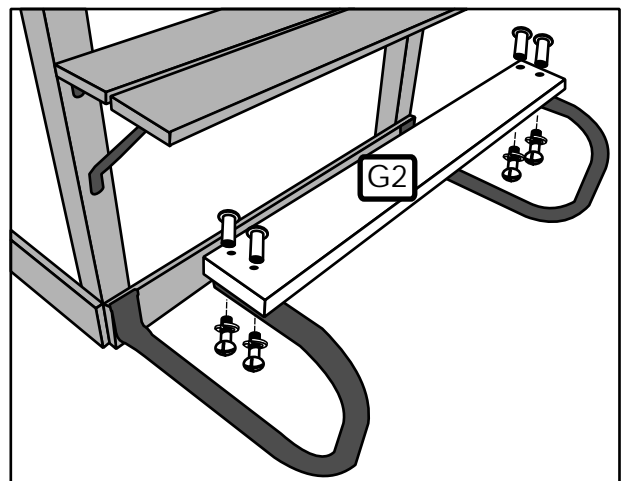

LEISURE TIME PRODUCTS

P.O. Box 459 • Siloam Springs, AR 72761

Parte # 5067

Última Generación

MESA PARA PICNIC

INSTRUCCIONES PARA EL ENSAMBLAJE



EXTREMO DERECHO DE LA TORRE

NOTA: Este kit está diseñado para adaptarse al extremo derecho de la torre solamente.

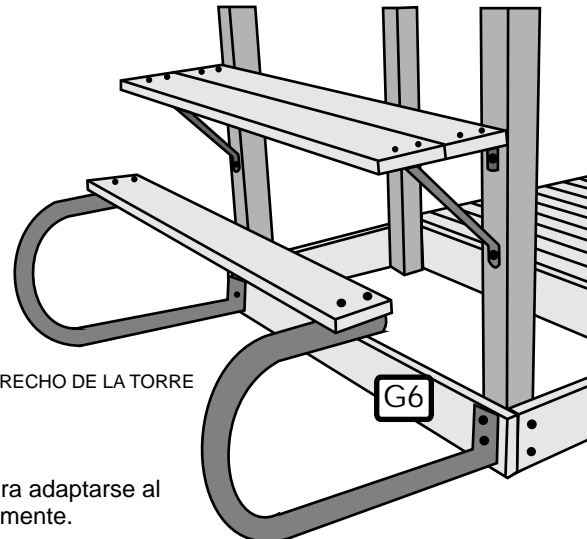

Paso 1

Comience retirando los tornillos tirafondo de la tabla de base G6 y colocando un soporte para el asiento de la mesa para comida al aire libre contra ella. Los agujeros que se encuentran en G6 se alinearán con los del soporte para el asiento.

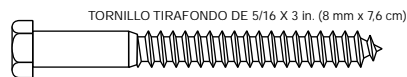

TORNILLO TIRAFONDO DE 5/16 X 3 in. (8 mm x 7,6 cm)



TORNILLO TIRAFONDO DE 5/16 X 2-1/2 in. (8 mm x 6,3 cm)

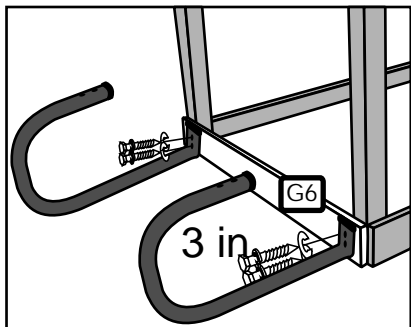

Paso 2

Fije el soporte del asiento utilizando un tornillo tirafondo de 3 in. (7,6 cm), arandela de seguridad y una arandela plana a través de los agujeros pre-existentes.

Repita este procedimiento para el segundo soporte de asiento en el otro lado de la torre.

Step 3

Midiendo 25 in. (63,5 cm) desde el suelo, marque el apoyo y taladre un agujero piloto de 3/16 in. (4,8 mm) en el centro del poste C3. Luego asegure el soporte de metal de la mesa para picnic al apoyo con un tornillo tirafondo de 2-1/2 in. (6,3 cm), una arandela de seguridad y otra arandela.

Repita este paso en el lado opuesto del ensamble de la torre, midiendo de nuevo 25 in. (63,5 cm) hacia arriba desde la tierra y taladrando un agujero piloto de 3/16 in. (4,8 mm) antes de fijar el soporte de metal de la mesa a la pata con un tornillo tirafondo de 2-1/2 in. (6,3 cm), una arandela de seguridad y otra arandela. Apriete los tornillos de forma segura pero no demasiado.

25 in.

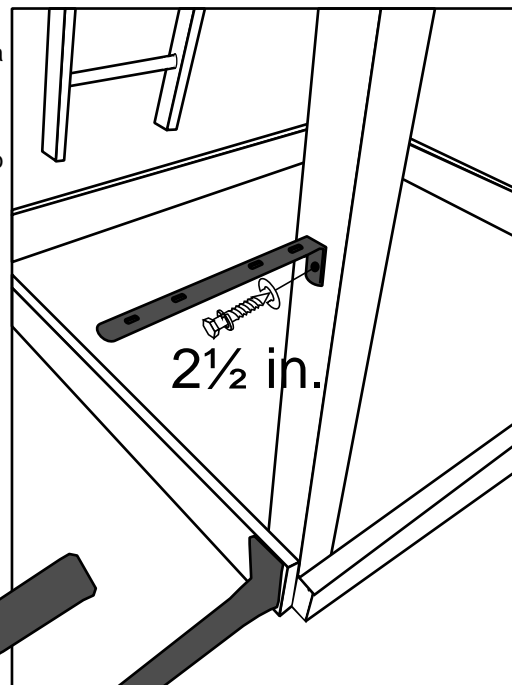

2 1/2 in.

© Copyright Playground Inc

PRODUCTOS LEISURE TIME

Si necesita ayuda con las partes o tiene preguntas sobre el ensamblaje, por favor llame al Dpto. de Servicio al Cliente al 866-362-1123. Nuestras horas regulares de oficina son de lunes a viernes, de 7:00 a.m. a 4:00 p.m. Hora Central.

Paso 4

Fije la primera tabla de la mesa de 1x6x45 in. (2,5 x 15,2 x 114,3 cm) que tiene 4 agujeros con cuatro pernos cabeza de segmentada, arandelas de seguridad y tuercas cilíndricas.

Deje flojos los tornillos hasta el próximo paso.

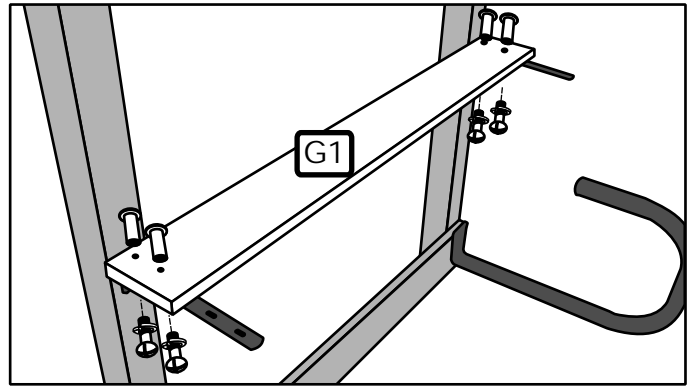
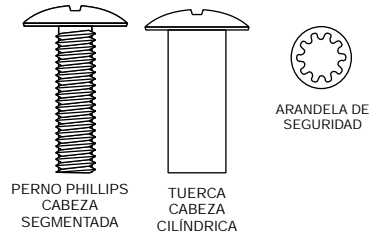

Paso 5

Las última tabla de la mesa de 1x6x45 in. (2,5 x 15,2 x 114,3 cm) con 4 agujeros está ensamblada con el refuerzo metálico en ángulo para la mesa como se ilustra.

Observe que los tornillos del frente y las tuercas cilíndricas conectan el refuerzo metálico en ángulo directamente a los soportes de la mesa que se instalaron en el paso anterior. Deje los tornillos flojos.

Utilizando el nivel de carpintero, sostenga la abrazadera en ángulo para la mesa contra la pata, nivele la mesa y utilice el agujero como guía para taladrar un agujero piloto de 3/16 in. (4,8 mm). Luego fije la parte inferior del refuerzo en ángulo de la mesa a la pata con un tornillo tirafondo de 2-1/2 in. (6,3 cm), una arandela de seguridad y otra arandela.

Repita este paso en ambos extremos de la tabla para mesa, utilizando cuatro pernos Phillips cabeza segmentada de 1/4 x 1 in. (6,3 mm x 2,5 cm), arandela de seguridad y tuerca cilíndrica

Apriete los tornillos de forma segura pero no demasiado.

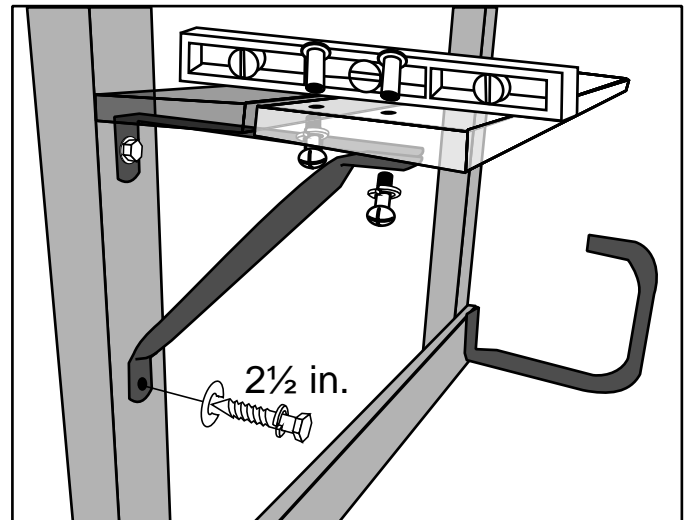

Paso 6

El último asiento G2 para la mesa de 2x6x45 in. (5,1 x 15,2 x 114,3 cm) se coloca utilizando cuatro pernos Phillips cabeza segmentada de 1/4 x 2 1/4 in. (6,3 mm x 5,7 cm), arandela de seguridad y tuerca cilíndrica.

Apriete los tornillos de forma segura pero no demasiado.

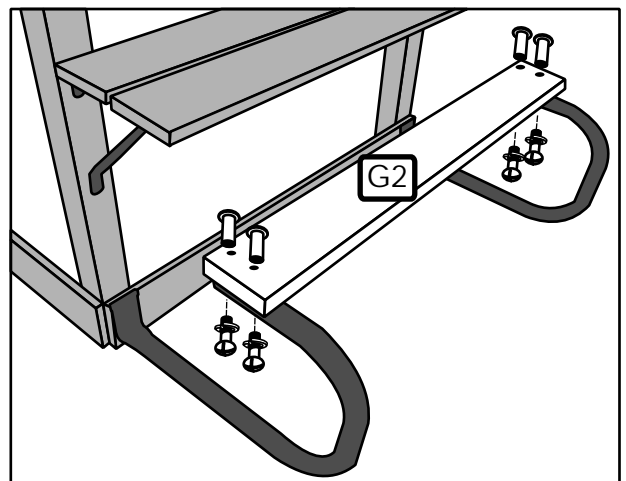

LEISURE TIME PRODUCTS

P.O. Box 459 • Siloam Springs, AR 72761

Part # 5027

Next Generation

TUNNEL

ASSEMBLY INSTRUCTIONS

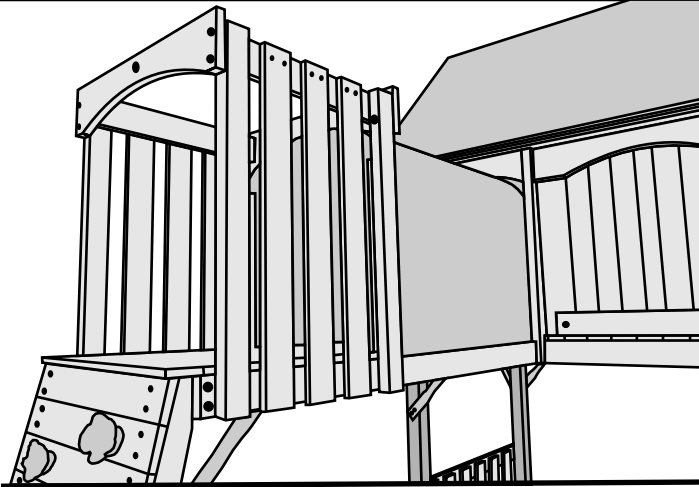

Attention this Tunnel Kit requires 1 Rock Wall Kit for attachment. (The following 2 steps shows Rock Wall construction). Unroll Plastic Tunnel and weigh down so it will flatten out.

STEP 1

Lay the Rock Wall Rails E1 on ground and then attach 1 Rock Wall slat M3 1/8" from top of rails. Wall slat will overhang approximately 1 5/16" over rail. E1 Rock Wall Rails should be approximately 19 1/2" outside to outside. Attach using 2" wood screws and attach bottom rail slat M2 approximately 1/8" from bottom of rail.

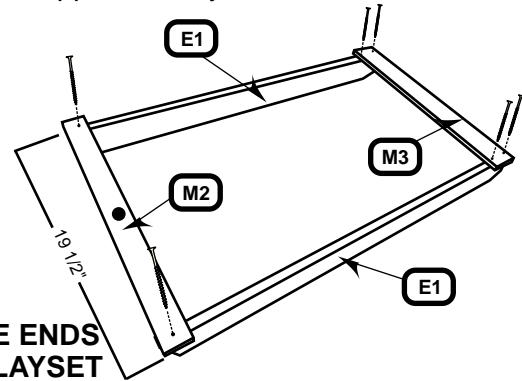
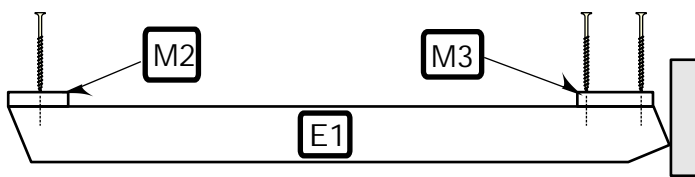

TIP: TO HELP KEEP THE ROCK WALL SQUARE, PUSH THE ENDS OF THE RAILS AGAINST THE GROUND BOARD OF THE PLAYSET

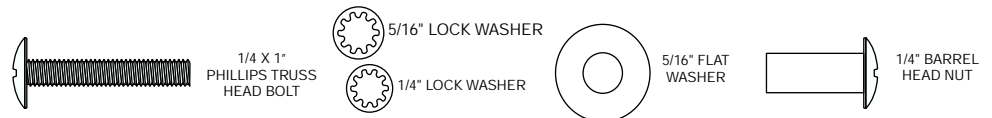
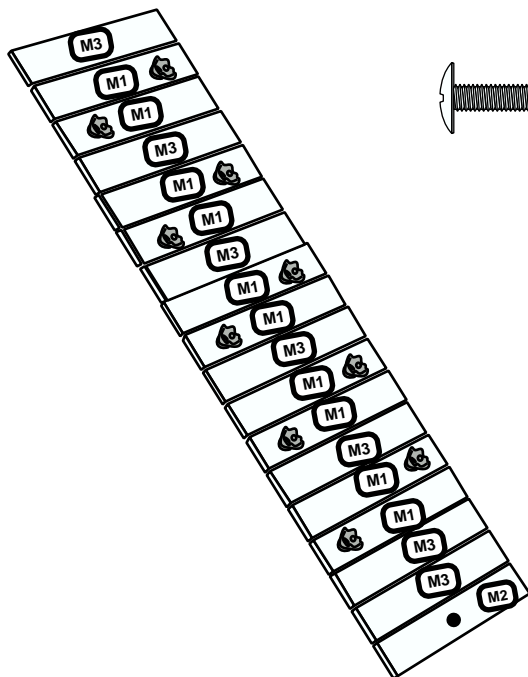

STEP 2

Attach all the **Green Plastic Rocks** to the **Rock Wall Boards M1** using **1/4x1"** Phillips Truss Head Bolts thru the rock then the slat and 5/16" Flat Washer, 5/16 ITLW Washer and Barrel Nuts. Alternate slats M1 like diagram noticing every third slat is a M3 with no rocks on them (no rocks on the last 3 slats Tighten securely but don't over tighten. Too much pressure can cause cracking.

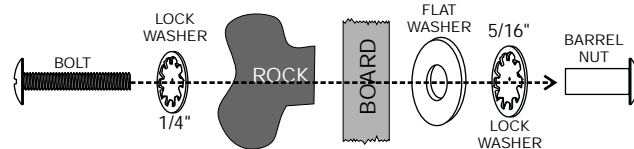

© Copyright Playground Inc

LEISURE TIME PRODUCTS

If you need assistance with parts or have assembly questions, please call Customer Service at 866-362-1123. Our regular office hours are Monday through Friday, 7:00 a.m. to 4:00 p.m. Central Time

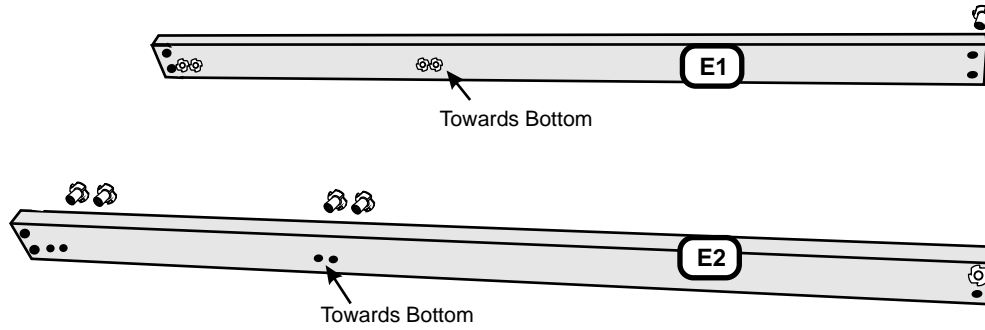

STEP 3

Attach 5/16" Spike T-Nuts to Top Hole in E1 Left Tunnel Rail and E2 Right Tunnel Rail opposite of double countersink holes. Note: 3/8" through-holes closer to bottom of E1 and E2 Rails. At this time, also install Spike T-Nuts in these four locations.

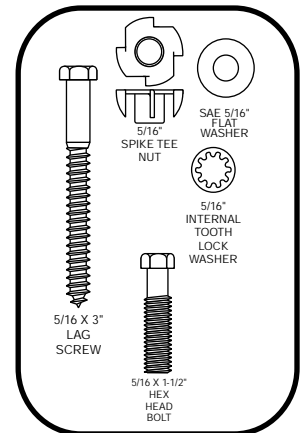
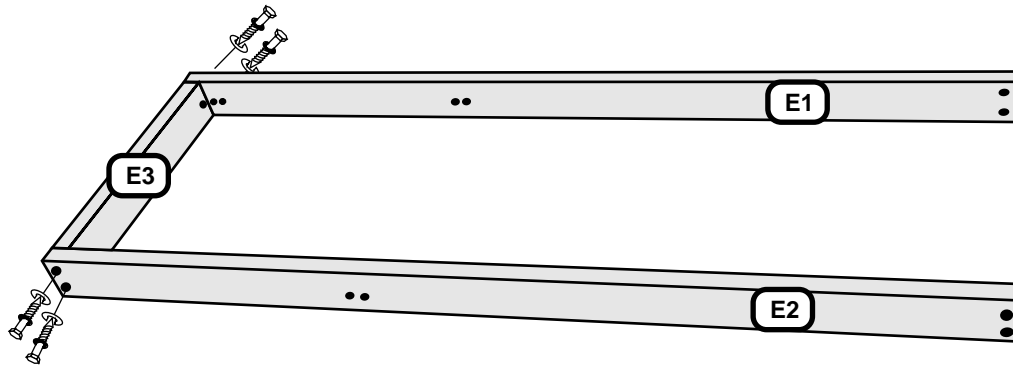

STEP 4

Now attach E3 Rock Wall Tunnel Assembly Block using a 3/16 Bit pilot drill E3. Then attach with 5/16 x 3" Lag Screws, Internal Tooth Lock Washers and Flat Washers.

STEP 5

Now attach Y27 L-Brackets to E1 and E2 Tunnel Rails in top hole only at this time. using a 5/16 x 1-1/2" Hex Bolt, Internal Tooth Lock Washers and Flat

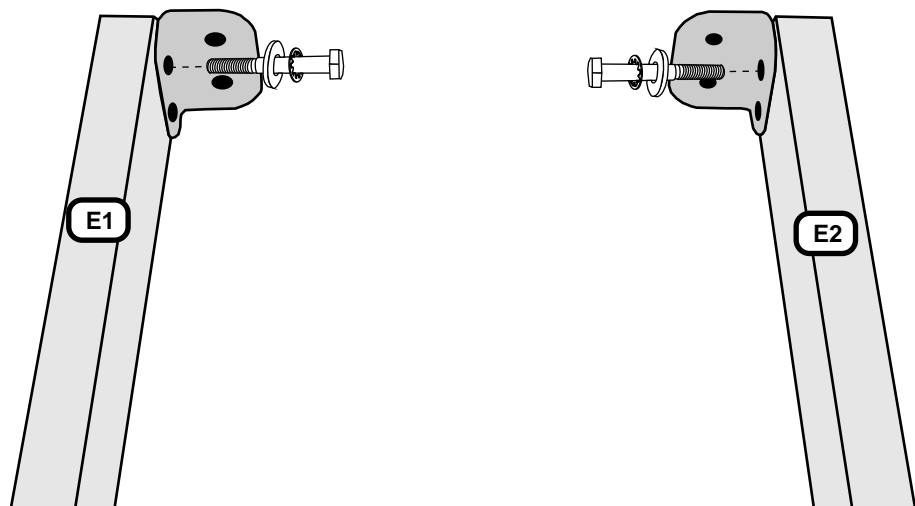

STEP 6

Noting again that the 3/8" holes are towards the ground, attach M4 Tunnel Floor Boards, one at each end, flushing to ends of E1 and E2 Rails using 2" Wood Screws. E1 and E2 Rails should be 22" from outside to outside.

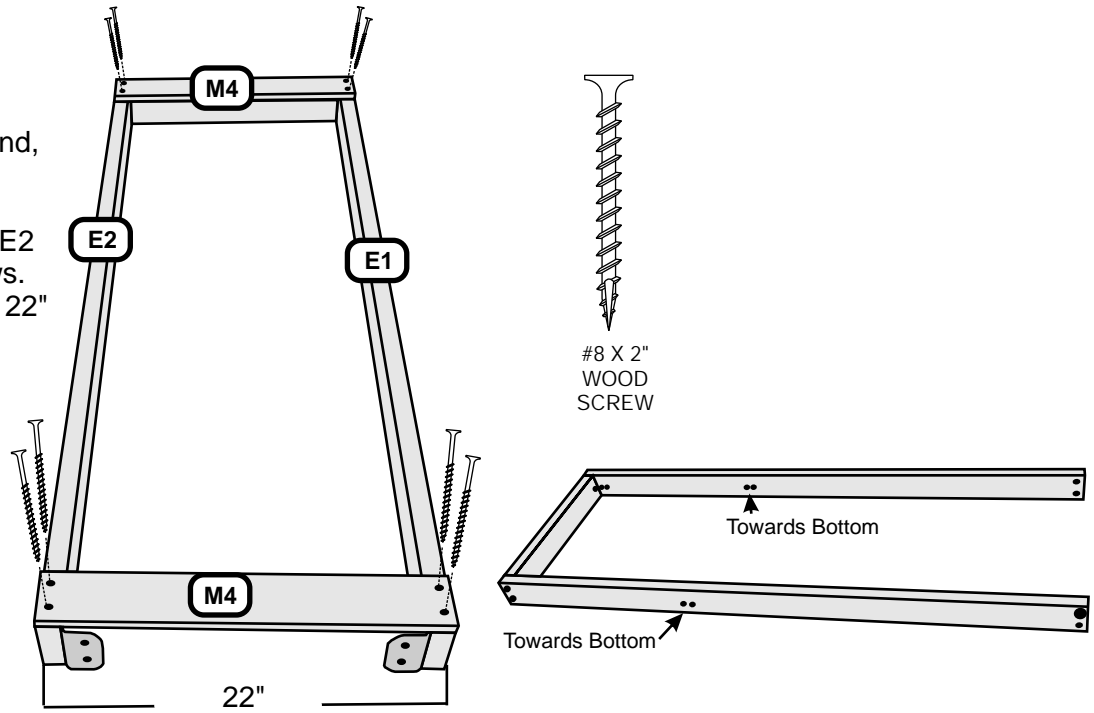

STEP 7

At this point, flip Tunnel Assembly over and attach Rock Wall Assembly to E3 End Rail, pilot drill Rock Wall Rails with 3/16" bit and attach using 3" Lag Screws, Internal Tooth Lock Washers and Flat Washers.

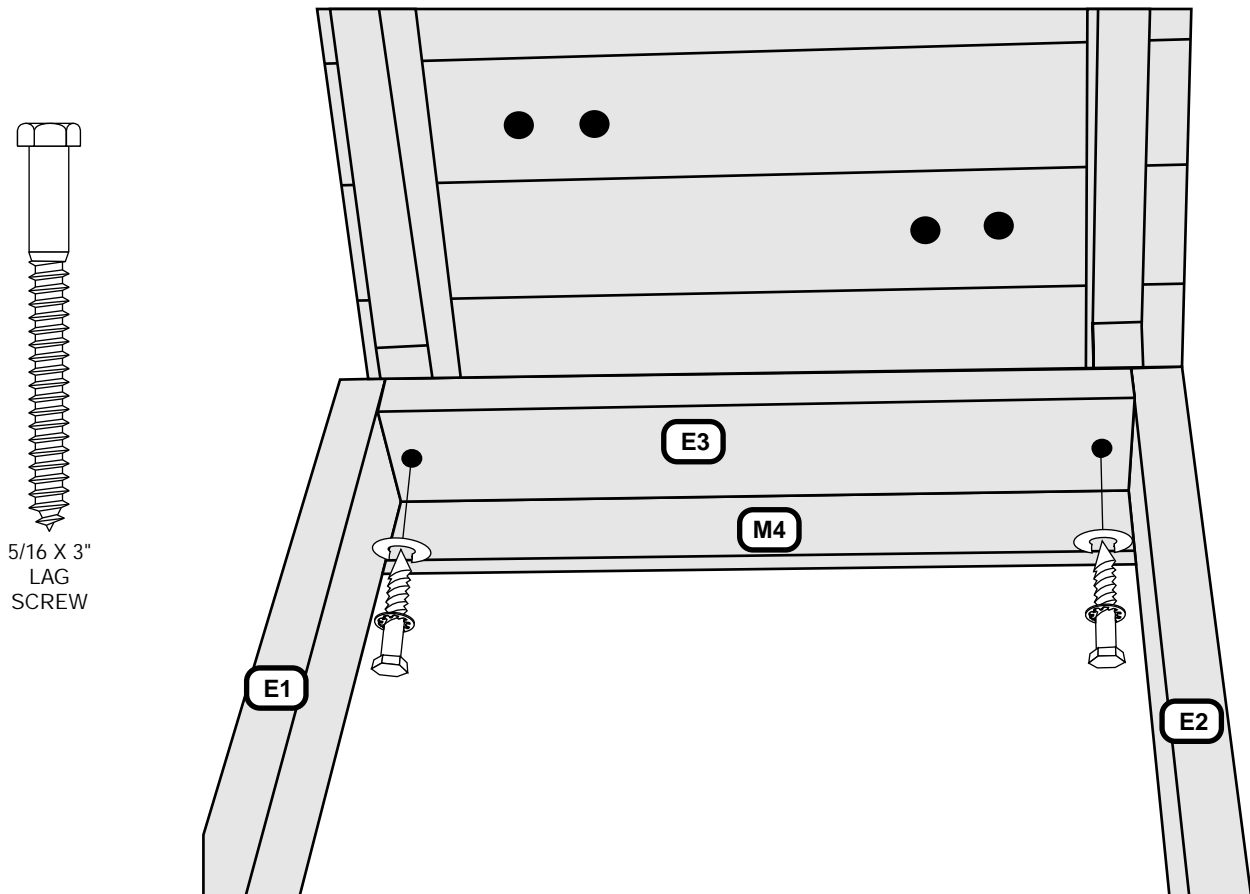

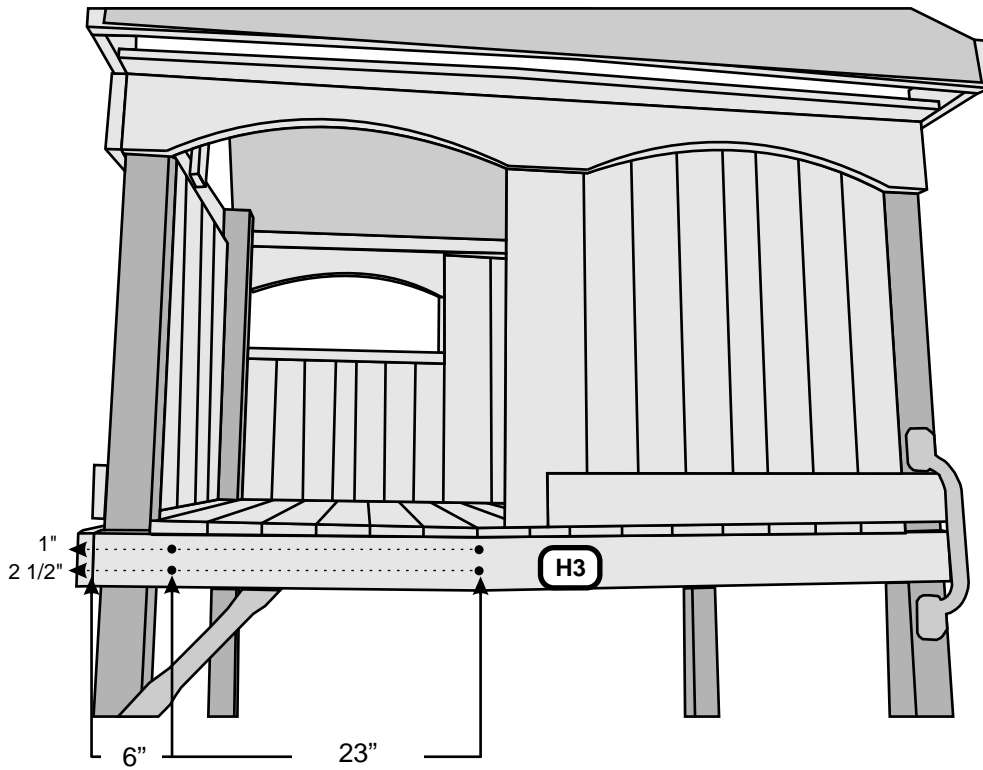

STEP 8

On Floor Rail H3 of Tower measure 6" from edge and 23" from edge at 1" and 2-1/2" from top of Rail and mark. Now using 3/8" Drill Bit, drill through the Floor Rail at these marks.

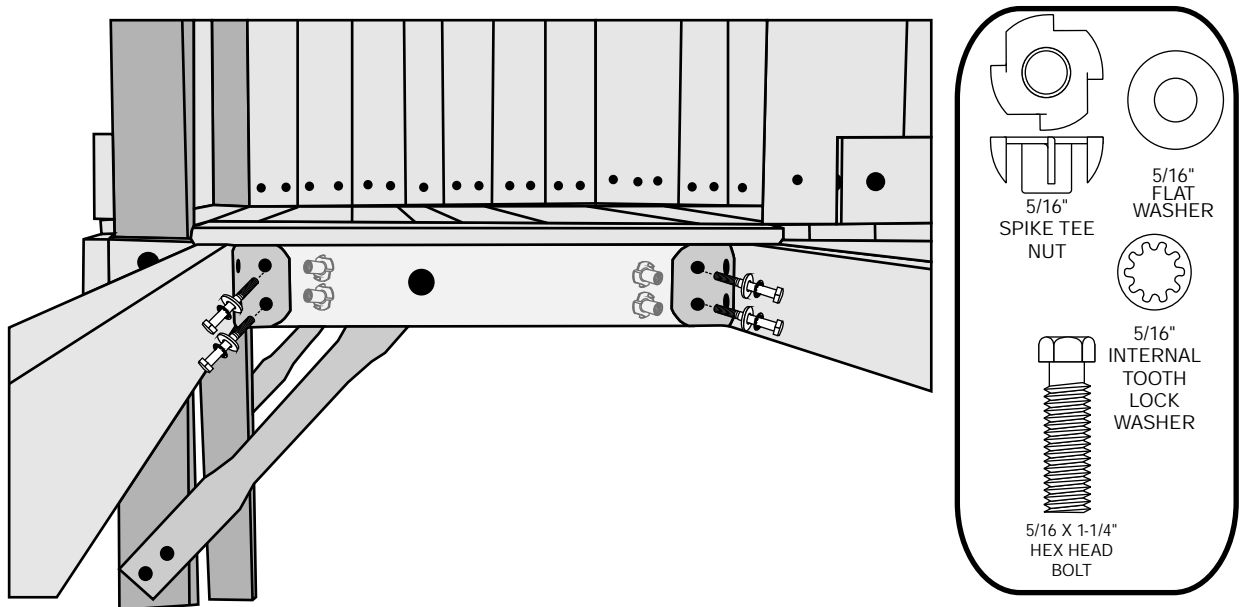

STEP 9

Now insert 5/16" Spike T-Nuts in four holes just drilled in Floor Rail from the inside. turn Tunnel Rock Wall Assembly over and attach Y27 Brackets to Floor Rail using 5/16 x 1-1/4" Hex Bolts, Internal Tooth Lock Washers and Flat Washers.

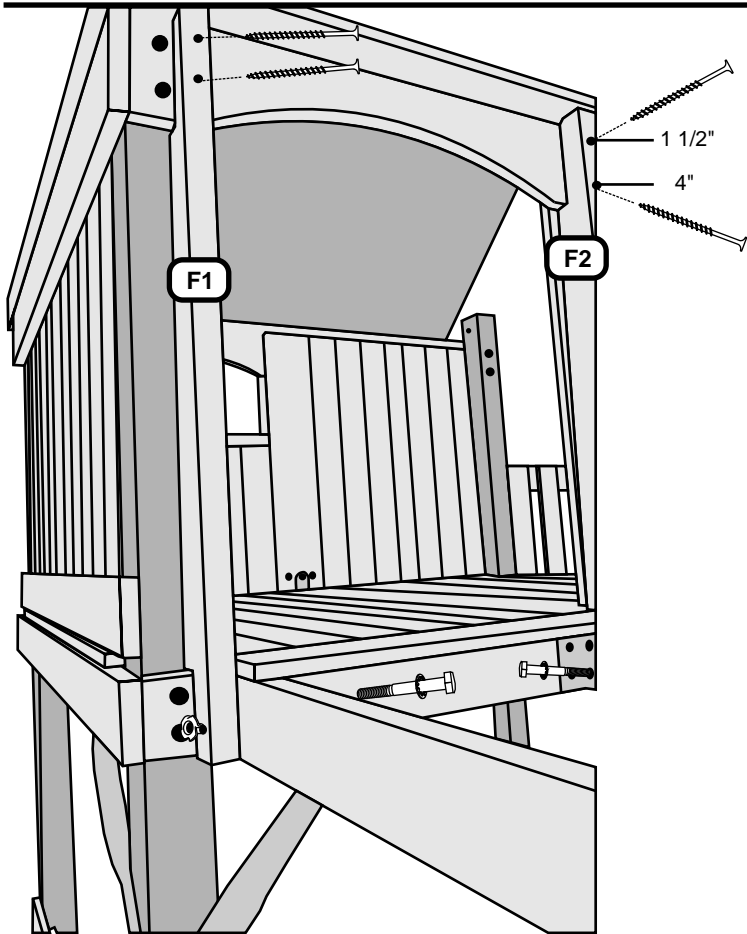

STEP 11

Now pilot drill F1 and F2 Upright at 1-1/2" and 4" from top and center of Upright using a 3/16" drill bit, plumb straight up and down, and attach using 2" Wood Screws.

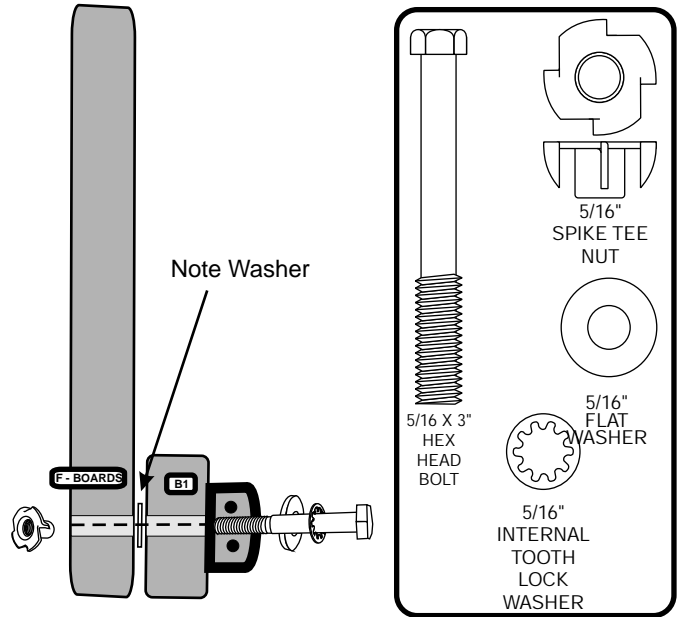

STEP 10

Insert Spike T-Nut on outside of F1 Left Tunnel Upright and F2 Right Tunnel Upright. Then using a 5/16 x 3" Hex Bolt, Internal Tooth Lock Washer and Flat Washer push through Y27 L-Bracket and into E1 and E2 Rails. Then place 5/16" Flat Washer on Bolt and attach F1 Upright to Left Tunnel Rail and F2 Upright to Right Tunnel Rail.

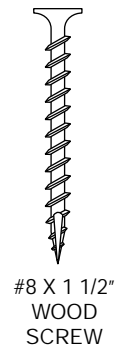
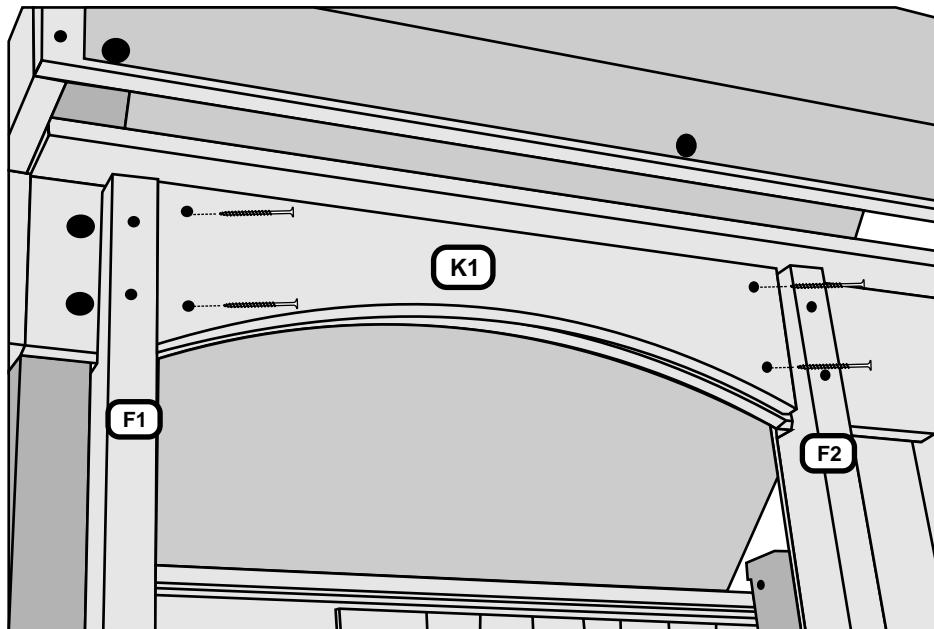

STEP 12

Now attach K1 Sculptured Tunnel Rail between F1 and F2 Uprights and attach at Sculptured Rail on Tower using 1-1/2" Wood Screws.

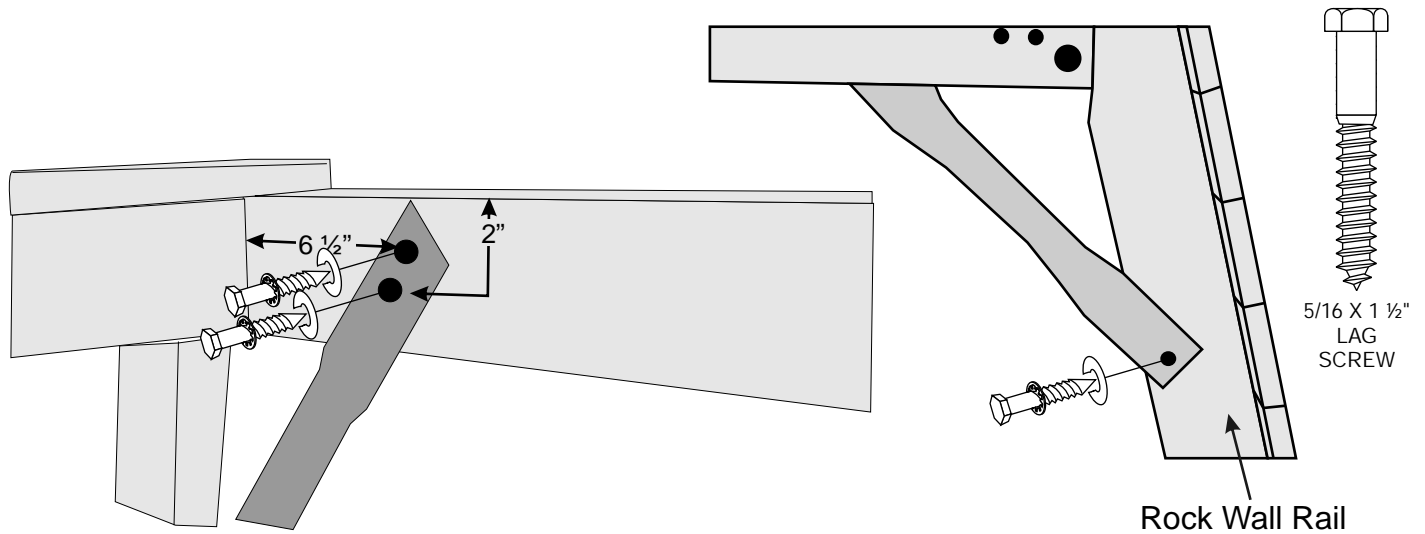

STEP 13

Attach Deck Braces to Tunnel in the inside of E1 and E2 Left and Right Tunnel Rails. Measure 6-1/2" from inside of E3 Rail and place mark 2" down from top of Tunnel Rail. Using a 3/16" drill bit, pilot drill hole. Now attach Deck Brace, double hole side, at bottom hole using 1-1/2" Lag Screw, Internal Tooth Lock Washers and Flat Washers. Pull Deck Brace around to Rock Wall Rail and again using 3/16" bit, pilot drill; attach here using 1-1/2" Lag Screw, Internal Tooth Lock Washer and Flat Washer. Now go back underneath Floor Rail and pilot drill through top hole of Deck Brace on both sides and attach with 1-1/2" Lag Screws, Internal Tooth Lock Washers and Flat Washers.

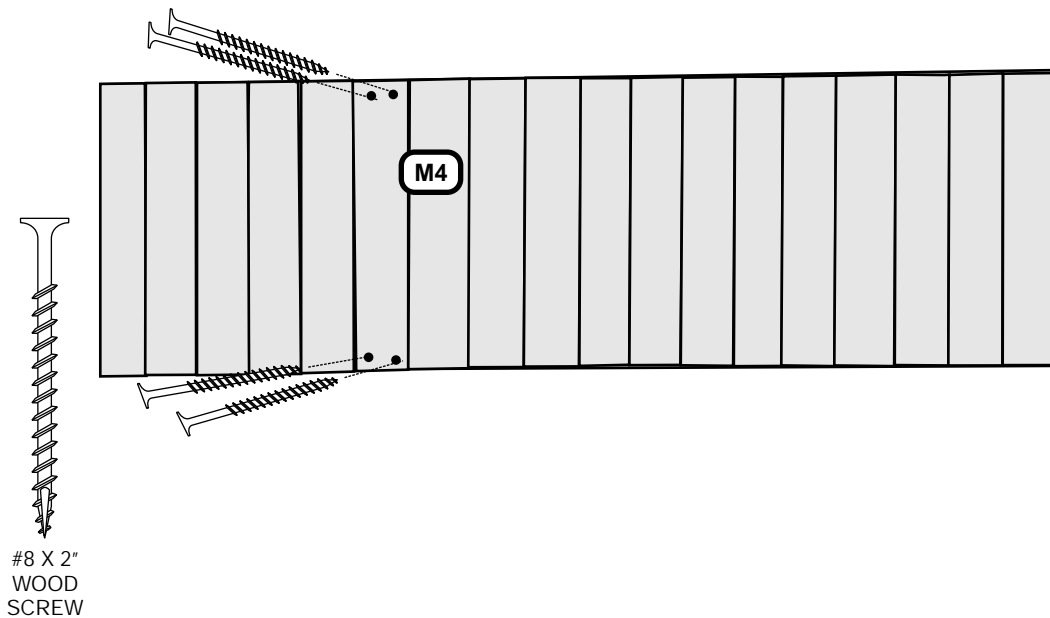

STEP 14

Spacing evenly, now attach remaining sixteen M4 Tunnel Floor Boards to E1 and E2 Rails using 2" Wood Screws.

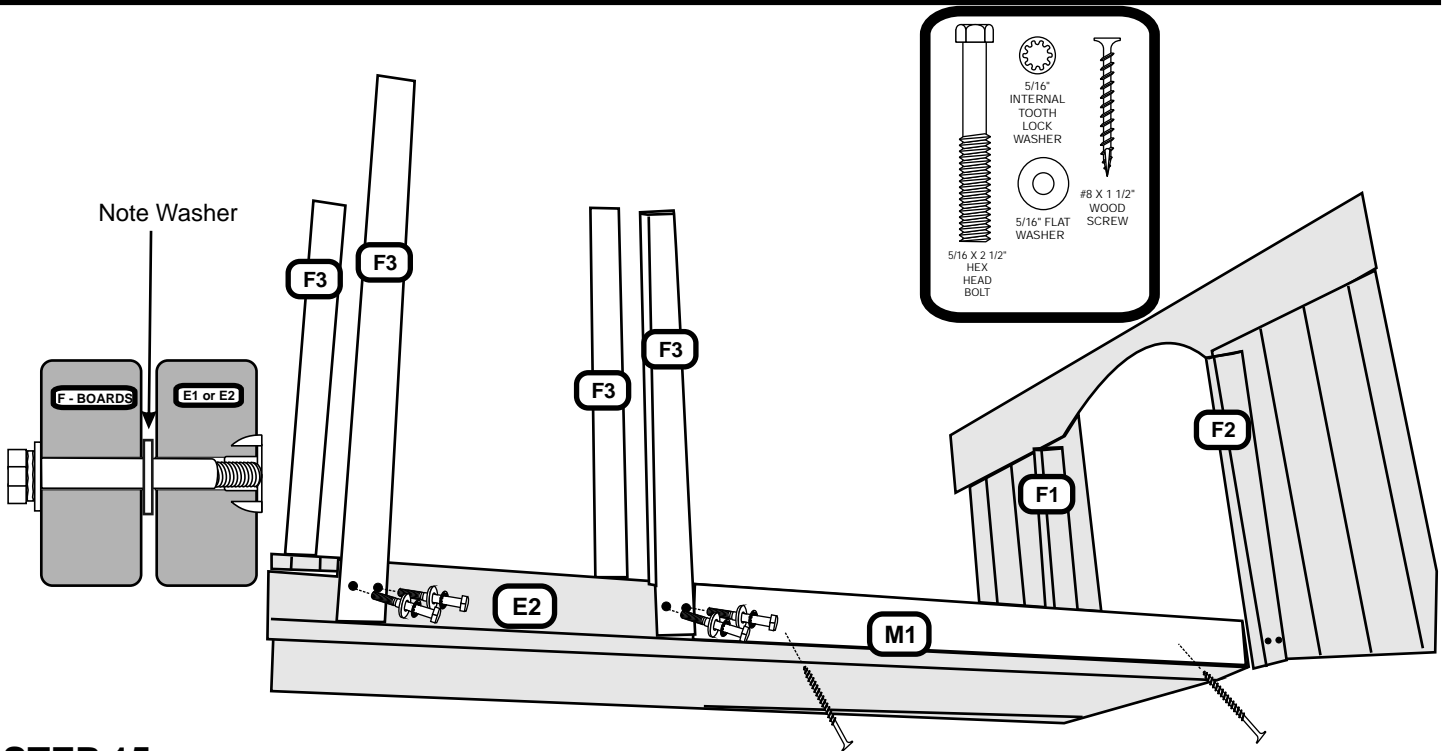

STEP 15

Attach F3 Tunnel Rail Uprights, two on E1 Left Rail and two on E2 Right Rail, using 5/16 x 2-1/2" Hex Bolts, Internal Tooth Lock Washers and Flat Washers. Push bolts through holes and place 5/16" Flat Washer on bolts so there will be a Washer between Tunnel Rails and Upright Rails. Then attach Uprights to Rails leaving loose to allow for Plastic Tunnel later in assembly.

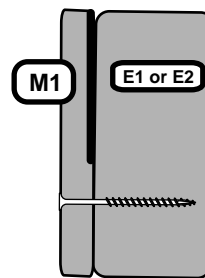

STEP 16

Attach M1 Notched Tunnel Rails on Left and Right Tunnel Rails, E1 and E2, notch in M1 towards top and flush at bottom of E1 and E2 Rails using 1-1/2" Wood Screws.

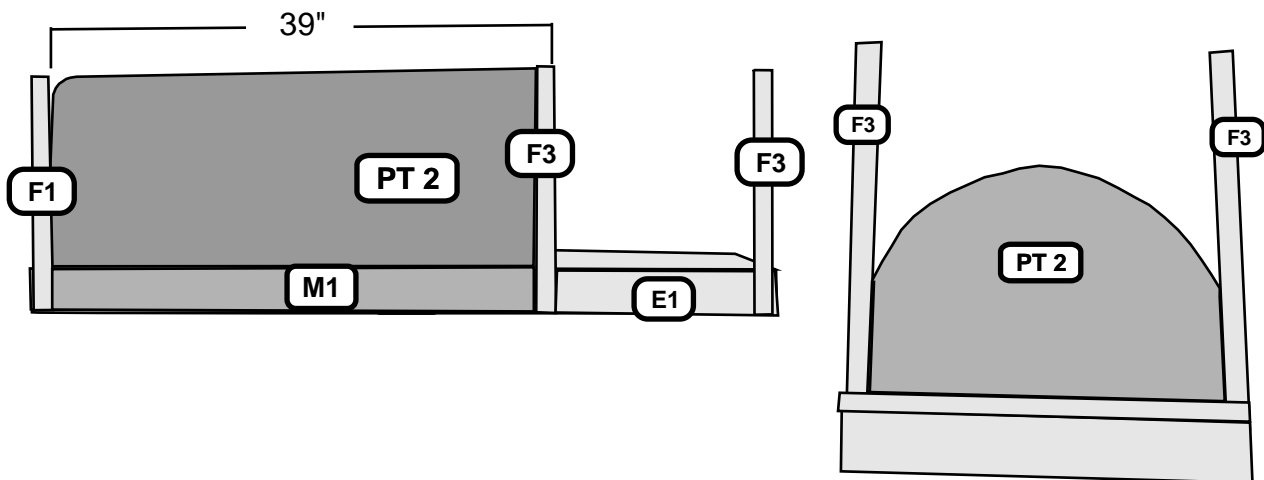

STEP 17

At this point, you may need to loosen your M1 Notched Tunnel Rail on your Left and Right E1 and E2 and your F1 and F2 Uprights to allow Plastic Tunnel, PT2, to slide between Floor Rails and these parts. When placed on the one side, push down until it bottoms out and then finish tightening all the bolts on that side. With at least two people, now you should be able to bend the Tunnel to push down on opposite Rail. Push down tight and then finish tightening all the bolts and screws on that side.

STEP 18

Place 5/16" Spike T-Nuts inside of F3 Tunnel Uprights and attach the G2 Sculptured Tunnel Rail to the F3s (closer to Tower) using 5/16 x 3-1/4" Hex Bolts, Internal Tooth Lock Washers and Flat Washers through bottom holes. Then attach G1 Sculptured Tunnel Rail to Uprights above the Rock Wall, again using 5/16 x 3-1/4" Hex Bolts, Internal Tooth Lock Washers and Flat Washers. Now, using holes in the top of the Sculptured Rails as guides, with a 3/16" drill bit, pilot hole F3 Uprights and finish attaching G1 and G2 with 2-1/2" Lag Screws, Internal Tooth Lock Washers and Flat Washers.

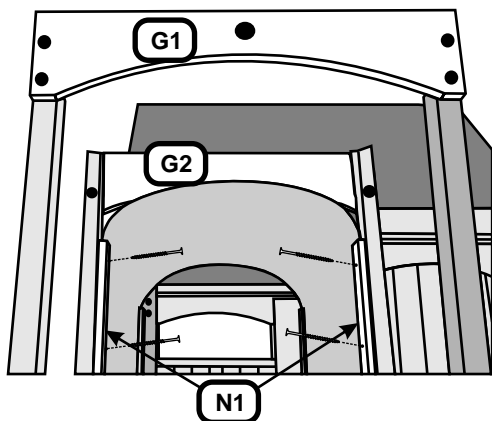
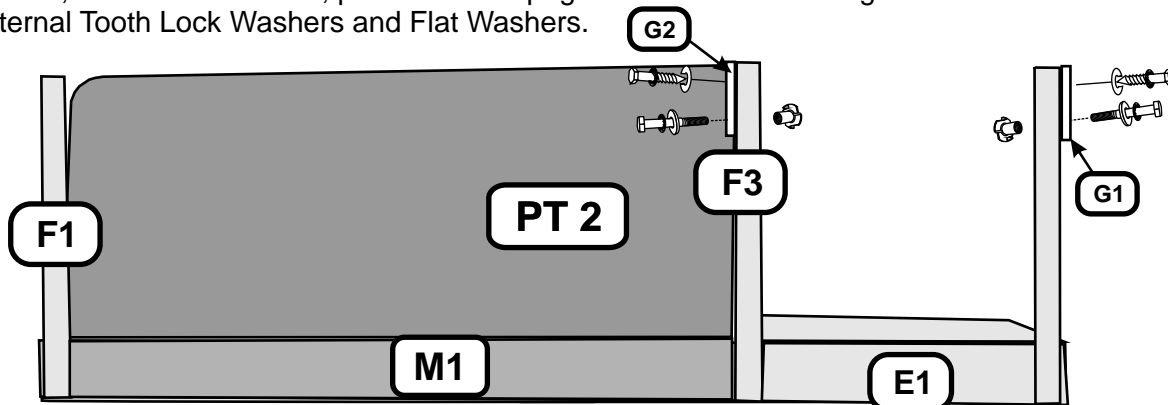

STEP 19

Attach N1s Notched Tunnel Supports to F1 and F2 Uprights at Tower and F3 Uprights toward Rock Wall on inside of Plastic Tunnel. Notches should fit over Plastic Tunnel and attach using 1-1/2" Wood Screws.

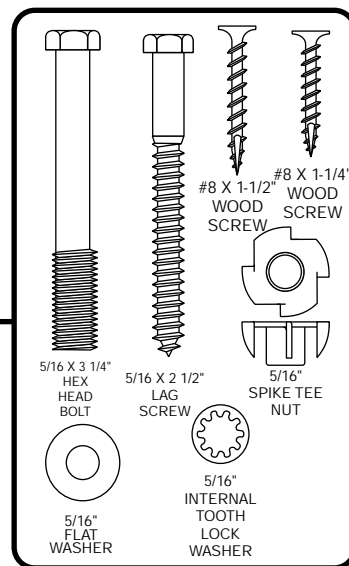

STEP 20

Attach M3 Tunnel Wall Rails to inside of F3 Uprights flushing with Tops of F3s and fasten using 1-1/2" Wood Screws. Someone may need to push the Uprights together so M3s fit snug against the Sculptured Rails G2 and G1.

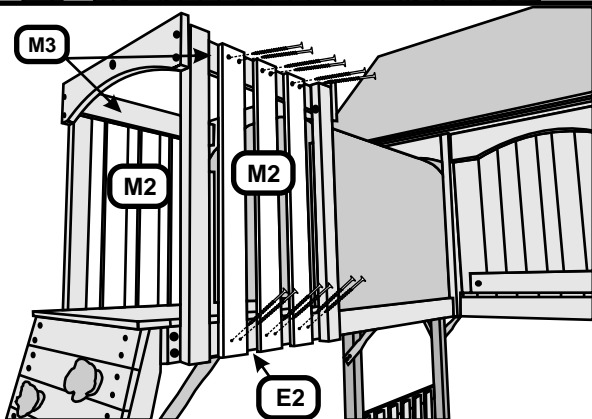

STEP 21

Attach M2 Tunnel Wall Boards, three per each side, on outside of M3s, E1 and E2 Left and Right Rails spacing approximately 2" apart using 1-1/2" Wood Screws flushing at bottom of E1 and E2 Rails and 1-1/4" Wood Screws at top at M3s.

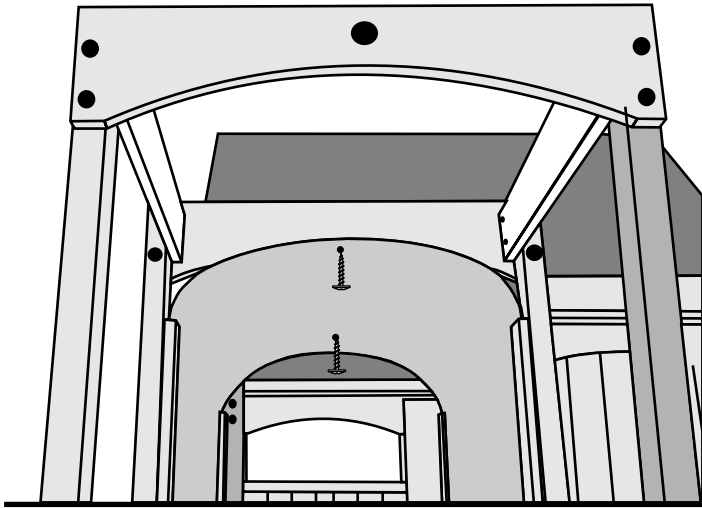

STEP 22

From the inside of the Tunnel, mark approximation of Sculptured Rails at opening, entrance and exit of Tunnel and from inside using a 3/4" Washer Head Screw, screw through the Plastic Tunnel into the Sculptured Rails.

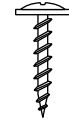

#8 X 3/4"
WASHER
HEAD
SCREW

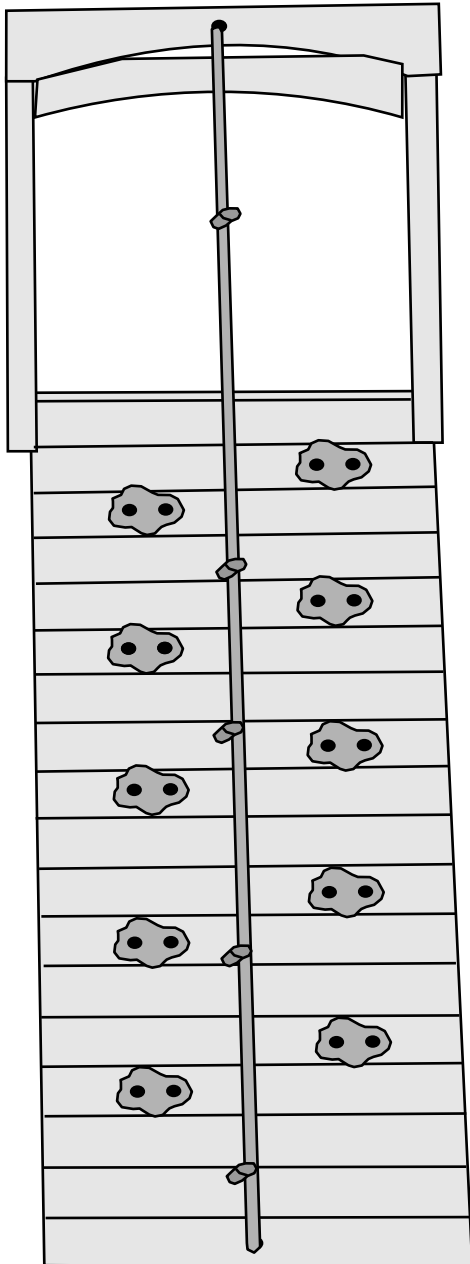

STEP 23

Now attach Rope through Top Sculptured Rail, tie knot. Then tie five more knots approximately eighteen inches apart. Then attach to Bottom Rock Wall Board pulling tight enough so Rope cannot be looped back on itself and tie knot inside of Bottom Rock Board.

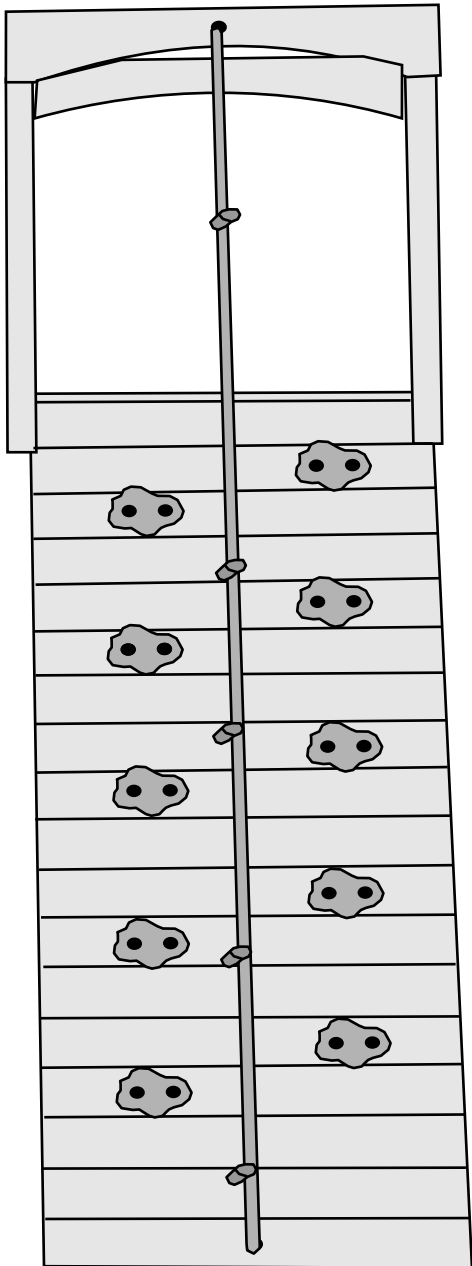

Front View

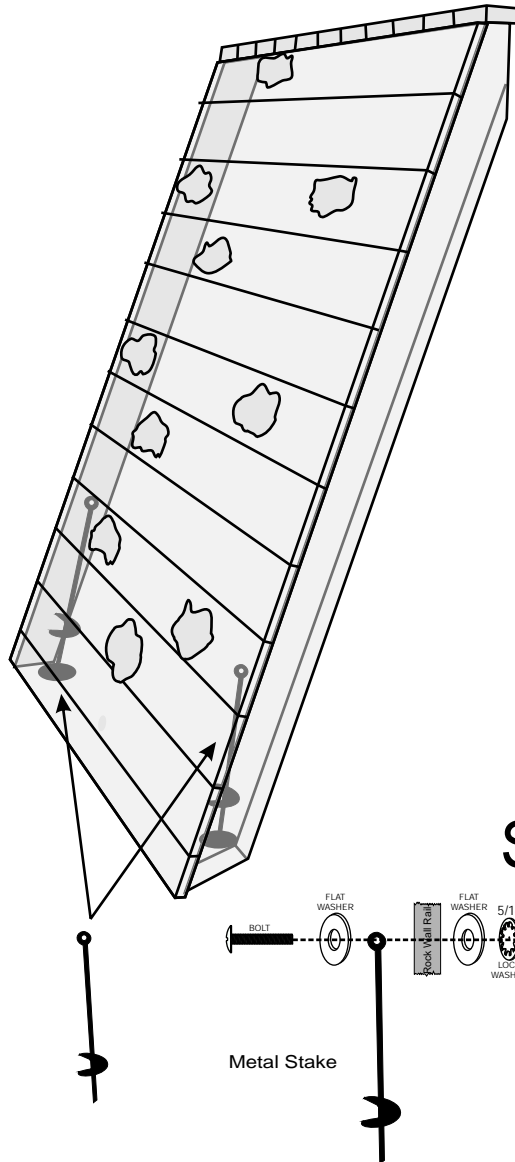

Side View

STEP 24

Now is the time to secure the Rock Wall to the ground by using the stakes in the locations shown by the black circles.

Metal stake installation: You will need a long screwdriver for leverage. In some cases you may need to dig a hole to install stake and cement.

Use hole in stake as guide to drill 3/8" pilot hole thru base board use 1" phillips truss head bolt, 5/16" flat washer thru stake into Rock Wall Rails 5/16" flat washer, 5/16" lock washer on barrel nut attach to base board.

LEISURE TIME PRODUCTS

P.O. Box 459 • Siloam Springs, AR 72761

Parte # 5027

TÚNEL

Última Generación

INSTRUCCIONES DE ENSAMBLAJE

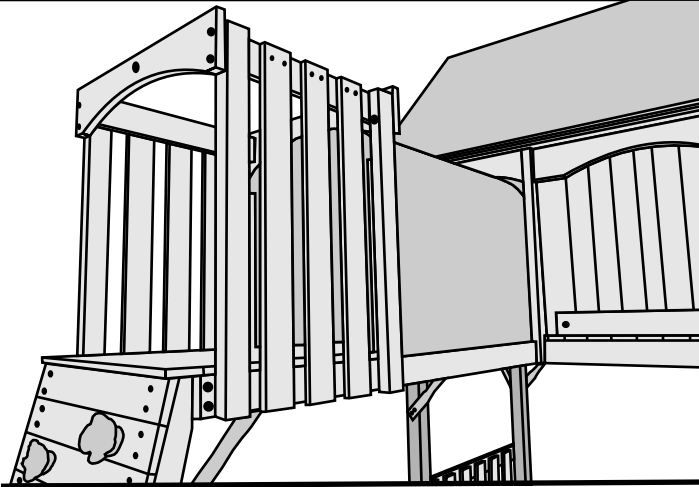

Atención: Este kit de túnel necesita 1 kit de pared de rocas para fijación. (Los dos pasos siguientes muestran la construcción de la pared de rocas). Desenrolle el túnel plástico y coloque peso sobre él para que se aplane.

PASO 1

Coloque los largueros de la pared de rocas E1 y luego fije 1 tablilla de pared de rocas M3 a 1/8 in. (3,2 mm) de la parte superior de los largueros. La tablilla de la pared sobresaldrá aproximadamente 1-5/16 in. (3,3 cm) sobre el larguero. Los largueros de la pared de rocas E1 deberán estar aproximadamente 19-1/2 in. (49,5 cm) de parte externa a parte externa. Fije utilizando tornillos para madera de 2 in. (5,1 cm) y fije la tablilla del larguero inferior M2 aproximadamente a 1/8 in. (3,2 mm) de la parte inferior del larguero.

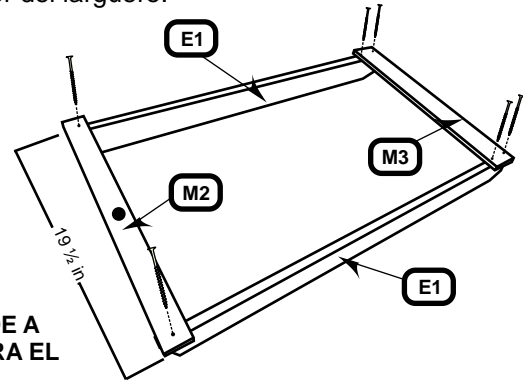
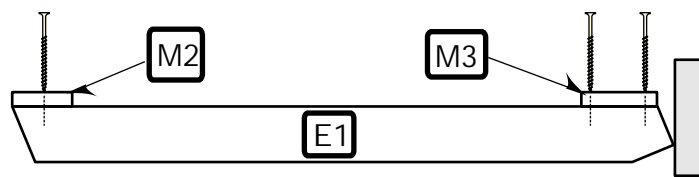

SUGERENCIA: PARA CONTRIBUIR A QUE LA PARED DE ROCAS QUEDE A ESCUADRA, PRESIONE LOS EXTREMOS DE LOS LARGUEROS CONTRA EL TABLERO A TIERRA DE LA UNIDAD

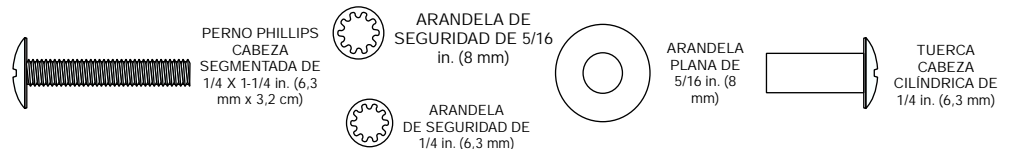
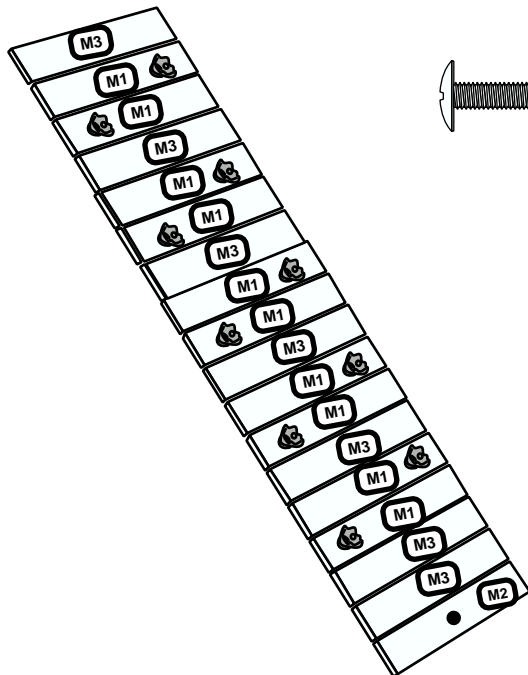

PASO 2

Fije todas las rocas verdes plásticas a los tableros de pared de rocas M1 utilizando pernos Phillips cabeza segmentada de 1/4x1 in. (6,3 mm x 2,5 cm) a través de la roca y luego de la tablilla y la arandela plana de 5/16 in. (8 mm), la arandela ITLW de 5/16 in. (8 mm) y las tuercas cilíndricas. Alterne las tablillas M1 como aparece en el diagrama, observando que en cada tercera tablilla hay una M3 sin rocas en ella (no hay rocas en las últimas 3 tablillas). Apriete de forma segura pero no demasiado. La presión excesiva puede ocasionar rajaduras.

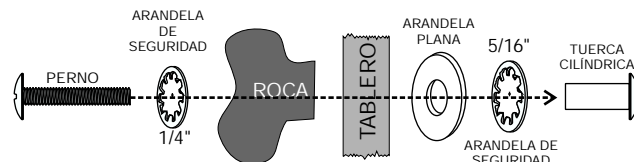

© Copyright Playground Inc

PRODUCTOS LEISURE TIME

Si necesita ayuda con las partes o tiene preguntas sobre el ensamblaje, por favor llame al Dpto. de Servicio al Cliente al 866-362-1123. Nuestras horas regulares de oficina son de lunes a viernes, de 7:00 a.m. a 4:00 p.m. Hora Central.

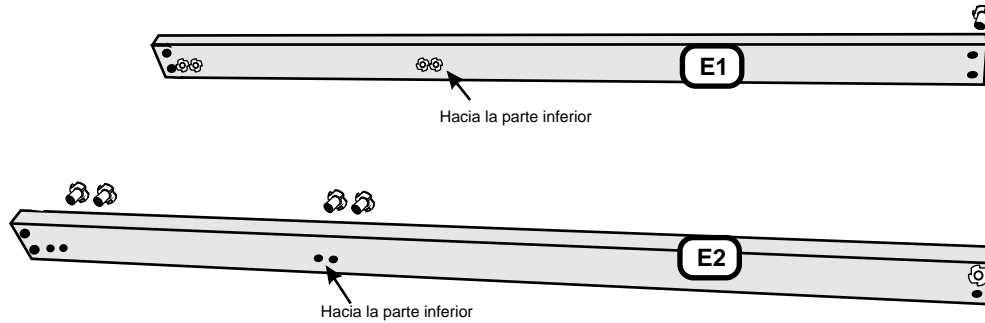

PASO 3

Fije tuercas en T de 5/16 in. (8 mm) con espiga al agujero superior en el larguero izquierdo E1 del túnel y el larguero derecho E2 del túnel opuesto a los agujeros dobles avellanados. Nota: Los agujeros de 3/8 in. (9,5 mm) están más cercanos a la parte inferior de los largueros E1 y E2. En este momento, también coloque las tuercas en T con espiga en estas cuatro ubicaciones.

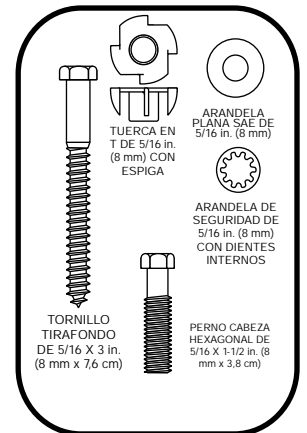
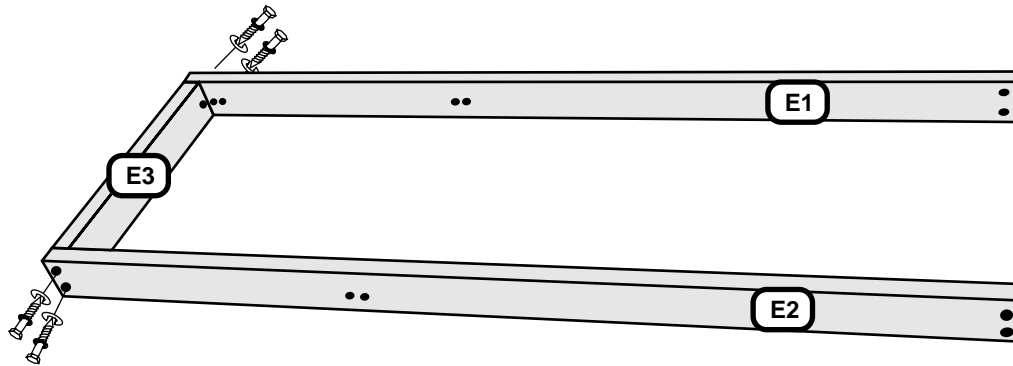

STEP 4

Ahora fije el bloque de ensamble del túnel de la pared de rocas haciendo un agujero piloto con una broca de 3/16 in. (4,8 mm) en E3. Luego fije con tornillos tirafondo de 5/16 x 3 in. (8 mm x 7,6 cm), arandelas de seguridad con dientes internos y arandelas planas.

PASO 5

Ahora fije los soportes en L Y27 a los largueros de túnel E1 y E2 en el agujero superior únicamente en este momento, utilizando un perno hexagonal de 5/16 x 1-1/2 in. (8 mm x 3,8 cm), arandelas de seguridad con dientes internos y arandelas planas.

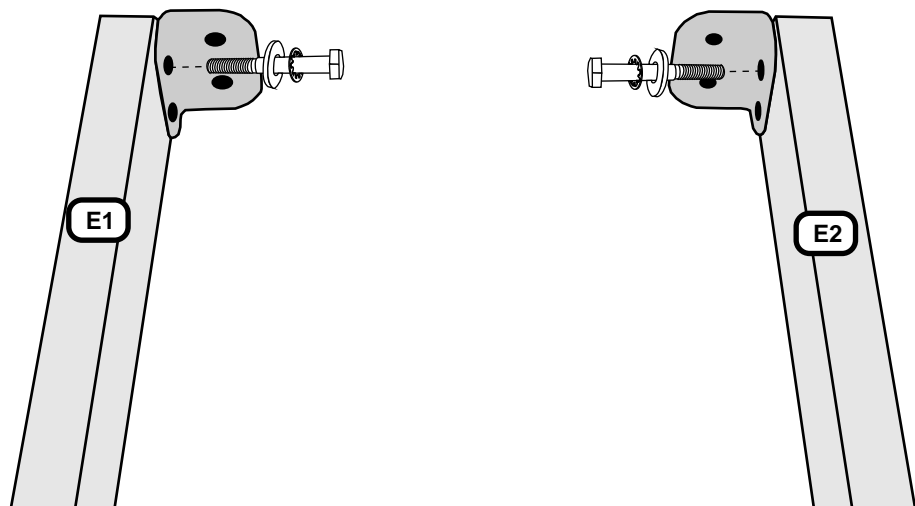

PASO 6

Observando de nuevo que los agujeros de 3/8 in. (9,5 mm) están orientados hacia la tierra, fije los tableros de piso M4 del túnel, uno en cada extremo, a ras de los largueros E1 y E2 utilizando tornillos para madera de 2 in. (5,1 cm). Los largueros E1 y E2 deberán estar a 22 in. (55,9 cm) de parte externa a parte externa.

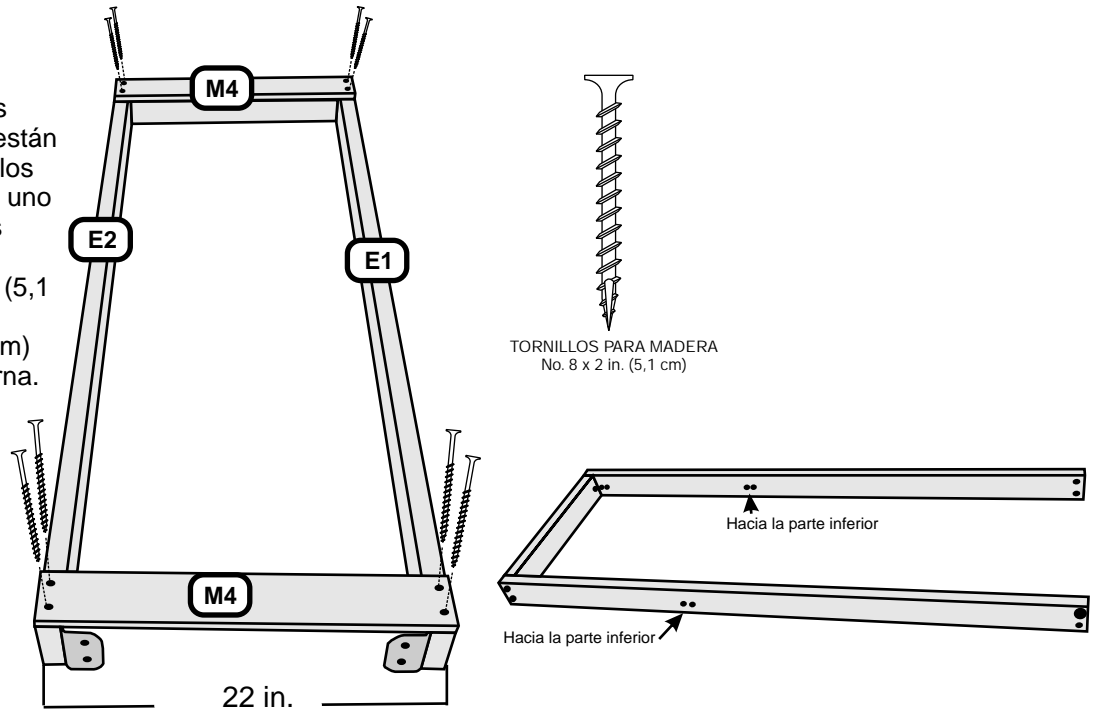

PASO 7

En este punto, déle vuelta al ensamble del túnel y fije el ensamble de pared de rocas al larguero de extremo E3, perfore agujeros piloto en los largueros de la pared de rocas con una broca de 3/16 in. (4,8 mm) y fije utilizando tornillos tirafondo de 3 in. (7,6 cm), arandelas de seguridad de dientes internos y arandelas planas.

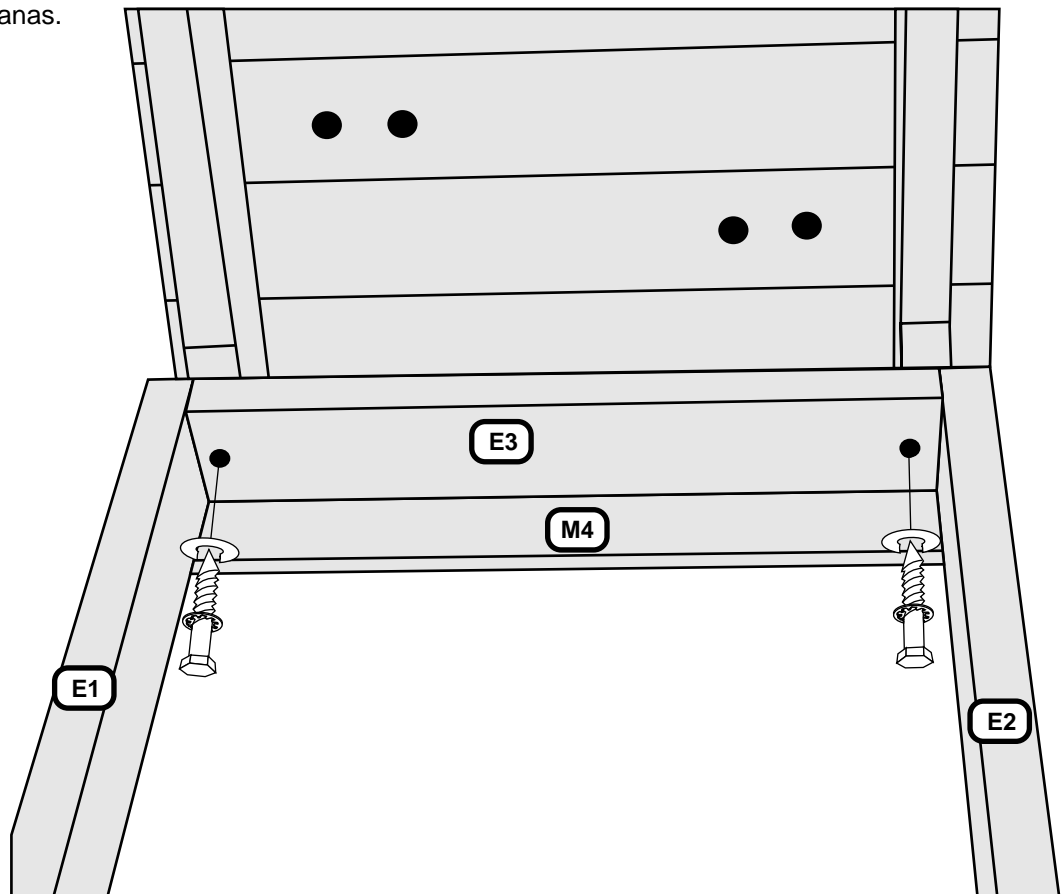
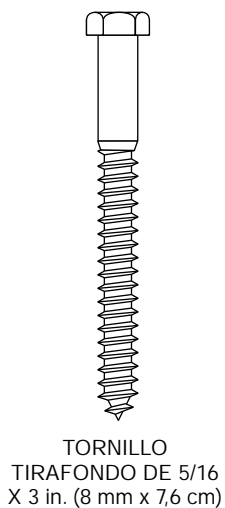

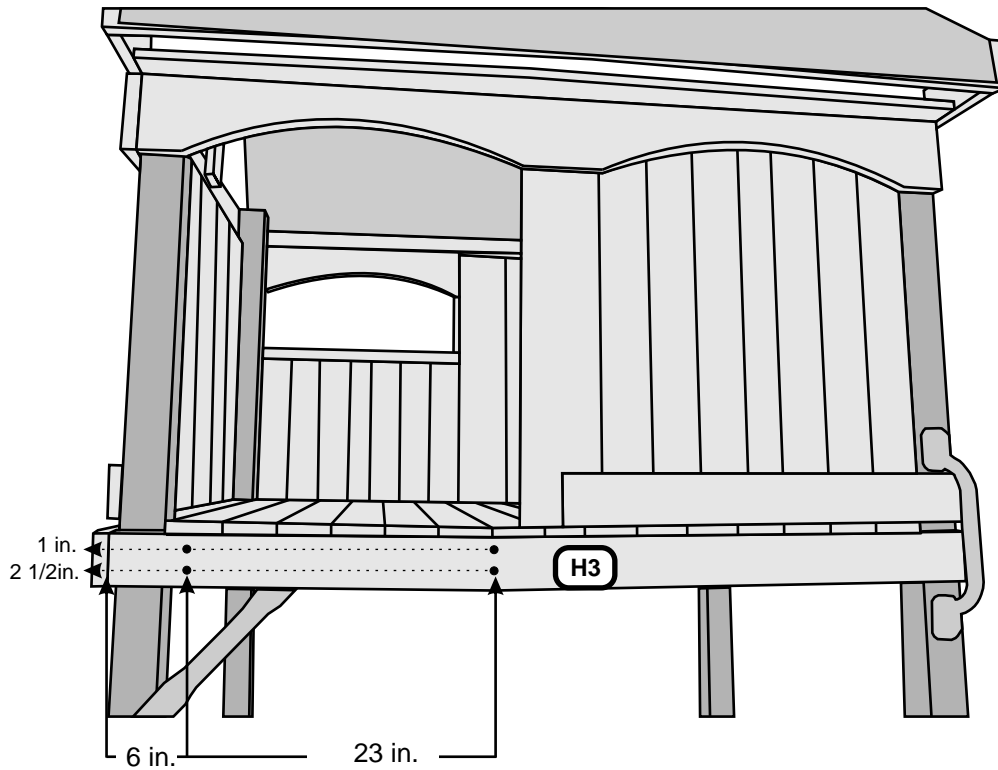

PASO 8

En el larguero H3 del piso de la torre mida 6 in. (15,2 cm) del extremo y 23 in. (58,4 cm) del extremo a 1 in. (2,5 cm) y 2-1/2 in. (6,4 cm) de la parte superior del larguero y marque. Ahora usando una broca de taladro de 3/8 in. (9,5 mm), taladre el larguero de piso en estas marcas.

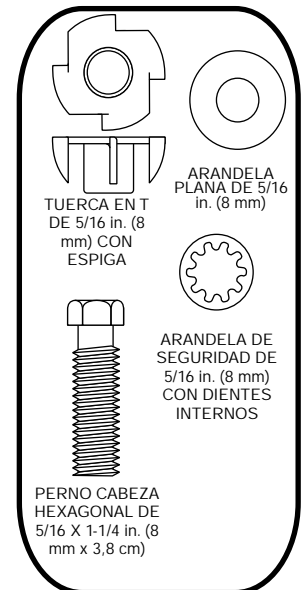
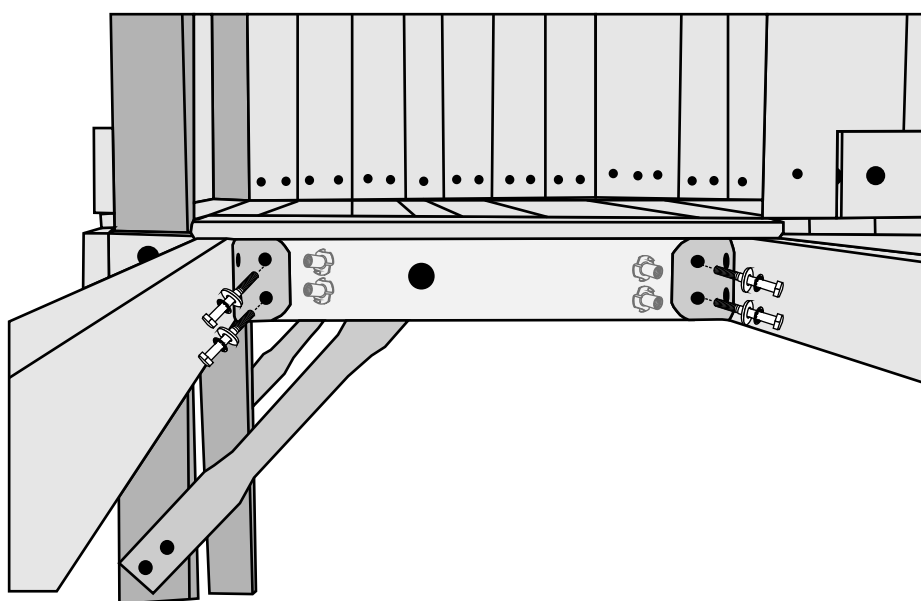

PASO 9

Ahora inserte las tuercas de 5/16 in. (8 mm) en T con espigas en los cuatro agujeros que acaba de taladrar en el larguero de piso desde el interior. Déle vuelta al ensamble de la pared de rocas del túnel y fije los soportes Y27 al larguero de piso utilizando pernos hexagonales de 5/16 in. (8 mm) x 3,1 cm, arandelas de seguridad con dientes internos y arandelas planas.

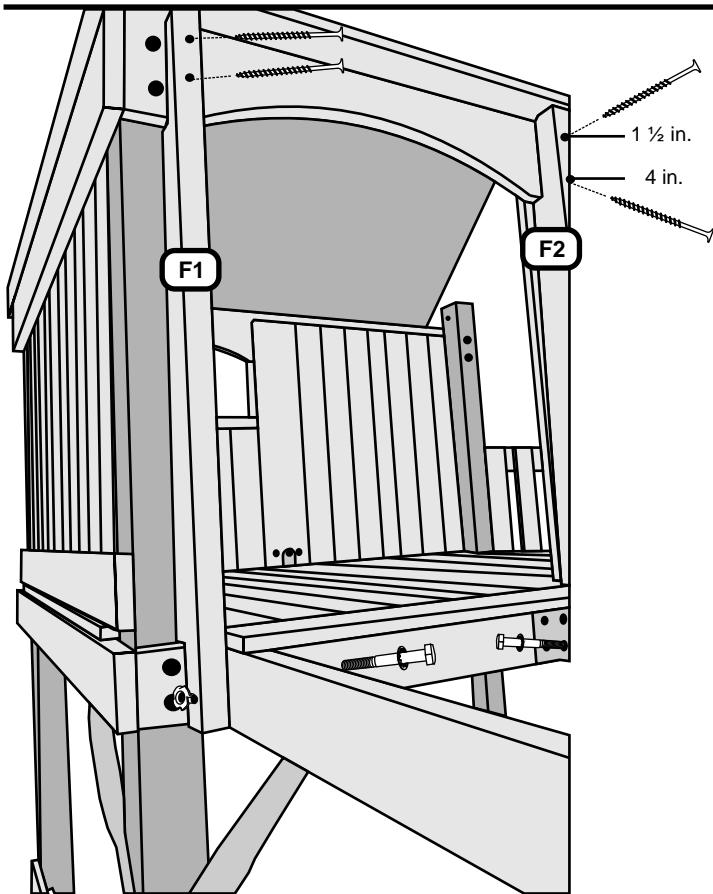

PASO 11

Ahora perfora un agujero piloto en los parales F1 y F2 a 1-1/2 in. (3,8 cm) y 4 in. (10,1 cm) del borde superior y centro del paral utilizando una broca de 3/16 in. (4,8 mm) para taladro, aplome hacia arriba y hacia abajo y fije utilizando tornillos para madera de 2 in. (5,1 cm).

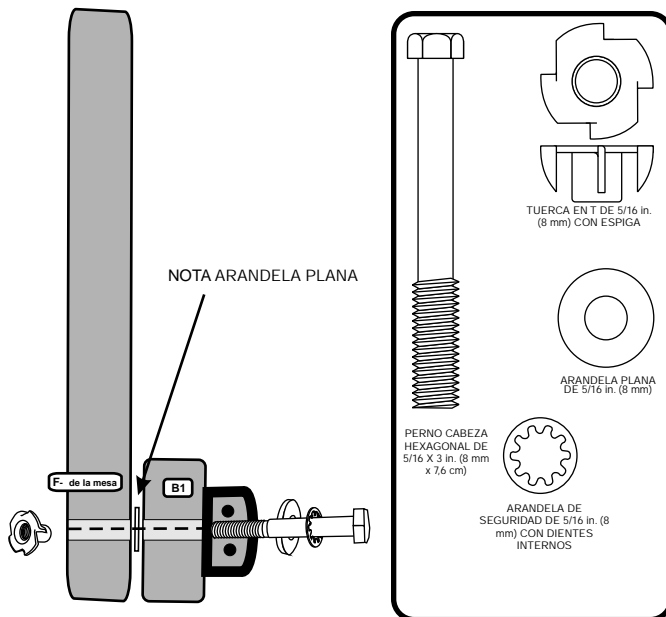

NOTA ARANDELA PLANA

F. de la mesa

B1

TUERCA EN T DE 5/16 in. (8 mm) CON ESPIGA

ARANDELA PLANA DE 5/16 in. (8 mm)

PERNO CABEZA HEXAGONAL DE 5/16 X 3 in. (8 mm x 7,6 cm)

ARANDELA DE SEGURIDAD DE 5/16 in. (8 mm) CON DIENTES INTERNOS

PASO 10

Inserte una tuerca en T con espigas en la parte externa del paral vertical izquierdo del túnel y el paral F2 derecho del túnel. Luego utilizando un perno hexagonal de 5/16 x 3 in. (8 mm x 7,6 cm), una arandela de seguridad con dientes internos y una arandela plana, empuje a través de un soporte en L Y27 y dentro de los largueros E1 y E2. Luego coloque la arandela plana de 5/16 in. (8 mm) en el perno y fije el paral F1 al larguero izquierdo del túnel y el paral F2 al larguero derecho del túnel.

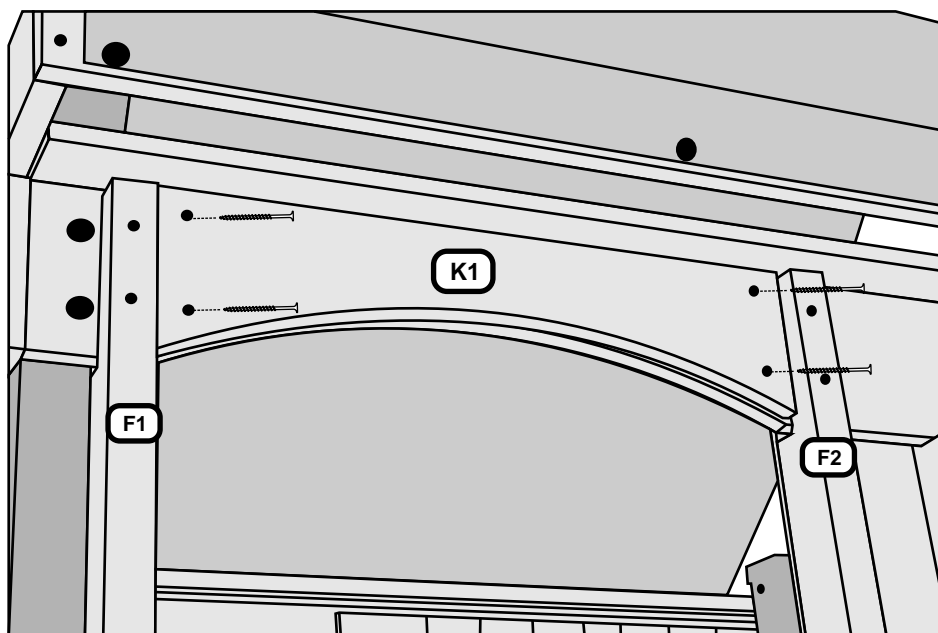

TORNILLOS PARA MADERA No. 8 x 1-1/2 in. (3,8 cm)

PASO 12

Ahora fije el larguero de túnel tallado K1 entre los parales F1 y F2 y fije un larguero tallado en la torre utilizando tornillos de madera de 1-1/2 in. (3,8 cm).

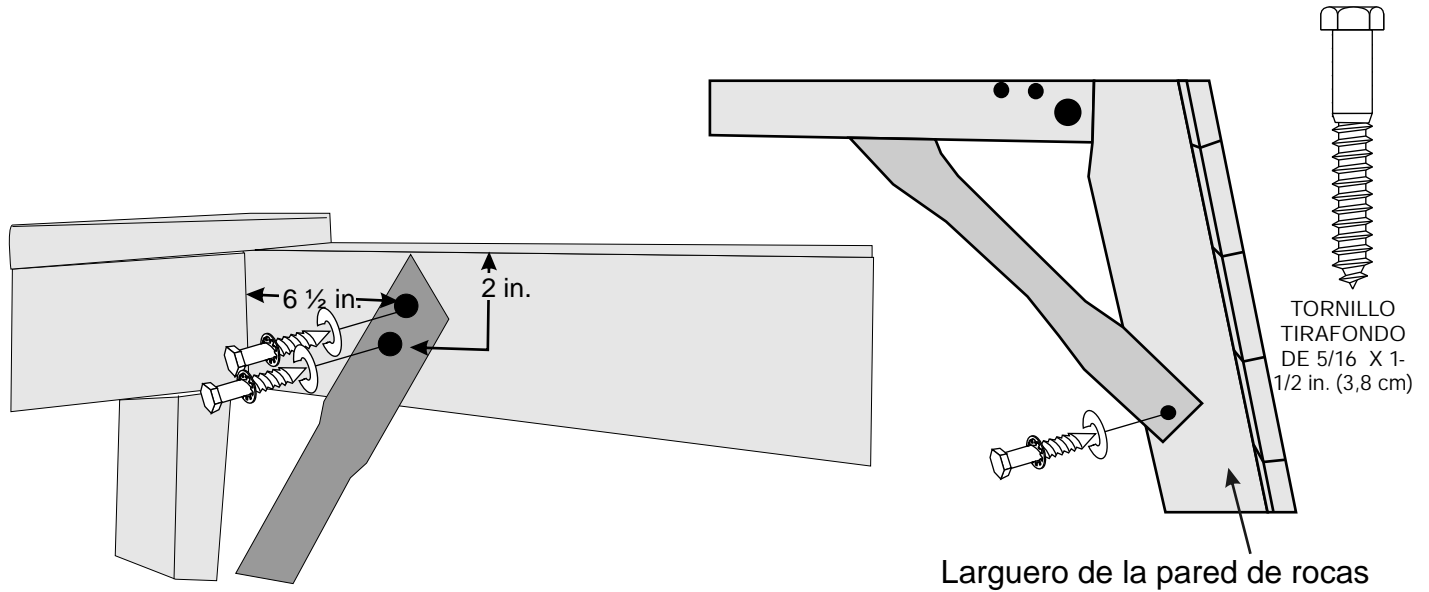

PASO 13

Coloque las abrazaderas de la plataforma al túnel en la parte interior de E1 y E2 de los largueros izquierdo y derecho del túnel. Mida 6-1/2 in. (16,5 cm) de la parte interna del larguero E3 y coloque la marca 2 in. (5,1 cm) hacia abajo de la parte superior del larguero del túnel. Utilizando una broca de taladro de 3/16 in. (4,8 mm) perfore un agujero piloto. Ahora fije la abrazadera de la plataforma, de doble agujero lateral en el agujero inferior, utilizando tornillo tirafondo de 1-1/2 in. (3,8 cm), arandela de seguridad de dientes internos y arandelas planas. Dirija la abrazadera de la plataforma hacia el larguero de la pared de rocas y de nuevo, utilizando una broca de 3/16 in. (4,8 mm), perfore un agujero piloto; fije aquí utilizando un tornillo tirafondo de 1-1/2 in. (3,8 cm), arandela de seguridad de dientes internos y arandela plana. Ahora regrese al larguero de piso de abajo y taladre un agujero piloto a través del agujero superior de la abrazadera de la plataforma en ambos lados y fije con tornillos tirafondo de 1-1/2 in. (3,8 cm), arandelas de seguridad con dientes internos y arandelas planas.

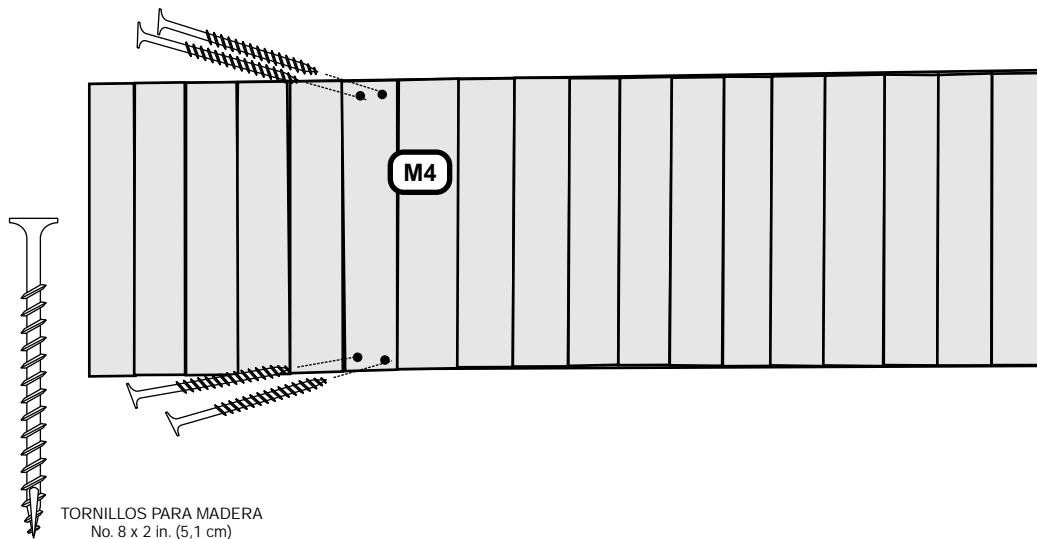

PASO 14

Espaciando uniformemente, ahora fije los restantes dieciséis tableros M4 para el piso del túnel a los largueros E1 y E2 utilizando tornillos para madera de 2 in. (5,1 cm).

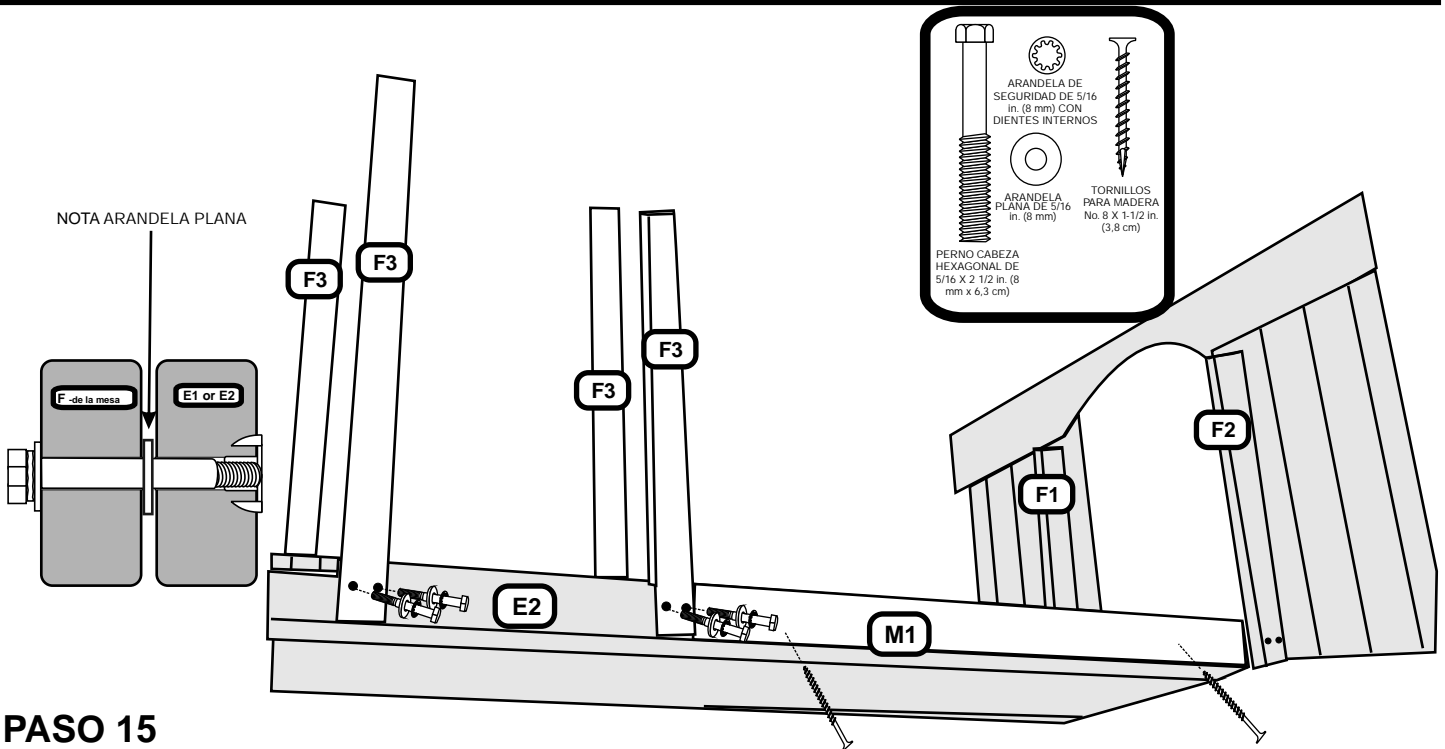

PASO 15

Fije los parales F3 de los largueros del túnel, dos en el larguero izquierdo E1 y dos en el larguero derecho E2, utilizando pernos hexagonales de 5/16 x 2-1/2 in. (8 mm x 5,7 cm), arandelas de seguridad con dientes internos y arandelas planas. Empuje los pernos a través de los agujeros y coloque una arandela plana de 5/16 in. (8 mm) en los pernos de modo que haya una arandela entre los largueros del túnel y los parales verticales. Luego fije los parales a los largueros dejándolos flojos para permitir la colocación del túnel plástico más tarde en el ensamble.

PASO 16

Fije los largueros de túnel M1 con muescas a los largueros de túnel izquierdo y derecho, E1 y E2, la muesca en M1 orientada hacia la parte superior y a ras en la parte inferior de los largueros E1 y E2 utilizando tornillos para madera de 1-1/2 in. (3,8 cm).

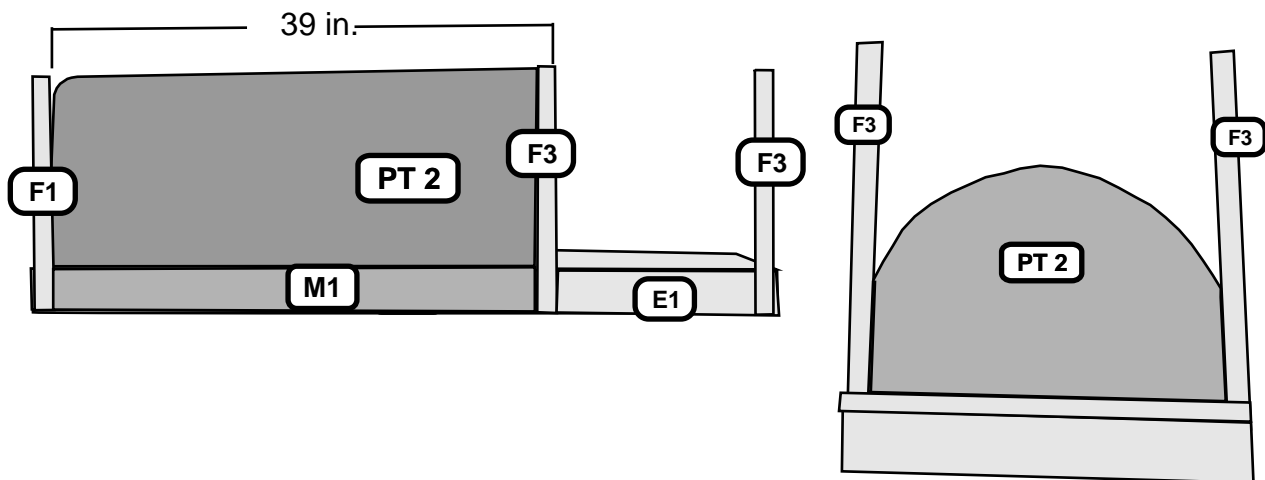
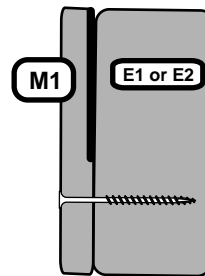

PASO 17

En este punto es posible que necesite aflojar el larguero de túnel con muesca M1 en el E1 y E2, izquierdo y derecho respectivamente y los parales F1 y F2 para permitir que el túnel plástico, PT2, se deslice entre los largueros de piso y estas partes. Cuando esté colocado en un lado, presione hacia abajo hasta que sobresalga y luego termine apretando todos los pernos de ese lado. Con dos personas por lo menos, ahora podrá doblar el túnel para presionar hacia abajo en el larguero opuesto. Presione hacia abajo apretando y luego termine de apretar todos los pernos y tornillos de ese lado.

PASO 18

Coloque las tuercas en T de 5/16 in. (8 mm) con espigas dentro de los parales F3 del túnel y fije el larguero tallado G2 de túnel a los F3 (cercanos a la torre) utilizando pernos hexagonales de 5/16 x 3-1/4 in. (8 mm x 8,2 cm), arandelas de seguridad con dientes internos y arandelas planas a través de los agujeros de la parte inferior. Luego fije los largueros tallados G1 del túnel a los parales por encima de la pared de rocas, de nuevo utilizando pernos hexagonales de 5/16 x 3-1/4 in. (8 mm x 8,2 cm), arandelas de seguridad con dientes internos y arandelas planas. Ahora utilizando como guía los agujeros en la parte superior de los largueros tallados, con una broca de taladro de 3/16 in. (4,7 mm), perforo los parales F3 y termine de fijar G1 y G2 con tornillos tirafondo de 2-1/2 in. (6,3 cm), arandelas de seguridad con dientes internos y arandelas planas.

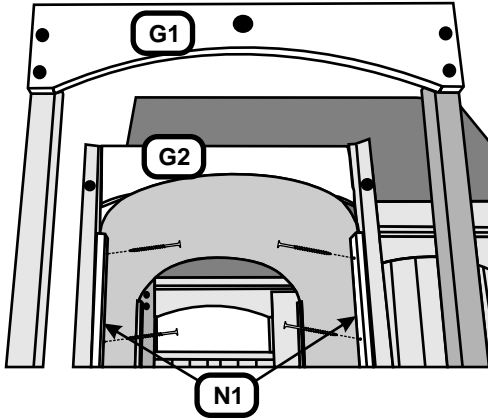
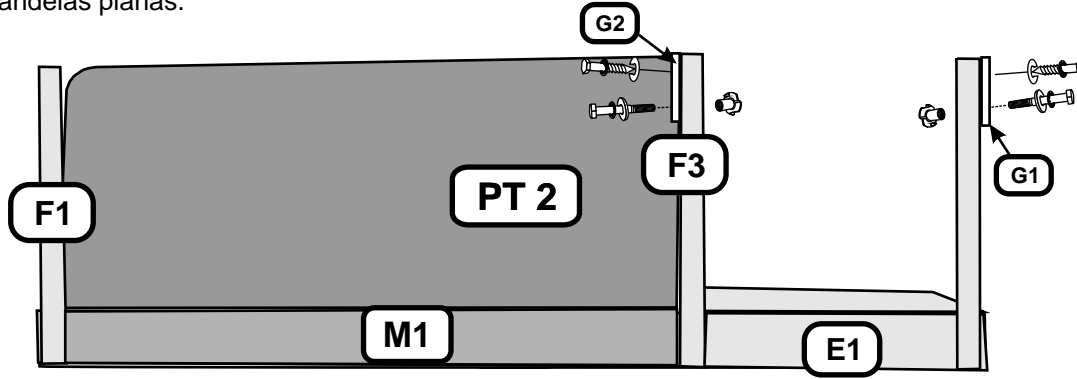

PASO 19

Fije los soportes de túnel con muescas N1 a los parales F1 y F2 en la torre y a los parales F3 hacia la pared de rocas en la parte interna del túnel plástico. Las muescas deberán aparejarse sobre el túnel plástico y fijarse utilizando tornillos para madera de 1-1/2 in. (3,8 cm).

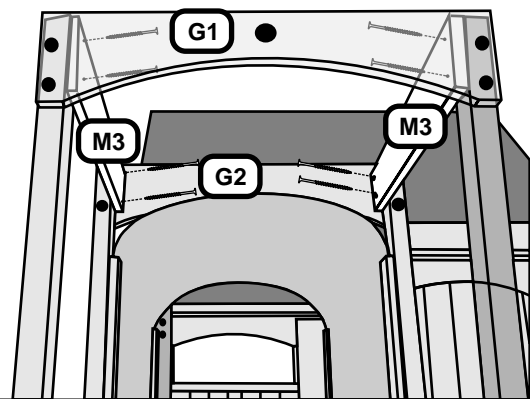
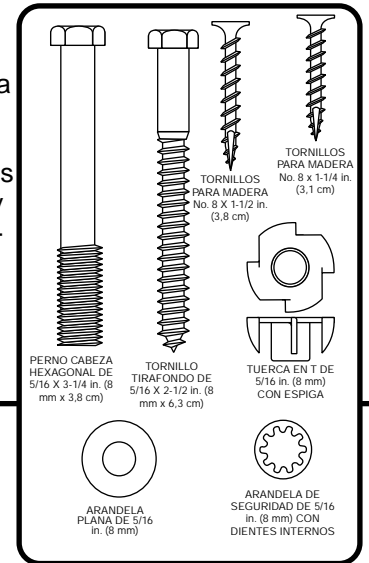

PASO 20

Fije los largueros M3 de pared para el túnel a la parte interior de los parales F3, colocándolos a ras con las partes superiores de los F3 y asegurándolos utilizando tornillos para madera de 1-1/2 in. (3,8 cm). Es posible que necesite un ayudante para empujar los parales juntos de modo que los M3 encajen ajustadamente contra los largueros tallados G2 y G1.

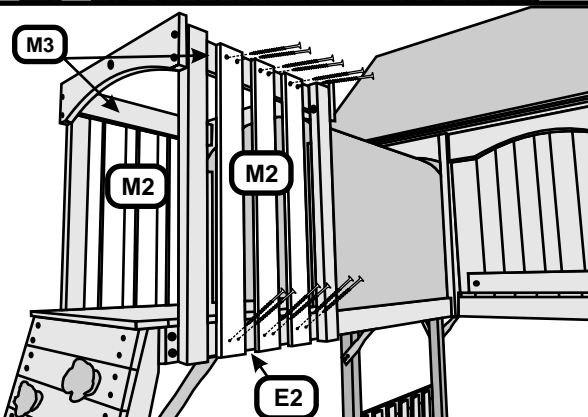

PASO 21

Fije los tableros de pared M2 del túnel, tres por cada lado, en la parte exterior de los M3, largueros izquierdo y derecho E1 y E2 espaciándolos aproximadamente 2 in. (5,1 cm) utilizando tornillos para madera de 1-1/2 in. (3,8 cm) colocándolos a ras de la parte inferior de los largueros E1 y E2 y tornillos para madera de 3,1 cm en la parte superior de M3.

PASO 22

Desde la parte interior del túnel, marque la aproximación de los largueros tallados en la abertura, entrada y salida del túnel y desde el interior utilizando un tornillo con cabeza de arandela de 3/4 in. (1,9 cm), atornille a través del túnel plástico en los largueros tallados.

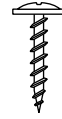

TORNILLO CON
CABEZA DE
ARANDELA No. 8 x 3/4
in. (1,9 cm)

PASO 23

Ahora fije la cuerda a través del larguero tallado superior, haga un nudo. Luego haga cinco nudos más aproximadamente a 18 in. (46 cm) de separación. Luego fije al tablero de pared de rocas inferior halando lo suficiente para que la cuerda no pueda enrollarse una sobre otra y haga un nudo en la parte interior del tablero de rocas inferior.

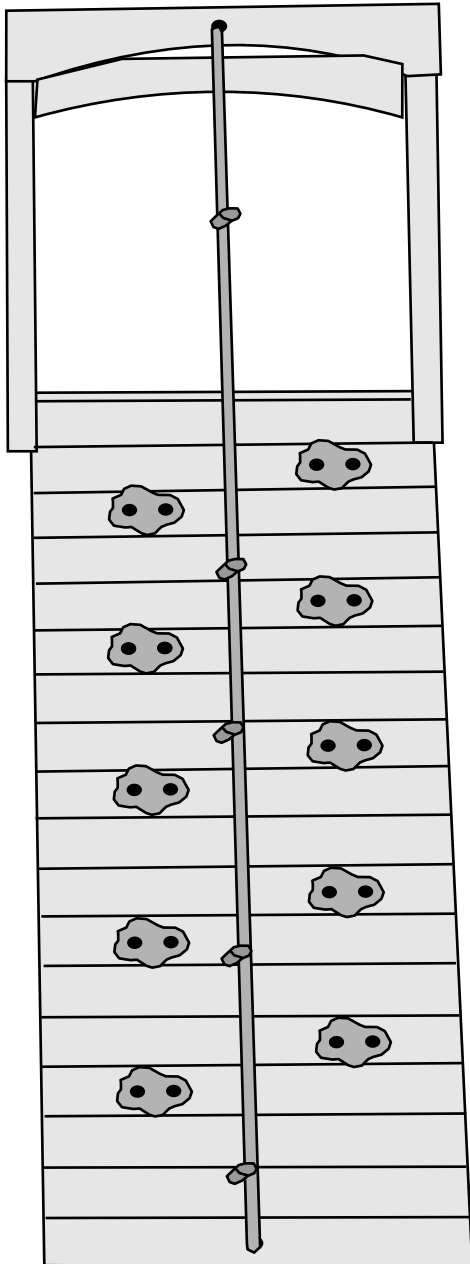

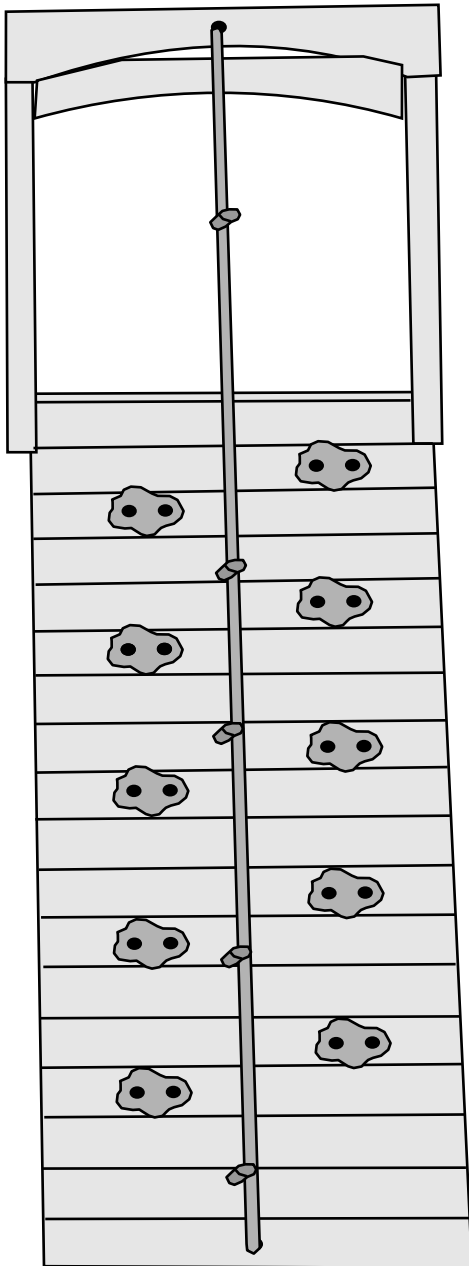

Vista frontal

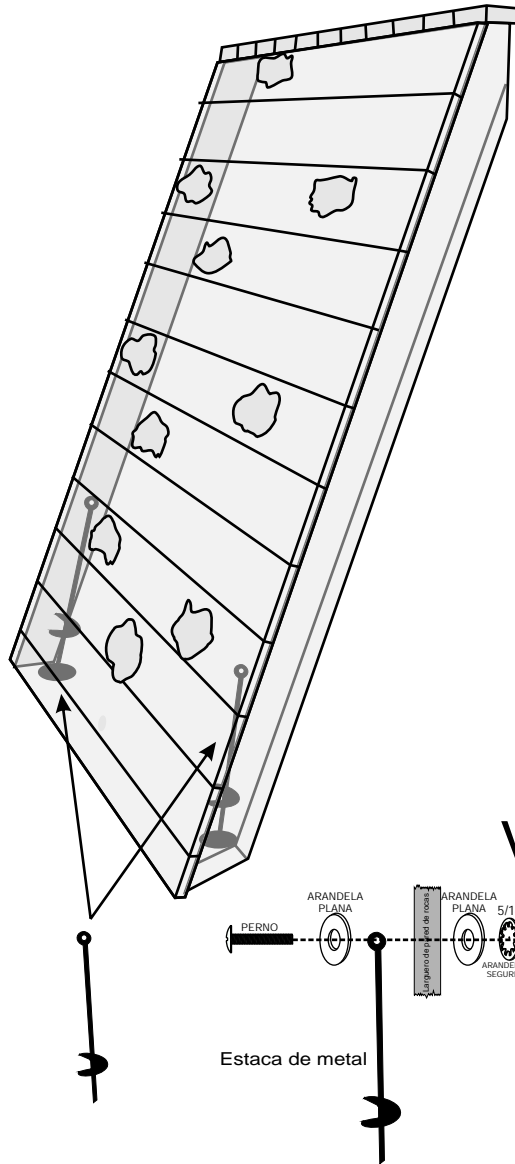

Vista lateral

PASO 24

Ahora es el momento de asegurar la pared de rocas a la tierra utilizando las estacas en las ubicaciones que se ilustran con los círculos negros.

Instalación de las estacas de metal: Necesitará un destornillador largo para apalancar. En algunos casos es necesario cavar un agujero para colocar la estaca y cemento.

Utilice el agujero en la estaca como guía para taladrar un agujero piloto de 3/8 in. (9,5 mm) a través del tablero de base. Utilice un perno Phillips cabeza segmentada, arandela plana de 5/16 in. (8 mm) a través de la estaca en los largueros de la pared de roca, arandela plana de 5/16 in. (8 mm), arandela de seguridad de 5/16 in. (8 mm) en la arandela cilíndrica. Fije al tablero de base.

LEISURE TIME PRODUCTS

P.O. Box 459 • Siloam Springs, AR 72761

Part # 5017

Next Generation

PLASTIC ROOF ASSEMBLY INSTRUCTIONS

H1 Roof Support * 4 Holes * 2 Req
1 x 3-1/2 x 59-1/2 [2.54 x 8.89 x 151.13]

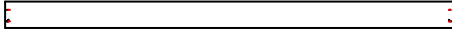

H2 Tent Support * 4 Holes * 1 Req
1 x 3-1/2 x 59-1/2 [2.54 x 8.89 x 151.13]

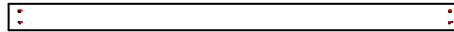

H10 Upright * 2 Holes * 2 Req
1 x 3-1/2 x 29-1/2 [2.54 x 8.89 x 74.93]

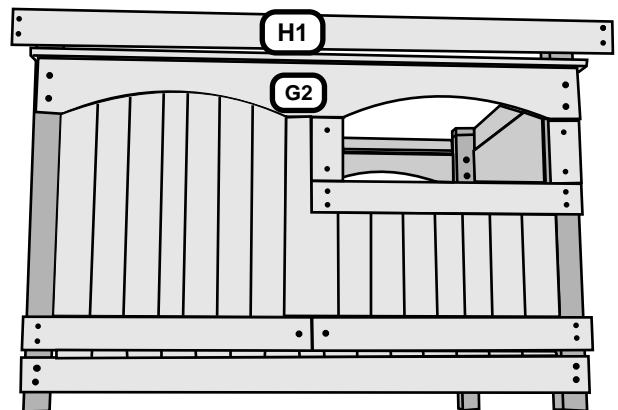
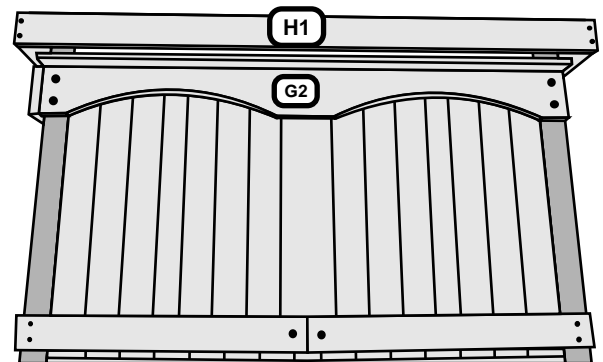
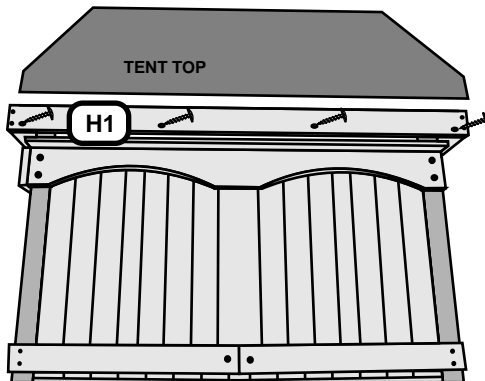
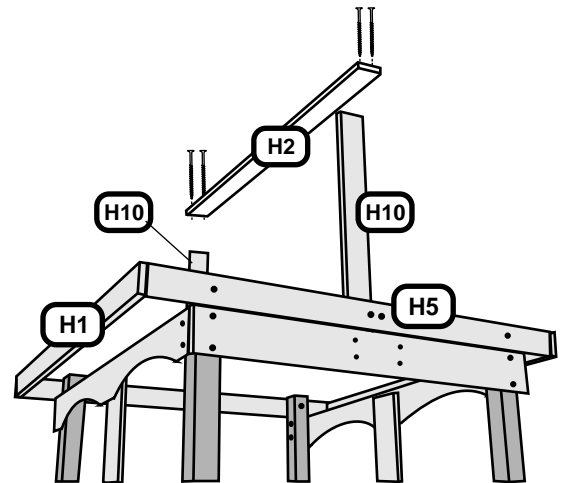
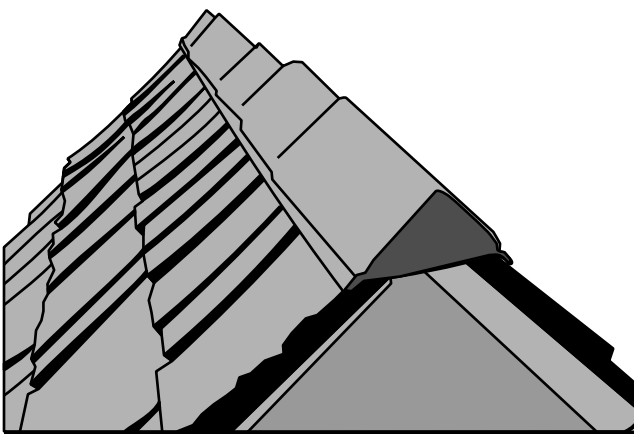
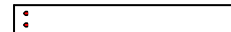

STEP 1

Start by removing Tent Top. Then remove H2 Tent Support and H10 Uprights. Then remove H1 Roof Support Rails from both sides, back and front of set, and you need to mark H1s starting from edge at 1-3/4", 20-1/8", 39-3/8", and 57-3/4". Then put a mark at each of these points; 3/4" down from top of H1 and 1-3/4" down from top of H1. Then using 3/16" pilot drill, drill at these locations.

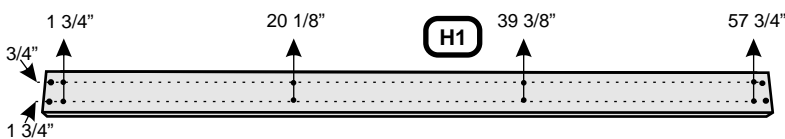

© Copyright Playground Inc

LEISURE TIME PRODUCTS

If you need assistance with parts or have assembly questions, please call Customer Service at 866-362-1123. Our regular office hours are Monday through Friday, 7:00 a.m. to 4:00 p.m. Central Time

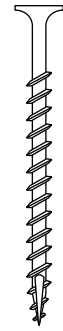
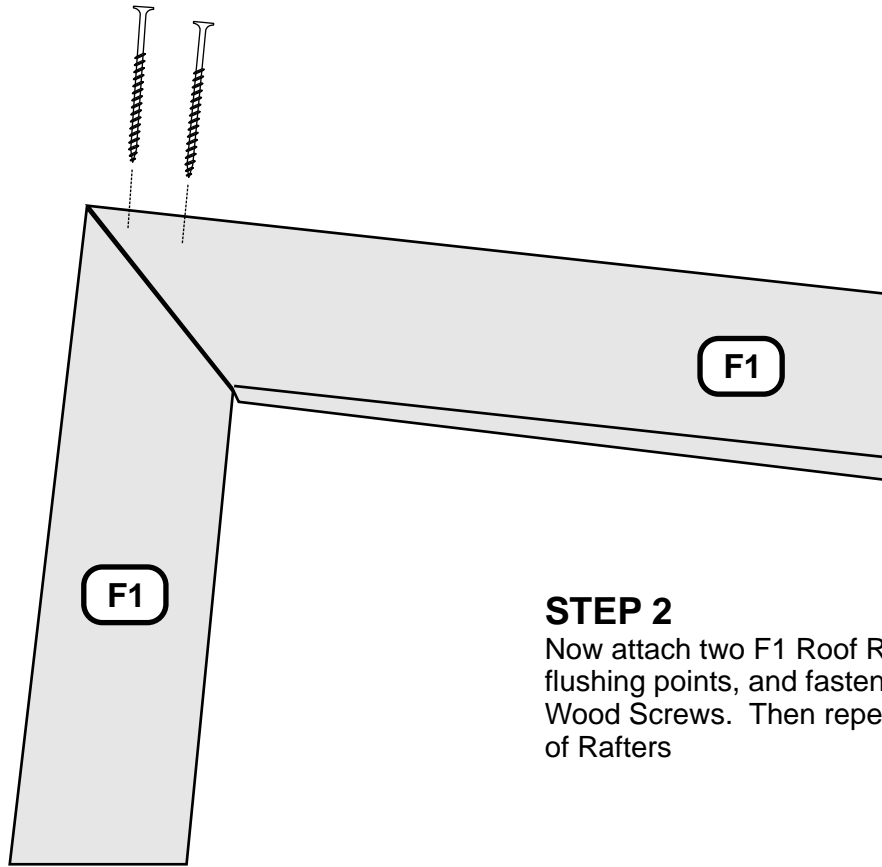

#8 X 2-1/2"
WOOD
SCREW

STEP 2

Now attach two F1 Roof Rafters together, flushing points, and fasten together using 2-1/2" Wood Screws. Then repeat on three more sets of Rafters

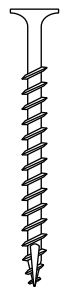
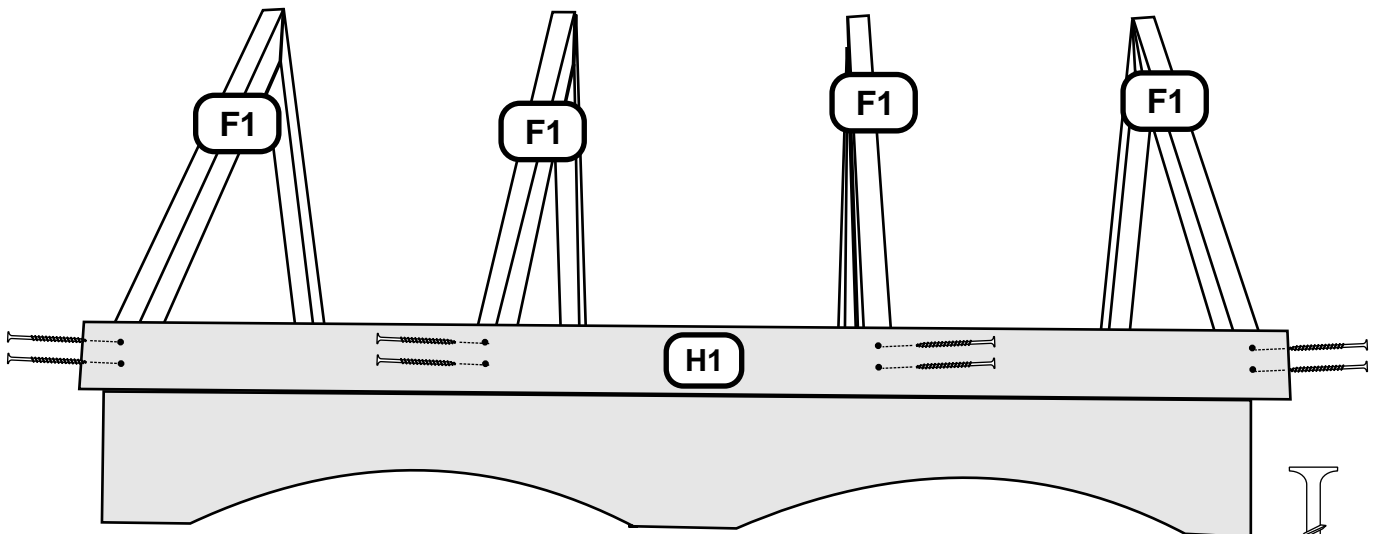

#8 X 2"
WOOD
SCREW

STEP 3

Now replace H1s on Set and note the next process will take at least two people. Starting at either corner, start fastening F1 Rafter Assemblies to H1 using 2" Wood Screws. One person needs to hold as straight up and down as possible and the other person needs to fasten screws into F1 Assemblies.

(R1) Roof Sub Panel

(R2) ROOF PANEL

STEP 4

Now attach White Roof Sub-Panels R1 to F1 Rafter Assemblies overlapping the left and right of Clubhouse approximately 1-1/2". Note: The Sub-Roof Panel will hang down over H1 Roof Rail so that Sub-Roof Panel will be flush at Peak of Roof Assembly. Attach using 3/4" Washer Head Screws, one at the bottom of one of the Center Rafters and one at the top of the other Center Roof Rafter.

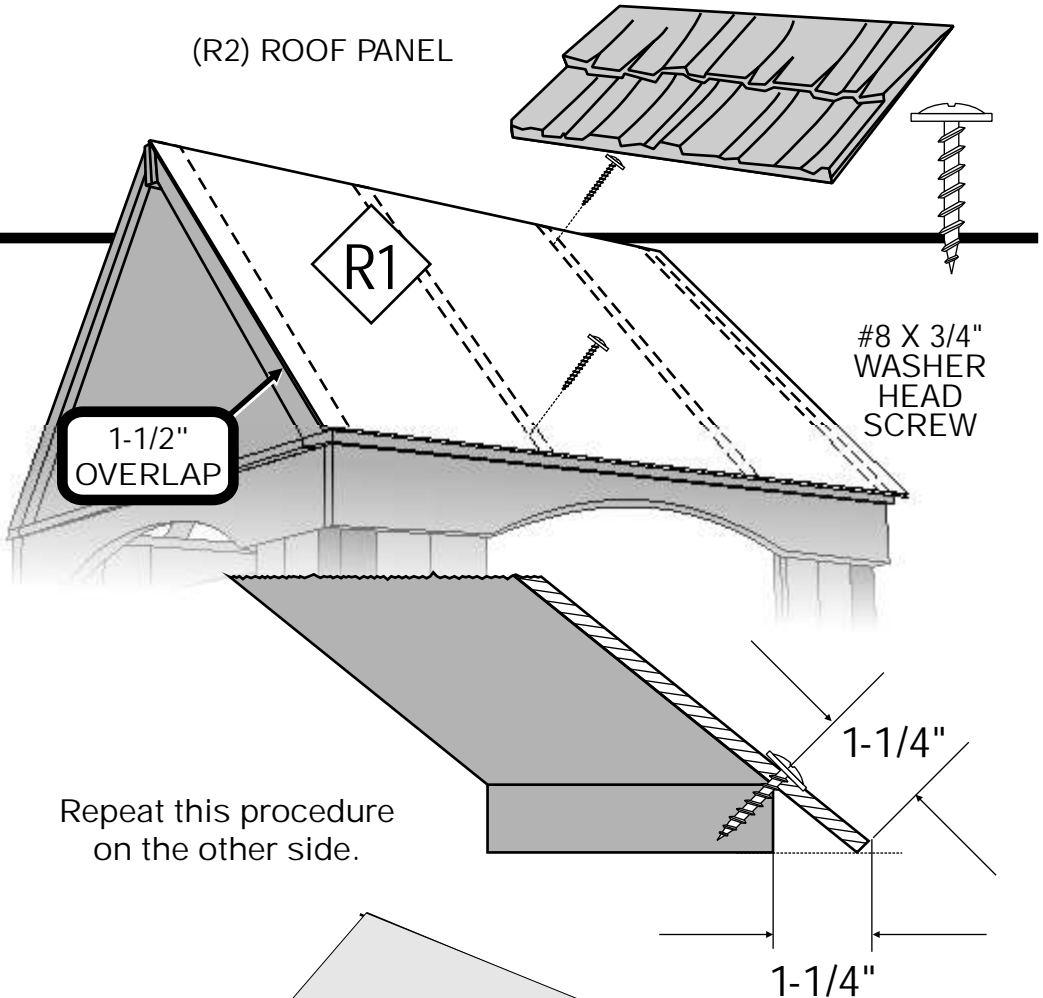

Repeat this procedure on the other side.

STEP 5

Now place Green R2 Roof Panel on top of Sub-Roof Panel and push tight at bottom and edges, up until flush. Now attach to Rafters using 1-1/2" Green Washer Head Screws and Green Washers in pre-drilled holes of R2. You may need to angle screws to hit Rafters. You may also need to pull the Green Panels over the lips of the White Panel to cover them.

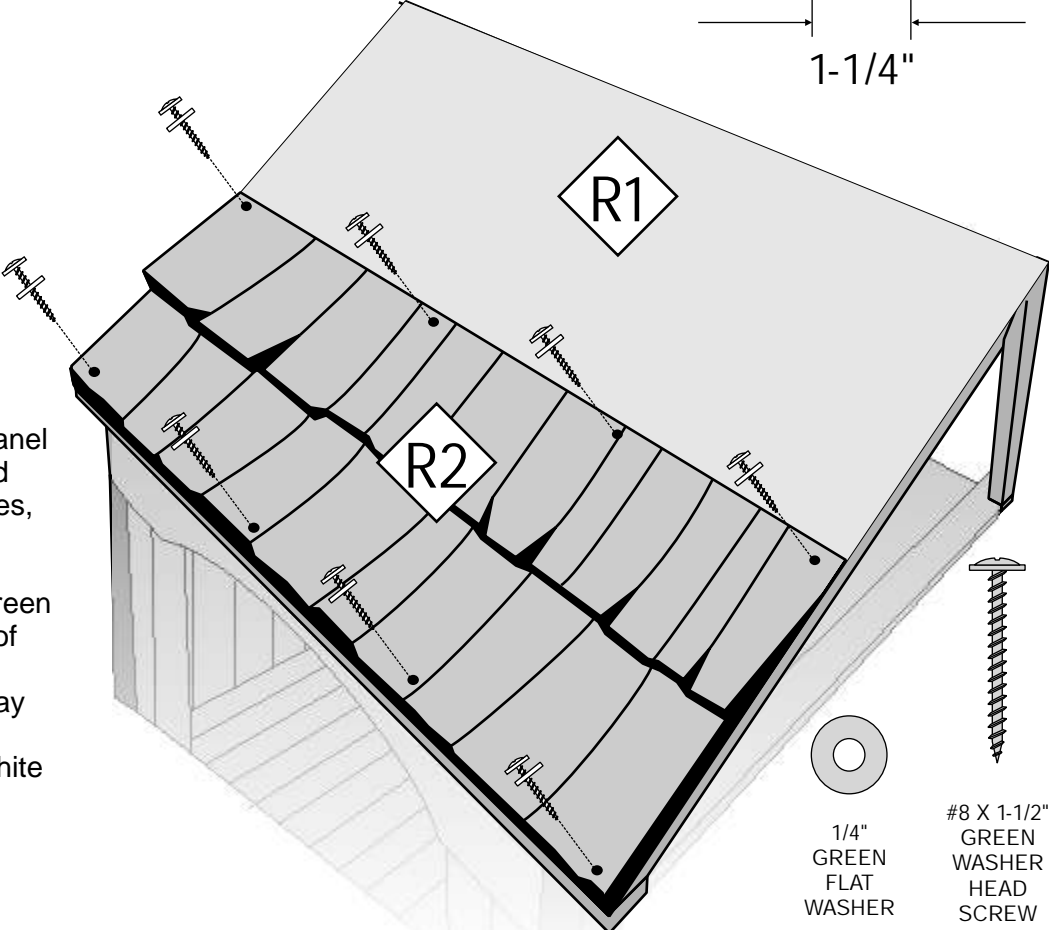

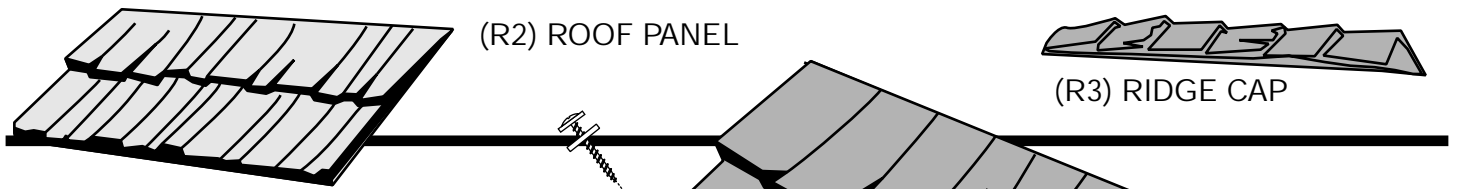

STEP 6

At this point, measure up from bottom 19-1/2" and again attach next panel using 1-1/2" Green Washer Head Screws and Green Washers. Now repeat Green Roof Panels on opposite side of Roof.

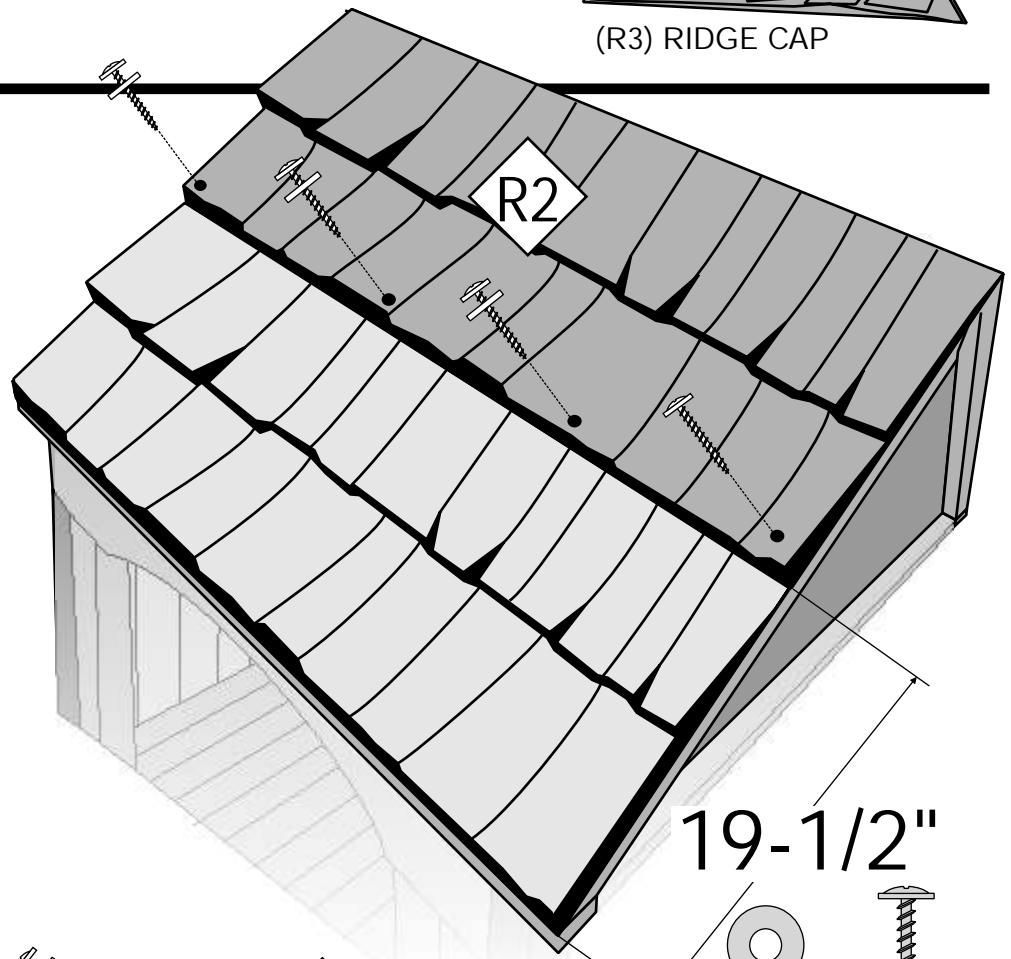

STEP 7

Now place Green Ridge Cap R3 on Peak and center of both sides of Roof. Attach using 1-1/2" Green Screws and Green Washers to Rafters. It may dimple, but you should be able to back out screw a little and straighten.

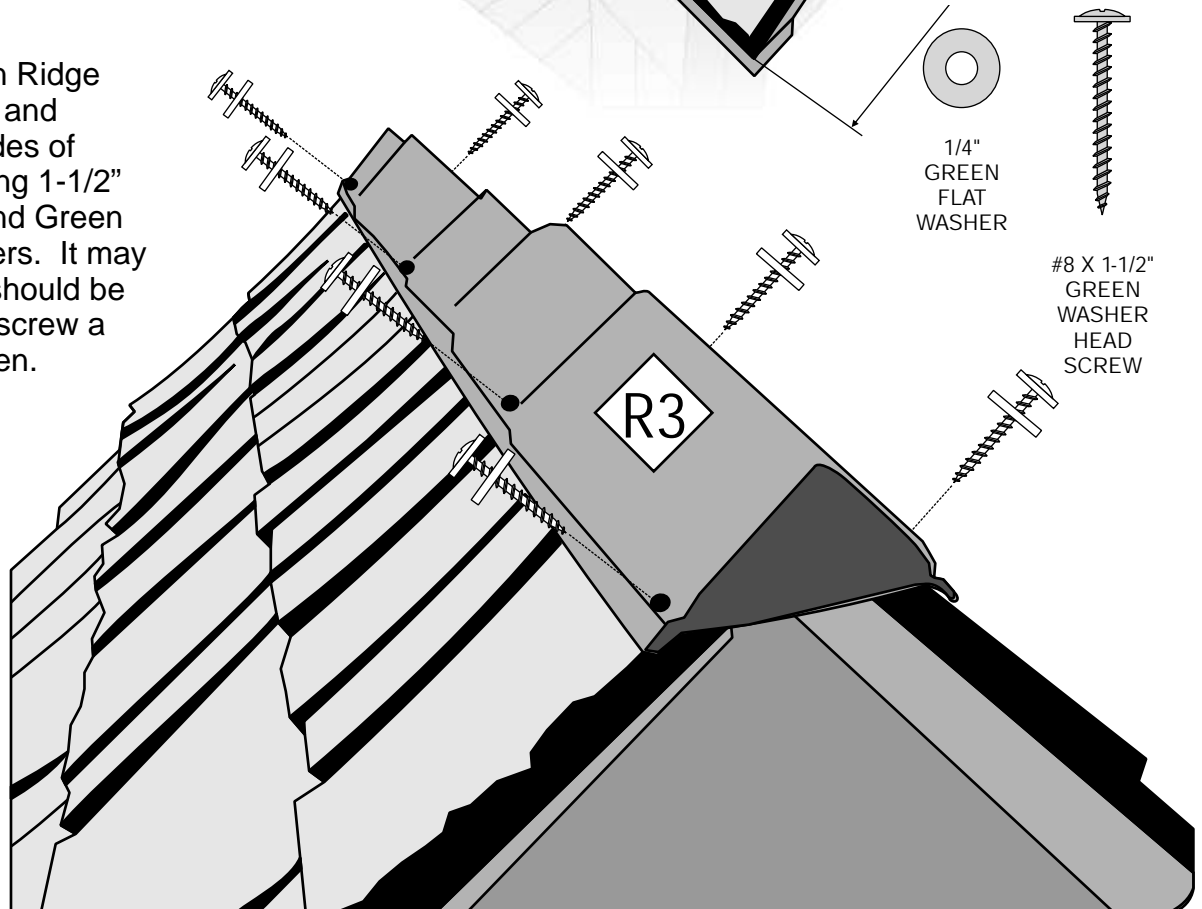

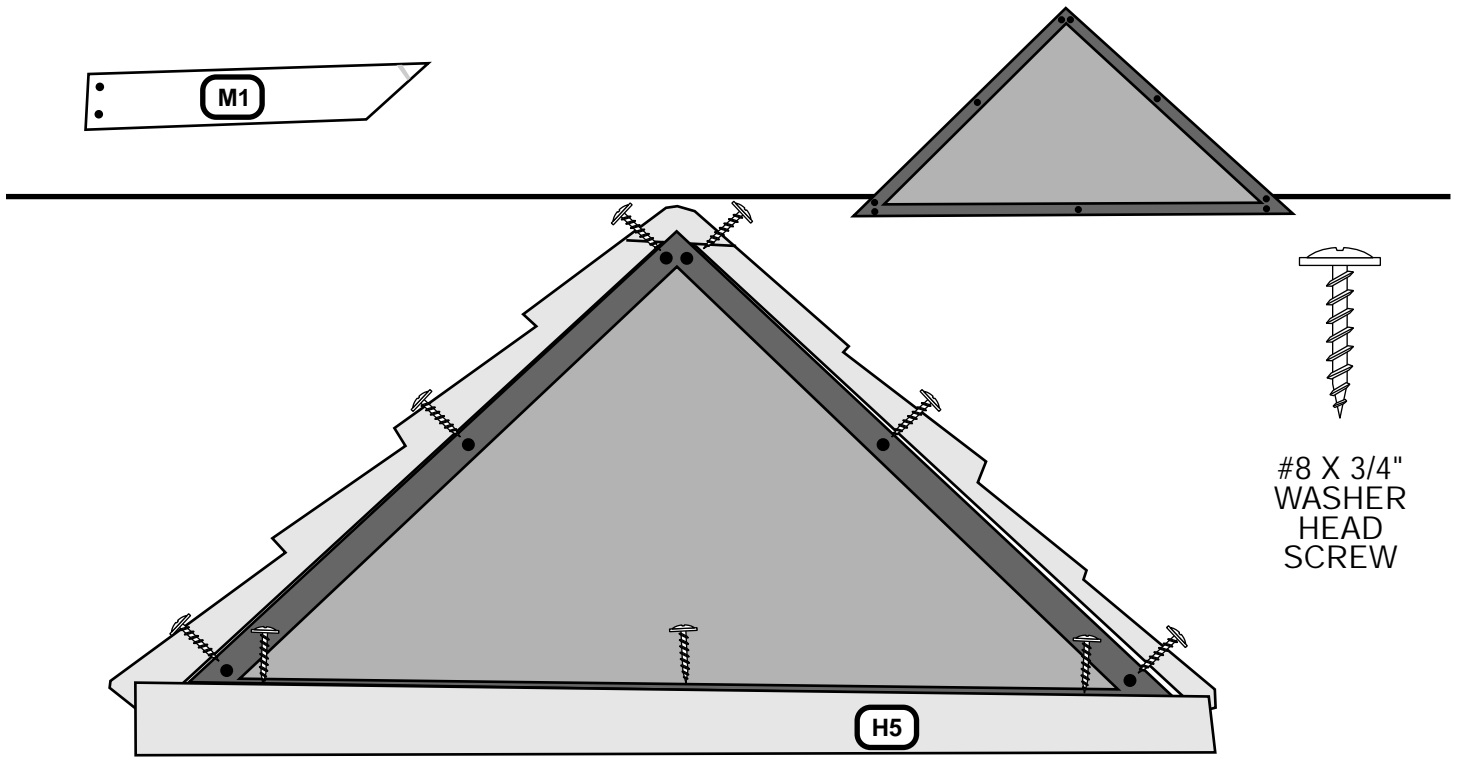

STEP 8

Mesh Panels will be installed using 3/4" Washer Head Screws. It will probably take two people. Start at top. Place two screws and pull evenly down on F1 Rafters and then attach to top of H5 Rail.

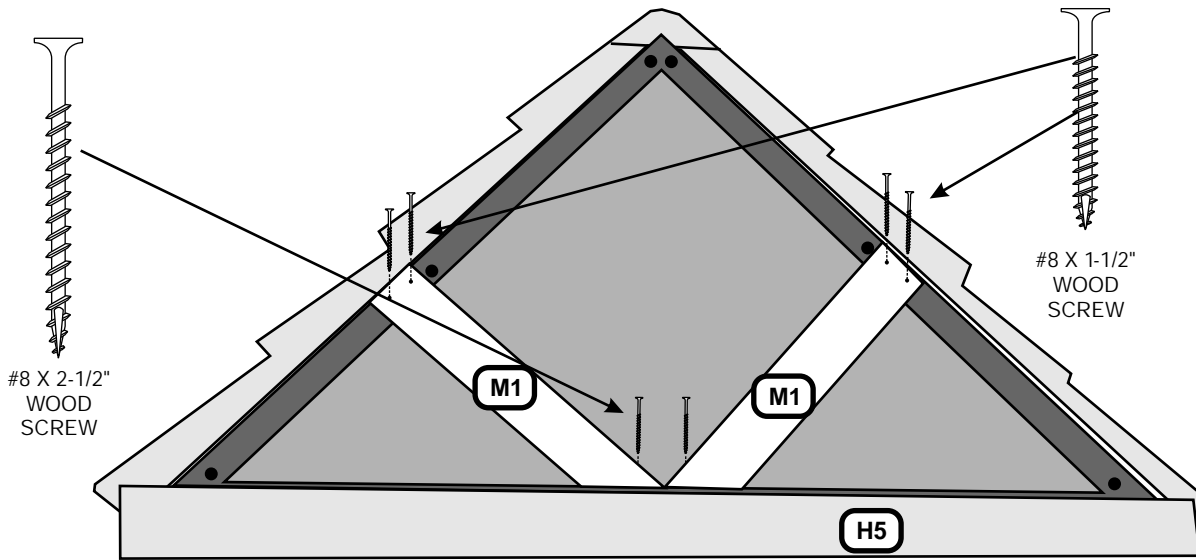

STEP 9

Attach M1 Roof Trim placing 90 degree flat edge pushed towards Sub-Roof Panel until flush and Bottom Angle Panel sitting flat on top of Roof Rail Support and attach at F1 Rafter using 1-1/2 Wood Screws and attach to Roof Rail H5 using 2-1/2" Wood Screws. Repeat Steps 8 & 9 on opposite end.

LEISURE TIME PRODUCTS

P.O. Box 459 • Siloam Springs, AR 72761

Parte # 5017

TECHO PLASTICO

Última Generación

INSTRUCCIONES DE ENSAMBLAJE

H1 soporte del techo * 4 agujeros * 2 Req
1 x 3-1/2 x 59-1/2 [2,54 x 8,89 x 151,13]

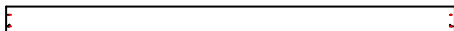

H2 soporte de la cubierta * 4 agujeros * 1 Req
1 x 3-1/2 x 59-1/2 [2,54 x 8,89 x 151,13]

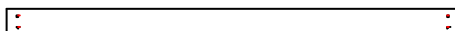

H10 Paral * 2 agujeros * 2 Req
1 x 3-1/2 x 29-1/2 [2,54 x 8,89 x 74,93]

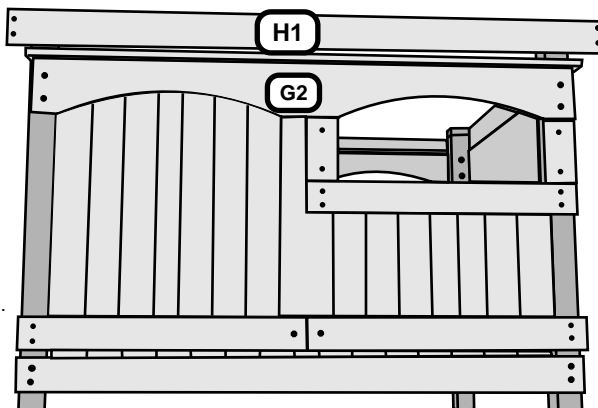
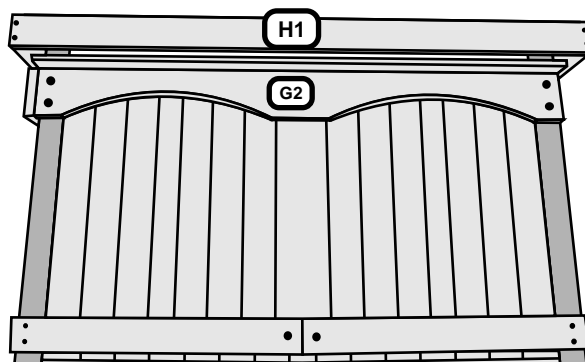
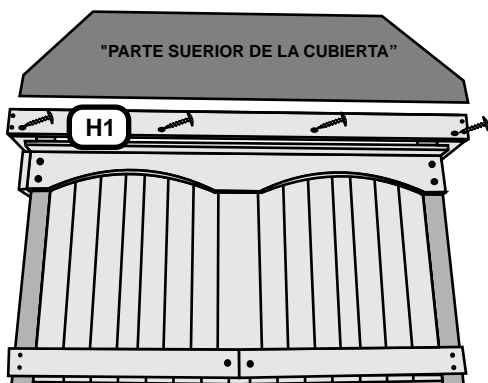
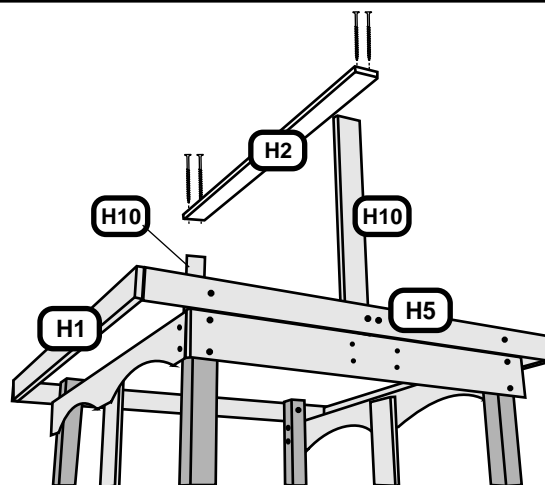
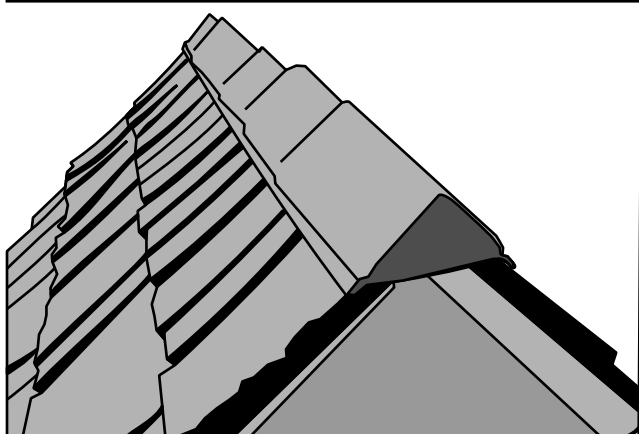
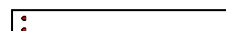

PASO 1

Comience retirando la parte superior de la cubierta. Luego retire el soporte de la cubierta H2 y los parales H10. Luego retire los largueros de soporte del techo H1 de ambos lados, parte posterior y anterior de la unidad y necesita marcar los H1 comenzando desde el extremo a 1-3/4 in., 20-1/8 in., 39-3/8 in., y 57-3/4 in. (4,4 cm; 51,1 cm, 1 m y 1,47 m). Luego coloque una marca en cada uno de estos puntos, 3/4 in. (1,9 cm) hacia abajo desde la parte superior de H1 y 1-3/4 in. (4,4 cm) hacia abajo de la parte superior de H1. Luego utilizando un taladro piloto de 3/16 in. (4,8 mm) taladre en estos puntos.

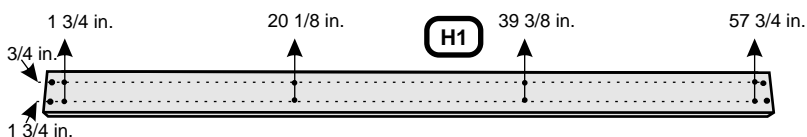

© Copyright Playground Inc

PRODUCTOS LEISURE TIME

Si necesita ayuda con las partes o tiene preguntas sobre el ensamblaje, por favor llame al Dpto. de Servicio al Cliente al 866-362-1123. Nuestras horas regulares de oficina son de lunes a viernes, de 7:00 a.m. a 4:00 p.m. Hora Central.

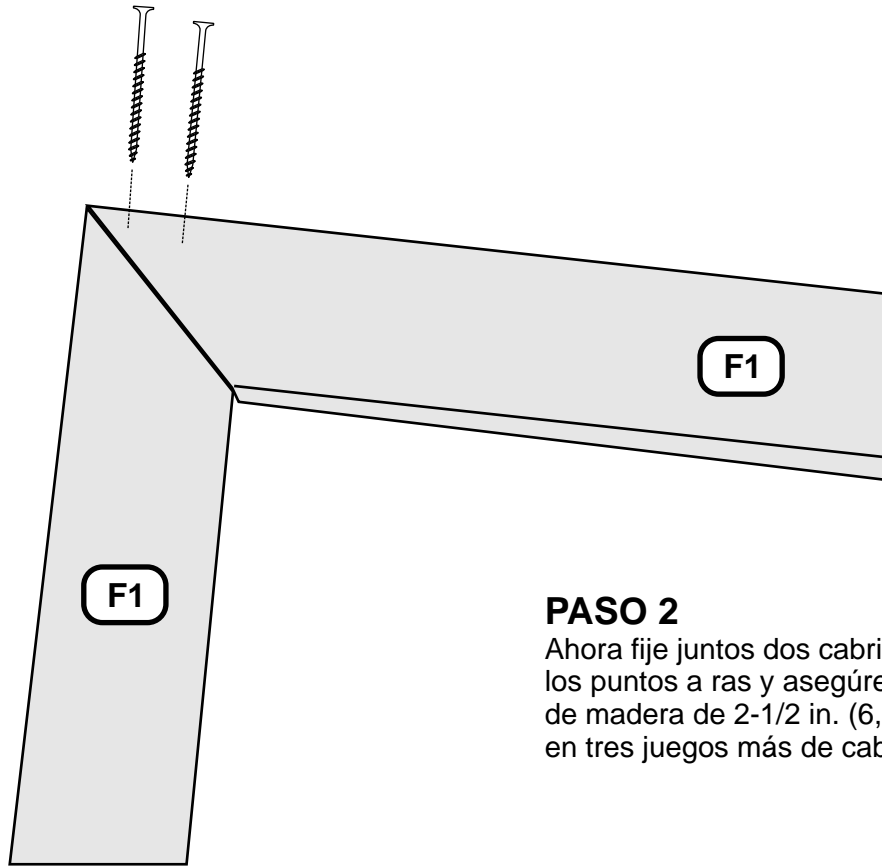

TORNILLOS PARA MADERA
No. 8 x 2-1/2 in. (6,3 cm)

PASO 2

Ahora fije juntos dos cabrios de techo F1, con los puntos a ras y asegúrelos utilizando tornillos de madera de 2-1/2 in. (6,3 cm). Luego repita en tres juegos más de cabrios.

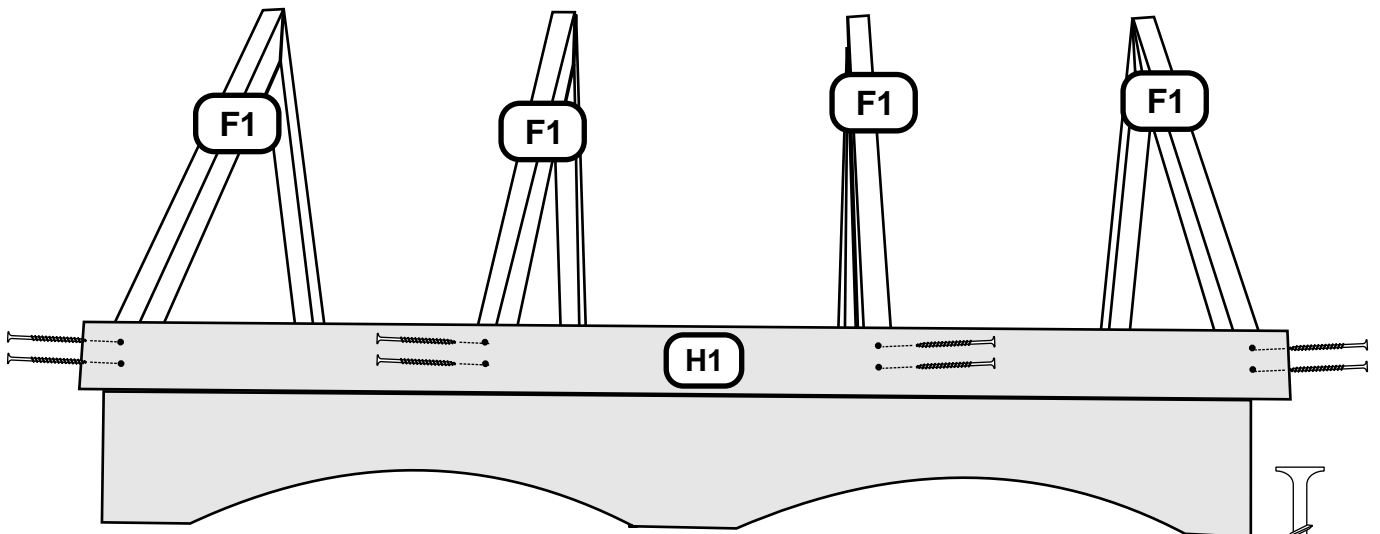

TORNILLOS PARA MADERA
No. 8 x 2 in.
(5,1 cm)

PASO 3

Ahora reemplace los H1 en el juego y observe que el próximo proceso implicará dos personas. Comenzando en cualquier esquina, comience a asegurar los ensambles de los cabrios F1 a H1 utilizando tornillos de madera de 2 in. (5,1 cm). Una persona necesita sostener lo más recto posible hacia arriba y hacia abajo y la otra persona debe asegurar los tornillos a los ensambles de F1.

(R1) Sub Panel del techo

(R2) PANEL DE TECHO

PASO 4

Ahora fije los sub paneles blancos de techo R1 a los ensambles de cabrio F1 superponiendo el izquierdo y el derecho de la casa club aproximadamente 1-3/4 in. (3,8 cm). Nota: El sub panel del techo sobresaldrá hacia abajo sobre el larguero de techo H1 de modo que el sub panel de techo estará a ras en la cima del ensamble del techo. Fije utilizando tornillos con cabeza de arandela, uno en la parte inferior de uno de los cabrios centrales y otro en la parte superior de otro cabrio central de techo.

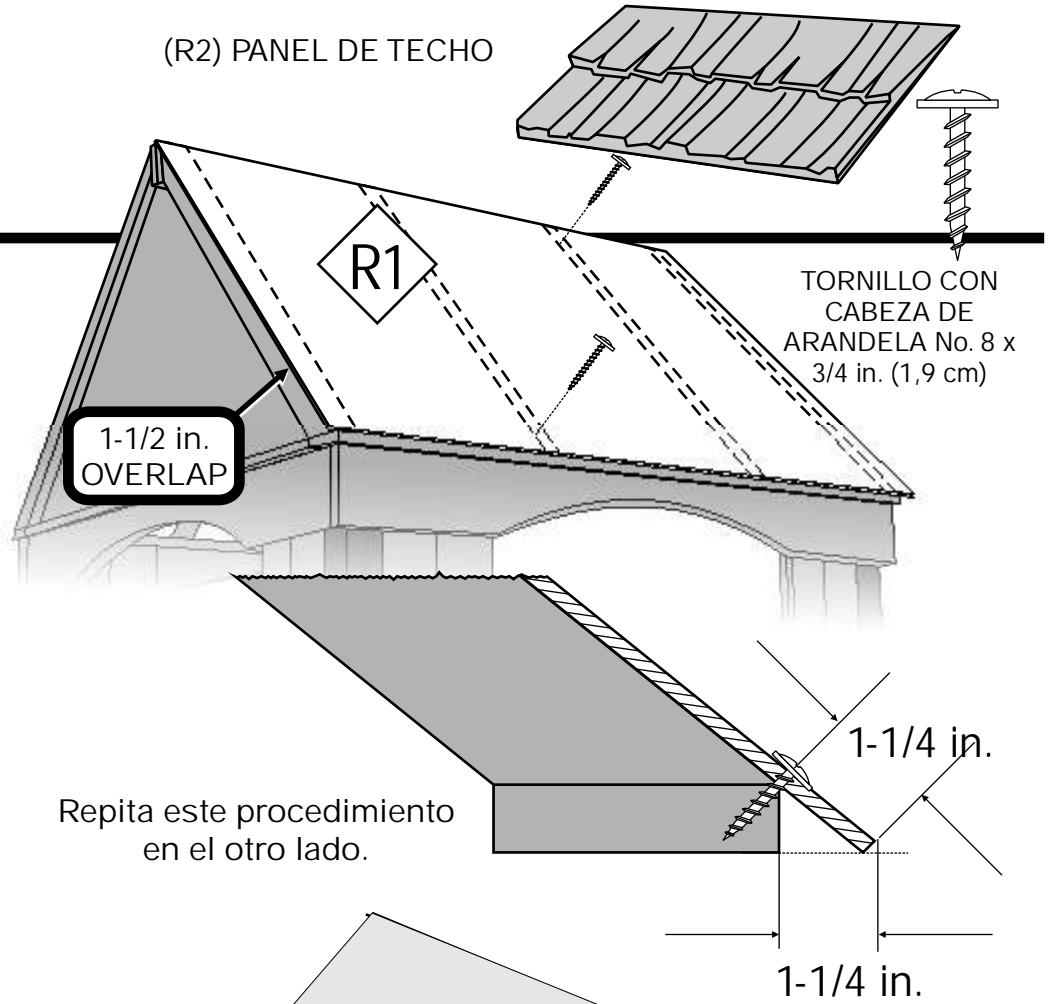

PASO 5

Ahora coloque el panel verde de techo R2 en la parte superior del sub panel de techo y presione firmemente en la parte inferior y los bordes hasta que quede a ras. Ahora fije a los cabrios utilizando tornillos verdes con cabeza de arandela de 1-1/2 in. (3,8 cm) y arandelas verdes en los agujeros pre-taladrados de R2. Es posible que necesite inclinar los tornillos para alcanzar los cabrios. Es posible que también deba halar los paneles verdes sobre los rebordes del panel blanco para cubrirlos.

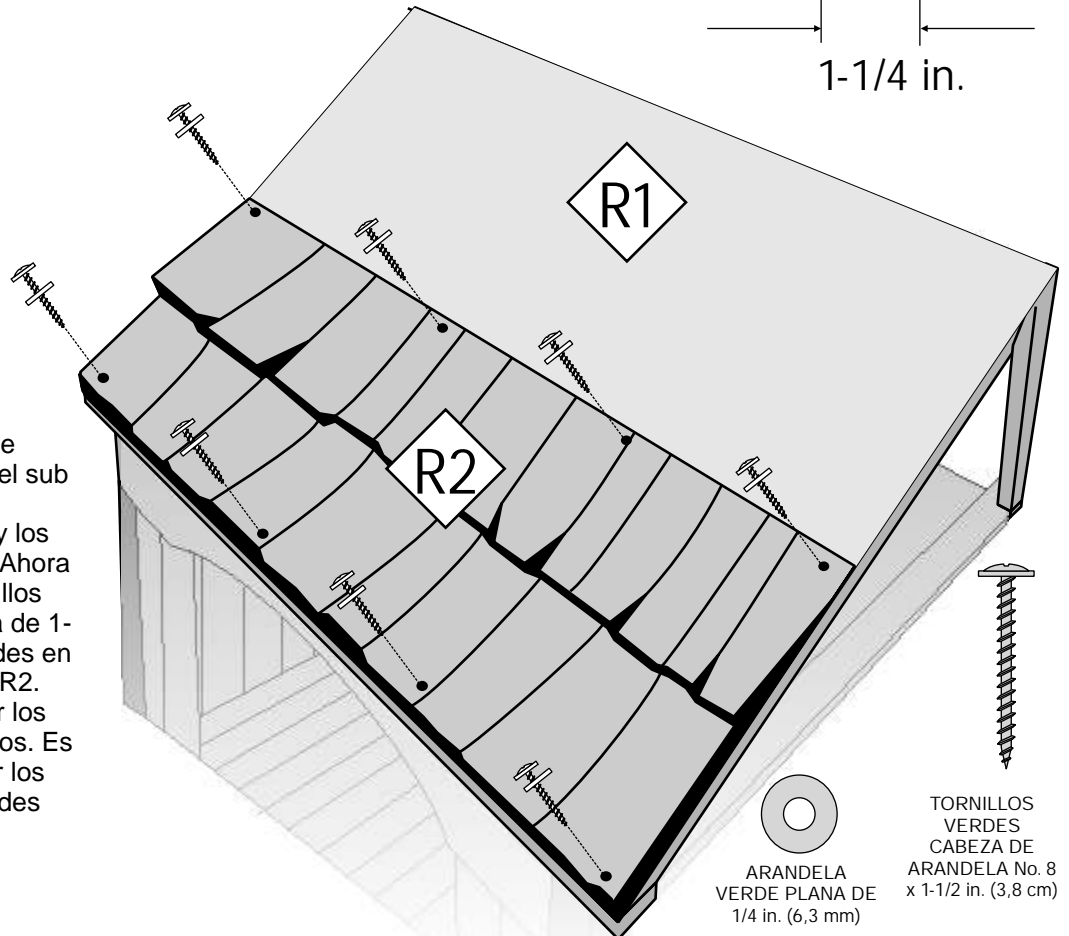

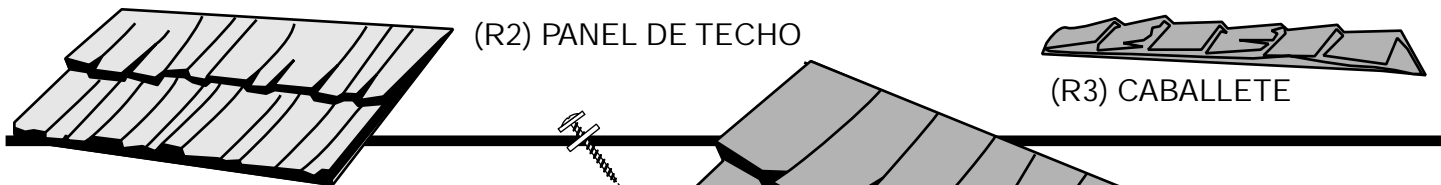

PASO 6

En este punto mida desde la parte inferior hacia arriba 19-1/2 in. (49,5 cm) y de nuevo fije el siguiente panel utilizando tornillos verdes cabeza de arandela de 1-1/2 in. (3,8 cm) y arandelas verdes. Ahora repita los paneles verdes de techo en el lado opuesto del tejado.

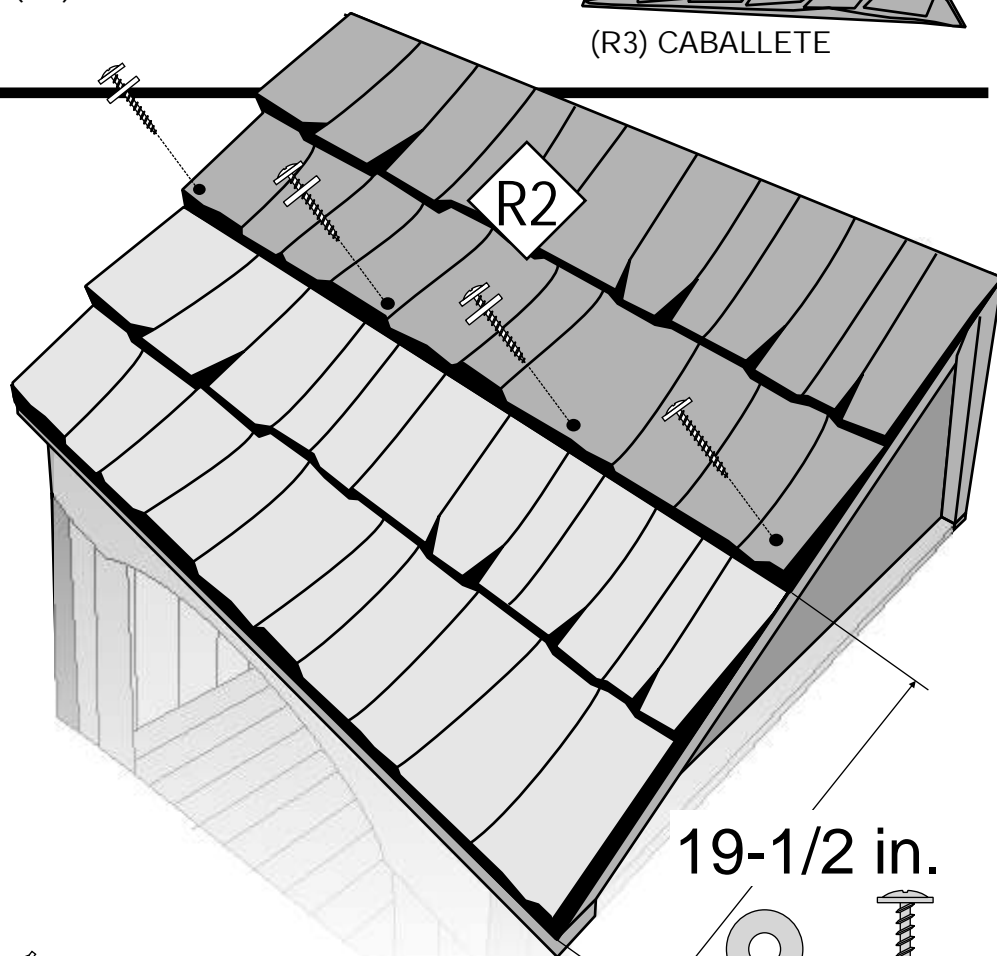

PASO 7

Coloque R3, el caballete verde, en la cima y al centro de ambos lados del techo. Fije utilizando tornillos verdes de 1-1/2 in. (3,8 cm) y arandelas verdes a los cabrios. Puede formarse una hendidura pero debería poder sacar un poco el tornillo y enderezarlo.

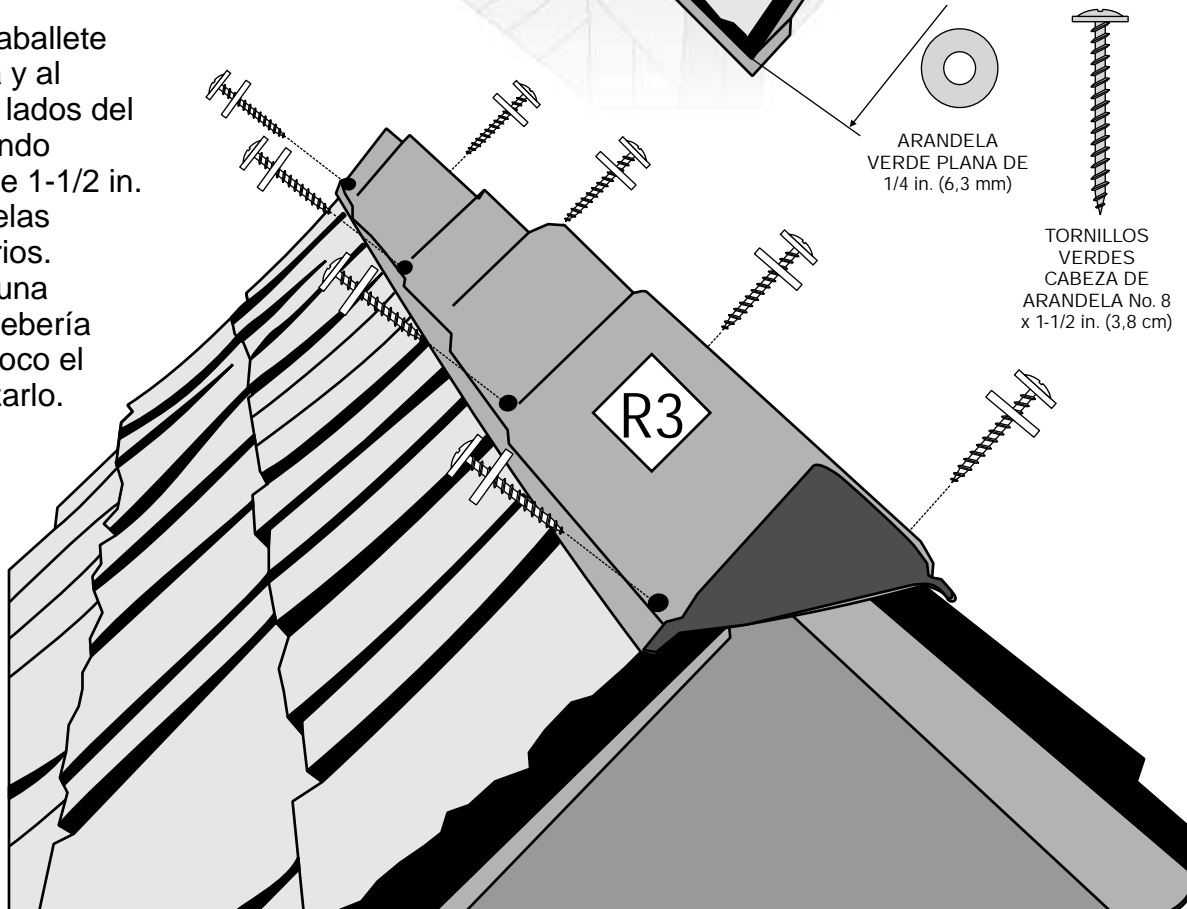

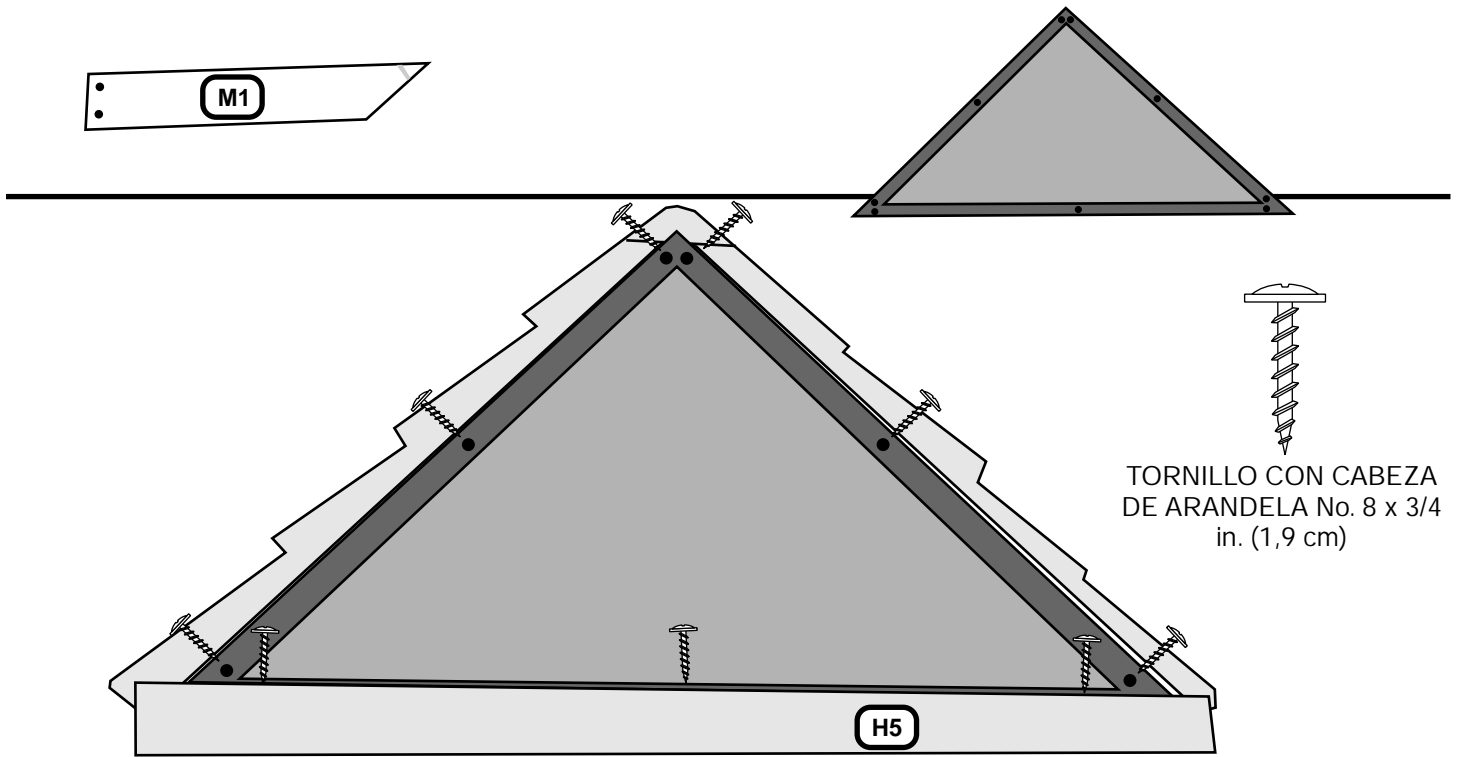

PASO 8

Los paneles de malla se instalarán utilizando tornillos cabeza de arandela de 3/4 in. (1,9 cm). Probablemente se necesitarán dos personas. Comience en la parte superior. Coloque dos tornillos y hale uniformemente hacia abajo en los cabrios F1 y luego fije a la parte superior del larguero H5.

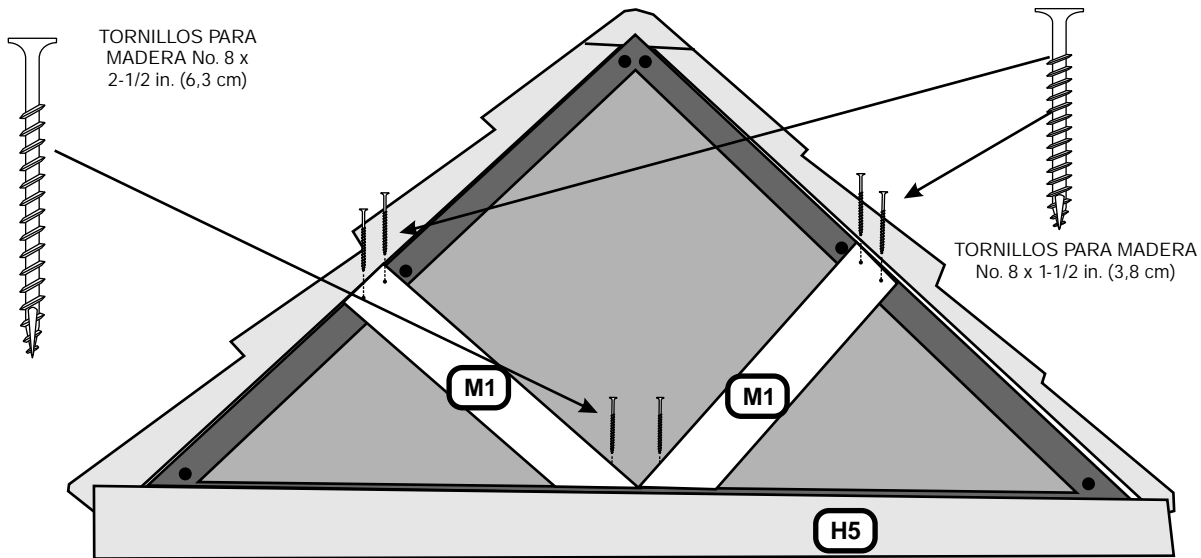

PASO 9

Fije las riostras del techo M1 colocando el extremo plano a 90 grados presionado hacia el sub panel del techo hasta que quede a ras y el panel de ángulo inferior colocado plano sobre el soporte del larguero del techo y fije en el cabrio F1 utilizando tornillos para madera de 1-1/2 in. (3,8 cm) y fije al larguero del techo H5 utilizando tornillos para madera de 2-1/2 (6,3 cm). Repita los pasos 8 y 9 en el extremo opuesto.