



Installation Data

Bathtubs

Fax-On-Demand # 1901

NOTICE: Please inspect the unit thoroughly before installation to make sure it has not been damaged during transportation.

If you have any questions please call LASCO Bathware's Technical Services Department at 800-877-2005.

IMPORTANT! Before installation begins:

- READ ALL INSTALLATION INSTRUCTIONS COMPLETELY. IMPROPER INSTALLATION WILL VOID THE WARRANTY.**
- Make sure that walls and floors meet fire safety requirements of local building code and/or FHA/HUD Minimum Property Standards.
- The wood blocks attached underneath the bottom of the bath fixture units are for storing and shipping. These blocks need not touch the sub-floor. It is common in the industry to set foundation materials underneath the bottoms of tub and shower units with casting plaster/plaster of paris.
NOTE: Finished alcove must have interior dimensions, shown on product technical data sheet rough-in diagrams, to properly install unit.
- For three wall alcove installations, use only integral molded three-sided tiling flange bathtubs.
- LASCO Bathware does not recommend utilizing bathtubs without an integral tiling flange in an alcove installation where a shower head would be installed above the unit and utilized as a shower.

Pre Installation Requirements

- In remodeling, if necessary, add studs at each end to provide a vertical nailing surface for the side nailing flanges of bath fixture product.
- To avoid obstruction during installation make sure that supply lines, spout pipe and valve plumbing do not project into alcove.
- Tubs require a 6" x 12" (150mm x 305mm) floor opening for the 1" (40mm) drain, waste and overflow (DWO) kit. [See Diagram 1]
NOTE: Be sure floor opening location matches bath fixture drain location.
- Use of casting plaster/plaster of paris (foundation material) is recommended in all commercial structures (i.e. hotels, motels, dormitories, health clubs, etc.).

Installation

If mounting fittings on tubs, from stable reference points (back wall studs, floor) measure the locations of spout and valves. Note measurements here:

Tub Filler: _____ Valve: _____

- Make sure framed-in alcove is of proper size per LASCO dimensions, square, and plumb; check floor for levelness.
- Place the tub in the alcove with the front skirt firmly on the floor. **The bathtub should be set level.** To check, use a level on top of the ledges on both ends of tub and on top of dam. [See Diagram 2]
- After leveling tub, mark each stud (or concrete or block wall) immediately above the back horizontal flange. Remove tub from alcove.
- Measure the distance between the top of the back horizontal flange and the bottom of the tub ledge (approximately 1½" (40mm)). Carefully mark this dimension on the back studs (or wall), below the first mark. [See Diagram 3: Detail A]
- Ledger Strip: LASCO mandates the use of supports under the rear ledges of bathtubs to prevent shifting. Use horizontal ledger strip along the entire rear ledge or "I" or "T" supports in at least two places in vertical position. Nail a 1" x 3" x 60" (25mm x 75mm x 1525mm) ledger strip immediately below the lower marks made on framing.
NOTE: Fasteners: To wood framing - 1" (25mm) galvanized roofing nails or 1" (25mm) pan head screws; to steel studs - drill flanges and studs with 3/16" (5mm) carbide bit and fasten with #10 x 1" (25mm) sheet metal screws with washers; to concrete/block walls use 1" (25mm) concrete nails with nailing tool or impactor. **NOTE:** Pre drilling nailing flanges is recommended to avoid cracking the unit.
- Bottom support materials: Casting plaster/plaster of paris (herein referred as foundation materials) are not necessary but its use is highly recommended for a firmer bottom support. When using foundation materials, the following applies:
In a bucket, mix foundation material. Place a large mound of plaster on the subfloor, in the approximate location of the tub bottom center. The mounds should be placed high enough so that when the tub is set, it will cause the plaster to displace and spread.
- Replace unit into alcove with front skirt firmly on floor. Make certain that back ledge of tub rests firmly on ledger supports [See Diagram 3: Detail A]. Level unit, shim ledger, if necessary. **The bathtub should be set level.**
- a. Spot-fasten the two bottom corners and the two top corners of the vertical side nailing flanges.
b. Nail fasten at each stud through the topside flanges; through the back flange, at each stud (concrete; 16" (405mm) on center), working from both ends toward back center.
c. Complete the fastening through vertical side flange, approximately 8" (205mm) on center.
- When other than cementitious backer board plaster is to be used, furring strips as thick as nailing flanges are recommended for installation on studs above the installed LASCO unit to assure walls will be flush. 100% silicone sealant with mildew resistant properties should be applied between the backer board and horizontal surface of unit. Then finished wall materials can be applied [See Diagram 4: Detail A]. Finishing of other trades should be done in conformance with applicable codes and generally accepted building practices.
- Tub - Mounted Fittings: Refer to dimensions noted above; mark fitting locations. Using a hole saw (fine tooth or abrasive grit cutting edge),

make necessary openings for filler and valves, drilling from inside (smooth side) out.

- Door Enclosures: Use LASCO shower door model for an engineered fit. Reference the Complete Works Catalog or the LASCO Bathware website for the shower door installation guide.

NOTE: Where local codes specify minimum door openings, shower stalls may require swing (not sliding) doors.

Clean-up

CAUTION: DO NOT USE heat, or solvent based cleaning fluids

NOTE: Do not remove adhered label. Warranty/User Maintenance Label must be left for occupant. (Required by ANSI Z124).

1. To prevent staining and/or blistering: Remove all construction debris before filling product for plumbing inspection. Drain and wipe clean immediately after the inspection process. Use sponge with warm water and liquid detergent. Do not use abrasive cleaners, such as scouring powders or pads, steel wool, scrapers, sandpapers or anything else that may scratch, mar or dull the finish. Roofing tar or paints may be removed with turpentine, rubbing alcohol or paint thinner (not lacquer thinner).
2. Plaster may be removed by scraping with the edge of a piece of wood or rigid plastic. Do not use a metal scraper or utensil to remove plaster or paint from finish.
3. Dulled areas can be restored to a high gloss with white or cream-colored automotive rubbing compound, followed by application of a coat of good quality white automotive polish (or similar) and buff with a soft cloth.
4. Remove minor scratches with 600 grit wet/dry sandpaper, followed by Step #3 (above).
5. Major gouges require professional repair.

User Maintenance Instructions

IMPORTANT! Use only recommended cleaners and procedures described herein. Use of other materials and methods may damage your bath fixture and void the warranty.

- For normal cleaning: Never use abrasive cleaners such as scouring powders or pads, steel wool, scrapers, sandpaper or anything else that could scratch or dull the surface of your LASCO unit. Instead, use warm water and liquid detergents or non-abrasive cleansers, especially those bathroom cleaners recommended for cleaning fiberglass.
- To keep your LASCO bath fixture sparkling clean: Apply a coat of good quality automotive paste wax or polish and buff to a high shine with a soft cloth or towel. Repeat every six months for easier cleaning and long lasting protection.
NOTE: DO NOT WAX standing surfaces of the unit bottom (this includes textured, slip resistant standing surfaces), which could result in greater risk of slipping and personal injury.
- To restore a scratched or dull unit: Use an automotive polishing compound applied with a clean cotton rag. Rub scratches and dull areas vigorously. Wipe off residues. Follow with automotive wax treatment described above.
- To remove adhesive: Try 3-M Natural Cleaner, De-Solv-It or similar materials. If residues remain, saturate a small, white, cotton rag with nail polish remover (naphtha or acetone) and rub vigorously until the adhesive dissolves and disappears. These solvents are highly flammable and must be used sparingly and with caution. Do not smoke or permit others to do so. Make sure all nearby heating devices (including pilot lights) are extinguished. Do not allow solvent to go down the drain. Make sure not to contact plastic drain grates or other synthetic materials.
- Rubber Mats: If you use a rubber "anti-skid" mat, make sure to remove it from the unit after each use to avoid harm to the surface finish.
- Hard Water: Water in certain regions, if not wiped up after bathing/showering, may cause fading of some bath fixture colors. This is a natural occurrence beyond LASCO's control. (See Warranty)

CAUTION: When using any cleaning or polishing materials, make sure to read and follow all package instructions carefully. Wear rubber gloves at all times and avoid contact with eyes, skin, clothing, rugs and furnishings. Make sure all residues are rinsed off thoroughly.

Diagrams

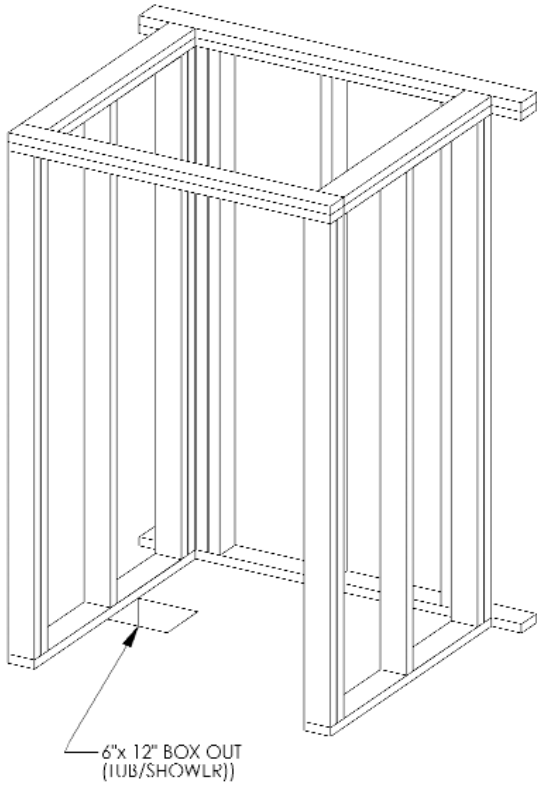

Diagram 1

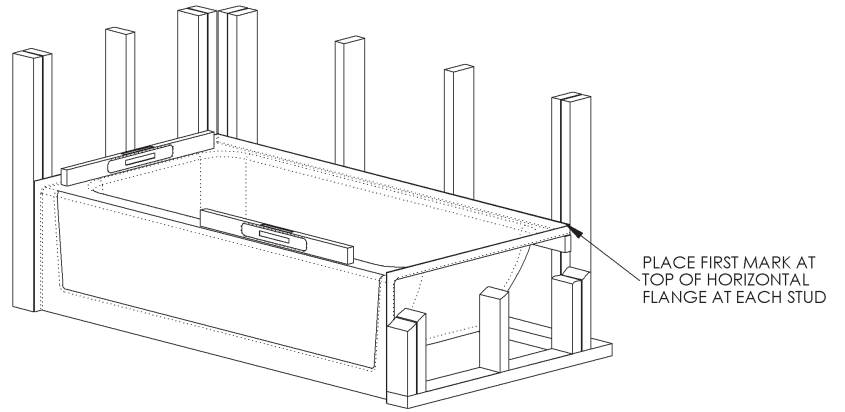

Diagram 2

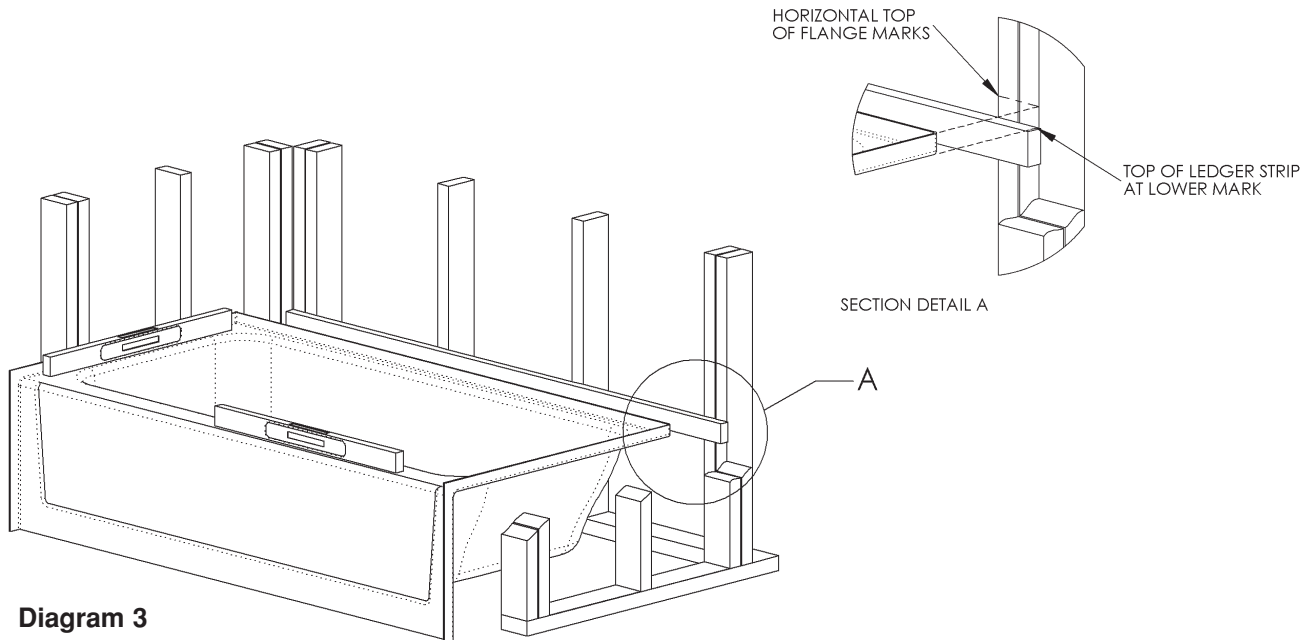

Diagram 3

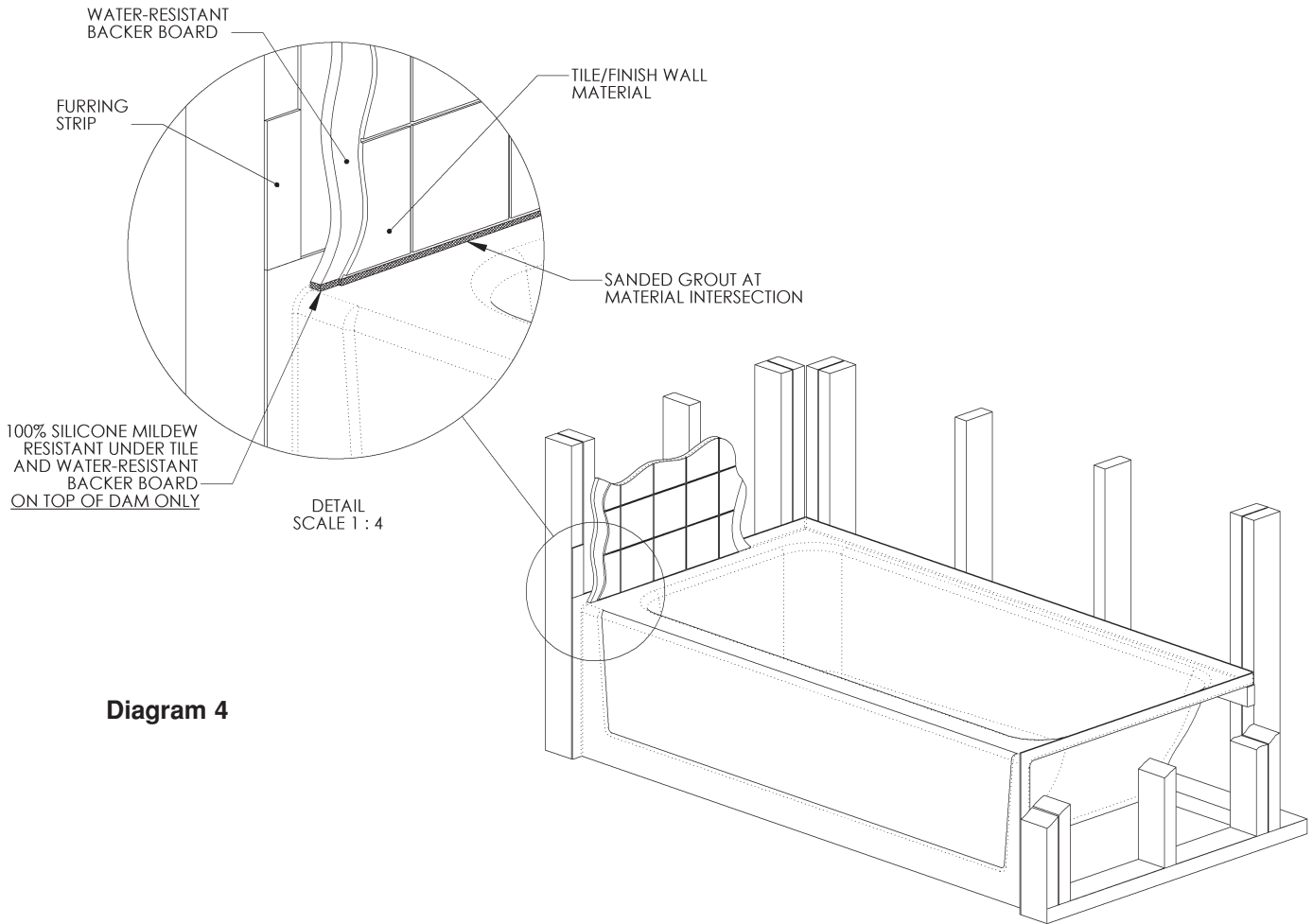

Diagram 4

Field Service/Repairs

West Central
P.O. Box 310
Moapa, NV 89025
PH: 800-335-5151, 702-864-2100
FAX: 800-799-2158

North East
40 Industrial Road
Conewago Industrial Park
Elizabethtown, PA 17022
PH: 800-444-0781
FAX: 717-367-4722

Mid-Atlantic
P.O. Box 1177
Halifax County Ind'l Pk.
So. Boston, VA 24592
PH: 800-444-0832
FAX: 434-572-1794

South East
210 S. Harris St.
Cordele, GA 31015
PH: 800-444-0926
FAX: 229-273-6838

North Central
888 W. Broadway
Three Rivers, MI 49093
PH: 800-444-1426
FAX: 269-273-3053

South West/South Central
151 Industrial St.
Lancaster, TX 75134
PH: 800-876-3044
FAX: 972-227-0769

West
3261 E. Miraloma Ave.
Anaheim, CA 92806
PH: 800-877-0464, 714-961-9735
FAX: 800-328-6465

Rocky Mtn./North West
801 Northern Pacific
Yelm, WA 98597
PH: 800-444-5126
FAX: 360-458-3024

Customer Service/ Sales Order

Customer Service/Sales Order
C/O Skymark Tower
1521 No. Cooper, Ste. 500
Arlington, TX 76011
PH: 800-945-2726, 817-801-8300
FAX: 866-544-5353

Technical Services Department
8101 E. Kaiser Blvd.
Anaheim, CA 92808
PH: 800-877-2005, 714-993-1220