

12200A-LED

2" LED NEW CONSTRUCTION HOUSING

DIMENSIONS

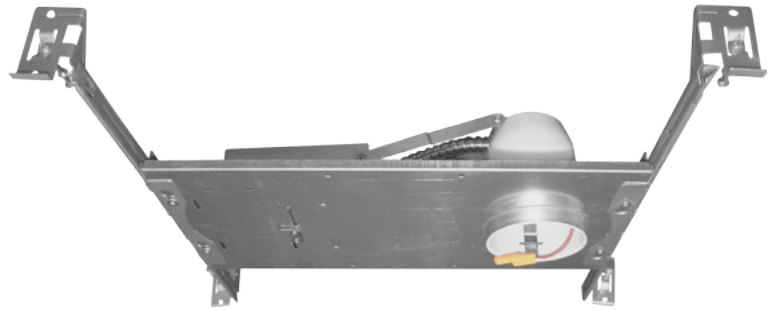
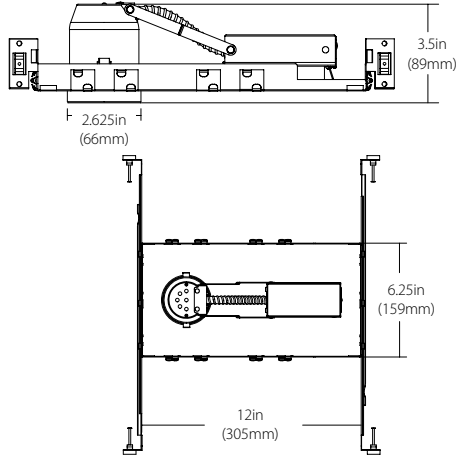

The 12200A-LED is designed with high efficiency LED drivers and has IDEAL connections that allows for quick, snap-in connection of NICOR® 2" D-series LED downlights. Suitable for new construction in residential and commercial applications.

FEATURES

- UL Listed
- Easy installation for new construction projects
- Allows for quick, snap-in connection of 2" D-Series downlights
- Rated for use in damp locations
- 3 1/2" height allows use in 2" x 6" joist construction
- Heavy-gauge NICOR captive hanger bars provide greater stability, allowing housing to be positioned at any point within a 24" joist span, then locked in place with set screws
- Unique hanger bar lip design helps align can to joist
- Four double-headed captive nails provide for ease of installation
- Score lines allow bars to be shortened without tools to accommodate a 12" joist span

ORDERING INFORMATION

Catalog Number	Description
12200A-LED	2" LED New Construction Housing

