

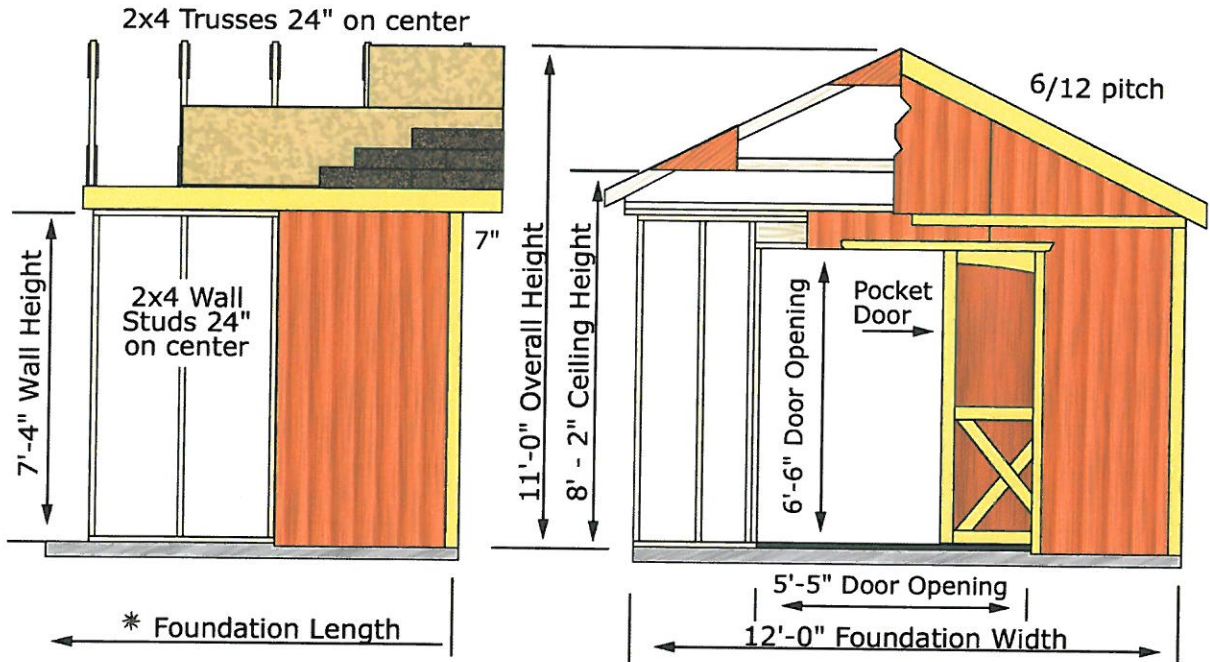

Before you order our kit or begin construction, obtain a building permit. If additional documents are required contact Richard@barnkits.com.

DAKOTA ELEVATION



* Foundation length is the same as building length. *Example*; 16' building length = 16'=0" foundation.

Wall Framing: Constructed from 2x4 pre-cut wall studs spaced 24" on center between top, bottom and tie plates.

Pocket Doors: Pre-built 2x4 frame covered with LP 'Smart Panel' primed siding. White pine trim, *not painted*, installed over siding.

Siding: Louisiana-Pacific 'Smart Panel' primed 8" o.c. groove with 50 year warranty, 5 year labor replacement

Roof System: 2x4 trusses spaced 24" on center, (40 psf ground snow load, 90 mph wind load). 7/16" OSB roof sheathing. *Shingles by owner.*

Exterior Trim: White pine trim for corners, door, gable trim and front and sidewall fascia.

Hardware: Nails for all framing, metal hurricane hangers for trusses. Heavy duty aluminum track, decorative door handles and lockable door latch.

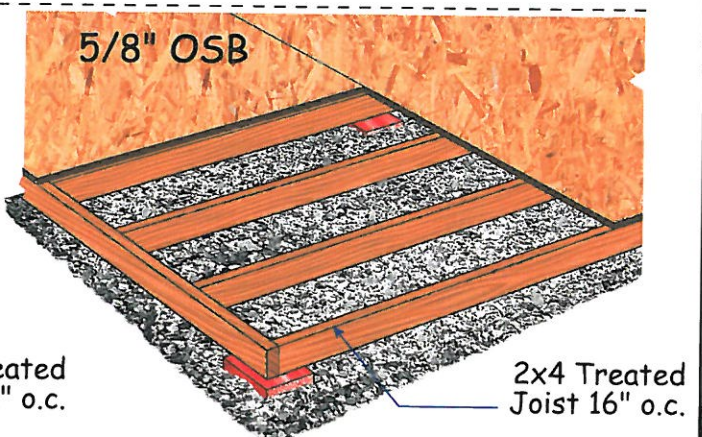
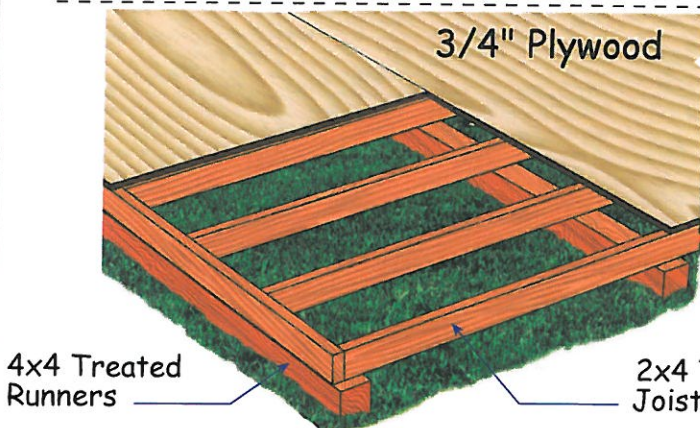

Deluxe Floor: 4x4 treated runners can be installed directly on the grass. The runners elevate the floor providing air flow under the floor eliminating moisture. 8' and 10' wide floors have three runners, 12' wide floor have four. The floor covering is 3/4" plywood.

Standard Floor: This floor system is best installed over an existing foundation, cement slab, blacktop or gravel base. Bricks or patio stones can be used to level the 2x4 frame. The floor covering is 5/8" OSB (oriented strand board).



12300 Ford Rd
Suite 110
Dallas, TX, 75234
1-800-521-3245
fax 972-888-9966

www.eaglemetal.com

To Whom It May Concern:

The attached truss design drawings referenced below have been prepared by me or under my direct supervision based on the design parameters provided by **Reynolds Building Systems** and are assumed to be in accordance with the appropriate building code.

Any changes to these parameters and/or information provided on the original truss drawing voids the affected sealed truss drawing and new information shall be submitted to this office for additional review.

Listed below are the truss designs included in this package and covered by this seal.
Job Name: **RBS JRENAOLD R14C WA 1.pdf** - 1008223
R14R

Please refer to individual truss designs for specific loading and design criteria.

11/05/2009

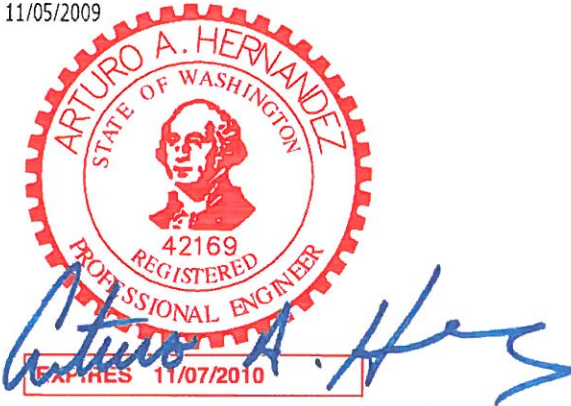

Arturo A. Hernandez
(WA, 42169)

My license renewal date for the state of WA is 11-07-2010

The seal on these drawings indicates acceptance of professional engineering responsibility solely for the truss components shown. It is the responsibility of the building designer as to the suitability for use of each truss listed above.

SPAN 7-4-12	PITCH 5.921 /12	QTY 1	OHL 2-3-10	OHR 2-3-10	CANT L 0-0-0	CANT R 0-0-0	PLYS 1	SPACING 24 in	WGT/PLY 23 lbs
----------------	--------------------	----------	---------------	---------------	-----------------	-----------------	-----------	------------------	-------------------

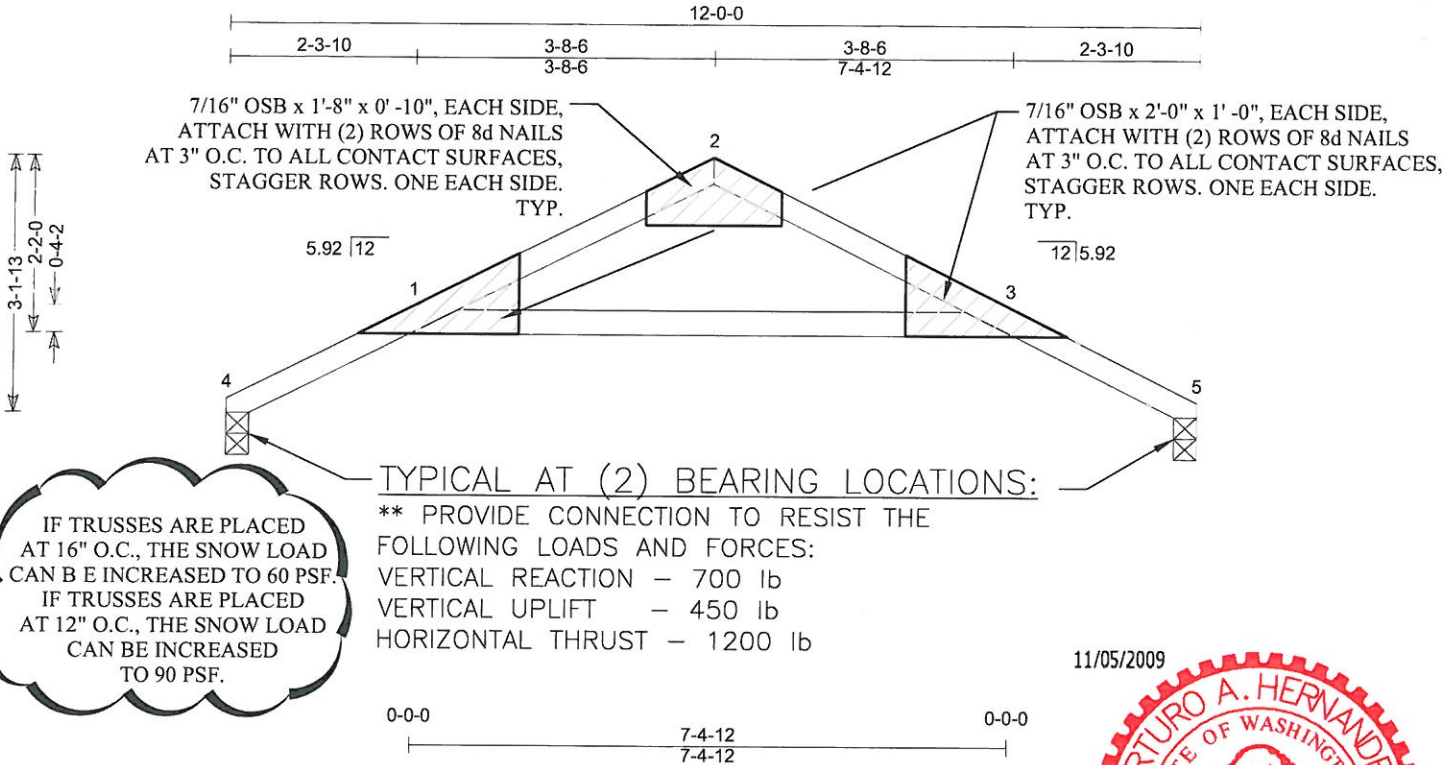

IF TRUSSES ARE PLACED AT 16" O.C., THE SNOW LOAD CAN BE INCREASED TO 60 PSF.
IF TRUSSES ARE PLACED AT 12" O.C., THE SNOW LOAD CAN BE INCREASED TO 90 PSF.

TYPICAL AT (2) BEARING LOCATIONS:
** PROVIDE CONNECTION TO RESIST THE FOLLOWING LOADS AND FORCES:
VERTICAL REACTION - 700 lb
VERTICAL UPLIFT - 450 lb
HORIZONTAL THRUST - 1200 lb

11/05/2009



Loading	General	CSI Summary	Deflection	L/	(loc)	Al
Load (psf)	Bldg Code: IBC 2003/ TPI 1-2002	TC: 0.87 (1-2) BC: 0.60 (3-1) Web: 0.00 (1)	Vert TL: 0.21 in Vert LL: 0.02 in Horz TL: 0 in	L/663 L/999	(3-1) (3-1)	L/ L/
TCLL: 40	Rep Mbr Increase No					
TCDD: 7	D.O.L.: 115%					
BCLL: 0						
BCDL: 10						

Reaction Summary						
JT	Type	Brg Combo	Brg Width	Rqd Brg Width	Max React	Max Grav Uplift
4	Pin (Wall)	1	3.313 in	1.50 in	698 lbs	-147 lbs
5	Pin (Wall)	1	3.313 in	1.50 in	698 lbs	-147 lbs

Material Summary		Bracing Summary	
TC	SPF #2 2 x 4	TC Bracing:	Sheathed or Purlins at 3-5-0, Purlin design by Others.
BC	SPF #2 2 x 4	BC Bracing:	Sheathed or Purlins at 5-4-0, Purlin design by Others.
Webs			

Loads Summary

- This truss has been designed for the effects of wind loads in accordance with ASCE7 - 02 with the following user defined input: 90 mph, Exposure C, Enclosed, Gable/Hip, Building Category II (I = 1.00), h=B=L=15 ft, End Zone Truss, Both end webs considered. DOL = 1.60
- This truss has been designed for the effects of balanced and unbalanced snow loads for hips gables in accordance with ASCE7 - 02 except as noted, with the following user defined input: 40 psf ground snow load. NOTE: Conservatively, all flat/sloped roof factors have been ignored and the ground snow load has been used for the roof snow load. DOL = 1.15. If the roof configuration differs from hip/gable, Building Designer shall verify snow loads.
- This truss has been designed to account for the effects of ice dams forming at the eaves.
- This truss has been designed for the effects of a 18.1 psf live load computed in accordance with IBC 2003 assuming slope = 5.92 /12 and area supported = 24 ft².
- Minimum storage attic loading has been applied in accordance with IBC 1607.1

Member Forces Summary						
Table indicates: Member ID, max CSI, max axial force, (max compr. force if different from max axial force)						
TC	4-1	0.847	-1,340 lbs	1-2	0.868	-869 lbs
BC	3-1	0.596	-1,171 lbs	1-2	0.868	-869 lbs

- Notes:**
- When this truss has been chosen for quality assurance inspection, the Effective Tooth Count Method per TPI 1-2002/A3.4 shall be used.
 - Brace bottom chord with approved sheathing.
 - Multiple pinned bearings exist.

UNIQUE BEARING CONDITIONS AT JOINTS 4 & 5 REQUIRE SPECIAL ATTENTION
THE BUILDING DESIGNER MUST ACCOUNT FOR NOT ONLY THE BEARING REACTION BUT FOR THE HORIZONTAL THRUST AND THE UPLIFT. PROVIDE MECHANICAL CONNECTION (BY OTHERS) TO RESIST SAID FORCES SHOWN HEREON. THRUST = 1180lb/TRUSS

A copy of this design shall be furnished to the erection contractor. This design is for an individual building component (a truss). It is based on specifications provided by the Truss Designer and performed in accordance with TPI-1-2002 and the 2001 NDS design standard. No responsibility is assumed for the accuracy of information provided by the Truss Designer. Dimensions shall be verified by building designer. Creep deflection is not automatically accounted for by the software. The building designer shall review loading, truss configuration and initial deflection data shown to ensure that this design meets or exceeds minimum loading required by applicable building codes. Compression chords shall be laterally braced by the roof or floor sheathing, directly attached, unless otherwise noted. Bracing shown is for lateral support of individual truss components only to reduce buckling length. It is not wind or lateral load bracing or overall building design bracing which is by others. Refer to RCSI B recommended truss handling and erection. Do not apply loads beyond weight of erectors until all permanent bracing is in place. Concentration of construction loads greater than the design loads shall not be applied to the trusses at any time. Trusses shall be handled with care prior to erection to avoid damage. Lumber moisture content shall be 19% or less at the time of fabrication, unless noted otherwise (U.N.O.). Connector plates shall be manufactured by Eagle Metal Products (ESR-1082). Plates shall be applied on both faces of truss at each joint. Plate dimensions are listed with x length. Slots (holes) in plate shall run parallel to the plate length. The plate shall be centered on joint and/or placed in accordance with the current version of TPI assumes adequate anchorage will be provided to resist uplift at supports. The seal on this drawing indicates acceptance of professional engineering responsibility solely for the truss component design shown. The suitability and use of this component for any particular building design is the responsibility of the building designer, per ANSITPI 1-2002, Chapter 2.