

User Manual

Treviso LED Ceiling Fan

52 in. (1.32 m)

MODEL: 20314

120V 60Hz, MADE IN CHINA

Customer Assistance

1-866-885-4649

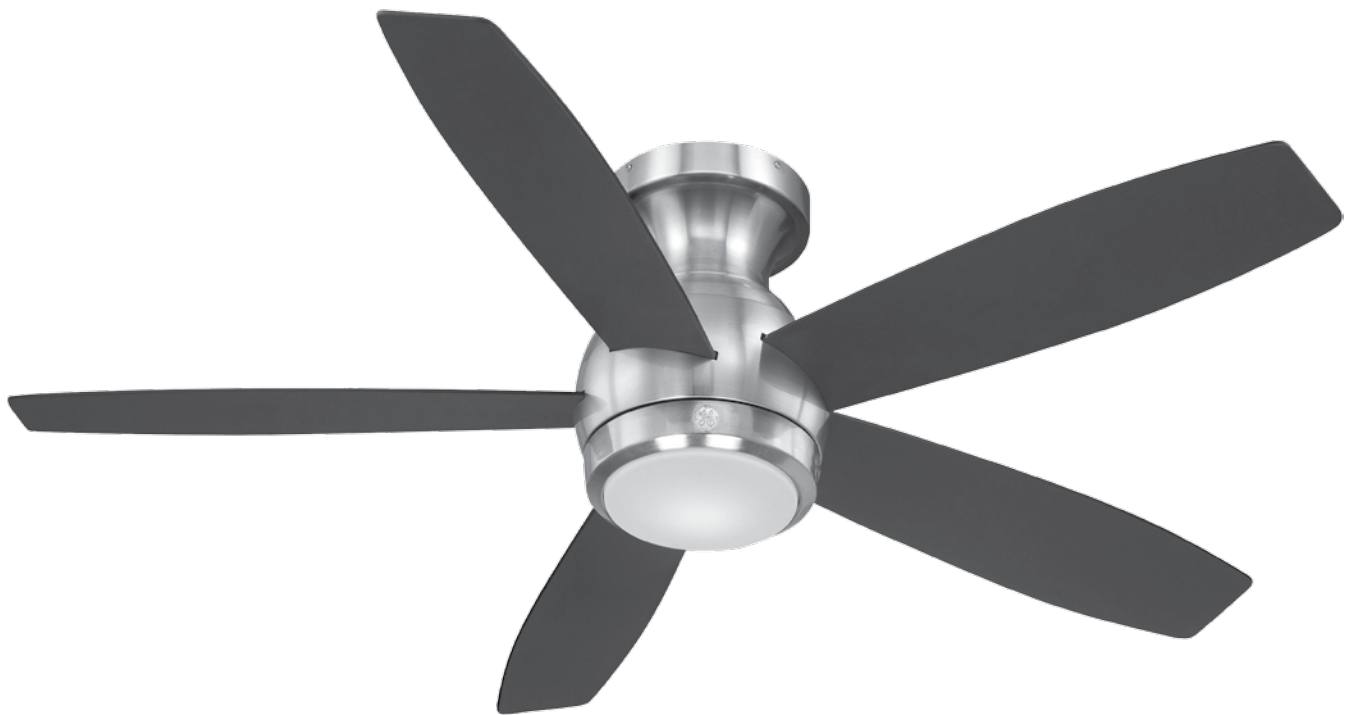

Contact a qualified electrician or call the Customer Care Service Team at 1-866-885-4649
Customer Service hours of operation are 9:00AM-5:00PM EST -Monday-Friday

Safety rules

1. To reduce the risk of electric shock, insure electricity has been turned off at the circuit breaker or fuse box before beginning.
2. All wiring must be in accordance with the latest edition of National Electrical Code “ANSI/NFPA 70” and local electrical codes. Electrical installation should be performed by a qualified licensed electrician.
3. **WARNING:** To reduce the risk of electrical shock or fire, do not use this fan with any solid-state fan speed control device. It will permanently damage the electronic circuitry.
4. **CAUTION:** To reduce the risk of personal injury, use only the screws provided with the outlet box.
5. The outlet box and support structure must be securely mounted and capable of reliably supporting a minimum of 15.9 kg (35 lb.). Use only UL Listed outlet boxes marked “FOR FAN SUPPORT.”
6. The fan must be mounted with a minimum of 2.1 m (7 ft.) clearance from the trailing edge of the blades to the floor.
7. Avoid placing objects in the path of the blades.
8. To avoid personal injury or damage to the fan and other items, be cautious when working around or cleaning the fan.
9. Do not use water or detergents when cleaning the fan or fan blades. A dry dust cloth or lightly dampened cloth will be suitable for cleaning.
10. After making electrical connections, spliced conductors should be turned upward and pushed carefully up into the outlet box. The wires should be spread apart with the grounded conductor and the equipment-grounding conductor on one side of the outlet box and ungrounded conductor on the other side of the outlet box.
11. All screws must be checked and re-tightened where necessary during installation.



WARNING: to reduce the risk of fire, electric shock or personal injury, mount fan to outlet box marked acceptable for fan support the screws provided with the outlet box.



WARNING: to reduce the risk of personal injury, do not bend the blade arms (also referred to as flanges), when installing the brackets, balancing the blades or cleaning the fan. Do not insert foreign objects in-between rotating fan blades.



WARNING: to reduce the risk of fire, electric shock or personal injury, mount to outlet box marked “acceptable for fan support of 15.9 kg (35 lb.) or less” and use mounting screws provided with the outlet box. Most outlet boxes commonly used for the support of light fixtures are not acceptable for fan support and may need to be replaced. Due to the complexity of the installation of this fan, a qualified licensed electrician is strongly recommended.

Basic guidelines for working with electricity

1. Before working on a circuit, go to the main service panel and remove the fuse or trip the breaker that controls that circuit.
2. Tape a sign to the panel warning others to leave the circuit alone while you work
3. Before touching any wire, use a voltage tester to make sure it's not live.
4. Whenever you check for voltage in a receptacle, check both outlets-each may be controlled by a separate wiring circuit.
5. When replacing fuses, turn off the main power first. Make sure your hands and feet are dry, and place one hand behind your back to prevent electricity from making a complete circuit through your chest. Touch a plug fuse only by its insulated rim.
6. Remove cartridge fuses with fuse puller.
7. Use tools with insulated handles and ladders made of wood or fiberglass.
8. To protect children, place safety cover over any unused outlets.

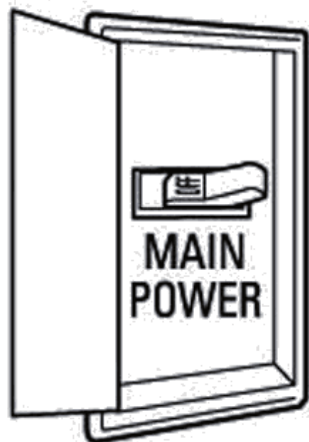

Shut off main power at the circuit breaker or fuse panel before removing old fixture.

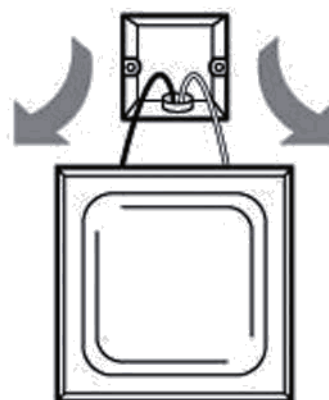

Remove old fixture. Disconnect wire.

To begin / tools needed (not supplied)

REQUIRED

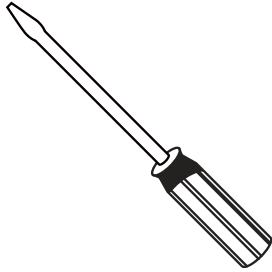

**Flathead
Screwdriver**

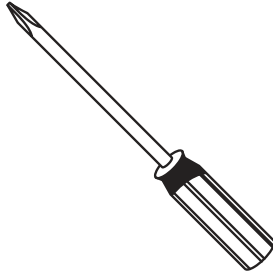

**Phillips
Screwdriver**

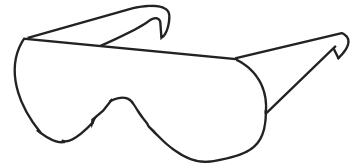

Safety Glasses

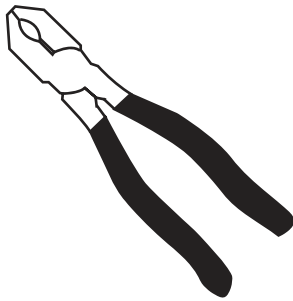

Pliers

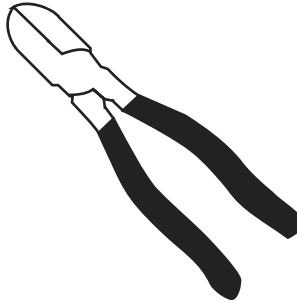

Wire Cutters



Electrical Tape

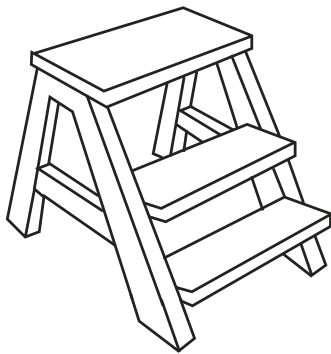

Step Ladder

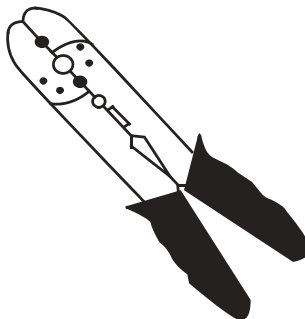

Wire Strippers

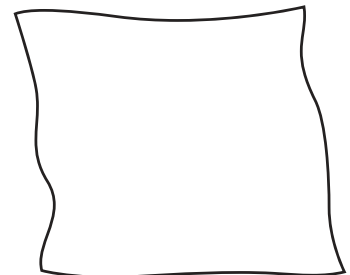

Soft Cloth

Hardware included

Carefully unpack and identify each part to make sure you have everything ready for installation. Lay out each part on a clean flat area such as a table or floor. Check to make sure you have the following:



ATTENTION: parts are not to scale.

Hardware Bag

Remote Control

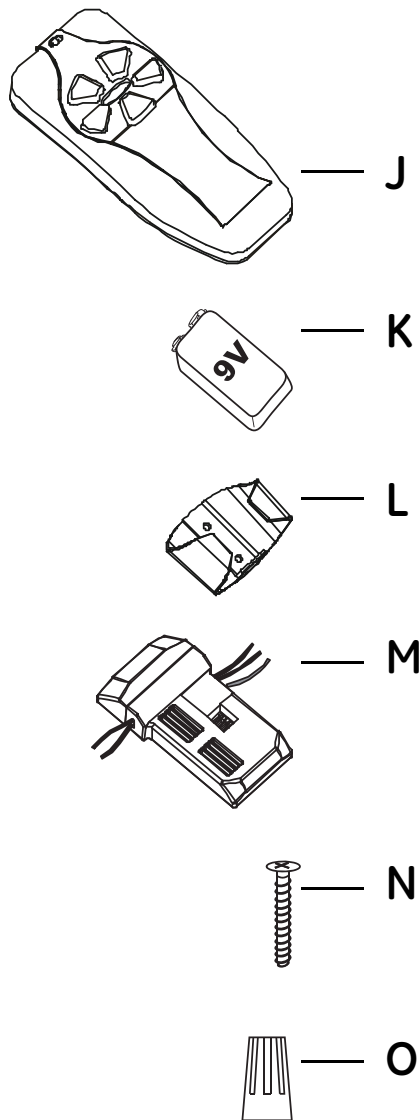
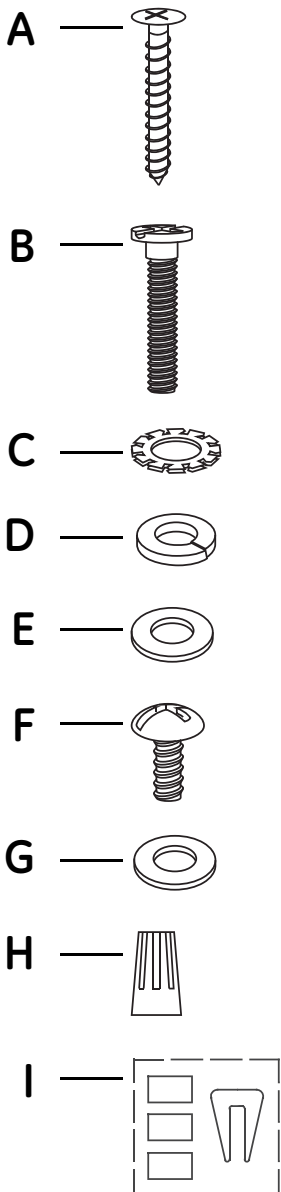

PART	DESCRIPTION	QUANTITY
A	Wood Screw (Long)	2
B	Mounting Screw	2
C	Star Washer	2
D	Spring Washer	2
E	Flat Washer	2
F	Blade Screw	15+1
G	Fibre Washer	15+1
H	Plastic Wire Nut	4
I	Balance Kit	1
J	Transmitter	1
K	9 Volt Battery	1
L	Transmitter Holder	1
M	Receiver	1
N	Wood Screw (Short)	2
O	Plastic Wire Nut	6

Package contents

Carefully unpack and identify each part to make sure you have everything ready for installation. Lay out each part on a clean flat area such as a table or floor. Check to make sure you have the following:



ATTENTION: parts are not to scale.

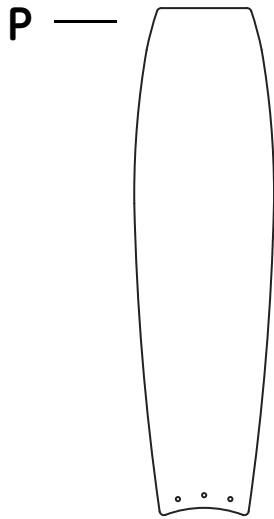

Functional Fasteners

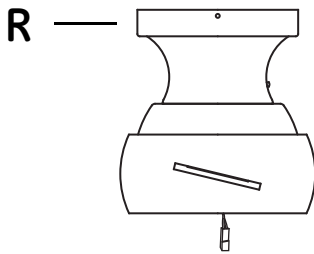
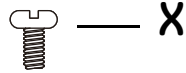
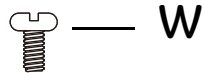
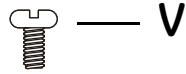

PART	DESCRIPTION	QUANTITY
P	Set Of Blades	5
Q	Mounting Bracket	1
R	Fan Motor Assembly	1
S	Mounting Plate	1
T	LED light kit	1
U	Glass Shade	1
V	Mounting Bracket Screw	4
W	Mounting Plate Screw	3
X	Light Kit Mounting Screw	3

Fan installation drawing



WARNING: review important safety instructions before installation

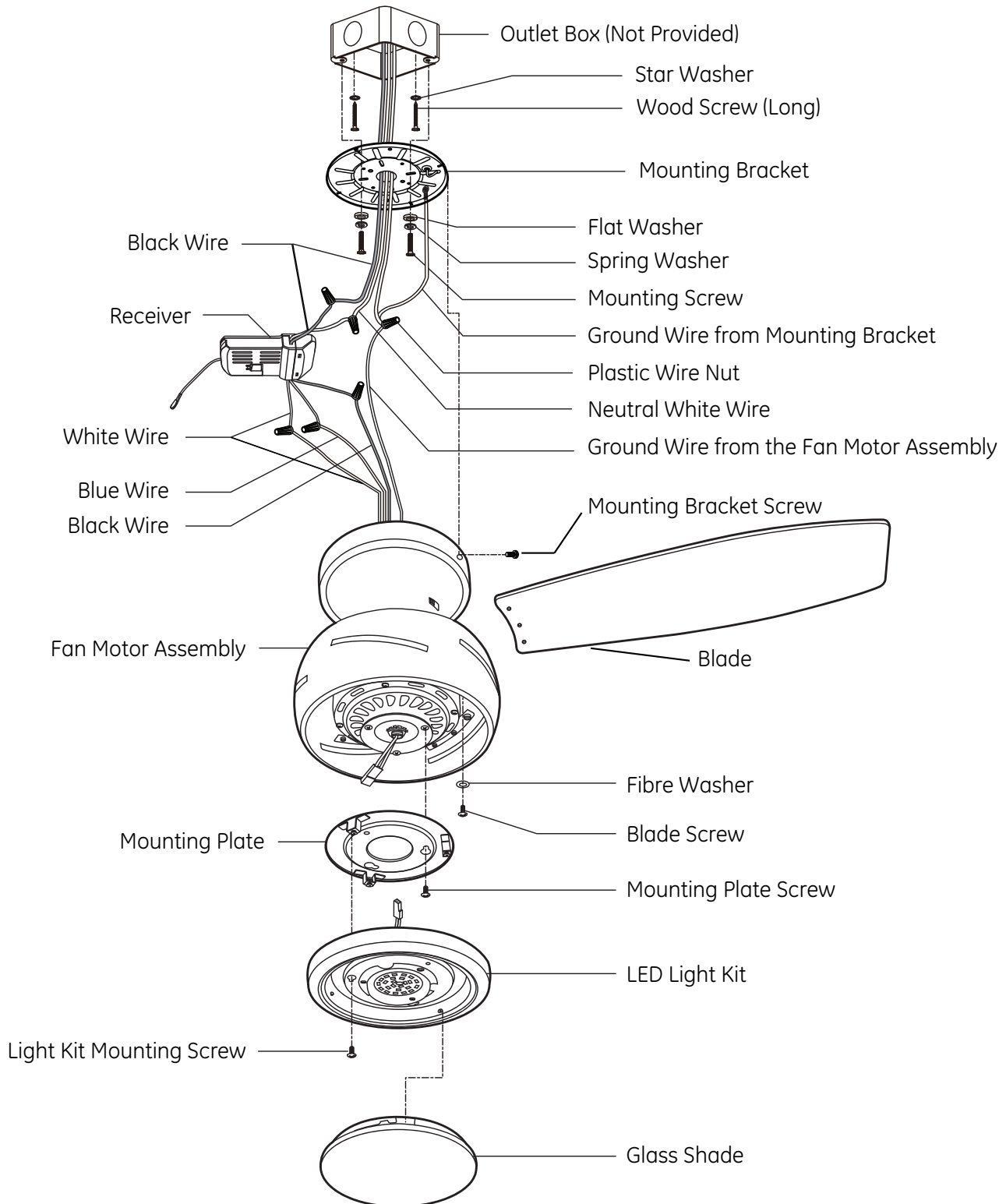

Fan installation

INSTALLING THE MOUNTING BRACKET

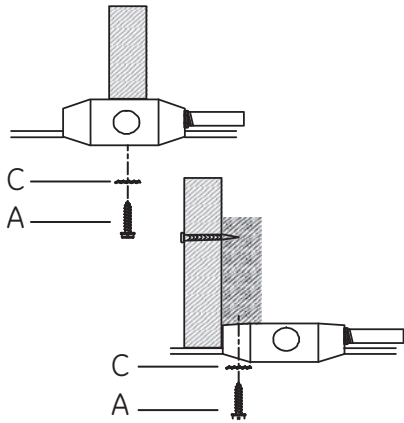

1. Use metal outlet box (sold separately) suitable for fan support. Secure outlet box directly to the building structure using wood screws (A) and star washers (C). Outlet box must support 15.9 kg (35 lb.) min.

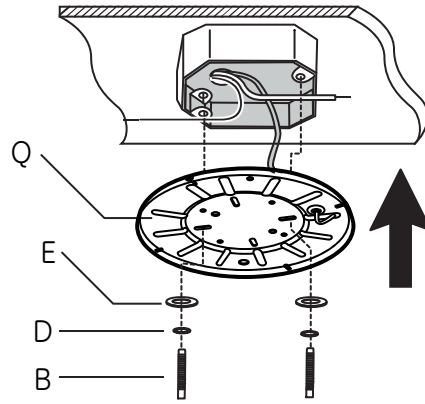

2. Install mounting bracket (Q) to the outlet box in ceiling using the mounting screws provided with the outlet box (two additional mounting screws (B), spring washers (D) and flat washers (E) are provided in the hardware bag).

HANGING THE FAN

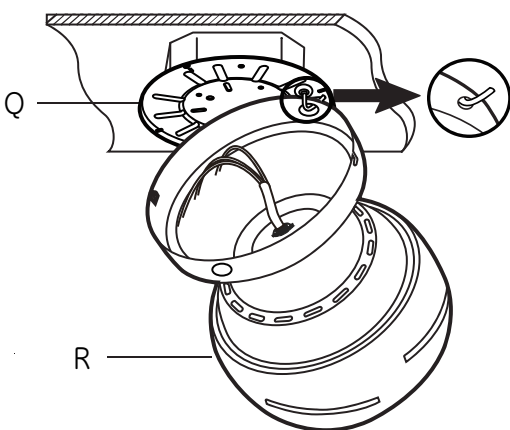

1. Lift the fan into position by hanging the fan motor assembly (R) onto the hook from the ceiling mounting bracket (Q) allowing it to hang freely.

Fan installation

PREPARING THE ELECTRICAL CONNECTIONS



WARNING: to avoid possible electric shock, be sure electricity is turned off at the main fuse box before wiring.

If you feel you do not have enough electrical wiring knowledge or experience, have your fan installed by a licensed electrician.

Follow the steps below to prepare the electrical connections. After that, conform with the descriptions and diagrams on next pages to connect the fan to your household wiring. Use the wire nuts supplied with your fan. Secure the wire nuts with electrical tape. Make sure there are no loose strands or connections.

1. This remote control unit is equipped with 16 code combinations to prevent possible interference from or to other remote units. The frequency switches on your receiver (M) and transmitter (J) have been preset at the factory. Please recheck to make sure the switches on the transmitter (J) and the receiver (M) are set to the same position, any combination of settings will operate the fan as long as the transmitter (J) and receiver (M) are set to the same position.

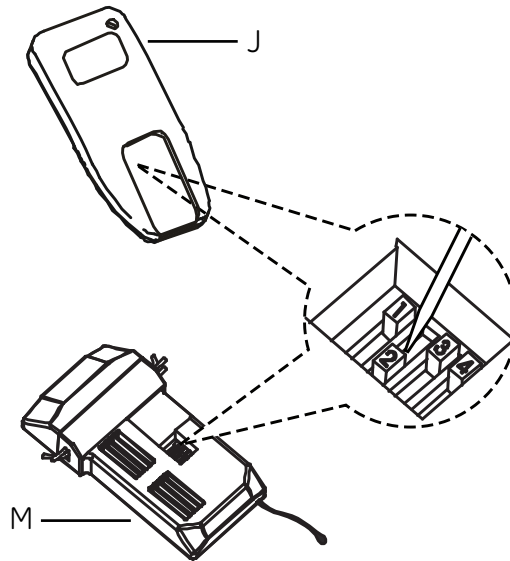

Fan installation

MAKING THE ELECTRICAL CONNECTIONS

Motor to receiver electrical connections: Connect the black wire from the fan to black wire marked "TO MOTOR L" from the receiver. Connect the white wire from the fan to the white wire marked "TO MOTOR N" from the receiver. Connect the blue wire from the fan to the blue wire marked "For Light" from the receiver. Secure the wire connections with the plastic wire nuts (O).

Receiver to house supply wires electrical connections: Connect the black (hot) wire from the ceiling to the black wire marked "AC in L" from the receiver. Connect the white (neutral) wire from the ceiling to the white wire marked "AC in N" from the receiver. Secure the wire connections with the plastic wire nuts (H).

If your outlet box has a ground wire (green or bare copper), connect it to the ground wire from mounting bracket and ground wire from the fan motor assembly, secure the wire connection with a plastic wire nut (H); otherwise connect the ground wire from the fan motor assembly to the ground wire from mounting bracket, secure the wire connection with plastic wire nut (H).

WARNING: to avoid possible electric shock, be sure electricity is turned off at the main fuse box before wiring.

NOTE: fan must be installed at a maximum distance of 6 m (20 ft.) from the transmitting unit for proper signal transmission between the transmitting unit and fan's receiving unit

CAUTION: do not use wall switch with dimmer function.

WARNING: check to see that all connections are tight, including ground wire, and that no bare wire is visible at the wire nuts, except for the ground wire.

WARNING: electrical diagrams are for reference only. Optional use of any light kit shall be UL listed and marked suitable for use with this fan.

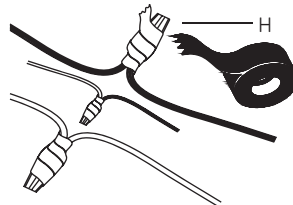
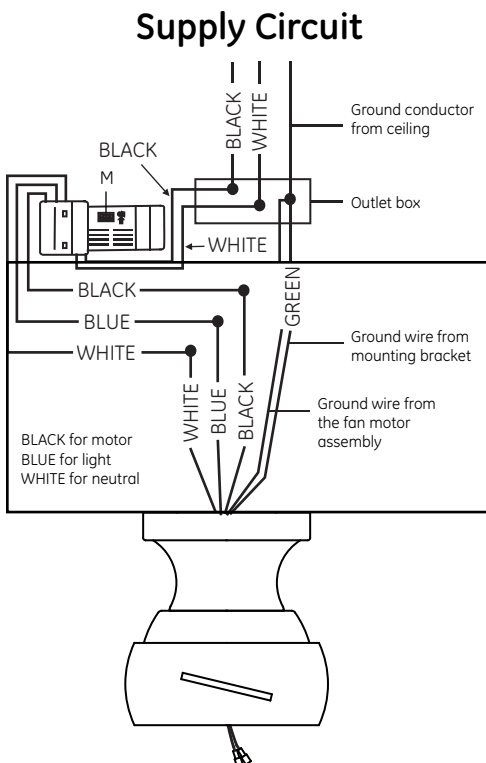

To install wire nuts, strip wires 1.9 cm (3/4 in). Line up wires in parallel, insert into wire nut, hand tight wire nut by twisting clockwise until snug. Tape around wires and wire nut. After connecting the wires, carefully tuck the wire connections and wires into the canopy.

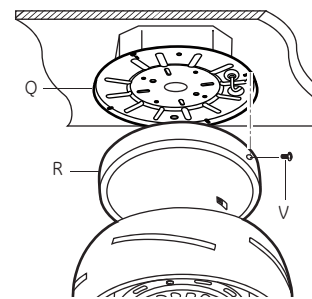

Loosen two (one of each across) of the four screws (V) from the mounting bracket (Q) and remove the other two. Remove the motor assembly (R) from the hook of mounting bracket (Q) and push up the motor assembly (R) until the two screws (V) on mounting bracket (Q) are engaged with L type slot holes on canopy of the motor assembly (R). Rotate the motor assembly (R) slightly until the two screw heads are in the L type slot holes. Install the two screws previously removed and tighten all four screws.

Fan installation

ATTACHING THE FAN BLADES

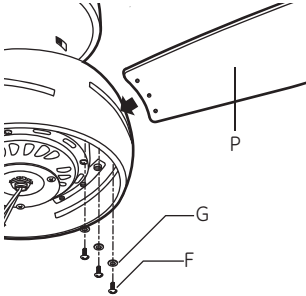

Insert the blade (P) through the slot in the bottom band, align the holes in the blade (P) and the bracket, secure with the blade screws (F) and fibre washers (G) provided. Repeat this procedure with the other blades (P).



NOTE: before starting installation, disconnect the power by turning off the circuit breaker or removing the fuse at fuse box. Turning power off using the fan switch may not be sufficient to prevent electric shock.

INSTALLING THE LIGHT KIT

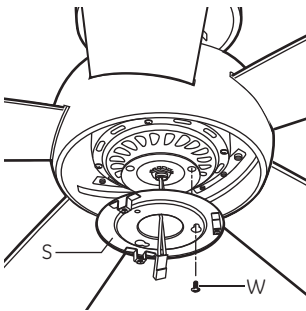

Remove the 1 of 3 mounting plate screws (W) from the bottom of motor assembly (R) and keep it for future use. Loosen the other 2 screws (do not remove). Place the key holes on the mounting plate (S) over the 2 mounting plate screws (W) previously loosened, turn the mounting plate (S) until it locks in place at the narrow section of the key holes. Secure by tightening the 2 screws previously loosened and the one previously removed.

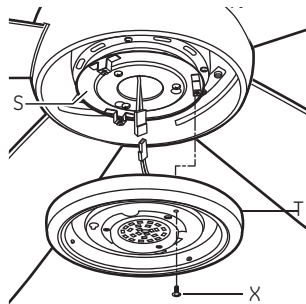

Remove the 1 of 3 light kit mounting screws (X) from the mounting plate (S) and keep it for future use. Loosen the other 2 screws (do not remove). While holding the LED light kit (T) under the fan motor assembly, make the 2-pin wire connections: -Red to red and black to black. Place the key holes on the LED light kit (T) over the 2 light kit mounting screws (X) previously loosened, turn the LED light kit (T) until it locks in place at the narrow section of key holes. Secure by tightening the 2 screws previously loosened and the one previously removed.

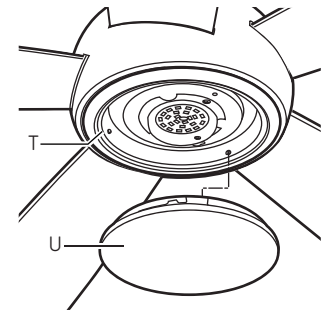

Raise glass shade (U) up against the light kit (T) and secure it to fan by twisting glass (U) clockwise until snug. Do not over-tighten.

Operation instructions

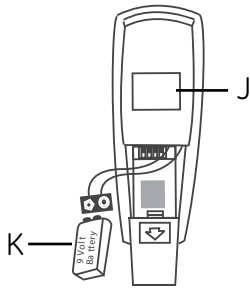

1. Install a 9-volt battery (K) (included).

Note: to prevent damage to transmitter (J), remove the battery if not used for long periods.

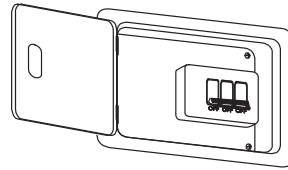

2. Restore power to ceiling fan and test for proper operation.

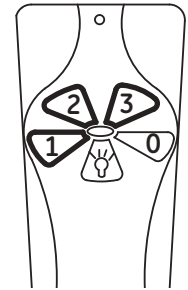

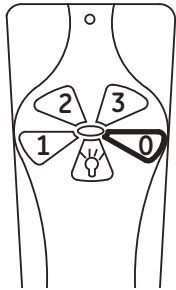

3. "1, 2, and 3 buttons: These three buttons are used to set the fan speed as follows: 1 = high speed 2 = medium speed 3 = low speed

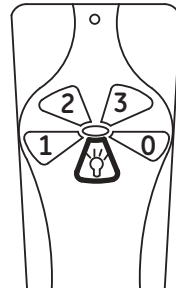

4. "0" button: This button turns the fan off.

Speed settings for warm or cool weather depend on factors such as the room size, ceiling height, number of fans, and so on.



5.  button: test for proper operation.

This button controls the light and also controls the brightness setting. Press and release the button to turn the light ON or OFF. Press and hold the button to set the desired brightness. The light key has an auto-resume; it will stay at the same brightness as the last time it was turned off.

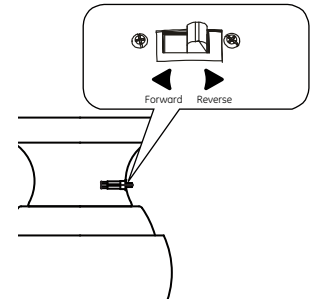

6. The reverse switch is located on the top of motor housing. Slide reverse switch to change fan rotation. Slide the switch to the left for warm weather operation. Slide the switch to the right for cool weather operation.

Note: wait for fan to stop before reversing the direction of the blade rotation.

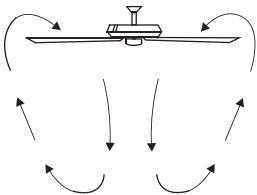

7. Warm weather - (Switch to the left - Counterclockwise direction) A downward air flow creates a cooling effect as shown. This allows you to set your air conditioner on a higher setting without affecting your comfort.

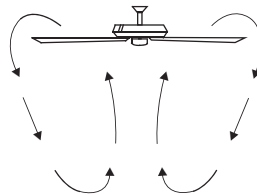

8. Cool weather - (Switch to the right - Clockwise direction) An upward air flow moves warm air off the ceiling as shown. This allows you to set your heating unit on a lower setting without affecting your comfort.

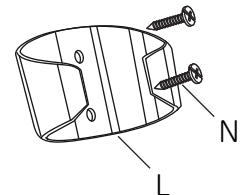

9. Select a location to install your Transmitter holder (L). Attach the transmitter holder (L) with the two short wood screws (N) provided.

Blade balancing

The following procedure should correct most fan wobble. Check after each step.

Check that all blade and blade bracket screws are secure.

Most fan wobble problems are caused when blade levels are unequal. Check this level by selecting a point on the ceiling above the tip of one of the blades. Measure from a point on the centre of each blade to the point on the ceiling. Measure this distance as shown in figure. Rotate the fan until the next blade is positioned for measurement. Repeat for each blade. Measurements deviation should be within 3 mm (1/8 in.). Run the fan for 10 minutes.

Use the enclosed Blade Balancing Kit if the blade wobble is still noticeable.

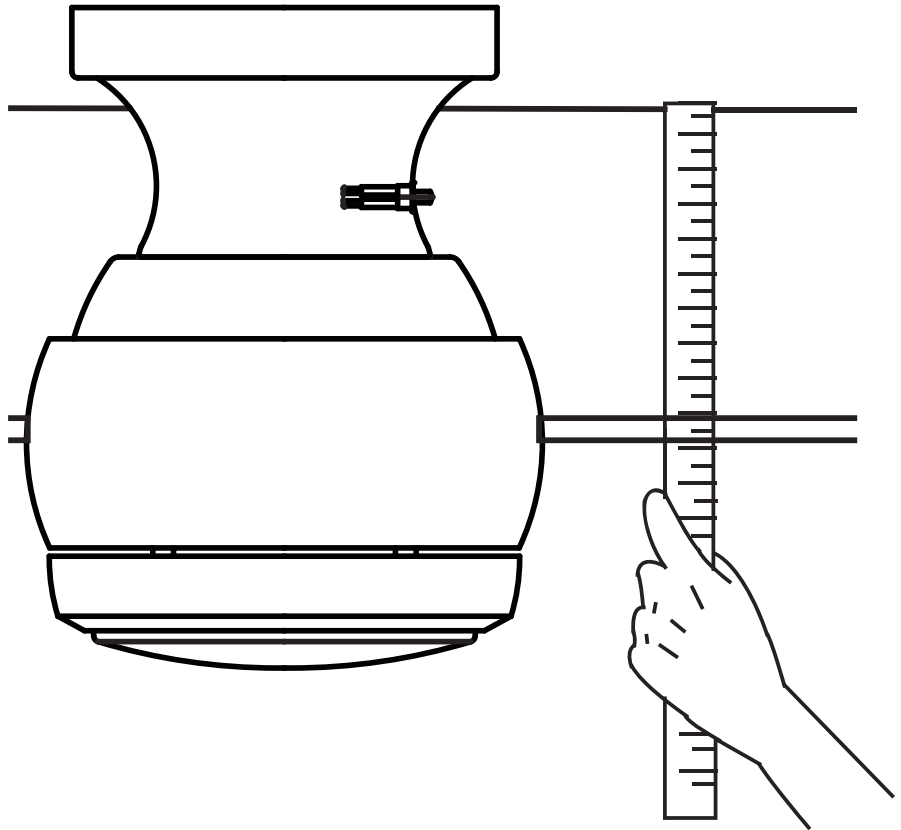

This device complies with part 15 of the FCC Rules. Operation is subject to the following two conditions:

- (1) This device may not cause harmful interference, and
- (2) this device must accept any interference received, including interference that may cause undesired operation.

CAUTION: Any changes or modifications not expressly approved by the party responsible for compliance could void the user's authority to operate the equipment.

Note: This equipment has been tested and found to comply with the limits for a Class B digital device, pursuant to part 15 of the FCC Rules. These limits are designed to provide reasonable protection against harmful interference in a residential installation. This equipment generates, uses and can radiate radio frequency energy and, if not installed and used in accordance with the instructions, may cause harmful interference to radio communications. However, there is no guarantee that interference will not occur in a particular installation. If this equipment does cause harmful interference to radio or television reception, which can be determined by turning the equipment off and on, the user is encouraged to try to correct the interference by one or more of the following measures:

- Reorient or relocate the receiving antenna.
- Increase the separation between the equipment and the receiver.
- Connect the equipment into an outlet on a circuit different from that to which the receiver is connected.
- Consult the dealer or an experienced radio / TV technician for help.

Blade Balancing Kit

The balancing kit should only be used if there is an unacceptable amount of fan wobble after completing all the steps in the user manual under “Fan Blades Assembly”.

1. Turn the fan on and set the speed control setting to a speed at which the wobble is the greatest.

2. Turn off the fan and allow it to come to a complete stop. Mark the blades with masking tape number 1-5. Select one blade and place the balance clip on it halfway between the blade holder and the blade tip on the trailing edge of the blade.

3. Turn the fan on. Note whether the wobble has increased or decreased. Turn the fan off, move the clip to another blade, and retest. Repeat this procedure on all blades noting the blade on which the greatest improvement is achieved.

4. Adjust the clip on this blade as shown in the illustration and operate the fan to find the position where the clip gives the greatest improvement.

5. Remove the clip, clean the area where the weight is to be added, and install a balancing weight to the top of the blade along the center line near the point where the clip was positioned on the blade.

6. If the fan wobble problem has not been corrected, you may wish to try to improve the balancing further by using the balancing clip and additional weights.

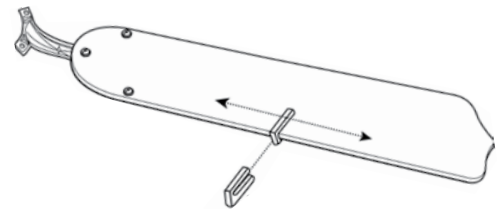

Attach the plastic clip on blade

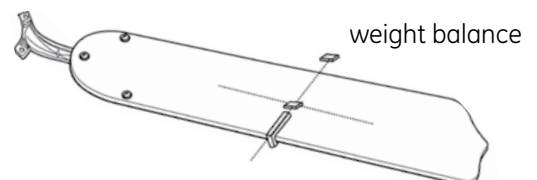
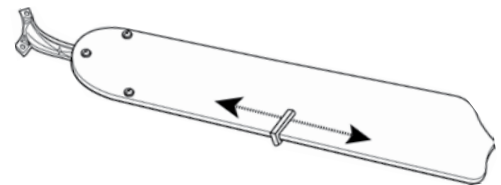

Safety instructions

PRODUCT MAINTENANCE

Here are some suggestions to help you maintain your fan.

Because of the fan's natural movement, some connections may become loose. Check the support connections, brackets, and blade attachments twice a year. Make sure they are secure. (It is not necessary to remove fan from ceiling.)

Clean your fan periodically to help maintain its new appearance over the years. Use only a soft brush or lint-free cloth to avoid scratching the finish. The plating is sealed with a lacquer to minimize discolouration or tarnishing. Do not use water when cleaning. This could damage the motor, the wood, or possibly cause an electrical shock.

You can apply a light coat of furniture polish to the wood blades for additional protection and enhanced beauty. Cover small scratches with a light application of shoe polish.

There is no need to oil your fan. The motor has permanently lubricated sealed ball bearings.



WARNING: make sure the power is off at the electrical panel box before you attempt any repairs. Refer to the section "Making Electrical Connections."

TROUBLESHOOTING

PROBLEM	SOLUTION
Fan will not start	<ul style="list-style-type: none"> -Check main and branch circuit fuses or breakers. -Check line wire connections to the fan and switch wire connections in the switch housing -Check to make sure the dip switches from the transmitter and receiver are set to the same frequency
Fan sounds noisy	<ul style="list-style-type: none"> -Make sure all motor housing screws are snug -Make sure the screws that attach the fan blade bracket to the motor hub is tight -Make sure wire nut connections are not rattling against each other or the interior wall of the switch housing -Allow a 24-hour "breaking-in" period. Most noises associated with a new fan disappear during this time. -If using a ceiling fan light kit, make sure the screws securing the glassware are tight. Check that the light bulb is also secure. -Make sure there is a short distance from the ceiling to the canopy. It should not touch the ceiling. -Make sure your ceiling box is secure and rubber isolator pads are used between mounting bracket and outlet box.
Remote control	<ul style="list-style-type: none"> -Do not connect the fan with a wall mounted variable speed control (s). -Make sure the dip switches are set correctly.



is a trademark of General Electric Company
and is under license by Safety Quick Lighting & Fans Corp.
4400 North Point Parkway, Suite 154, Alpharetta, GA 30022