

AROMA®

PROFESSIONAL™

Instruction Manual

Electric Kettle



Questions or concerns about your electric kettle?

Before returning to the store...



Aroma's customer service experts are happy to help. Call us toll-free at **1-800-276-6286**.



Answers to many common questions and even replacement parts can be found online. Visit **www.AromaCo.com/Support**.





Congratulations on your purchase of the Aroma® Digital Electric Kettle– the best way to boil! This digital electric kettle is the ideal solution for any need in the kitchen that calls for boiling water in a hurry. It's perfect for soothing tea, an easy bowl of noodles, an invigorating cup of instant coffee, a hearty helping of oatmeal, delicious hot chocolate and the list goes on and on.

Faster than the stovetop, your new kettle will boil water at a blazing cup-a-minute speed. And there's no need to worry about a forgotten kettle, as the digital electric kettle shuts off automatically once water has boiled.

The 100% stainless steel interior is perfect for boiling water for your favorite hot drinks and meals. And serving hot beverages to friends and family has never been easier as the electric kettle lifts off the power base for cordless pouring.

For more information on your Aroma® Digital Electric Kettle, or for product service, replacement parts and other home appliance solutions, please visit us online at www.AromaCo.com.



www.AromaTestKitchen.com



www.facebook.com/AromaHousewares



www.twitter.com/AromaHousewares



www.pinterest.com/AromaHousewares



Published By:
Aroma Housewares Co.
6469 Flanders Drive
San Diego, CA 92121
U.S.A.

1-800-276-6286

www.AromaCo.com

©2014 Aroma Housewares Company
All rights reserved.





IMPORTANT SAFEGUARDS

When using electrical appliances basic safety precautions should always be followed, including the following:

1. Read all instructions carefully before using the appliance.
2. Do not touch hot surfaces. Use handles or knobs. Metal surfaces become extremely hot.
3. To protect against fire, electric shock and injury to persons, do not immerse cord, plug or kettle in water or any other liquid. See instructions for cleaning.
4. Close supervision is necessary when the appliance is used by or near children.
5. Always unplug the appliance from the outlet when not in use and before cleaning. Allow the kettle to cool completely before putting on or taking off parts, and before cleaning the appliance.
6. Do not operate appliance with a damaged cord or plug, or after appliance malfunctions or has been damaged in any manner. Contact Aroma® customer service for examination, repair or electrical/mechanical adjustment.
7. The use of accessory attachments not recommended by Aroma® Housewares may result in fire, electrical shock or injury.
8. Do not use outdoors.
9. Do not let cord hang over the edge of a table or counter or to touch hot surfaces.
10. Do not place kettle on or near a hot gas or electric burner or in a heated oven.
11. To disconnect, turn any control to the "OFF" position, then remove the plug from the wall outlet.
12. Always unplug from the base of the wall outlet. Never pull on the cord.
13. Only use the kettle to heat water. No other liquids should be placed inside the kettle.
14. Do not use kettle for other than its intended use.
15. The power base must only be used with the provided kettle.
16. Do not unscrew any screws on the kettle or power base or attempt to disassemble them in any way.
17. Do not move kettle during the heating process.
18. This appliance is for household use only.
19. Do not immerse this appliance or any of its parts in water.
20. Scalding may occur if the lid is removed during the boiling cycle.
21. **Caution:** If water exceeds the "MAX" line, the boiled water may spill out.
22. Use only on a level, dry and heat-resistant surface.
23. The electric kettle should be operated on a separate electrical circuit from other operating appliances. If the electrical circuit is overloaded with other appliances the electric kettle may not operate properly.
24. Do not open the kettle lid when in operation.

SAVE THESE INSTRUCTIONS



IMPORTANT SAFEGUARDS

Short Cord Instructions

1. A short power-supply cord is provided to reduce the risks resulting from becoming entangled in or tripping over a longer cord.
2. Longer extension cords are available and may be used if care is exercised in their use.
3. If a longer extension cord is used:
 - a. The marked electrical rating of the extension cord should be at least as great as the electrical rating of the appliance.
 - b. The longer cord should be arranged so that it will not drape over the counter top or tabletop where it can be pulled by children or tripped over unintentionally.

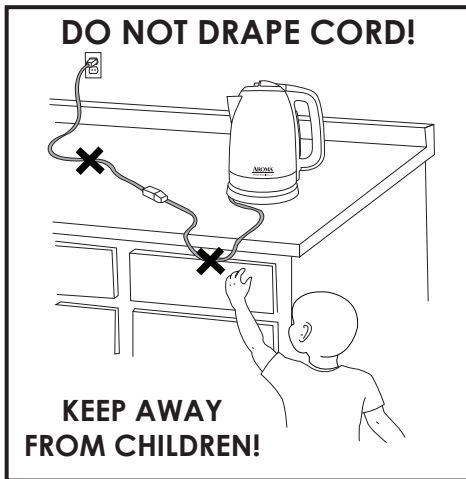

Polarized Plug

This appliance has a **polarized plug** (one blade is wider than the other); follow the instructions below:

To reduce the risk of electric shock, this plug is intended to fit into a polarized outlet only one way. If the plug does not fit fully into the outlet, reverse the plug. If it still does not fit, contact a qualified electrician. Do not attempt to modify the plug in any way.

If the supply cord is damaged, it must be replaced by the manufacturer, its service agent or a similarly qualified person in order to avoid a hazard.

THIS APPLIANCE IS FOR HOUSEHOLD USE ONLY.



PARTS IDENTIFICATION

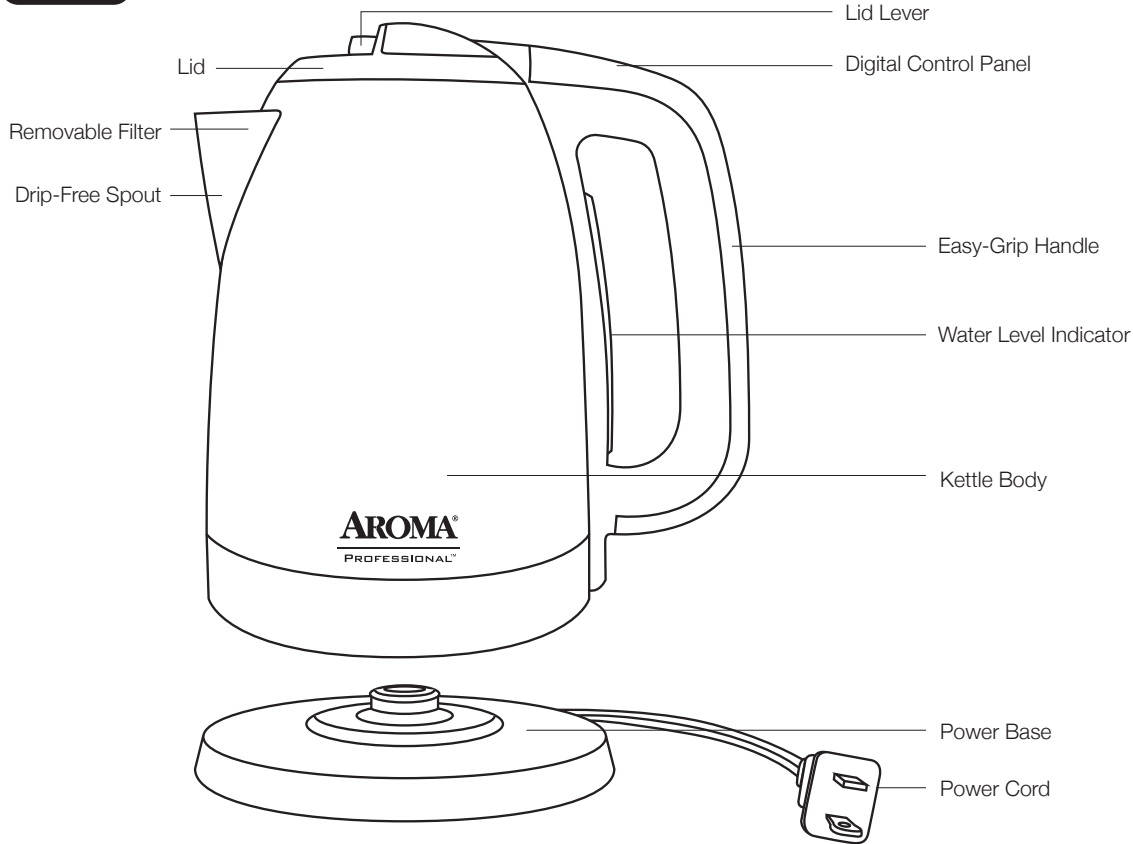

Digital Control Panel

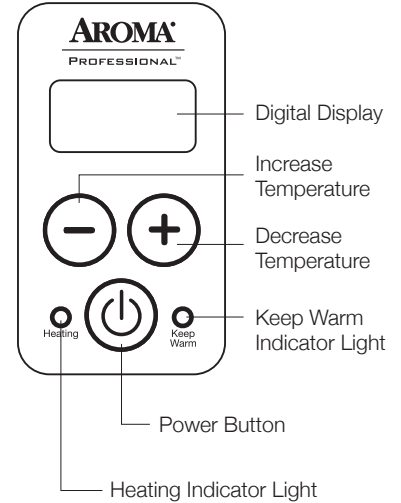



BEFORE FIRST USE

Before using for the first time, it is recommended to clean the interior of the kettle thoroughly. Please follow the procedures below before using the kettle:

1. Remove all packing materials and make sure that the product has been received in good condition.
2. Taking care to keep the electrical components on the exterior of the kettle dry, wipe the interior of the kettle with a damp cloth. If your hand will not fit inside the kettle, swish warm, soapy water around in the interior of the kettle with the lid closed.
3. Rinse out the inside of the kettle thoroughly with water.
4. With a damp cloth, gently wipe off the exterior of the kettle. Do not wipe electrical components as this may cause damage to the unit.
5. Dry all parts completely.
6. **It is recommended to run your kettle through one boiling cycle before using it to consume beverages.** Following the instructions in “To Boil Water” on **page 5**, boil a full kettle of water. When water has boiled, pour it out and rinse the inside of the kettle once more. The kettle is now ready for use.



NOTE

- Do not use abrasive cleaners or scouring pads.
- Do not immerse the kettle body or power base in water at any time.



TO BOIL WATER

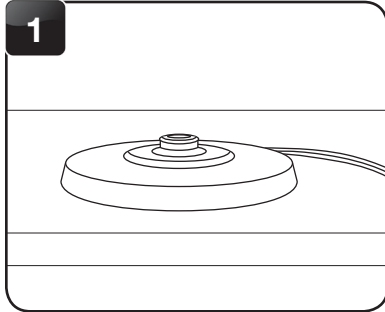

1 Place the Power Base on a sturdy, level and dry surface.

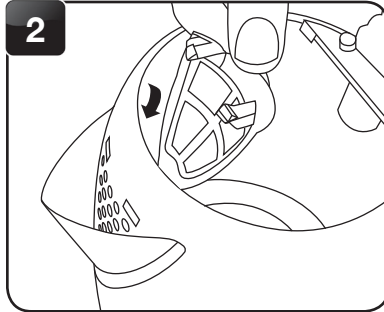

2 Make sure that the Removable Filter is properly inserted. See “Removing and Inserting the Filter” on page 11 for instructions on inserting the filter.

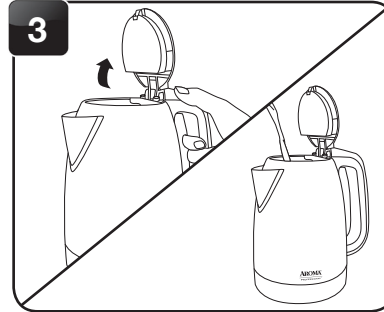

3 Open the lid and fill with water through the lid opening. Water must be filled between the “Min” and “Max” levels inside the kettle.



4 Close the lid, ensuring it locks into place.



CAUTION

- Never fill the kettle with any liquids other than water.
- Use distilled water when possible for best taste and to minimize mineral build-up in the kettle.



TO BOIL WATER (CONT.)

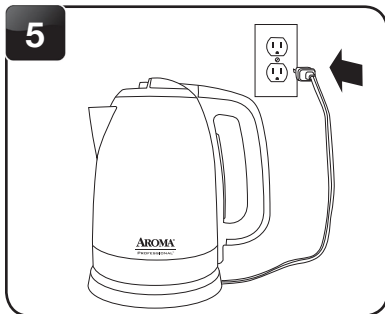

5 Plug the Power Cord into a wall outlet and place the kettle onto the Power Base. The kettle will “beep” once to indicate it is on.

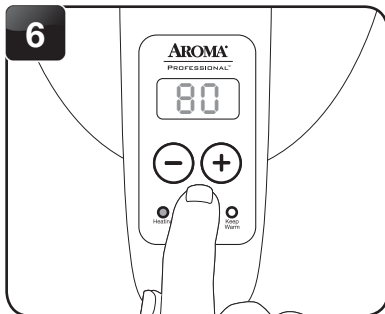

6 Press the POWER (⏻) button to turn the kettle on. The Heating Indicator will illuminate, the Digital Display will display “80” and the kettle will begin heating the water. As the water begins to heat, the Digital Display will show the temperature in real time.

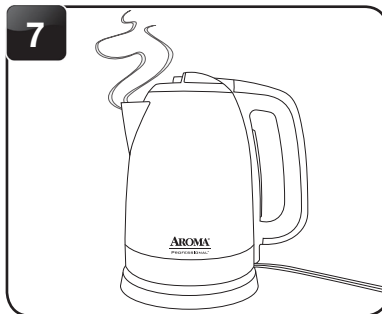

7 Once the water reaches a boil, the kettle will “beep” three times and automatically stop heating.

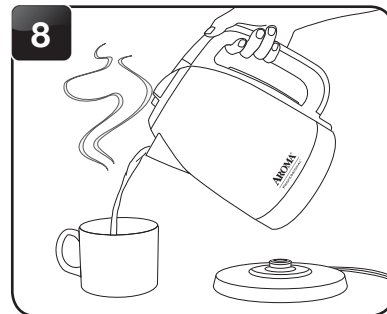

8 Using the Easy-Grip Handle, lift the kettle off the Power Base to serve. Do not touch the stainless steel body, as it will be hot.

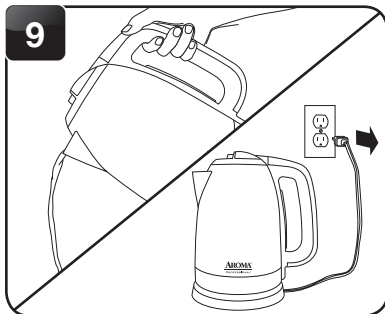

9 When finished serving, pour out any remaining water and unplug the Power Cord.



NOTE

- Never open the lid while water is boiling.
- If the kettle is heated with no water, the internal safety mechanism will automatically turn the kettle off.
- If the lid is not completely closed the kettle will not automatically turn off.



USING THE KEEP WARM TEMPERATURES

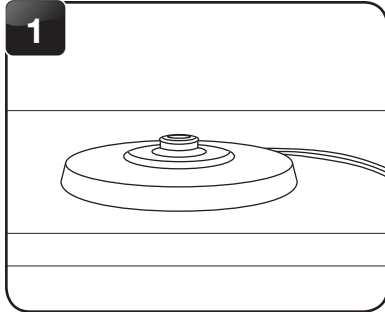

1 Place the Power Base on a sturdy, level and dry surface.

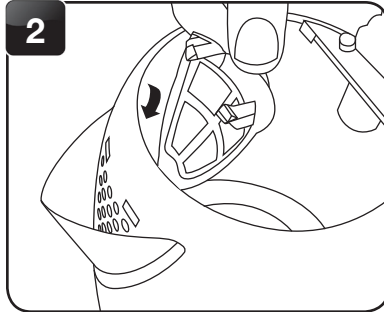

2 Make sure that the Removable Filter is properly inserted. See “Removing and Inserting the Filter” on page 11 for instructions on inserting the filter.

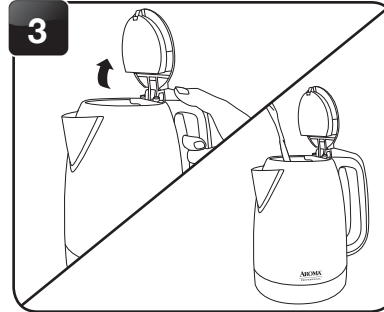

3 Open the lid and fill with water through the lid opening. Water must be filled between the “Min” and “Max” levels inside the kettle.



4 Close the lid, ensuring it locks into place.



CAUTION

- Never fill the kettle with any liquids other than water.
- Use distilled water when possible for best taste and to minimize mineral build-up in the kettle.



USING THE KEEP WARM TEMPERATURES (CONT.)

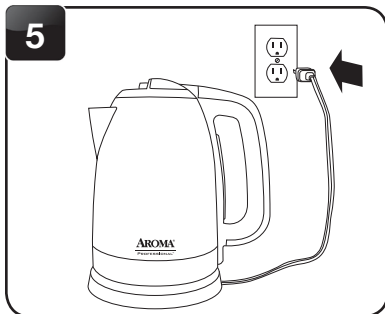

5 Plug the Power Cord into a wall outlet and place the kettle onto the Power Base. The kettle will “beep” once to indicate it is on.

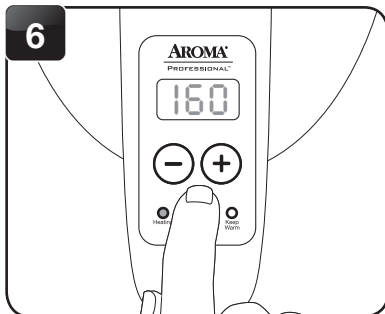

6 Press the POWER (⏻) button to turn the kettle on. The Heating Indicator will illuminate, the Digital Display will display “160” and the kettle will begin heating the water. As the water begins to heat, the Digital Display will show the temperature in real time.

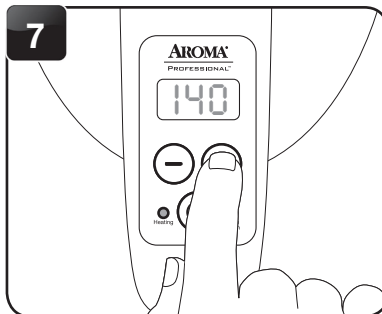

7 Pressing the + or – buttons will increase or decrease the temperature in 10 degree intervals between 120 and 200 degrees.

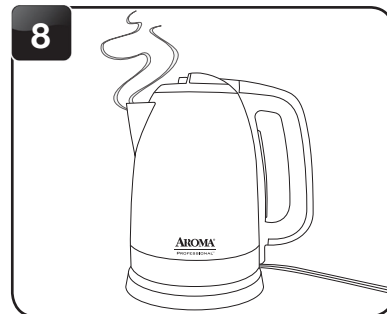

8 Once the desired temperature setting is reached, the kettle will beep 3 times and stop heating. The kettle will heat occasionally in order to maintain the selected temperature.



NOTE

- Do not use abrasive cleaners or scouring pads.
- Do not immerse the kettle body or power base in water at any time.



USING THE KEEP WARM TEMPERATURES (CONT.)

9

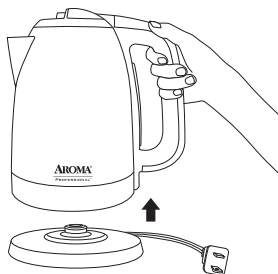

Using the easy-grip handle, lift the kettle off the Power Base to serve. Do not touch the stainless steel body, as it will be hot. Lifting the kettle off the Power Base will turn it off.

10



After pouring, make sure the bottom of the kettle and the Power Base are dry before placing kettle back on the Power Base.

11

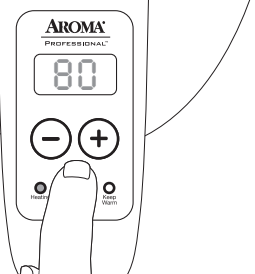

To continue using the Keep warm setting, press the POWER (button icon) button to turn the kettle on. Press the POWER (button icon) button again to activate the Keep Warm setting and select the desired temperature by pressing the + or - buttons.

12

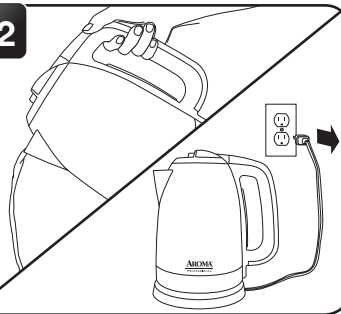

When finished serving, pour out any remaining water and unplug the power cord.



CAUTION

- Never fill the kettle with any liquids other than water.
- Use distilled water when possible for best taste and to minimize mineral build-up in the kettle.



USING THE KEEP WARM TEMPERATURES (CONT.)

SUGGESTED KEEP WARM USES

SUGGESTED USE	TEMPERATURE
French Press Coffee	195°F
Oolong Tea	185°F
Green Tea	160°F
Black Tea	212°F
White Tea	175°F
Herbal Tea	212°F
Noodles	212°F
Oatmeal	212°F
Formula	95°F
Hot Chocolate	212°F



NOTE

- Never fill the kettle with any liquids other than water.



REMOVING AND INSERTING THE FILTER

To remove the filter:



1
Do not attempt to remove filter until the unit has cooled completely. Open the lid.

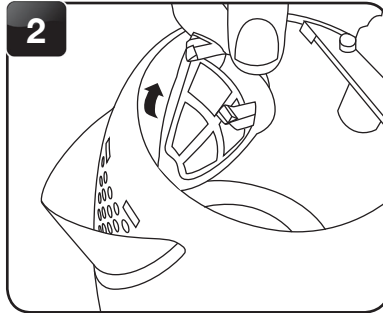

2
Grasp the angled tab on the filter and pull upward. The filter should slide out easily.

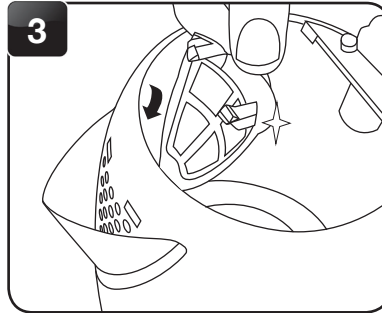

3
Wash and rinse the filter, then replace.

To insert the filter:

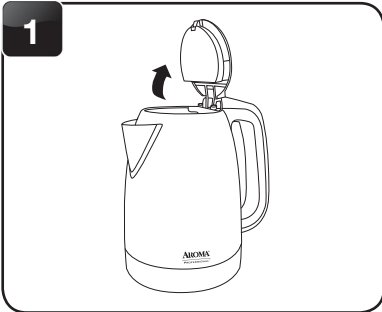

1
Open the lid

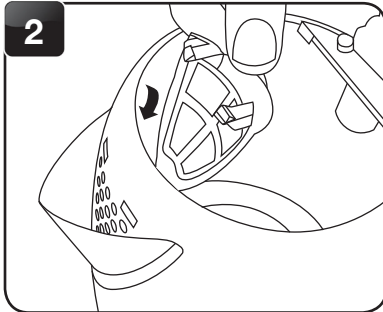

2
Grasping the filter at the angled tab, slide the filter into the slots on the inside of the spout until the filter sits securely into place.

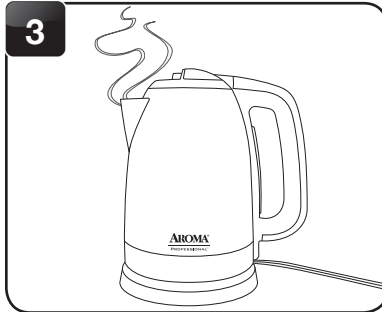

3
Once the filter is securely in place, the kettle will be ready for use.



NOTE

- It is necessary for the filter to be properly in place for the kettle to shut off automatically.



HELPFUL HINT

- Misplace your filter? Replacement parts are available online at www.AromaCo.com or contact Aroma® Customer Service toll-free at 1-800-276-6286.



TO CLEAN

Always unplug the kettle and allow it to cool completely before cleaning.



1 Wipe the exterior of the kettle with a damp cloth, taking care to avoid the electrical components.

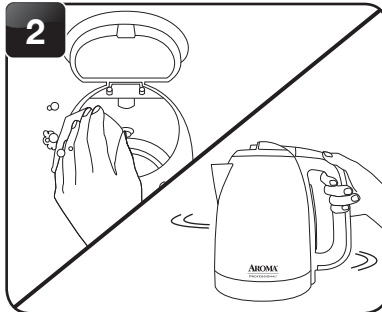

2 Clean the interior of the kettle with a soft sponge and warm, soapy water. If your hand does not fit in the lid opening, swish warm, soapy water around inside the kettle with the lid closed.

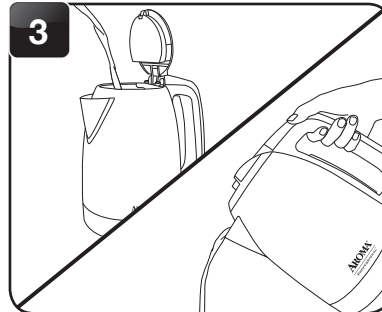

3 Rinse any remaining soapy water from the kettle. Drain.



NOTE

- Never attempt to disassemble the kettle or the power base.
- Never immerse the kettle, power cord, plug or power base in water.
- Always take care not to allow electrical components to come into contact with water.
- Do not use abrasive cleaners or scouring pads of any kind on the kettle or power base. This will cause damage to the finish and may create a risk of electrical shock.
- Any other servicing should be performed by Aroma® Housewares.



REMOVING MINERAL DEPOSITS

Hard water can leave mineral deposits that create scale build-up on the interior of the kettle. If mineral deposits occur, follow these steps:



1

Fill the kettle half full with water.

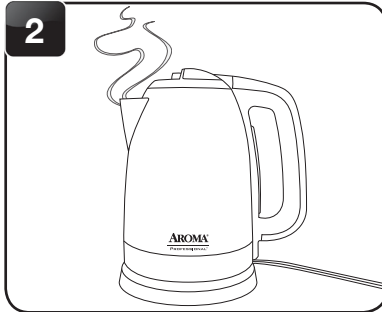

2

Following the instructions in "To Boil Water" on page 5, bring the water to a boil.



3

Add one cup of white vinegar to the water in the kettle.

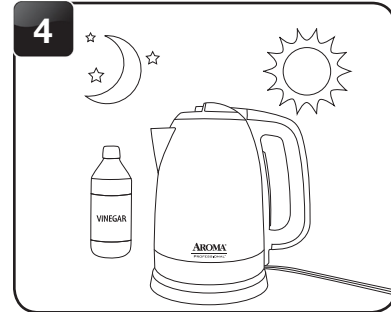

4

Allow the mixture to soak overnight.

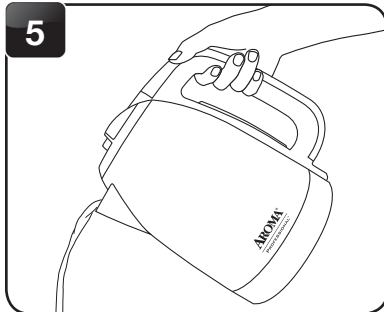

5

Empty the mixture and rinse out the kettle.

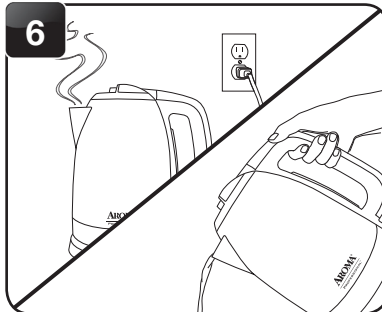

6

Refill the kettle with water only. Bring it to a boil and empty again. Repeat as needed.



HELPFUL
HINT

- Using distilled water will help to prevent the buildup of mineral deposits.



LIMITED WARRANTY

LIMITED WARRANTY

Aroma Housewares Company warrants this product free from defects in material and workmanship for five years from provable date of purchase in the United States.

Within this warranty period, Aroma Housewares Company will repair or replace, at its option, defective parts at no charge, provided the product is returned, freight prepaid with proof of purchase and U.S. \$15.00 for shipping and handling charges payable to Aroma Housewares Company. Before returning an item, please call the toll free number below for a return authorization number. Allow 2-4 weeks for return shipping.

This warranty does not cover improper installation, misuse, abuse or neglect on the part of the owner. Warranty is also invalid in any case that the product is taken apart or serviced by an unauthorized service station.

This warranty gives you specific legal rights, which may vary from state to state, and does not cover areas outside the United States.

AROMA HOUSEWARES COMPANY
6469 Flanders Drive
San Diego, California 92121
1-800-276-6286
M-F, 8:30 AM - 4:30 PM, Pacific Time
Website: www.AromaCo.com

SERVICE & SUPPORT

In the event of a warranty claim, or if service is required for this product, please contact Aroma® customer service toll-free at:

1-800-276-6286
M-F, 8:30AM-4:30PM, Pacific Time

Or we can be reached online at CustomerService@AromaCo.com.

For your records, we recommend stapling your sales receipt to this page along with a written record of the following:

Date of Purchase: _____

Place of Purchase: _____



NOTE

- Proof of purchase is required for all warranty claims.