

**General**

The following drawings are general diagrammatic examples only.  
Consult a certified heating professional for your specific application.

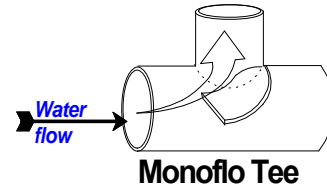
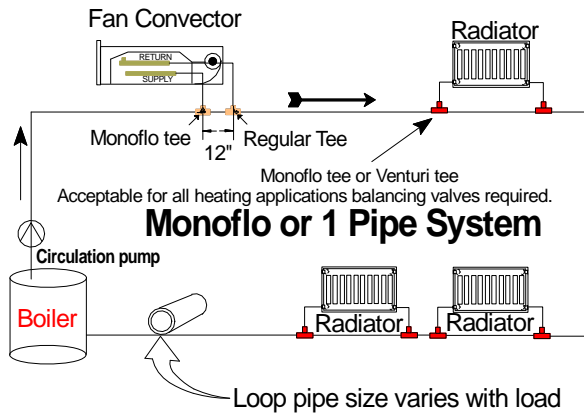

**General information on the use of Monoflo tees:**

- Scoop type is placed on the supply.
- Venturi Type on the return.
- If heating unit is below the main or more the 4 feet horizontally from the main use both scoop on the supply and a venturi on the return.

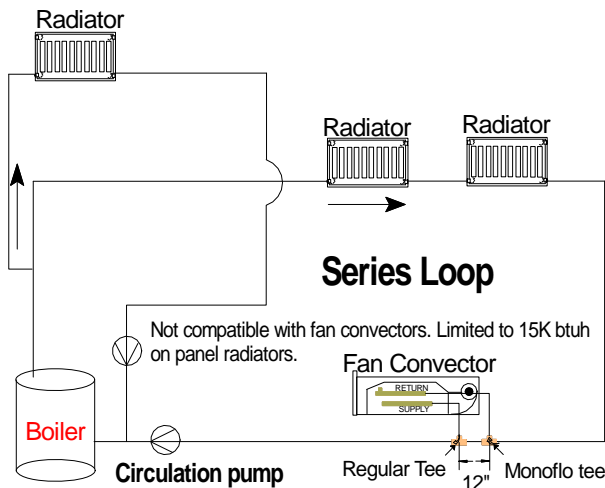

A single fan convector may be added to a series loop using monoflo tees.

