

TacoGenie™

Pre-Fab Easy Installation

For Models: 006-CT-USK, 008-CT-USK

Installation and Operating Instructions for Existing Homes with Standard Piping

Plant I.D. 001-1024

EFFECTIVE: November 1, 2014



Certified to
NSF/ANSI 372



TacoGenie™ is manufactured using the highest quality component parts available. Patented Integral Flow Checks (IFC) are built into each TacoGenie pump to prevent cold water from entering the hot water line. State-of-the-art electronics allow the TacoGenie to accurately sense temperature and automatically shut off the pump to maximize comfort and energy savings. TacoGenie saves energy and water. You can look forward to over 15 years of life expectancy with a TacoGenie.

taco-hvac.com



A Taco resource – saving product

Installation shall be in accordance with the manufacturer's instructions or warranty may be voided.

IMPORTANT

Operation of the TacoGenie without being plumbed into water lines may damage the pump and void the warranty.

WARNING: In the event the retaining screws have been pulled out of the housing, **DO NOT** replace them. Use of any other screw may short out the stator windings, creating a risk of electrical shock.

WARNING: To avoid electrical shock, disconnect the power supply to the circulator and the main electrical unit.

CAUTION: When installing electrical connections, do not apply mechanical loads to the capacitor box; otherwise, retaining screws may be pulled out of the housing, making circulator unusable.

PRE-INSTALLATION CHECKLIST

1. TacoGenie includes:

- Models 006-CT/006-CT-USK, 008-CT/008-CT-USK
- "00" Cartridge circulating pump with built-in TacoGenie electronics, power cord, Integral Flow Check (IFC) and mounting bracket
- Starter button
- Set of two (2) 1/2" plumbing adapter tees (included with "USK" models only)
- Set of two (2) 1/2" stainless steel flex lines (included with "USK" models only)

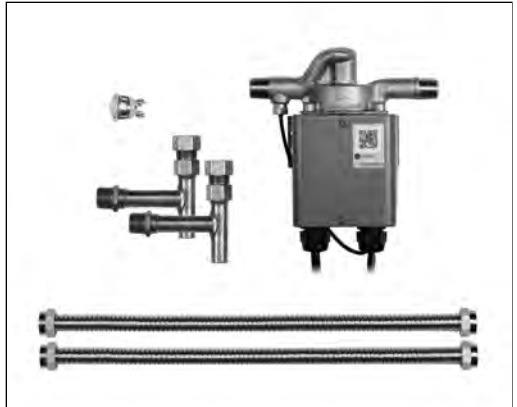

2. Tools you need:

- Pipe or crescent wrench
- Plier
- Wire strippers
- Phillips and flat head screwdrivers
- Drill and 5/8 inch drill bit

3. Best location for the TacoGenie:

Typically, this would be at the fixture farthest away from the water heater, generally the kitchen or master bath room. If your hot water supply runs in two different directions from the water heater, you may need more than one TacoGenie.

PUMP POSITION

Pump should always be installed in a horizontal position (as shown) with TacoGenie capacitor box facing up toward the sink. Be sure arrow on pump casing is pointing from left to right (hot water to cold water side) prior to connecting the flex lines. **Note:** T's and flex lines supplied by Taco provide maximum flow and performance. Alternative plumbing parts may restrict flow and delay hot water to fixtures.



INSTALLATION FOR THE CT-SERIES TACOGENIE MODELS 006-CT-USK AND 008-CT-USK

The two custom adapter "T"s are designed to simplify your installation to 1/2 inch copper hot and cold supply lines. If you have plumbing other than as shown in these instructions, additional fittings may be required. Consult a plumbing professional.



ELECTRICAL SUPPLY

A 110V electrical supply outlet is required to power the TacoGenie unit. If an outlet is not available, install a 110V outlet in accordance with all local electrical codes. **Caution: Do not plug in the TacoGenie until all plumbing and wiring connections are completed and water supply is turned on.** Running the circulating pump without water may damage internal components and void warranty.

PLUMBING INSTRUCTIONS USING USK- PLUMBING ADAPTER KIT

1. Turn off the house water supply at the main shut-off valve.
2. Open hot and cold faucets at the fixture chosen for installation. This will relieve water pressure from the hot and cold water lines.
3. Remove the hot and cold shut-off valve angle stops from the 1/2" copper pipes located below the sink. Be sure to use a catch basin to drain water from hot and cold lines. **Warning: To prevent scalding, use caution when removing valve on hot water line.** For ease of installation, leave the existing compression ring and nut from the angle stops on the hot and cold water lines.
4. Remove the compression ring and nut from the adapter tees provided and slide on to opposite straight copper end. Attach the existing nut and ring to the threaded end of the tee and tighten firmly.
5. Connect the shut-off valves to the new compression ring and nut and tighten firmly.
6. Attach the stainless steel flex lines to the 1/2" threaded connection on the tees and the 1/2" threaded connections on the pump. Teflon tape is recommended for the 1/2" threaded fittings.



1. Turn off water supply and remove angle stops.



2. Install tees and attach angle stops.



3. Connect flex lines to tees.

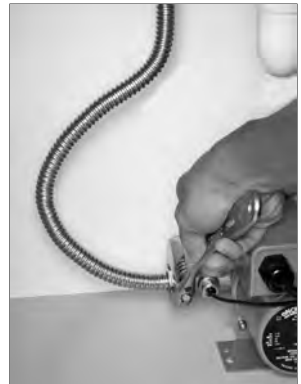

4. Connect flex lines to pump.

INSTALLING THE TACOGENIE STARTER BUTTON

The manual starter button is a unique feature to the TacoGenie. Using the manual start button maximizes energy savings and controls operation only when there is a request for hot water as compared to automatic timer controlled systems.

1. Drill a $\frac{5}{8}$ " hole into the desired location, typically the side or front of a vanity cabinet.
2. Insert the gray wire from the controller through the back side of the hole and connect it to the starter button.
3. Firmly insert the button into the drilled hole.

Note: To operate the TacoGenie from other locations throughout the house, additional starters can be installed and spliced into the gray wire provided. Or for wireless remote operation, the Taco #554-7 transmitter/receiver kit can be easily installed.

4. If wireless remote kit is not installed, use electrical tape or wire nuts to isolate the three leads (black, white and green) on the black wire.



COMPLETING YOUR INSTALLATION

1. Turn on the water supply at the main. Check the system carefully for possible leaks. If leaks occur, check all compression and threaded connections and tighten firmly. Open hot and cold fixtures for one to two minutes to flush system completely.
2. Plug in the TacoGenie to the 110V electrical outlet. The pump will start automatically the first time only and run for a short time until a rise in temperature is detected by the thermal sensor. Pump will automatically shut off. **Note: When the TacoGenie is operating a green LED located on the pump motor housing will illuminate. The Green LED will only be "on" when the pump is activated and circulating water.**
3. To test manual starter button, wait for hot water temperature to cool below 100°F (approximately 20-30 minutes). Press starter button to operate the pump. The TacoGenie should run for a short time and shut off automatically as in step 2 above.
4. Check hot water at the fixture for desired temperature. If hot water temperature is not satisfactory, refer to Trouble Shooting checklist section.

TROUBLESHOOTING – DIAGNOSING SPECIFIC PROBLEMS

PROBLEM	POSSIBLE CAUSE	REMEDY
1. The pump does not run when push button is pressed. Green LED does not illuminate.	A. No power at electrical outlet B. You've plugged the controller into an electrical outlet controlled by a wall switch, (such as the outlet under many kitchen sinks that controls the garbage disposal.)	• Plug the controller into a "hot" outlet
	C. Power cord is not secured to pump D. Wire to push button is not connected well	• Shut off power, then make sure wires have good contact
	E. The temperature setting is already sensing "hot" water so the pump is not being activated	• Call 1-401-942-8000 to reset sensitivity setting
2. The water is not hot enough.	A. Pump was installed with water flow going in the wrong direction B. There is something in the piping that has blocked the flow of water	• Check the arrows on the pump casing to make sure they point in the correct direction (see page 2) • Check the piping for obstruction
3. There is hot water at the cold water tap.	A. The water temperature sensor is loose or dislodged B. The temperature sensitivity setting now in place is too low, so the pump is not shutting down soon enough	• Check the connection of the water temperature sensor to make sure it is firmly attached to the plug and casing • Call 1-401-942-8000 for reset information
4. Water is not hot enough when pump shuts down.	A. The temperature sensitivity setting now in place is too high, and the pump is turning itself off too soon	• Call 1-401-942-8000 for reset information
5. There is hot water in the cold water lines only	A. The pump is installed backwards	• Reinstall the pump correctly

LIMITED WARRANTY STATEMENT

Taco, Inc. will repair or replace without charge (at the company's option) any Taco 00 Series circulator or circulator part which is proven defective under normal use within three (3) years from the date of manufacture.

In order to obtain service under this warranty, it is the responsibility of the purchaser to promptly notify the local Taco stocking distributor or Taco in writing and promptly deliver the subject product or part, delivery prepaid, to the stocking distributor. For assistance on warranty returns, the purchaser may either contact the local Taco stocking distributor or Taco. If the subject product or part contains no defect as covered in this warranty, the purchaser will be billed for parts and labor charges in effect at time of factory examination and repair.

Any Taco product or part not installed or operated in conformity with Taco instructions or which has been subject to misuse, misapplication, the addition of petroleum-based fluids or certain chemical additives to the systems, or other abuse, will not be covered by this warranty.

If in doubt as to whether a particular substance is suitable for use with a Taco product or part, or for any application restrictions, consult the applicable Taco instruction sheets or contact Taco at (401-942-8000).

Taco reserves the right to provide replacement products and parts which are substantially similar in design and functionally equivalent to the defective product or part. Taco reserves the right to make changes in details of design, construction, or arrangement of materials of its products without notification.

TACO OFFERS THIS WARRANTY IN LIEU OF ALL OTHER EXPRESS WARRANTIES. ANY WARRANTY IMPLIED BY LAW INCLUDING WARRANTIES OF MERCHANTABILITY OR FITNESS IS IN EFFECT ONLY FOR THE DURATION OF THE EXPRESS WARRANTY SET FORTH IN THE FIRST PARAGRAPH ABOVE.

THE ABOVE WARRANTIES ARE IN LIEU OF ALL OTHER WARRANTIES, EXPRESS OR STATUTORY, OR ANY OTHER WARRANTY OBLIGATION ON THE PART OF TACO.

TACO WILL NOT BE LIABLE FOR ANY SPECIAL, INCIDENTAL, INDIRECT OR CONSEQUENTIAL DAMAGES RESULTING FROM THE USE OF ITS PRODUCTS OR ANY INCIDENTAL COSTS OF REMOVING OR REPLACING DEFECTIVE PRODUCTS.

This warranty gives the purchaser specific rights, and the purchaser may have other rights which vary from state to state. Some states do not allow limitations on how long an implied warranty lasts or on the exclusion of incidental or consequential damages, so these limitations or exclusions may not apply to you.

Do your **best work.**

TACO, INC., 1160 Cranston Street, Cranston, RI 02920 Telephone: (401) 942-8000 FAX: (401) 942-2360

TACO (Canada), Ltd., 8450 Lawson Road, Unit #3, Milton, Ontario L9T 0J8
Telephone: 905/564-9422 FAX: 905/564-9436

Visit our web site at: <http://www.taco-hvac.com>

Printed in USA

Copyright 2014

TACO, Inc.