



# 2.5 Cu. Ft. Countertop Merchandiser ♦ NPCM25SB



Plug Type: (NEMA) 5-15P

### Technical Specifications

Product Classification	Refrigerator
Climate Class	N
Power	85W
Number of Doors / Lids	1
External Cabinet Material	Black Vinyl Coated Steel
Door Material	304 Stainless Steel
Type of Refrigeration Agent	R-134A
Type of Temperature Control	Digital
Temperature Range °C	1°C to 6°C
Temperature Range °F	34°F to 43°F
Voltage / Frequency	115V / 60Hz
Amp	1.3
Door Handle	Partial / Stainless Steel

### Standard Feature

- ♦ Interior LED Lighting with On/Off Switch
- ♦ Chrome Plated Shelves
- ♦ Stainless Steel, Self Closing Door
- ♦ Electronic Temperature Control with Digital Display
- ♦ Automatic Defrost
- ♦ Key Lock

### Accessories

Shelves	2 (Full) 1 (Half)
Fixed Shelves	No
Internal Light	Yes
Internal Light Switch	No
External Light Switch	Yes
Self Closing Door/Lid	Yes
Adjustable Thermostat	Yes

### Capacity

Capacity	2.5 cu. ft.
----------	-------------

### Dimensions

External Dimensions (W x D x H)	17 x 19 x 25 in
Shipping Dimensions (W x D x H)	21 x 23 x 29 in

### Weight

Net Weight	45 lbs.
Gross Weight	52 lbs.

### Certified Safety Standard

- ♦ ETL Listed
- ♦ ETL Sanitation Listed



### Warranty Information

- ♦ 5 Years Compressor
- ♦ 1 Year Parts & Labor







# 1 Reach-In Glass Door Refrigerator (Swing Door) ♦ NPGR1-S9B



## Standard Feature

- ♦ Bottom Mounted Compressor
- ♦ Functional Accessory / Control Shelves
- ♦ Removable Door Gasket
- ♦ Insulating Anti-Fog Glass Door
- ♦ Accurate Temperature Control
- ♦ Interior LED lighting

## Technical Specifications

Product Classification	Refrigerator
Climate Class	N
Power	667W
Number of Doors / Lids	1
External Cabinet Material	Coated Steel
Internal Cabinet Material	Aluminum Line with Steel Floor
Type of Refrigeration Agent	R-134A
Type of Temperature Control	Mechanical
Temperature Range °C	0°C to 5°C
Temperature Range °F	32°F to 41°F
Voltage / Frequency	115V / 60Hz
Amp	5.8
Compressor HP	1/4+ HP
Type of Insulation	3.0-inch Polyurethane Foam
Door Handle	Partial

## Certified Safety Standard

- ♦ ETL Listed
- ♦ ETL Sanitation Listed



## Warranty Information

- ♦ 5 Years Compressor
- ♦ 3 Year Parts & Labor





# 1 Reach-In Glass Door Refrigerator (Swing Door) ♦ NPGR1-S9B

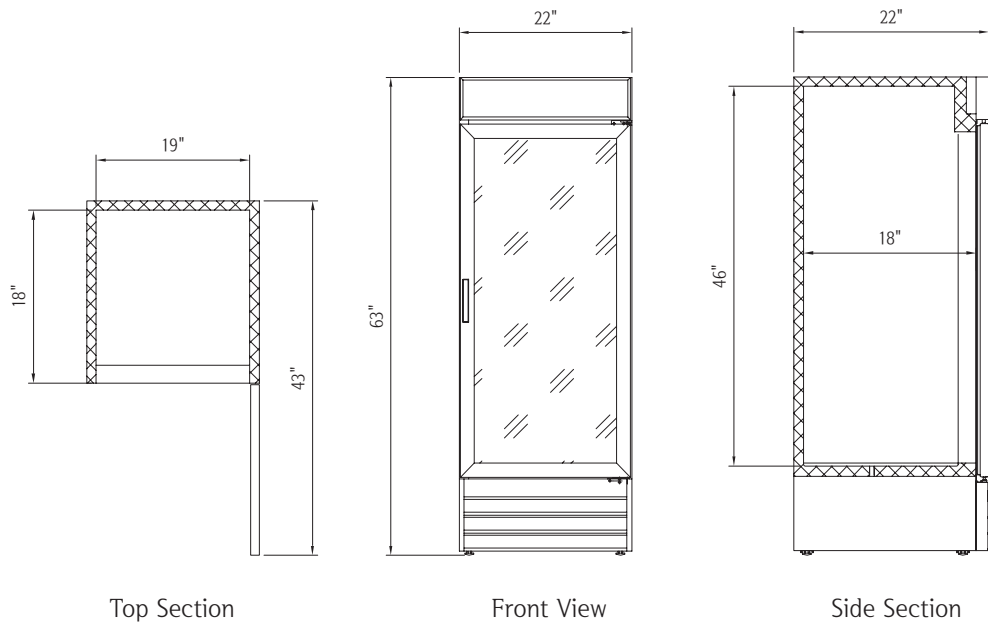

Plug Type: (NEMA) 5-15P

## Capacity

Capacity 9 cu. ft.

## Dimensions

Internal Cabinet Width	19 in
Internal Cabinet Depth	18 in
Internal Cabinet Height	46 in
External Width	22 in
External Depth	22 in
External Height	63 in
Shipping Dimensions (W x D x H)	26 x 26 x 68 in

## Weight

Gross Weight 161 lbs.

## Accessories

Frost Free	Yes
Adjustable Shelves	4
Fixed Shelves	No
Internal Light	Yes
Internal Light Switch	No
External Light Switch	No
Self Closing Door/Lid	Yes
Adjustable Thermostat	Yes



# 1 Reach-In Glass Door Refrigerator (Swing Door) ♦ NPGR1-SB



## Standard Feature

- ♦ Bottom Mounted Compressor
- ♦ Functional Accessory / Control Shelves
- ♦ Removable Door Gasket
- ♦ Insulating Anti-Fog Glass Door
- ♦ Accurate Temperature Control
- ♦ Interior LED lighting
- ♦ Heavy-duty caster wheels

## Technical Specifications

Product Classification	Refrigerator
Climate Class	N
Power	989W
Number of Doors / Lids	1
External Cabinet Material	Coated Steel
Internal Cabinet Material	Aluminum Line with Steel Floor
Type of Refrigeration Agent	R-134A
Type of Temperature Control	Mechanical
Temperature Range °C	0°C to 5°C
Temperature Range °F	32°F to 41°F
Voltage / Frequency	115V / 60Hz
Amp	8.6
Compressor HP	1/3+ HP
Type of Insulation	High Density Polyurethane Foam
Door Handle	Partial

## Certified Safety Standard

- ♦ ETL Listed
- ♦ ETL Sanitation Listed



## Warranty Information

- ♦ 5 Years Compressor
- ♦ 3 Year Parts & Labor





# 1 Reach-In Glass Door Refrigerator (Swing Door) ♦ NPGR1-SB

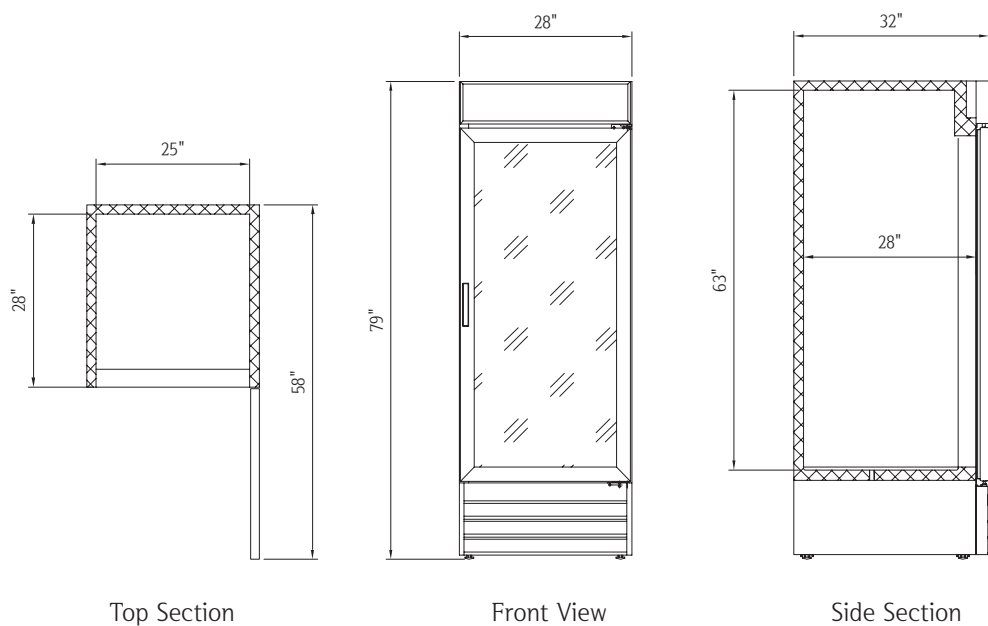

Plug Type: (NEMA) 5-15P

## Capacity

Capacity 23 cu. ft.

## Dimensions

Internal Cabinet Width	25 in
Internal Cabinet Depth	28 in
Internal Cabinet Height	63 in
External Width	28 in
External Depth	32 in
External Height	79 in
Shipping Dimensions (W x D x H)	31 x 35 x 85 in

## Weight

Gross Weight 328 lbs.

## Accessories

Frost Free	Yes
Adjustable Shelves	4
Fixed Shelves	No
Internal Light	Yes
Internal Light Switch	No
External Light Switch	No
Self Closing Door/Lid	Yes
Adjustable Thermostat	Yes



## 2 Reach-In Glass Door Refrigerator (Swing Door) ♦ NPGR2-SB



### Standard Feature

- ♦ Bottom Mounted Compressor
- ♦ Functional Accessory / Control Shelves
- ♦ Removable Door Gasket
- ♦ Insulating Anti-Fog Glass Door
- ♦ Accurate Temperature Control
- ♦ Interior LED lighting
- ♦ Heavy-duty caster wheels

### Technical Specifications

Product Classification	Refrigerator
Climate Class	N
Power	1162W
Number of Doors / Lids	2
External Cabinet Material	Coated Steel
Internal Cabinet Material	Aluminum Liner with Steel Floor
Type of Refrigeration Agent	R-134A
Type of Temperature Control	Digital
Temperature Range °C	0°C to 5°C
Temperature Range °F	32°F to 41°F
Voltage / Frequency	115V / 60Hz
Amp	10.1
Compressor HP	1/2+ HP
Type of Insulation	2.5-Inch Polyurethane Foam
Door Handle	Partial

### Certified Safety Standard

- ♦ ETL Listed
- ♦ ETL Sanitation Listed



### Warranty Information

- ♦ 5 Years Compressor
- ♦ 3 Year Parts & Labor





## 2 Glass Swing Door Merchandiser ♦ NPGR2-SB

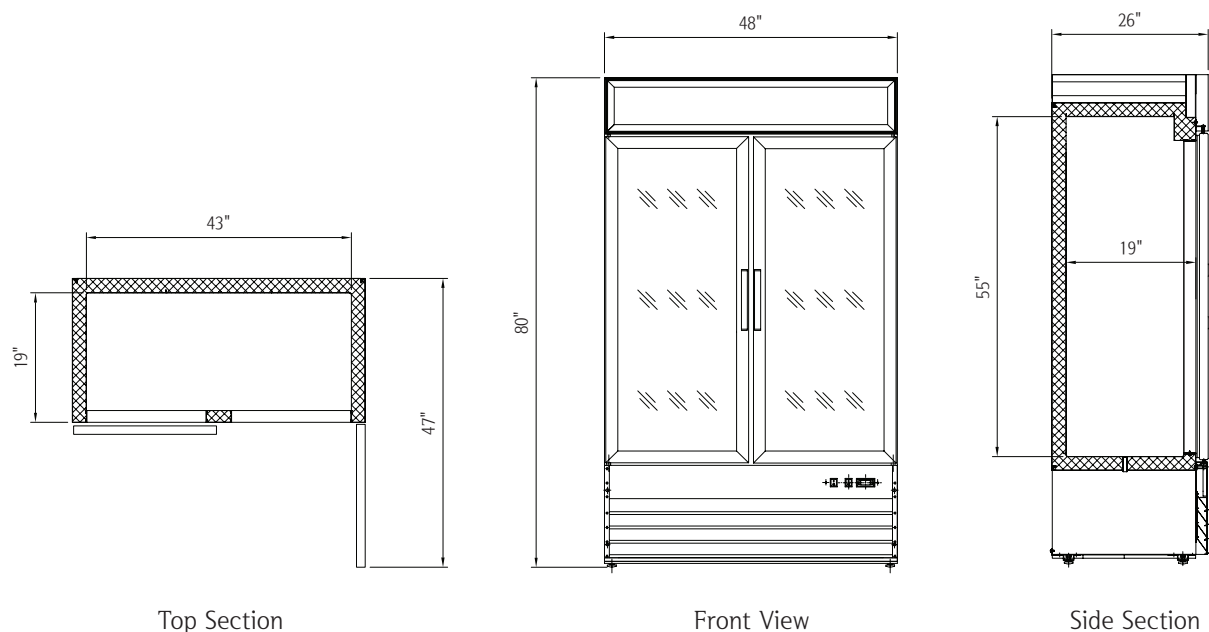

Plug Type: (NEMA) 5-15P

### Capacity

Capacity 29 cu. ft.

### Dimensions

Internal Cabinet Width	43 in
Internal Cabinet Depth	19 in
Internal Cabinet Height	55 in
External Width	48 in
External Depth	26 in
External Height	80 in
Shipping Dimensions (W x D x H)	51 x 30 x 87 in

### Weight

Gross Weight 564 lbs.

### Accessories

Frost Free	Yes
Adjustable Shelves	8
Fixed Shelves	No
Internal Light	Yes
Internal Light Switch	No
External Light Switch	No
Self Closing Door/Lid	Yes
Adjustable Thermostat	Yes



# norpole

## 2 Reach-In Glass Door Refrigerator (Swing Door) ♦ NPGR2-S45B



### Standard Feature

- ♦ Bottom Mounted Compressor
- ♦ Functional Accessory / Control Shelves
- ♦ Removable Door Gasket
- ♦ Insulating Anti-Fog Glass Door
- ♦ Accurate Temperature Control
- ♦ Interior LED lighting
- ♦ Heavy-duty caster wheels

### Technical Specifications

Product Classification	Refrigerator
Climate Class	N
Power	1058W
Number of Doors / Lids	2
External Cabinet Material	Coated Steel
Internal Cabinet Material	Aluminum Liner with Steel Floor
Type of Refrigeration Agent	R-134A
Type of Temperature Control	Digital
Temperature Range °C	0°C to 5°C
Temperature Range °F	32°F to 41°F
Voltage / Frequency	115V / 60Hz
Amp	9.2
Compressor HP	3/4 HP
Type of Insulation	3.0-Inch Polyurethane Foam
Door Handle	Partial

### Certified Safety Standard

- ♦ ETL Listed
- ♦ ETL Sanitation Listed



### Warranty Information

- ♦ 5 Years Compressor
- ♦ 3 Year Parts & Labor





## 2 Reach-In Glass Door Refrigerator (Swing Door) ♦ NPGR2-S45B

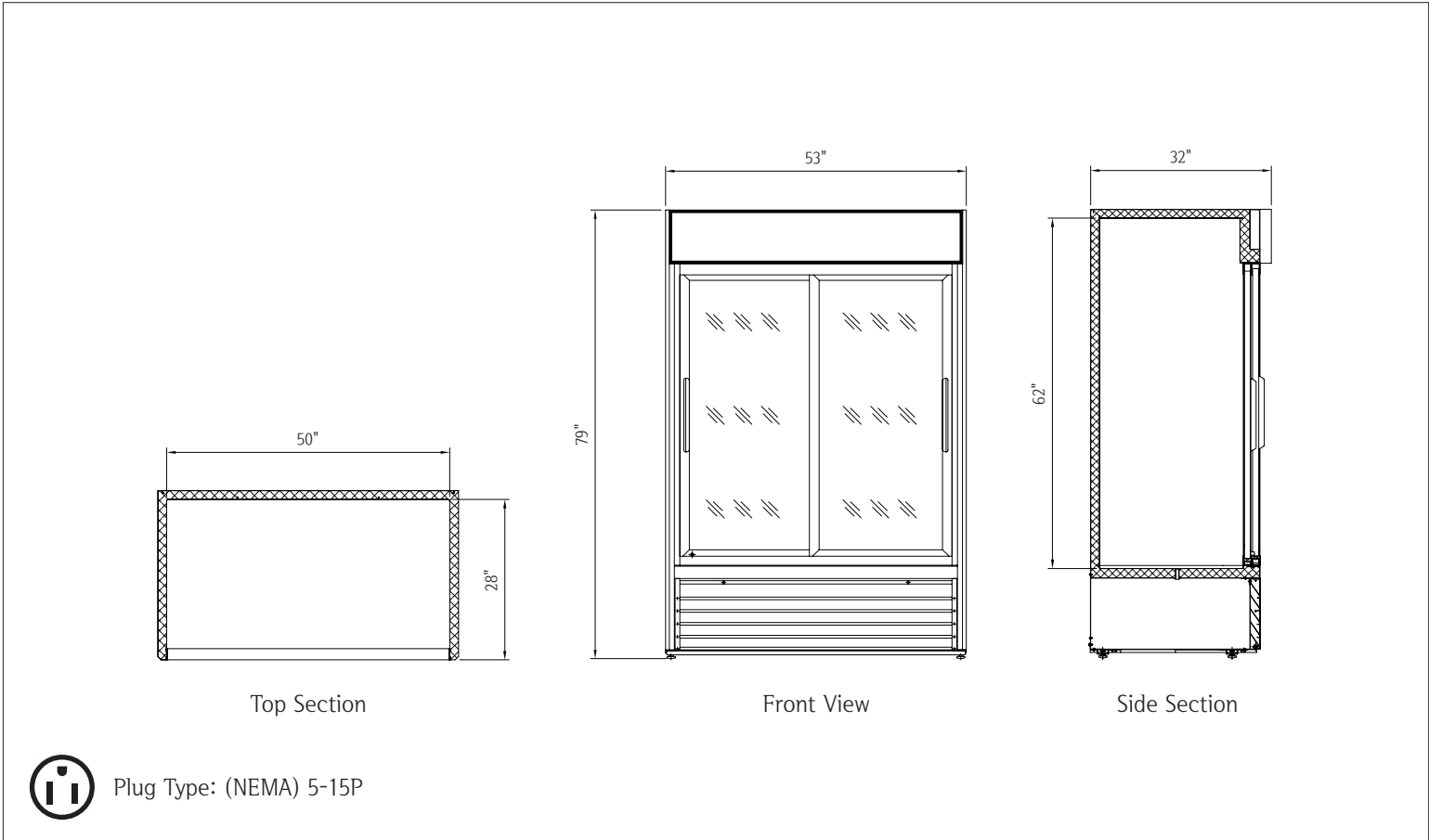

Capacity	
Capacity	45 cu. ft.

Dimensions	
Internal Cabinet Width	50 in
Internal Cabinet Depth	28 in
Internal Cabinet Height	62 in
External Width	53 in
External Depth	32 in
External Height	79 in
Shipping Dimensions (W x D x H)	56 x 33 x 84 in

Weight	
Net Weight	441 lbs.
Gross Weight	485 lbs.

Accessories	
Adjustable Shelves	8
Fixed Shelves	No
Internal Light	Yes
Internal Light Switch	No
External Light Switch	Yes
Self Closing Door/Lid	Yes
Adjustable Thermostat	Yes

# norpole

## 3 Reach-In Glass Door Refrigerator (Swing Door) ♦ NPGR3-SB



### Standard Feature

- ♦ Bottom Mounted Compressor
- ♦ Functional Accessory / Control Shelves
- ♦ Removable Door Gasket
- ♦ Insulating Anti-Fog Glass Door
- ♦ Accurate Temperature Control
- ♦ Interior LED lighting
- ♦ Heavy-duty caster wheels

### Technical Specifications

Product Classification	Refrigerator
Climate Class	N
Power	1668W
Number of Doors / Lids	3
External Cabinet Material	Coated Steel
Internal Cabinet Material	Aluminum Liner with Steel Floor
Type of Refrigeration Agent	R-134A
Type of Temperature Control	Digital
Temperature Range °C	0°C to 5°C
Temperature Range °F	32°F to 41°F
Voltage / Frequency	115V / 60Hz
Amp	14.5
Compressor HP	3/4+ HP
Type of Insulation	High Density Polyurethane Foam
Door Handle	Partial

### Certified Safety Standard

- ♦ ETL Listed
- ♦ ETL Sanitation Listed



### Warranty Information

- ♦ 5 Years Compressor
- ♦ 3 Year Parts & Labor





# 3 Reach-In Glass Door Refrigerator (Swing Door) ♦ NPGR3-SB

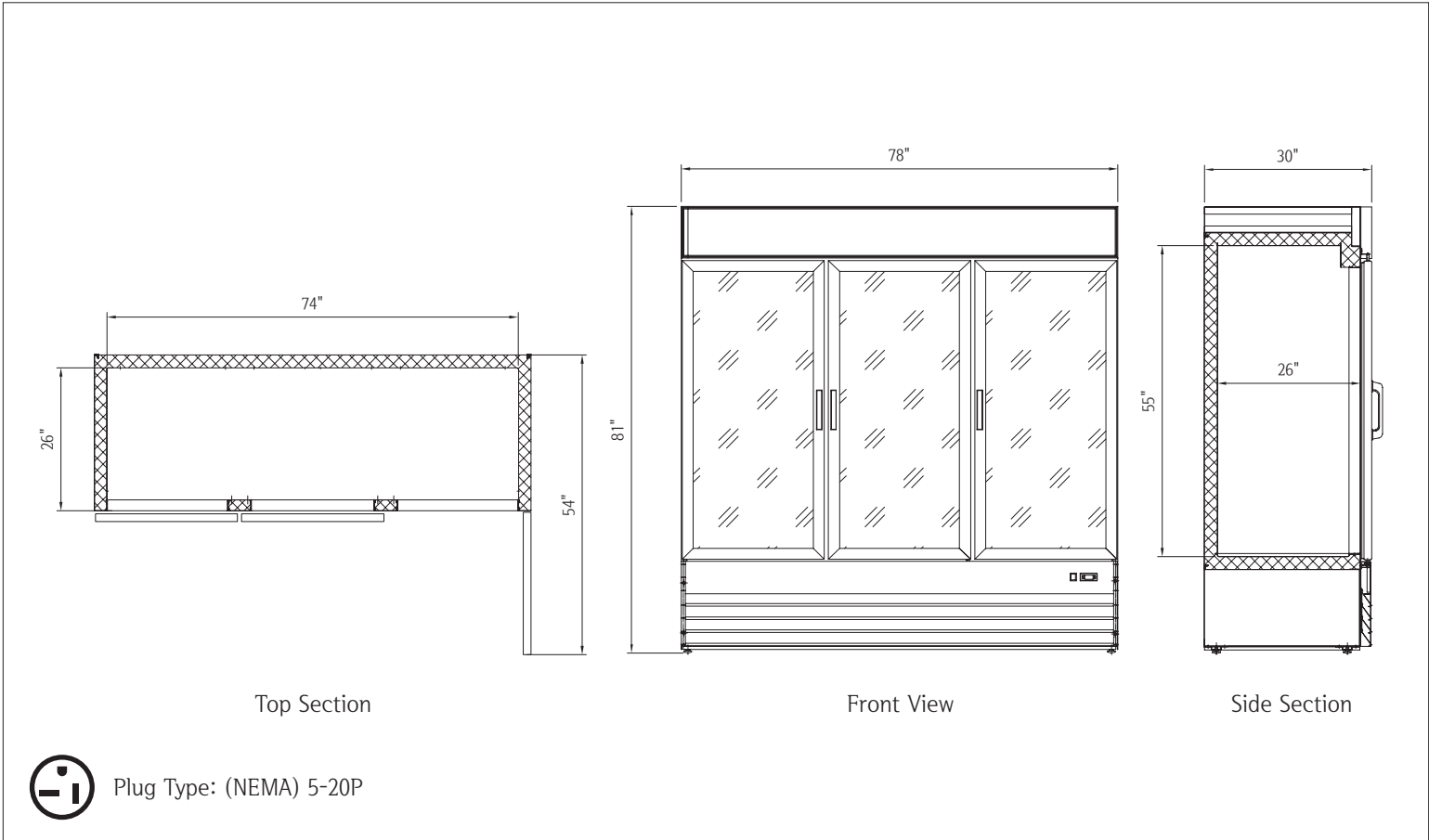

## Capacity

Capacity 53 cu. ft.

## Dimensions

Internal Cabinet Width	73 in
Internal Cabinet Depth	26 in
Internal Cabinet Height	55 in
External Width	78 in
External Depth	30 in
External Height	81 in
Shipping Dimensions (W x D x H)	80 x 33 x 83 in

## Weight

Gross Weight 840 lbs.

## Accessories

Frost Free	Yes
Adjustable Shelves	12
Fixed Shelves	No
Internal Light	Yes
Internal Light Switch	No
External Light Switch	No
Self Closing Door/Lid	Yes
Adjustable Thermostat	Yes



# 1 Reach-In Glass Door Freezer (Swing Door) ♦ NPGF1-S13



## Standard Feature

- ♦ Bottom Mounted Compressor
- ♦ Functional Accessory / Control Shelves
- ♦ Removable Door Gasket
- ♦ Insulating Anti-Fog Glass Door
- ♦ Accurate Temperature Control
- ♦ Interior LED lighting
- ♦ Heavy-duty caster wheels

## Technical Specifications

Product Classification	Freezer
Climate Class	N
Power	1208W
Number of Doors / Lids	1
External Cabinet Material	Coated Steel
Internal Cabinet Material	Aluminum Liner with Steel Floor
Type of Refrigeration Agent	R-404A
Type of Temperature Control	Digital
Temperature Range °C	-23°C to -18°C
Temperature Range °F	-10°F to 0°F
Voltage / Frequency	115V / 60Hz
Amp	10.5
Compressor HP	3/4+ HP
Type of Insulation	3.0-Inch Polyurethane Foam
Door Handle	Partial

## Certified Safety Standard

- ♦ ETL Listed
- ♦ ETL Sanitation Listed



## Warranty Information

- ♦ 5 Years Compressor
- ♦ 3 Year Parts & Labor





# 1 Reach-In Glass Door Freezer (Swing Door) ♦ NPGF1-S13

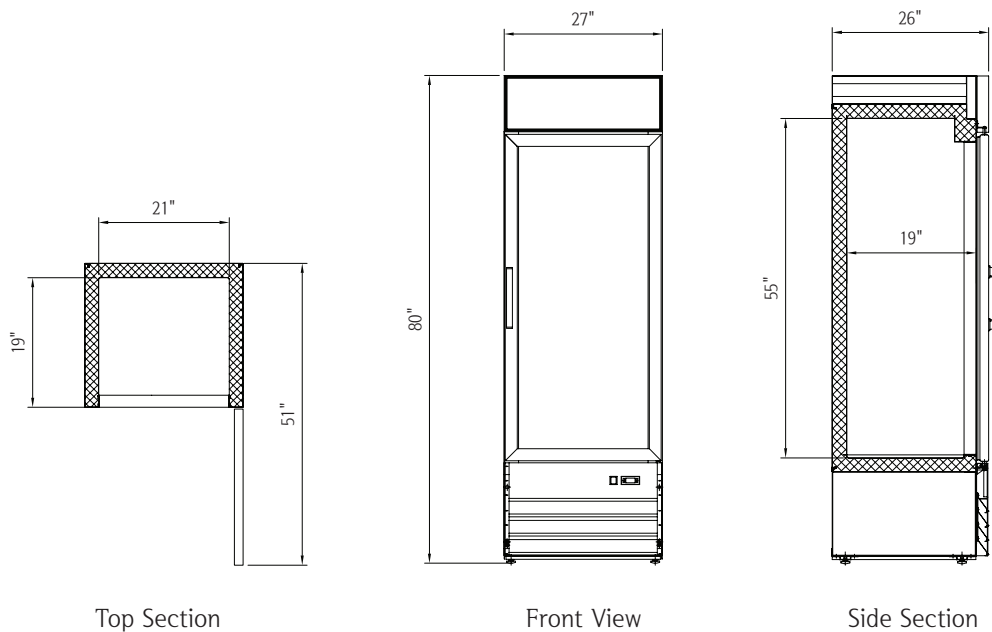

Plug Type: (NEMA) 5-15P

## Capacity

Capacity 13 cu. ft.

## Dimensions

Internal Cabinet Width	21 in
Internal Cabinet Depth	19 in
Internal Cabinet Height	55 in
External Width	27 in
External Depth	26 in
External Height	80 in
Shipping Dimensions (W x D x H)	30 x 30 x 87 in

## Weight

Gross Weight 361 lbs.

## Accessories

Cycle Defrosting	Yes
Frost Free	Yes
Adjustable Shelves	4
Fixed Shelves	No
Internal Light	Yes
Internal Light Switch	No
External Light Switch	No
Self Closing Door/Lid	Yes
Adjustable Thermostat	Yes



# 1 Reach-In Glass Door Freezer (Swing Door) ♦ NPGF1-SB



NPGF1-S ▶

## Standard Feature

- ♦ Bottom Mounted Compressor
- ♦ Functional Accessory / Control Shelves
- ♦ Removable Door Gasket
- ♦ Insulating Anti-Fog Glass Door
- ♦ Accurate Temperature Control
- ♦ Interior LED lighting
- ♦ Heavy-duty caster wheels

## Technical Specifications

Product Classification	Freezer
Climate Class	N
Power	1104W
Number of Doors / Lids	1
External Cabinet Material	Coated Steel
Internal Cabinet Material	Aluminum Liner with Steel Floor
Type of Refrigeration Agent	R-404A
Type of Temperature Control	Digital
Temperature Range °C	-23°C to -18°C
Temperature Range °F	-10°F to 0°F
Voltage / Frequency	115V / 60Hz
Amp	9.6
Compressor HP	3/4+ HP
Type of Insulation	3.0-Inch Polyurethane Foam
Door Handle	Partial

## Certified Safety Standard

- ♦ ETL Listed
- ♦ ETL Sanitation Listed



## Warranty Information

- ♦ 5 Years Compressor
- ♦ 3 Year Parts & Labor





# 1 Reach-In Glass Door Freezer (Swing Door) ♦ NPGF1-SB

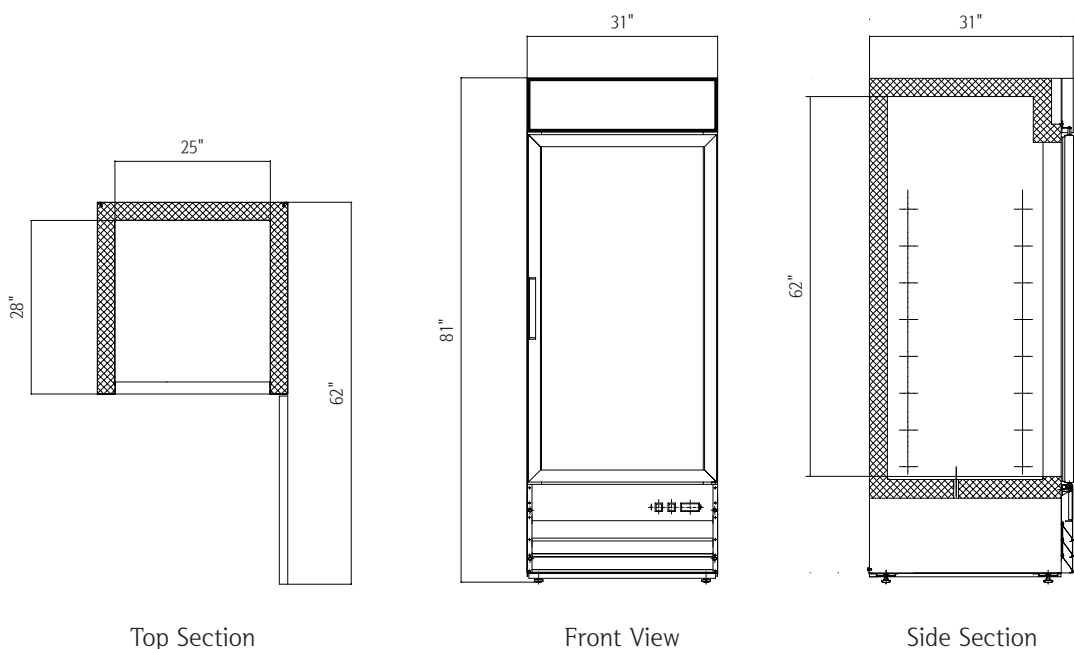

Plug Type: (NEMA) 5-15P

## Capacity

Capacity 23 cu. ft.

## Dimensions

Internal Cabinet Width	25 in
Internal Cabinet Depth	28 in
Internal Cabinet Height	62 in
External Width	31 in
External Depth	31 in
External Height	81 in
Shipping Dimensions (W x D x H)	33 x 37 x 89 in

## Weight

Gross Weight 551 lbs.

## Accessories

Cycle Defrosting	Yes
Frost Free	Yes
Adjustable Shelves	4
Fixed Shelves	No
Internal Light	Yes
Internal Light Switch	No
External Light Switch	No
Self Closing Door/Lid	Yes
Adjustable Thermostat	Yes





## 2 Reach-In Glass Door Freezer (Swing Door) ♦ NPGF2-SB



NPGF2-S ▶

### Standard Feature

- ♦ Bottom Mounted Compressor
- ♦ Functional Accessory / Control Shelves
- ♦ Removable Door Gasket
- ♦ Insulating Anti-Fog Glass Door
- ♦ Accurate Temperature Control
- ♦ Interior LED lighting
- ♦ Heavy-duty caster wheels

### Technical Specifications

Product Classification	Freezer
Climate Class	N
Power	1725W
Number of Doors / Lids	2
External Cabinet Material	Coated Steel
Internal Cabinet Material	Aluminum Liner with Steel Floor
Type of Refrigeration Agent	R-404A
Type of Temperature Control	Digital
Temperature Range °C	-23°C to -18°C
Temperature Range °F	-10°F to 0°F
Voltage / Frequency	115V / 60Hz
Amp	15
Compressor HP	1 HP
Type of Insulation	3.0-Inch Polyurethane Foam
Door Handle	Partial

### Certified Safety Standard

- ♦ ETL Listed
- ♦ ETL Sanitation Listed



### Warranty Information

- ♦ 5 Years Compressor
- ♦ 3 Year Parts & Labor





## 2 Reach-In Glass Door Freezer (Swing Door) ♦ NPGF2-SB

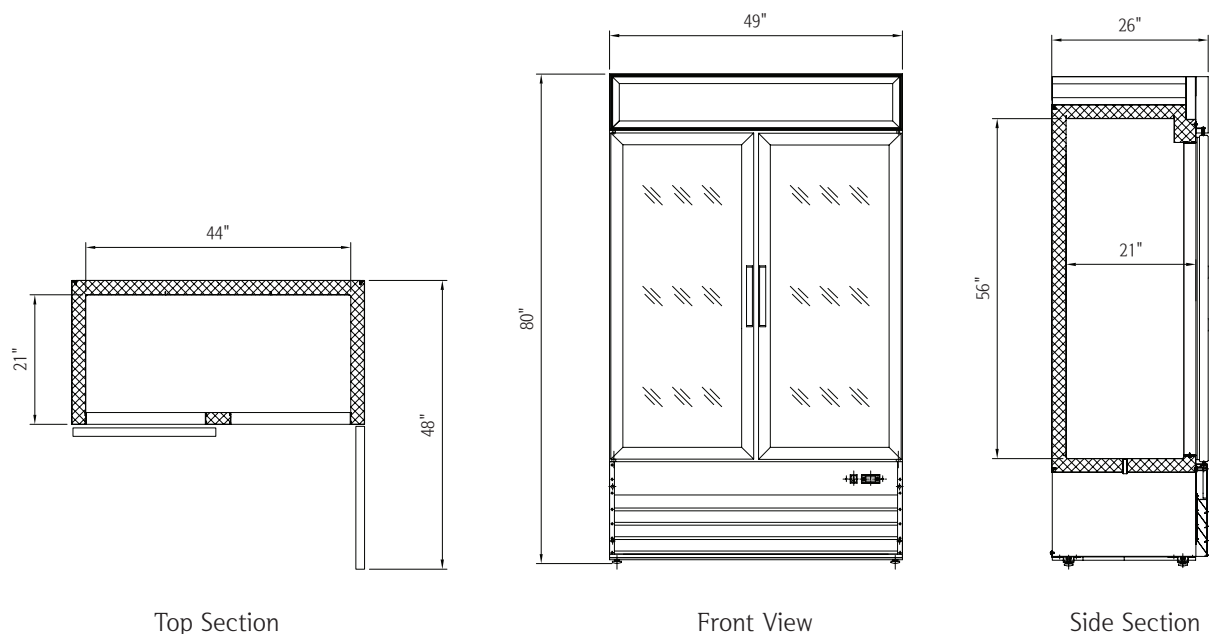

Plug Type: (NEMA) 5-20P

### Capacity

Capacity 29 cu. ft.

### Dimensions

Internal Cabinet Width 44 in  
 Internal Cabinet Depth 21 in  
 Internal Cabinet Height 56 in  
 External Width 49 in  
 External Depth 26 in  
 External Height 80 in  
 Shipping Dimensions (W x D x H) 52 x 30 x 87 in

### Weight

Gross Weight 606 lbs.

### Accessories

Cycle Defrosting Yes  
 Frost Free Yes  
 Adjustable Shelves 8  
 Fixed Shelves No  
 Internal Light Yes  
 Internal Light Switch No  
 External Light Switch No  
 Self Closing Door/Lid Yes  
 Adjustable Thermostat Yes



## 2 Reach-In Glass Door Freezer (Swing Door) ♦ NPGF2-S45B



NPGF2-S45 ▶

### Standard Feature

- ♦ Bottom Mounted Compressor
- ♦ Functional Accessory / Control Shelves
- ♦ Removable Door Gasket
- ♦ Insulating Anti-Fog Glass Door
- ♦ Accurate Temperature Control
- ♦ Interior LED lighting
- ♦ Heavy-duty caster wheels

### Technical Specifications

Product Classification	Freezer
Climate Class	N
Power	1656W
Number of Doors / Lids	2
External Cabinet Material	Coated Steel
Internal Cabinet Material	Aluminum Liner with Steel Floor
Type of Refrigeration Agent	R-404A
Type of Temperature Control	Digital
Temperature Range °C	-23°C to -18°C
Temperature Range °F	-10°F to 0°F
Voltage / Frequency	115V / 60Hz
Amp	14.4
Compressor HP	1-1/4 HP
Type of Insulation	3.0-Inch Polyurethane Foam
Door Handle	Partial

### Certified Safety Standard

- ♦ ETL Listed
- ♦ ETL Sanitation Listed



### Warranty Information

- ♦ 5 Years Compressor
- ♦ 3 Year Parts & Labor





## 2 Reach-In Glass Door Freezer (Swing Door) ♦ NPGF2-S45B

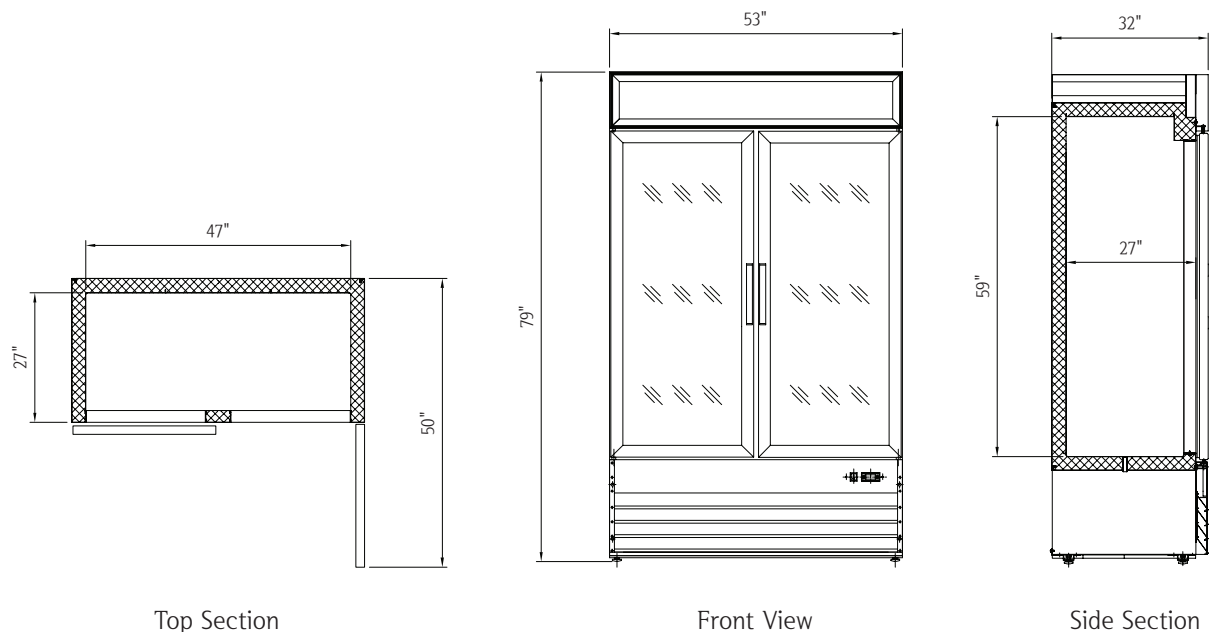

Plug Type: (NEMA) 5-20P

### Capacity

Capacity 45 cu. ft.

### Dimensions

Internal Cabinet Width	47 in
Internal Cabinet Depth	27 in
Internal Cabinet Height	59 in
External Width	53 in
External Depth	32 in
External Height	79 in
Shipping Dimensions (W x D x H)	56 x 33 x 84 in

### Weight

Net Weight	573 lbs.
Gross Weight	617 lbs.

### Accessories

Frost Free	Yes
Adjustable Shelves	8
Fixed Shelves	No
Internal Light	Yes
Internal Light Switch	No
External Light Switch	Yes
Self Closing Door/Lid	Yes
Adjustable Thermostat	Yes



## 3 Reach-In Glass Door Freezer (Swing Door) ♦ NPGF3-SB



NPGF3-S ▶

### Standard Feature

- ♦ Bottom Mounted Compressor
- ♦ Functional Accessory / Control Shelves
- ♦ Removable Door Gasket
- ♦ Insulating Anti-Fog Glass Door
- ♦ Accurate Temperature Control
- ♦ Interior LED lighting
- ♦ Heavy-duty caster wheels

### Technical Specifications

Product Classification	Freezer
Climate Class	N
Power	2358W
Number of Doors / Lids	3
External Cabinet Material	Coated Steel
Internal Cabinet Material	Aluminum Liner with Steel Floor
Type of Refrigeration Agent	R-404A
Type of Temperature Control	Digital
Temperature Range °C	-23°C to -18°C
Temperature Range °F	-10°F to 0°F
Voltage / Frequency	115V / 60Hz
Amp	20.5
Compressor HP	(2) 3/4+ HP
Type of Insulation	3.0-Inch Polyurethane Foam
Door Handle	Partial

### Certified Safety Standard

- ♦ ETL Listed
- ♦ ETL Sanitation Listed



### Warranty Information

- ♦ 5 Years Compressor
- ♦ 3 Year Parts & Labor





## 3 Reach-In Glass Door Freezer (Swing Door) ♦ NPGF3-SB

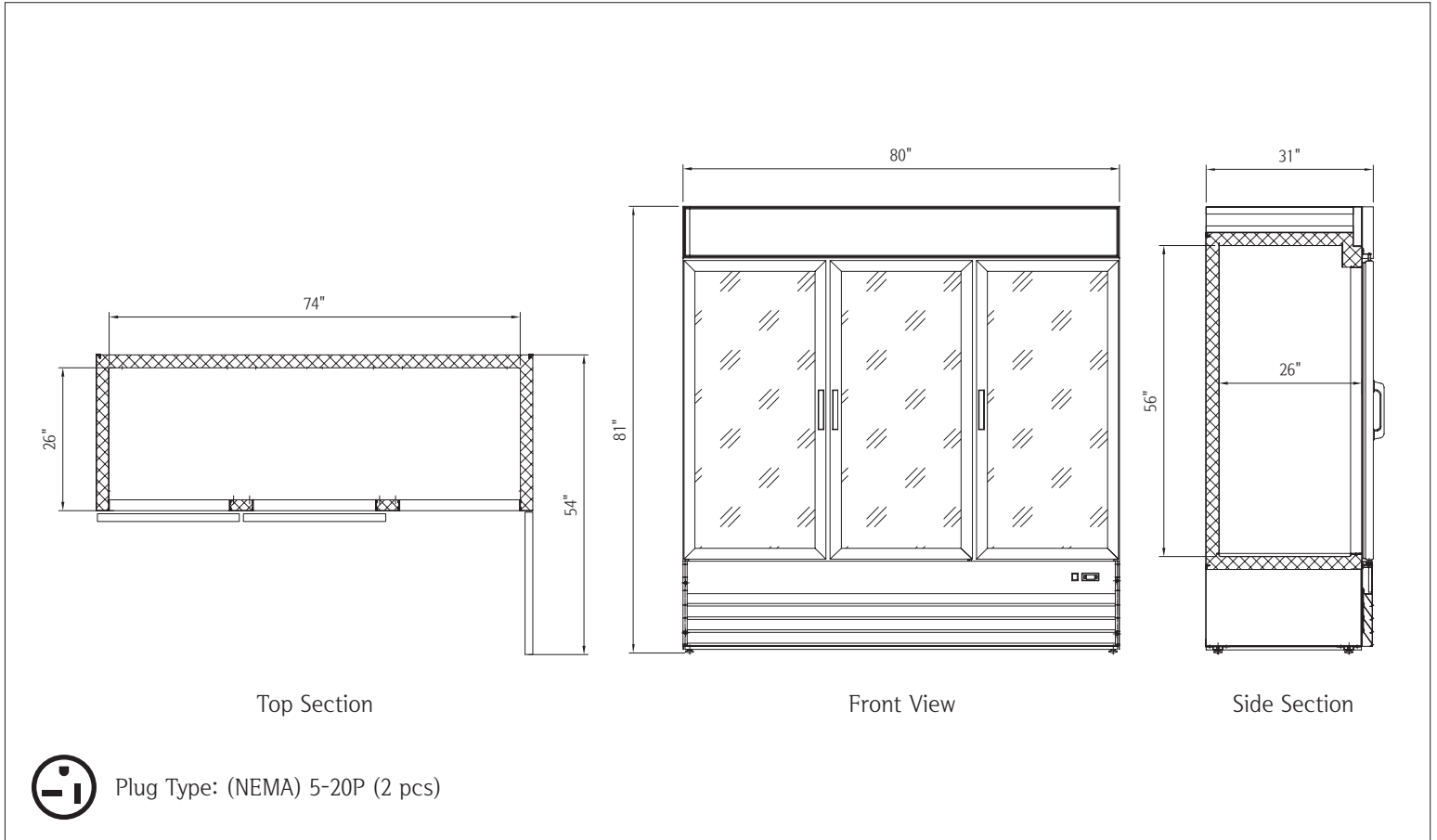

### Capacity

Capacity 52 cu. ft.

### Dimensions

Internal Cabinet Width 74 in

Internal Cabinet Depth 26 in

Internal Cabinet Height 56 in

External Width 80 in

External Depth 31 in

External Height 81 in

Shipping Dimensions (W x D x H) 83 x 33 x 85 in

### Weight

Gross Weight 870 lbs.

### Accessories

Cycle Defrosting Yes

Frost Free Yes

Adjustable Shelves 12

Fixed Shelves No

Internal Light Yes

Internal Light Switch No

External Light Switch No

Self Closing Door/Lid Yes

Adjustable Thermostat Yes



## 2 Reach-In Glass Door Refrigerator (Slide Door) ♦ NPGR2-B



NPGR2 ▶

### Standard Feature

- ♦ Bottom Mounted Compressor
- ♦ Functional Accessory / Control Shelves
- ♦ Removable Door Gasket
- ♦ Insulating Anti-Fog Glass Door
- ♦ Accurate Temperature Control
- ♦ Interior LED lighting
- ♦ Heavy-duty caster wheels

### Technical Specifications

Product Classification	Refrigerator
Climate Class	N
Power	1058W
Number of Doors / Lids	2
External Cabinet Material	Coated Steel
Internal Cabinet Material	Aluminum Liner with Steel Floor
Type of Refrigeration Agent	R-134A
Type of Temperature Control	Mechanical
Temperature Range °C	0°C to 5°C
Temperature Range °F	32°F to 41°F
Voltage / Frequency	115V / 60Hz
Amp	9.2
Compressor HP	1/2+ HP
Type of Insulation	High Density Polyurethane Foam
Door Handle	Partial

### Certified Safety Standard

- ♦ ETL Listed
- ♦ ETL Sanitation Listed



### Warranty Information

- ♦ 5 Years Compressor
- ♦ 3 Year Parts & Labor







## 2 Reach-In Glass Door Refrigerator (Slide Door) ♦ NPGR2-B

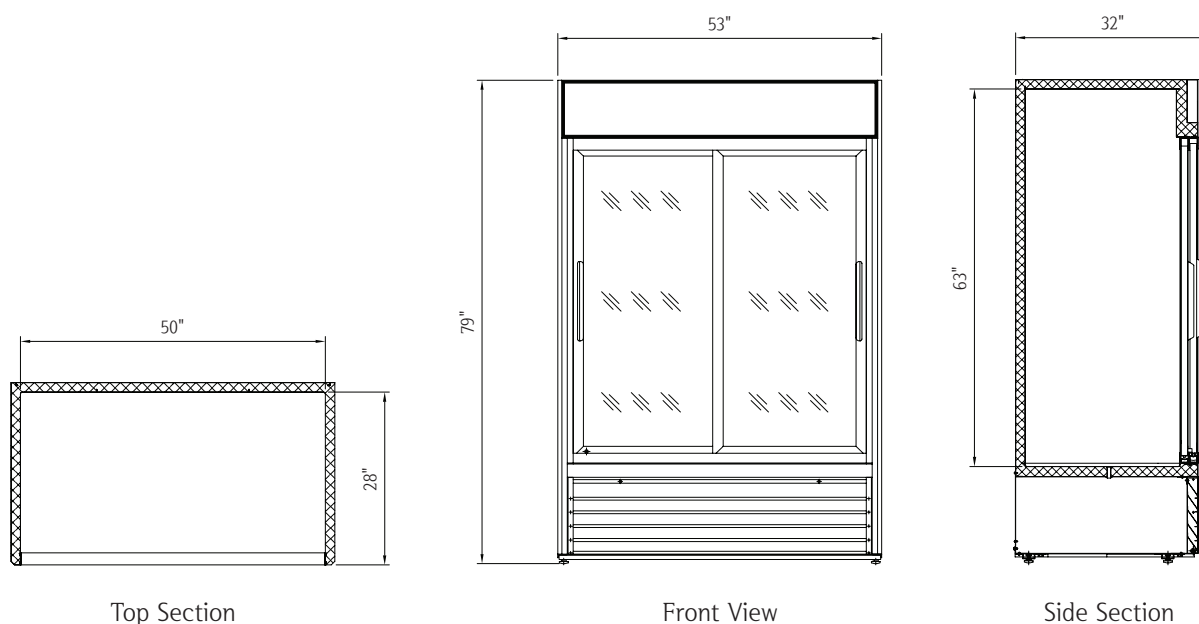

Plug Type: (NEMA) 5-15P

### Capacity

Capacity 45 cu. ft.

### Dimensions

Internal Cabinet Width	50 in
Internal Cabinet Depth	28 in
Internal Cabinet Height	63 in
External Width	53 in
External Depth	32 in
External Height	79 in
Shipping Dimensions (W x D x H)	56 x 33 x 84 in

### Weight

Gross Weight 580 lbs.

### Accessories

Frost Free	Yes
Adjustable Shelves	8
Fixed Shelves	No
Internal Light	Yes
Internal Light Switch	No
External Light Switch	No
Self Closing Door/Lid	Yes
Adjustable Thermostat	Yes