

# USING YOUR REFRIGERATOR

## ADJUSTING CONTROL SETTINGS

Give the refrigerator time to cool down completely before adding food. It is best to wait 24 hours before adding food to the refrigerator. The mid-settings indicated in the previous section should be correct for normal household refrigerator usage. The controls are set correctly when milk or juice is cold to your liking and ice cream is firm.

The refrigerator control functions as the thermostat for the entire appliance. The higher the number setting, the longer the compressor will run to keep the temperature colder. The freezer control adjusts the cold air flow from the freezer to the refrigerator. Setting the freezer control to a lower temperature keeps more cold air in the freezer compartment to make it colder.

If you need to adjust the temperature in the refrigerator or freezer, begin by adjusting the refrigerator first. Wait 24 hours after the refrigerator adjustment to check the freezer temperature. If it is too warm or too cold, then adjust the freezer control as well.

Use the settings listed in the table below as a guide.

CONDITION/REASON:	RECOMMENDED ADJUSTMENT:
<b>REFRIGERATOR section is too warm</b> <ul style="list-style-type: none"> <li>Opening the door often</li> <li>Adding a large amount of food</li> <li>Room temperature is very warm</li> </ul>	<b>Adjust the REFRIGERATOR setting to the next highest number and wait 24 hours, then check.</b>
<b>FREEZER section is too warm/ ice is made too slowly</b> <ul style="list-style-type: none"> <li>Opening the door often</li> <li>Adding a large amount of food</li> <li>Room temperature is very low (not cycling often enough)</li> <li>Using ice frequently</li> <li>Air vents blocked by objects</li> </ul>	<b>Adjust the FREEZER setting to the next highest number and wait 24 hours, then check.</b>  <b>Remove any objects blocking air flow.</b>
<b>REFRIGERATOR section is too cold</b> <ul style="list-style-type: none"> <li>Controls not set correctly for your conditions</li> </ul>	<b>Adjust the REFRIGERATOR setting to the next lowest number and wait 24 hours, then check.</b>
<b>FREEZER section is too cold</b> <ul style="list-style-type: none"> <li>Controls not set correctly for your conditions</li> </ul>	<b>Adjust the FREEZER setting to the next lowest number and wait 24 hours, then check.</b>

## FOOD STORAGE GUIDE

ITEMS	HOW TO STORE
<b>Storing Fresh Food</b>	Wrap or store food in the refrigerator in airtight and moisture-proof material unless otherwise noted. This prevents food odor and taste transfer throughout the refrigerator. For dated products, check date code to ensure freshness.
<b>Butter or margarine</b>	Store opened butter in a covered dish or in a closed compartment. When storing a larger quantity, wrap in freezer packing and freeze.
<b>Cheese</b>	Store in original packaging until you are ready to use it. Once opened, tightly rewrap with plastic wrap or aluminum foil.
<b>Vegetables with skins (carrots, peppers)</b>	Place in bags or plastic containers inside the crisper.
<b>Fruit</b>	Wash and let dry; store in plastic bags in the refrigerator. Do not wash or pit berries until you are ready to eat them. Berries should be selected and kept in their original packaging (if there is any) or in a paper bag closed halfway and set on a shelf.
<b>Leafy Vegetables</b>	Remove original packaging and trim any dirty or discolored parts. Wash in cold water and drain. Place in a plastic bag or plastic container and store in the crisper.
<b>Fish</b>	Consume fish or seafood the same day purchased.
<b>Chef Fresh</b>	Store any meat in original airtight, moisture-proof packaging. Rewrap if necessary.
<b>Leftovers</b>	Cover leftovers with plastic wrap or aluminum foil. Plastic containers with airtight lids can also be used.

## USING YOUR REFRIGERATOR

### Packaging Recommendations:

- Use sealed plastic containers.
- Use plastic containers with a smooth surface.
- Package with aluminum foil of high resistance.
- Wrap with paper layered with plastic.
- Use water proof plastic.
- Use recommended plastic bags to store frozen foods.

Follow these packaging or container instructions in order to reach the best freezing

### Do not use:

- Bread Wrapping.
- Plastic container not safe for storing.
- Containers without lids or seals.
- Waxed paper or waxed plastic.
- Thin wrapping paper or not water proof.

### Freezing

**IMPORTANT:** Do not keep bottles in the freezer compartment, they may explode after freezing and cause damage.

For the maximum use of your freezer do not store excess food. Do not introduce a large amount of unfrozen foods that cannot be frozen within 24 hours (no more than 2 – 3 pounds or ,91 kg - 1,36 kg of food per square inch of space in the freezer). Sufficient space must be left in order for the air to circulate properly around the packages. Leave enough space in order to close your refrigerator with out difficulty.

Storage times can vary depending on the type and quality of the food, the way its package, or packaging container used, (in comparison to air and humidity), and the temperature it being stored in. Ice crystals formed inside your package are normal it indicates the air and humidity inside your package have condensed.

**NOTE:** Let warm foods cool off at room temperature for approximately 30 min, then wrap accordingly with the methods mention above and freeze. By letting your warm foods cool off before you introduce them to your freezer it will save you energy.

### WARNING

#### SUFFOCATING DANGER

Adequate ventilation is required when using dry ice. Dry ice is Carbon Dioxide (CO<sub>2</sub>). When it evaporates it produces oxygen, causing dizziness, slight headaches, unconsciousness or death. Do not inhale these vapors and properly ventilate the room while in use of dry ice.

# USING YOUR REFRIGERATOR

## REFRIGERATOR SHELVES

The glass shelves in your refrigerator are adjustable to meet your individual storage needs.

Adjusting the shelves to fit different heights of items will make finding the exact item you want easier. Doing so will also reduce the amount of time the refrigerator door is open which will save energy.

**IMPORTANT:** Do not clean glass shelves with warm water while they are cold. Shelves may break if exposed to sudden temperature changes or impact.

**NOTE:** Glass shelves are heavy. Use special care when removing them.

### Adjusting Shelves

Remove shelves from the shipping position and replace shelves in the position you want.

To remove a shelf—Tilt up the back of the shelf in the direction of 1 and lift it in the direction of 2. Pull the shelf out.

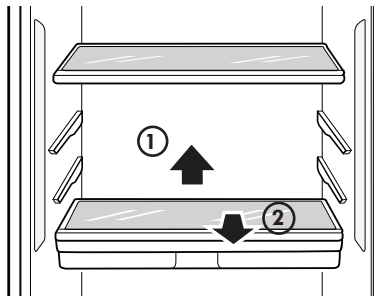

To reinstall a shelf—Slide the shelf into the guides until it stops.

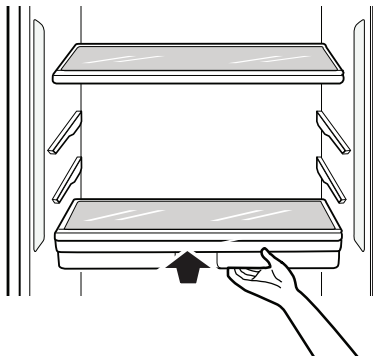

## PANTRY DRAWER (on some models)

To remove the Pantry Drawer:

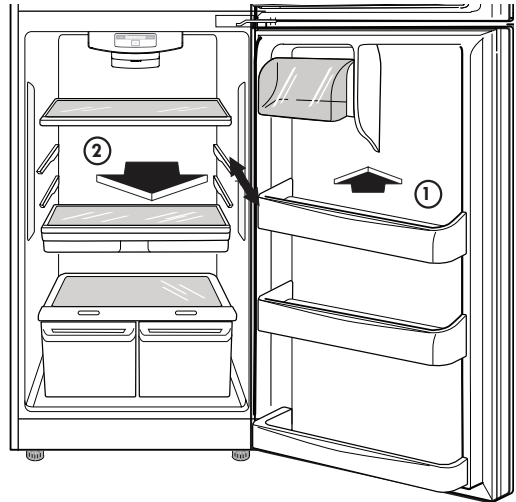

Grasp the drawer handle and pull it forward to the drawer stop. Lift up and pull out.

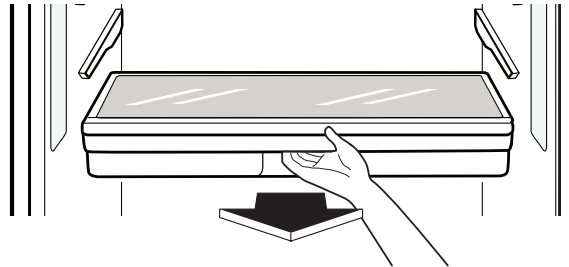

### To replace the Pantry Drawer:

Slide the drawer back all the way past the drawer stop.

### Ice Tray (On some models)

- Pour potable water to the level indicated in the picture. Do not overfill with water or ice cubes will be difficult to remove
- For quick freeze, adjust the freezer dial to 3.

### Twist the ice tray to remove the ice cubes

- Do not bend the ice tray. Doing so may result in damage to the tray.
- To remove ice cubes easily, pour water on the back of the tray or soak it in water before removing ice cubes.



# USING YOUR REFRIGERATOR

## HUMIDITY CONTROLLED CRISPERS

The crispers provide fresher tasting fruit and vegetables by letting you easily control humidity inside the drawer.

You can control the amount of humidity in the moisturesealed crispers by adjusting the control to any setting between **VEGETABLES** and **FRUIT**.

- **VEGETABLES** keeps moist air in the crisper for best storage of fresh, leafy vegetables.
- **FRUIT** lets moist air out of the crisper for best storage of fruit.

### To remove and install the crisper drawers:

1. Pull the crisper drawer out to the drawer stop.
2. Lift the front of the crisper up, then pull it straight out.
3. To install, slightly tilt up the front, insert the drawer into the frame and push it back into place, past the drawer stop.

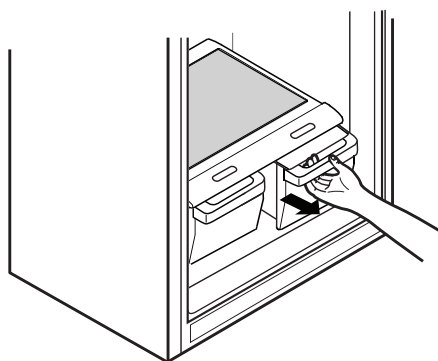

### To remove the crisper glass:

1. Remove the crisper drawers (as described above).
2. Reach in under the glass and lift up.
3. Gently push the glass up and out.

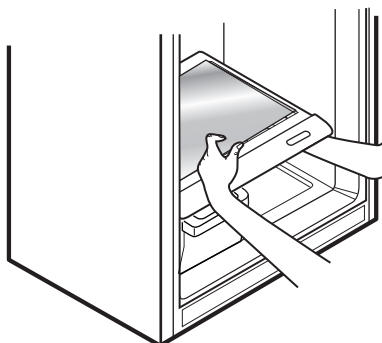

### To remove the crisper cover:

1. Remove both crisper drawers.
2. Remove the crisper glass.
3. While holding the support and crisper cover, pull up and out.

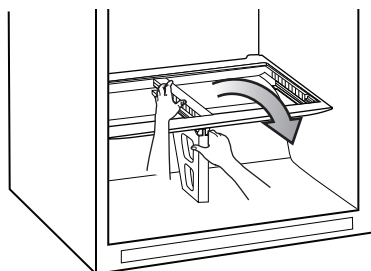

## DOOR BINS

The door bins are removable for easy cleaning and adjustment.

1. To remove the bin, simply lift the bin up and pull straight out.

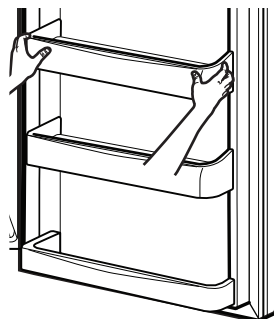

2. To replace the bin, slide it in above the desired support and push down until it snaps into place.

NOTE: Some bins may vary in appearance and will only fit in one location.

## DAIRY BIN

1. To remove the Dairy Bin, simply lift up and pull out.
2. To replace the Dairy Bin, slide it in above the desired support slots and push down until it stops.

