

## Models 445FS Pneumatic PowerStapler™



### OPERATION AND MAINTENANCE MANUAL MANUAL DE OPERACION Y DE MANTENIMIENTO MANUEL D'INSTRUCTIONS ET D'ENTRETIEN

#### WARNING



Read this manual before you use this PowerStapler®. Follow all safety warnings and instructions. If you are uncertain about the operation of the stapler, call us directly at 1-800-323-1653 for assistance or contact the closest Powernail Dealer for help. Please retain this information for future reference.

# **INTRODUCTION**

The PowerStapler® Model 445FS Mallet Actuated Pneumatic Stapler is designed to bring Powernail quality to a pneumatic stapler. For those looking for ease of use in a pneumatic tool, the PowerStapler Model 445FS provides several distinct advantages. The Model 445FS can staple 3/4" flooring down to 1/2" tongue and groove hardwood flooring through the use of easy-to-change, no-mar adapter plates. The Model 445FS is designed for use with 1-1/2", 1-3/4" and 2" PowerStaples®.

## **INDEX**

Index.....	2	Seal Locations Diagram.....	10
Warranty.....	2	Schematic .....	11
Safety Instructions.....	3	Safety Labels.....	12
Operating Instructions.....	4	Troubleshooting Chart.....	13
Parts & Service.....	4-7	Depth Chart.....	14
Drive Blade Change .....	5	Accessory Products.....	15
Seal Replacement.....	5-7	Powernail Company Info.....	16
Parts List.....	8-9		

## **LIMITED WARRANTY**

POWERNAIL® Company, Inc. warrants to its customer, and to the first end-use purchaser of POWERNAIL flooring nailers purchased from an authorized POWERNAIL distributor, that each serialized manufactured nailer by POWERNAIL®, for a period of 12 months from the date of purchase, and with respect to the nailer/stapler body (specifically Models 200, 445, and 50P), for a period of 10 years from date of purchase, (“warranty period”); shall be free of defects in materials and workmanship and will meet POWERNAIL’s specifications in effect at the time of Product shipment. POWERNAIL will repair or replace, at its option, any Powernailer® that does not conform to this warranty. Claims must be made no later than fifteen (15) days after the end of the warranty period. POWERNAIL will perform all repair or replacements itself or through its authorized contractors. POWERNAIL is not responsible for shipping, labor or other direct or indirect costs. Damage caused by abuse, misuse, unusual or excessive wear is excluded. Repair or modification of the Products by unauthorized parties will void this warranty. The customer is responsible for returning Products to POWERNAIL for verification of nonconformance. Warranties for Products not manufactured by POWERNAIL are limited to warranties provided to POWERNAIL by the manufacturer of such product that are assignable to customer.

THESE WARRANTIES AND REMEDIES ARE EXCLUSIVE OF ALL OTHERS, EXPRESS OR IMPLIED. THE WARRANTIES OF MERCHANTABILITY AND FITNESS FOR PURPOSE ARE EXPRESSLY EXCLUDED. IN NO EVENT SHALL POWERNAIL’S LIABILITY FOR A WARRANTY CLAIM EXCEED THE PRICE PAID TO POWERNAIL FOR THE NONCONFORMING PRODUCT, REGARDLESS OF THE FORM OR BASIS OF THE CLAIM OR CAUSE OF ACTION.

## **SAFETY INSTRUCTIONS**



Always use approved **SAFETY GLASSES** and **EAR PROTECTION** when operating this stapler. The operator and others in the work area should always wear approved **FRONT** and **SIDE** eye protection when operating this stapler. Eye protection will help guard against flying staples and debris, which could cause severe eye injury.



**EYE AND EAR PROTECTION** should be used to prevent hearing damage when there are high noise levels in the work area.

**ALWAYS** use ear plugs with a noise reduction rated at 29 db or higher at a construction site.

Stapler noise ratings are at LPA-1sd=90.6,

LWA-1sd=99.3 and LPA-1s,1m=86.3.

Stapler vibration rating:  $m/s^2=3.05$ .

Always **DISCONNECT THE AIR SUPPLY** before making any adjustments, repairing, clearing jams or when the stapler is not in use. Do not use on scaffolding or ladders and disconnect stapler from air supply when transporting between installation areas.

Never attach the female end of a quick disconnect to the stapler. This will trap air inside the Stapler and permit it to be discharged. Only the unrestricted male connection should be attached to the Stapler.

Stapler requires an air source that can continuously deliver 80 to 110 psi at 3-1/2 cubic feet of air per minute for operation.

Normal air pressure should not exceed 120 psi or damage to the Stapler and seals may occur. Excess air pressure can cause the Stapler to explode.

To prevent fire or explosion, use only regulated compressed air—do not use bottled gases of any kind (no oxygen or combustible gasses) to power this Stapler.

Stapler is intended for use installing wood flooring and is not to be used for purposes not specified in the operations manual.

The trigger is a safety device and should only be pulled when the Stapler is in proper Position on the work surface and before the plunger is struck with the mallet. Do not tie or tape down the safety trigger as the Stapler could discharge if dropped on the plunger. The Stapler will not fire unless the trigger is pulled before the mallet blow. Do not use the trigger safety as a lock up for the plunger then rack the wood using the locked up Stapler body. It will severely damage the Mechanism and the Stapler. Use the mallet to rack the wood strip, not the Stapler.

Do not use any nails other than Powernail Powercleats Nails which are specifically designed for use in any Powerstapler. Powercleats Nails are available in various lengths. Contact your Powernail Dealer for Powercleats Nails.

Use only Powernail replacement parts in the repair or maintenance of this stapler. Parts or repair services are available from the manufacturer or from agents authorised by the manufacturer. Repairs should be carried out only by trained service personnel in the field of fastener driving tools who will observe proper safety controls while performing maintenance. Service personnel should be qualified to assess the safe working condition of fastener driving tools.



Never place any part of the body in the discharge path of the Stapler when air is connected to the Stapler. Always make sure Stapler is empty of cleats before connecting air hose so as to prevent any accidental discharge from occurring.

Never leave the Stapler unattended while it is connected to an air supply.

Whenever air is connected to the Stapler, keep body parts away from the nail discharge path. Disconnect the air line before making adjustments or repairs on the Stapler. Only connect air to an unloaded Stapler so as to prevent accidental discharge.

**POWERNAIL COMPANY, INC.**

**1300 Rose Road, Lake Zurich, IL 60047 US**

**Phone: 1-800-323-1653 OR 847-847-3000**

**[www.powernail.com](http://www.powernail.com)**

# OPERATING INSTRUCTIONS

Consult the staple depth chart for the appropriate adapter pad to use with the thickness of flooring you are installing and the selection of Powercleat® length.

Rack the flooring into place with the rubber end of the mallet supplied with the Stapler.

Place the Stapler Adapter Foot on the tongue-edge of the flooring strip to be stapled. Be sure the Adapter Foot is pressed tightly against the edge of the flooring strip above the tongue.

Be sure flooring strips are racked tightly. Pull the Safety Trigger and tap the Stapler Plunger Rubber Cap with the rubber capped end of the mallet to discharge the Stapler.

**WARNING:** It is not necessary to hit the Stapler hard to activate it. Never hit the Stapler with excessive force or with the metal end of the mallet, this will damage the Stapler.

**DO NOT USE THE METAL END OF THE MALLET TO STRIKE THE PLUNGER,** use the rubber capped end only.

Never use the Safety Trigger interlock to lock up the plunger and rack the wood with blows to the Stapler body. This will severely damage the safety mechanism and Stapler. This abuse and damage is not covered by the warranty.

Before each use, check all screws to be sure they are tight. Shock and vibration can loosen screws. Do not over tighten any screw.

## **AIR SUPPLY:**

The air must be clean and dry. Dirty and/or wet air will damage the Stapler.

Drywall Dust:

- Using Pneumatic PowerStaplers in drywall dust conditions will dramatically decrease the life of the Stapler.
- Drywall dust is abrasive, when cycled through the Stapler it will cause excessive wear.

The air source must continuously deliver 80 to 110 psi at 3-1/2 cubic feet of air per minute to operate the Stapler. For operation, connect a 1/4" minimum internal diameter and clean air hose to the Stapler. Be sure the air regulator is set at 90 psi. If the staple is not countersunk below the surface of the wood, turn up the air pressure, but not over 110 psi.

Check for air supply leaks that waste air and starve the Stapler of air thereby reducing its performance. There should be no orifice smaller than 1/4" in the air path between the Regulator and the Stapler.

## **LUBRICATION:**

You must lubricate the Stapler manually. The

frequency of lubrication is dependent upon the duty cycle of the Stapler. Continuous duty requires more frequent oiling than intermittent duty.

At least every eight (8) hours place two to four drops of Air Tool Oil, supplied with your Stapler, into the disconnected air line male connector attached to the Stapler.

**WARNING:** Do not over lubricate the Stapler, excess oil mist or drops will be vented with spent air when over lubricated. Excess oil could stain the wood flooring, walls or furnishings. Dry fire the Stapler, without staples, to purge excess oil, before you begin to staple down flooring. Before storing the Stapler, lubricate and cycle the Stapler in insure internal parts are oil protected from corrosion.

**WARNING:** Detergent oil is not recommended and may damage the seals.

## **TO LOAD MODEL 445FS:**

Place two sticks (90 PowerStaples) into the Staple Channel feed slot. Pull back the spring loaded Staple Pusher over the staples until it contacts the last staple and slowly release the Staple Pusher.

## **TO UNLOAD MODEL 445FS:**

To remove staples from the Staple Channel, pull the two round knobs on the Staple Pusher together. This will clear it from the staple path. Then turn the Stapler over so the staples slide out of the channel.

## **PARTS & SERVICE:**

When ordering parts include the part number, part description, PowerStapler model and serial number. Be sure to state the quantity of the part(s) required. Contact your Powerstaple Dealer for the necessary parts.

**WARNING:** Never work on the Stapler if the air line is attached. Always disconnect the air line from the Stapler first.

## OPERATING INSTRUCTIONS, continued

### **Stapler DISASSEMBLY:**

#### **TO REPLACE RUBBER BUMPER (#20 or #65):**

1. Disconnect the air supply
2. Remove the four (4) cap screws holding the Adapter Foot, Foot and Staple Channel assembly to the main Body (see illustration).
3. Pull the Rubber Bumper out of the cylinder bore. Replace the old Bumper if it shows signs of wear or it is split.
4. Reverse these steps to reassemble the Stapler. Be sure to align the Driving Blade with the slot in the Staple Channel Assembly while you reassemble the Stapler.

NEVER FIRE THE Stapler WITHOUT THE RUBBER BUMPER INSTALLED, IT WILL SEVERELY DAMAGE THE STAPLER.

#### **CHANGING A DRIVING BLADE (#14):**

1. Disconnect the air supply.
2. Remove the four socket head cap screws(49) holding the Adapter Foot(6), Foot(7) and Staple Channel Assembly(42) to the body.
3. Remove the Rubber Bumper(20).
4. Pull the Driving Blade(14) with pliers until the Piston(10) is fully extended outward towards the bottom of the cylinder.
5. Use a 15/16" box wrench (Part #: 09-445-29768) to unscrew the Driving Blade Jam Nut(50) and remove it. Hold the Piston from turning while unscrewing the Jam Nut by holding the piston hex with a 1-1/8" box wrench (Part #: 09-445-29768).
6. Push out the 1/4" diameter blade retaining Dowel Pin(38) and remove the broken Driving Blade stub.
7. Install a new Driving Blade in the slot and replace the Dowel Pin(38). Screw on the retaining Jam Nut(50) using the same tools. If the Jam Nut becomes worn and loose after frequent removals, it should be replaced.
8. Check the fit, there should be some sideways movement between the Driving Blade and the Jam Nut assembly. This is desirable and helps the blade to align itself with the mating parts.
9. Reassemble the components. Be sure to align the Driving Blade with the slot in the Adapter Foot Assembly(7,6).

**SEAL REPLACEMENT:** There are 7 seals that may require replacement. We recommend that you have your POWERStaple Dealer replace the Seals.

**SEAL KIT:** You may choose to buy a Seal Replacement Kit and replace the seals yourself. It is good practice to replace all seals at one time regardless if only one seal needs replacement.

#### **SEAL DESCRIPTION & NUMBER:**

1. Rubber Seat (#19)
2. Plunger Seal Set (#21)
3. Piston U-Cup Lip Seal (#22)
4. Return Cylinder U-Cup Lip Seal (#23)
5. Piston Rod U-Cup Lip Seal (#24)
6. Plunger Wiper Seal (#25)
7. Return Cylinder O-Ring Gasket (#26)

To change Seals follow these procedures. Be sure the air line is disconnected from the Stapler first before making any repairs. Consult the illustration for the name and location of the following component parts.

#### **SEAL REPLACEMENT REQUIRES REMOVAL OF THE DRIVING BLADE ASSEMBLY:**

1. Disconnect the air supply.
2. Remove Rubber Plunger Cap (#18).
3. Unscrew & remove Body Cap (#2).
4. Push Safety Yoke (#8) aside and unscrew the three #10-32 cap screws holding the Plunger (#12) to the Return Cylinder (#11).
5. Pull the Plunger up and out of the Stapler Body (#1) cavity.
6. Remove the Return Cylinder O-Ring Gasket (#26) located on the top of the Return Cylinder under the Plunger.
7. Turn the Stapler over and remove the four cap screws (#50), that fasten the Adapter Foot and Staple Channel Assembly to the Stapler Body and lift the Assembly off the Body.
8. Remove the Rubber Bumper (#20 or #65).
9. Pull the Driving Blade Assembly out of the Stapler Body by pulling on the Driving Blade.
10. Hold the Piston Rod (#9) with an 11/16 socket over its hex end opposite the Piston. **Do not use pliers or a vise anywhere on the metal parts, they can damage the sealing surfaces.**
11. Use box wrenches to remove the 5/8-18 Jam Nut (#51). Remove the Dowel Pin (#38) and Driving Blade (#14).
12. Unscrew the Piston from the Piston Rod using box wrenches and separate the Piston, Piston Rod and Return Cylinder.

## **OPERATING INSTRUCTIONS, *continued***

### **TO REPLACE THE SEALS:**

#### **Rubber Seat (#19):**

1. Remove the Cylinder Sleeve (#13). The Cylinder Sleeve should slide out of the Stapler Body when you pull out the Driving Blade Assembly.
2. Remove the metal Support Ring (#17) and Rubber Seat from inside the Stapler body. Note that the chamfer on the inside of the Rubber Seat faces the BOTTOM of the Stapler, do not reverse the direction of the chamfer when you replace the Rubber Seat.
3. Replace the Rubber Seat, Support Ring and Cylinder Sleeve. Be sure to re install the steel Cylinder Sleeve with the chamfered inside edge facing the BOTTOM of the Stapler

#### **Plunger Seal Set (#21):**

1. Remove the Teflon<sup>®</sup> Seal and its O-Ring expander from the groove using a bent paper clip or pick. Be sure not to scratch the inside walls of the seal groove with the wire hook.
2. Clean out the seal groove. Place a new O-Ring into the seal groove by stretching it over the Plunger body. Make sure the O-Ring is not twisted in the groove. Place a new Teflon<sup>®</sup> Seal Ring into the seal groove over the O-Ring.
3. Carefully push the Teflon<sup>®</sup> Seal Ring over the edge of the Plunger with your thumbs and into the groove. Do this as quickly as possible to reduce stretching of the Teflon<sup>®</sup> Seal Ring. **DO NOT OVER STRETCH THE TEFLON<sup>®</sup> SEAL RING!** Be sure the Teflon<sup>®</sup> Seal Ring is centered all around the seal groove and not twisted.
4. Wipe off the Seal surface with a clean rag and lubricate it generously with Pneumatic Light Air Tool Oil lubricant.

#### **Piston U-Cup Lip Seal (#22):**

1. Remove the old Piston U-Cup Lip Seal from the Piston using a bent paper clip or pick, being careful not to scratch the inside walls of the seal groove or the edge of the Piston with the wire hook.
2. Clean out the seal groove. Place a new U-Cup Lip Seal into the groove. Make sure the lips is not twisted in the groove and the lips face the top of the Stapler See the sketch below.
3. Carefully wipe off the U-Cup Lip Seal surface with a clean rag and lubricate it generously with Pneumatic Light Air Tool Oil lubricant.

#### **Return Cylinder U-Cup Lip Seal (#23):**

1. Use a bent paper clip or pick to remove the old U-Cup Lip Seal from the internal seal groove inside the Return Cylinder. Be careful not to scratch the inside walls of the seal groove with the wire hook.
2. Clean out the seal groove. Place a new U-Cup Lip Seal into the groove, be sure it is not twisted in the groove. Be sure the lips are facing the inside of the Return Cylinder as shown in the schematic (page 10-11).

**WARNING:** The U-Cup Lip Seals #23 and #24 look alike, but they are different, DO NOT mix them up.

3. Carefully wipe off the Lip Seal surface with a clean rag and lubricate it generously with Pneumatic Light Air Tool Oil lubricant.

#### **Piston Rod U-Cup Lip Seal (#24):**

1. Remove the old U-Cup Lip Seal from the seal groove with a bent paper clip or pick using care not to scratch the inside walls of the seal groove with the wire hook.
2. Clean out the seal groove and install a new U-Cup Lip Seal. Be sure the Lips are facing the right direction and are not twisted in the groove. See the sketch below.

**WARNING:** The Lip Seals #23 and #24 look alike, but they are different, DO NOT mix them up.

3. Carefully wipe off the seal surface with a clean rag and lubricate it generously with Pneumatic Light Air Tool Oil lubricant.

#### **Plunger Wiper Metal Cap O-Ring (#25):**

1. Use a bent paper clip to pick out the felt Wiper Seal out of its groove in the Body Cap (2).
2. Clean out the groove and insert the new O-Ring (25) in to the groove in the metal body cap (2).

#### **Return Cylinder O-Ring Gasket (#26):**

1. Place a new O-Ring Gasket in the groove on top of the Return Cylinder when you reassemble the Driving Blade Assembly.
2. Wipe off the O-Ring Gasket seal surface and lubricate it generously with Pneumatic Light Air Tool Oil lubricant.



## **OPERATING INSTRUCTIONS, *continued***

### **REASSEMBLING THE Stapler:**

1. Be sure the Rubber Seat, Support Ring and Cylinder are installed in the Body and are facing the correct way.
2. All seal surfaces must be clean and lubricated generously with Pneumatic Light Air Tool Oil lubricant.  
Replace any part that shows signs of wear.
3. Use care when installing the seals into their respective cavities. Be sure the Seals are contained in their groove and do not come out as the parts slide together. Generous cavity lead in chamfers have been provided to help Seal installation.
4. Carefully insert the Piston Rod into the return Cylinder and screw the Piston onto the rod. Be sure the Piston is facing the correct way, ears up, hex down.
5. Assemble the Driving Blade, Dowel Pin and Jam Nut on to the Piston Rod.
6. Insert the Driving Blade Assembly up into the bottom of the Stapler Body Cylinder.
7. Be sure there is a new O-Ring Gasket in the top groove of the Return Cylinder.
8. Insert the Plunger into the top cavity of the Body. Line up the holes and install the three Plunger retaining screws. It is important that the three #10-32 screws are tight or air leakage will occur. Our recommendation is to use 1-2 drops of blue Loctite® or similar on the 3 screws.
9. Position the Safety Yoke in the Plunger groove.
10. Install the Body Cap and Plunger Rubber Cap.
11. Turn the Stapler upside down. Install the Rubber Bumper, Staple Channel Assembly and Adapter Foot. Be sure to align up the Driving Blade with the slot in the Foot before the Stapler is closed up.
12. NEVER FIRE THE Stapler WITHOUT THE

RUBBER BUMPER INSTALLED, IT WILL DAMAGE THE Stapler.

### **TO CLEAR A Staple JAM:**

1. It helps to tap the Driving Blade back to the retracted position before trying to remove a jammed staple. A spare Driving Blade works best for this.
2. Try to pull the jammed staple out of the gate with a pair of long nose pliers. If this does not work remove the four (4) cap screws holding the Foot, Gate and Staple Channel Assembly together.
3. Separate the Foot and gate with a screw driver just enough to clear out the jammed staple.
4. Put thread locking compound on all screws and reassemble the components.

For Step-by-Step Videos and Instructions,  
Visit our Web Site at: [www.Powernail.com](http://www.Powernail.com)

## MODELS 445FS PARTS LIST

**For this parts list and other Powernailer schematics, please visit the  
Powernail Parts Store at <http://www.powernail.com>**

Item #	PART NO.	DESCRIPTION	Qty Req'd	Tuneup Kit	Seal Kit	Sold Separate or Assembly #
1	09-445-29320	Body	1			F
2	09-445-29321	Cap	1			S
3	09-445-29703	Handle, Long	1			A-6
4	09-445-29703.1	Handle, Short	1			A-7
5	09-445-29704	Handle, Half	1			A-6, A-7, A-19
6	09-445-29705	Adapter Foot	1			S
7	09-445-29706	Foot	1			S, A-9
8	09-445-29707	Safety Yoke	1			S
9	09-445-29710	Piston Rod	1			S, A-11
10	09-445-29711	Piston	1			S, A-11
11	09-445-29830	Return Cylinder	1			S, A-11
12	09-445-29831	Plunger	1			S, A-11
13	09-445-29715	Cylinder Sleeve	1			S
14	09-445-29303	Driving Blade	1	TU		S, A-11
15	09-445-29719	Body Plate (.062 Thick)	1			S
16	09-445-29720	Trigger	1			S, A-6, A-7, A-19
17	09-445-29721	Support Ring	1			S
18	09-445-29722	Rubber Cap	1	TU		S
19	09-445-29723	Rubber Seat	1	TU	SEAL	S, A-11
20	09-445-29724	Rubber Bumper	1	TU		S, A-11
21	09-445-29725	Plunger Seal Set	1	TU	SEAL	S, A-11
22	09-200-3026	Piston U-cup Seal	1	TU	SEAL	S, A-11
23	09-200-3027	Return Cylinder U-cup Seal	1	TU	SEAL	S, A-11
24	09-200-3028	Piston Rod U-cup Seal	1	TU	SEAL	S, A-11
25	09-445-29729	Plunger Wiper Metal Cap O-Ring	1	TU	SEAL	S
26	09-445-29731	Return Cylinder O-ring Gasket	1	TU	SEAL	S, A-11
27	09-445-29732	Trigger Cable, Long	1			S, A-6
28	09-445-29732.1	Trigger Cable, Short	1			S, A-7
29	09-445-29733	Safety Yoke Springs	2			S
30	09-445-29326	Staple Pusher Spring	1			S, A-9, A-10
31	09-445-29327	#8-32 X 5/16 B.h.c.s. (Channel)	2			S, A-9
32	09-445-29328	#8-32 X 1/4 F.h.c.s. (Channel)	1			S, A-9, A-10
33	09-445-29329	Steel Staple Pusher	1			S, A-9, A-10
34	09-445-29736	1/2" Adapter Pad (Accessory)	1			S, A-1
35	09-445-29737	5/8" Adapter Pad (Standard)	1			S, A-2
36	09-445-29738	3/4" Adapter Pad (Standard)	1			S, A-3
37	09-445-29739	1/4" X 3/4" Dowel Pin (Trigger)	1			S, A-6, A-7, A-19
38	09-445-29740	1/4" X 1/2" Dowel Pin (Drv. Blade)	1	TU		S, A-11
39	09-445-29815	Handle, Extra Long	1			A-19
40	09-445-29816	Trigger Cable, Extra Long	1			S, A-19

KEY: S=Sold Separately, A= Sold as part of assembly, Kits=Tune-up Kit, Overhaul Kit, or Seal Kit.



## MODELS 445FS PARTS LIST, CONTINUED

Item #	Part No.	Description	Qty. Req'd	Tune-up Kit	Seal Kit	Sold Separate or Assembly #
41	09-445-29331	#8-32 X 1-1/2" S.H.C.S. (Standoff)	1			S, A-9
42	09-445-29325	Two Part Channel W/two B.H.C.S.	1			S, A-9
43	09-445-29305	Gate Plate	1	TU		S, A-9
44	09-445-29330	Gate	1	TU		S, A-9
45	09-445-29756	1/4 X 1 Standoff Space (Channel)	1			S, A-9
46	09-445-29742	1/4-20 X 7/8 S.H.C.S. (XL Handle Only)	1			S
47	09-445-29743	1/4-20 X 1 S.H.C.S.. (Cap)	4			S
48	09-445-29744	1/4-20 X 3/4 S.H.C.S. w/patch (Handle Base)	4			S
49	09-445-29747	1/4-20 X 1-1/4 S.H.C.S. (Foot)	4			S
50	09-445-29748	5/8-18 Jam Nut (Driving Blade)	1	TU		S, A-11
51	09-445-29317	#10-32 X 1" S.H.C.S. W/patch (Foot)	4			S, A-9
52	09-445-29832	#10-32 X 3/4 S.H.C.S. (Plunger)	1			S, A-11
53	09-445-29757	1/4-20 X 1/2 F.H.C.S. (Pad)	1			S
54	09-445-29758	1/4-20 Split Ring Lock Washer	4			S
55	09-445-29759	3/8 Npt 45 Degree Street Elbow	1			S
56	09-445-29760	#8-32 X 3/8 B.H.C.S. (Cable)	1			S
57	09-445-29836	#10-32 X 3/8" S.H.C.S. (Gate)	2	TU		S, A-9
58	09-445-29313	#6-32 X 1/2" F.H.C.S. w/patch (Gate)	2	TU		S, A-9
59	09-445-29819	.030 Plastic Shim	2			S
60	09-445-29738.1	22mm Adapter Pad	1			S
61	09-445-297441	1/4-20 X 3/4" S.H.C.S. (Handle Half)	2			S, A-6, A-7, A-19

KEY: S=Sold Separately, A= Sold as part of assembly, TU=Tune-up Kit, F=Factory replacement only, or Seal Kit.

### Assemblies, Kits & Accessories

ITEM #	PART NO.	DESCRIPTION	QTY. REQ'D
A-1	09-445-29736	1/2" Adapter Pad	1
A-2	09-445-29737	5/8" Adapter Pad	1
A-3	09-445-29738	3/4" Adapter Pad	1
A-4	09-445-29757A	6 Oz. Air Tool Oil	1
A-5	09-200-3058A	Seal Kit (1 Each Of All Seals)	1
A-6	09-445-29759A	Long Handle Assembly	1
A-7	09-445-29760A	Short Handle Assembly	1
A-9	09-445-29365A	Staple Channel Assembly	1
A-10	09-445-29366A	Staple Pusher Assembly	1
A-11	09-445-29364A	Driving Blade Assembly w/seat	1
A-13	09-445-29766	3/8" M&f Coupling Set	1
A-15	09-445-29768	Box Wrench	2
A-19	09-445-29824A	Extra Long Handle Assembly	2
A-24	09-AW-445	Allen Wrench Set	1
A-25	09-445FS-TU-KIT	Tune Up Kit For 445fs	1

# Pneumatic Seal Part Numbers and Locations

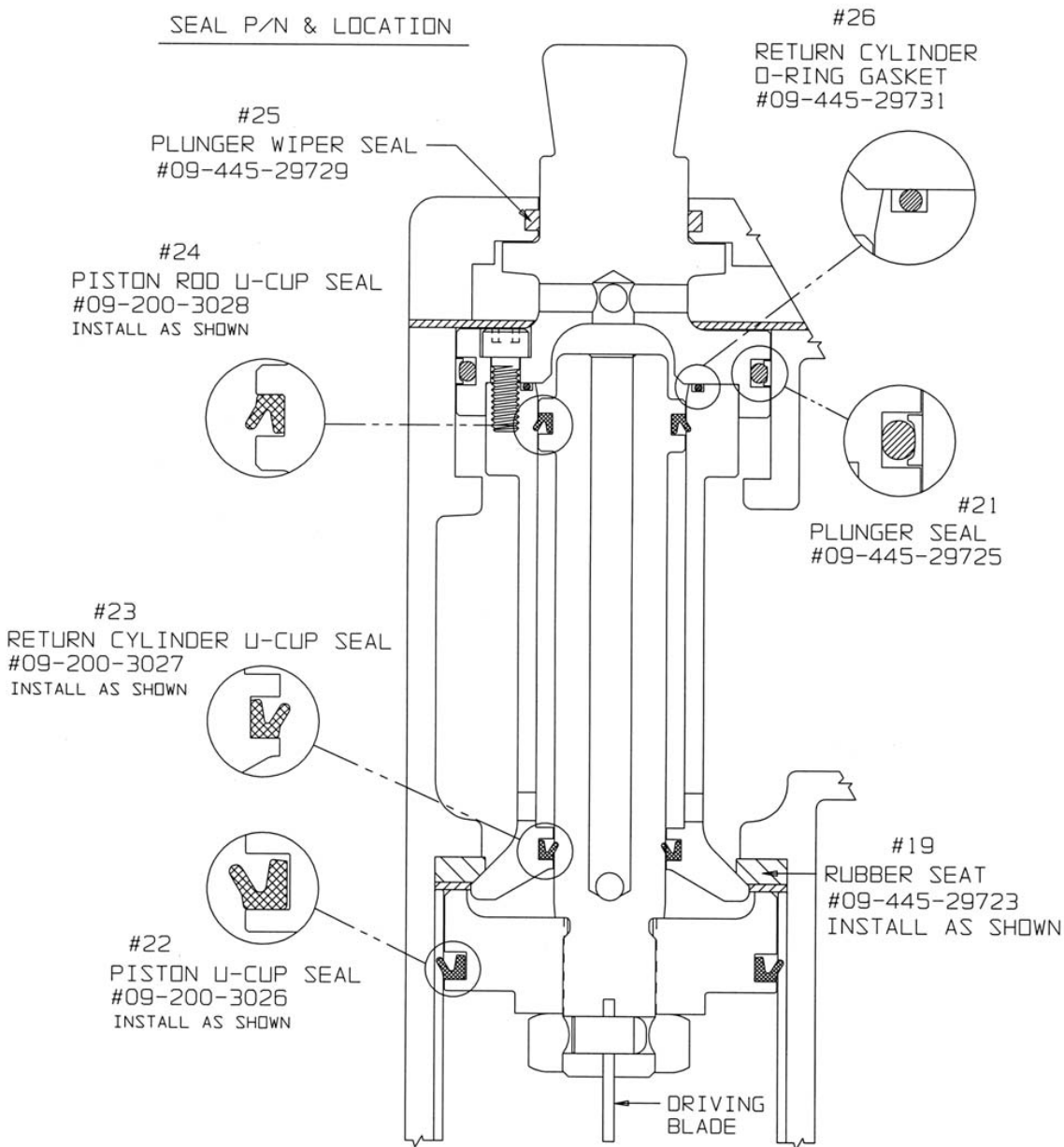

# 445FS PowerStapler SCHEMATIC VIEW

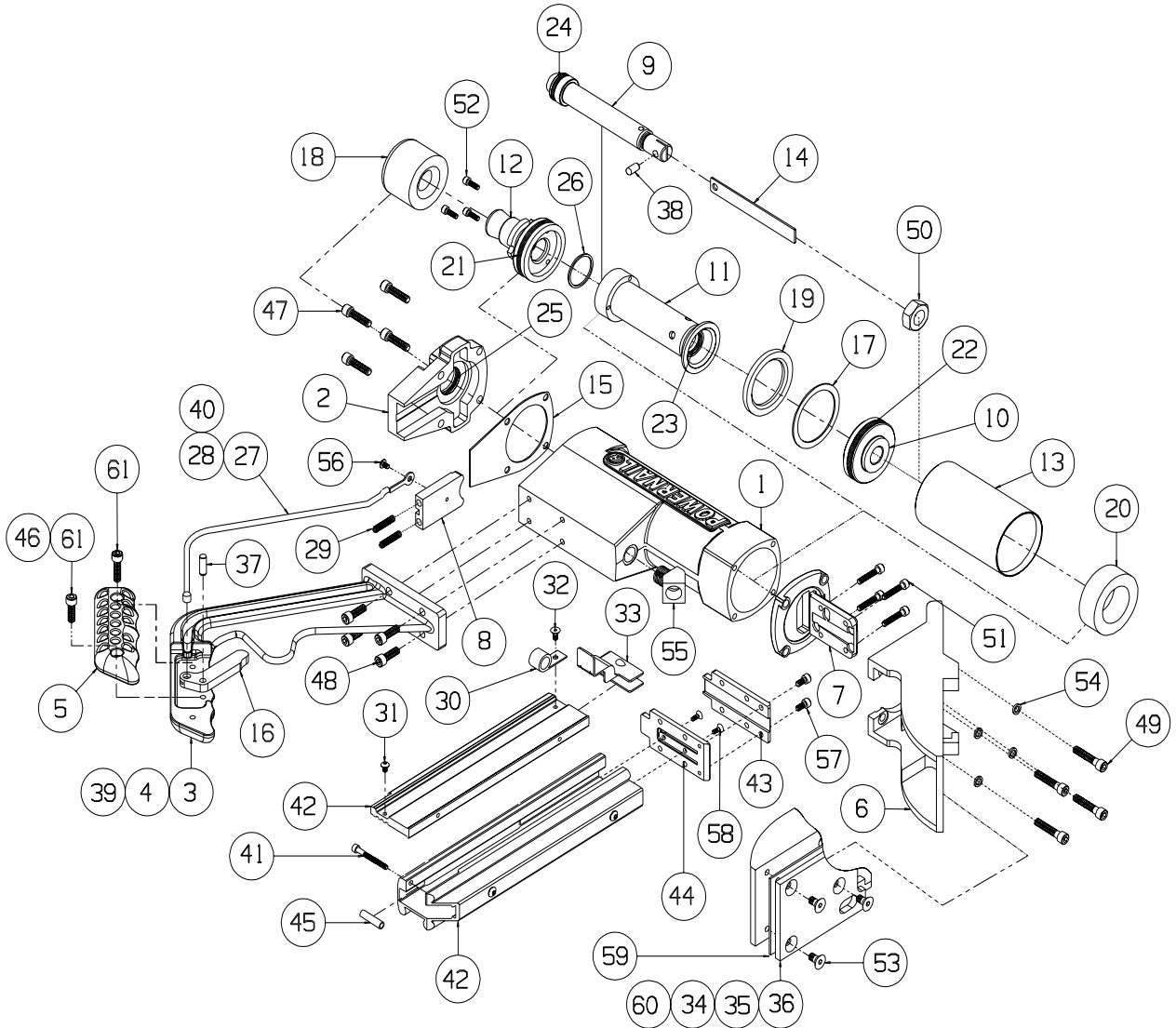

## Kits Available - For use on the Model 445FS Stapler

Seal Kit (1 Each Of All Seals)	Tune-up Kit	Overhaul Kit
Part #: 09-2003058A Schematic #'s: 19,21,22,23,24,25,26	Part #: 09-445FSTUKIT Schematic #'s: 14,18,19, 21,22,23,24,25,26,38,43,44, 50,57(2),58(2)	Part #: 09-445FSOVHKIT Schematic #'s: 9,10,11,12,14,17,18, 19,21,22,23,24,25,26,30,32,33,38, 43,44,50,51(4),52,57(2),58(2)

**For Step-by-Step Videos and Instructions,  
Visit our Web Site at: [www.Powernail.com](http://www.Powernail.com)**

# STAPLER SAFETY DECALS

## **Warning!**



• Read and understand the tool labels and manuals before operating. • Operators and others in work area **MUST** wear **EYE** and **EAR** protection. • Use safety glasses with side shields. • **NEVER** point tool at yourself or others in the work area. • Only connect air to an unloaded tool and always keep tool pointed in a safe direction. • Disconnect air when clearing jams, servicing or when tool is not in use. • Use only clean, dry, regulated air not exceed 110 psi. • Never use oxygen or other bottled gasses-explosion may occur. • Do not tie down, alter or remove the Safety Trigger.

## CAUTION

1. Do not tie down the Safety Trigger
2. To prevent accidental discharge never attach air hose to loaded Nailer.

### Caution:

To  
Prevent  
Accidental  
Discharge  
Never  
Attach  
Air Hose  
To  
Loaded  
Nailer

**CAUTION:**  
Lubricate  
Nailer with  
2-4 drops of  
Industrial Light  
Oil for every  
8 hours of use.

↑  
**R**  
**E**  
**L**  
**O**  
**A**  
**D**

Refill the nail channel with a clip of Powercleats when empty.

Pull the Nail-Pusher assembly to the back of the channel when cleats are reloaded.



Nailer is activated by striking the plunger. Do not work on scaffolding, ladders, elevated or uneven surfaces where the nailer could fall and self-activate. Do not leave air attached to the Nailer when moving from one install location to another.

## PowerStapler 445FS Trouble Shooting Chart

PROBLEM		POSSIBLE CAUSE	SOLUTION
1	Driving blade does not retract	1. Zero or Low air pressure	Check air supply for 80 psi minimum to 110 psi maximum
		2. Lack of lubrication	Manually lubricate through male air inlet fitting
		3. Excessive dirt inside Stapler	Disassemble and clean
		4. Bent or burred driving blade	Replace driving blade (14)
		5. Seals worn out	Replace all seals (Seal Kit A-5)
		6. U-Cup Lip Seals installed upside down	Replace all seals (Seal Kit A-5)
		7. Seals need to be seated — dry fire Stapler	
2	Driving blade retracts slowly	1. Low air pressure	Turn up air pressure to 80-110 psi max
		2. Lack of lubrication	Manually lubricate through male air inlet fitting
		3. Air supply restricted by small orifice	Use 1/4" minimum diameter air fittings
		4. U-Cup Lip Seals installed upside down	Replace all seals (Seal Kit A-5)
		5. Excessive dirt inside nailer	Disassemble, clean and lubricate
3	Staple is not countersunk	1. Low air pressure	Turn up air pressure to 80-110 psi max
		2. Broken Driving Blade	Replace Driving Blade (14)
		3. Stapler hit hard surface	Move from obstruction
		4. Driving blade jam nut came loose	Retighten or replace jam nut (50)
		5. Worn out gate	Replace gate (44)
4	Stapler leaks air	1. Air supply fittings loose	Tighten all air line fitting connections
		2. Dry wall dust in Stapler	Rebuild Stapler
		3. Excess air pressure blew out seals	Check air supply for 110 psi maximum—replace all seals
		4. Plunger screws loose	Tighten 3 plunger screws (52)
		5. Cracked or damaged body	Replace body (1)
		6. Seals worn out	Replace all seals (Seal Kit A-5)
		7. Seals need to be seated	Dry fire Stapler
5	Bottom of stapler cracked off	1. Operated without rubber bumper installed	Replace damaged parts
		2. Excessive air pressure used	Replace damaged parts
6	Staples jam in nailer	1. Not using Powerstapler™ Staples	Use Powerstapler™ Staples only (2",1-3/4",1-1/2" Lengths)
		2. Continued use after a short hit	Clear staple immediately after short hit
		3. Staple pusher damaged or spring broken	Replace staple pusher assembly (A-10)
		4. Staple channel loose	Tighten staple channel retaining screws (49, 51)
		5. Bent staple stuck in staple guide	Disassemble and clear out bent staple
		6. Hit another set staple or hard object	Move from obstruction
		7. Stapler gate worn out	Replace staple gate (44)
7	Plunger locked up—won't move or fire	1. Safety trigger not being depressed	Replace damaged plunger, safety yoke and plunger seal (12, 8, 21)
		2. Lack of lubrication	Manually lubricate through male air inlet fitting

# POWERSTAPLE DEPTH CHART

This chart will assist you in determining the proper length of PowerStaple® to use for various thicknesses of flooring. Approximate vertical penetration of the PowerStaple under the hardwood floor is shown for each application. This is only a guide. Results should be tested in the field before proceeding.

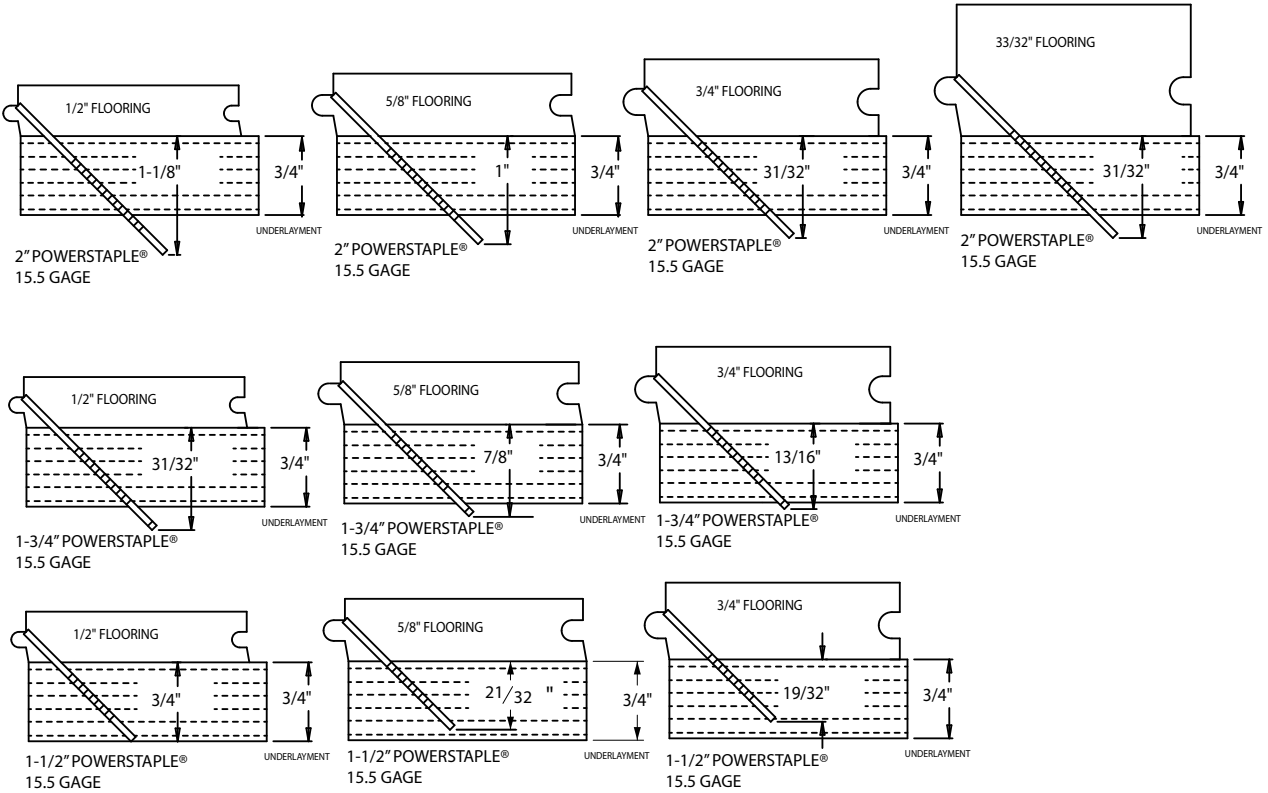

# Visit [www.Powernail.com](http://www.Powernail.com)

- Dealer Locator
- Rental Locator
- Parts Store
- Product Information
- Repair Tech Videos
- Cool Tools Cleat Calculator
- Cleat Depth Chart
- Training Schools

## ***Featured Accessory Products***

### **Powerjack® Model 500**

Truly a Tinker's TOOL, the POWERJACK Model 500 is designed to push or pull flooring strips into place and hold them tightly. The PowerJack Model 500 self adjusts from 5/16" to 3/4" thickness flooring. It can be used to either push or pull wood flooring strips into place and ratchets tightly for hands free operation. The base of the PowerJack 500 has mounting holes for mid-floor use. Simply screw nail the PowerJack 500 to your sub floor -in front of your flooring strips -and ratchet the flooring strips tight. Also great for under cabinet and kick plate installation.

**Part number: 06-99650**

### **The PowerPalm™**

"The PowerPalm is the industries best solution to blind nailing close to the wall. Saves both, time and money!"

Pressure activated...simply press down, and let the tool do the work. The Power Palm will allow blind nailing closer to the wall and reduce the amount of face nailing. "Blind nail, top nail...tight spots and corners, the PowerPalm gets them all!" Featuring 360 degree swivel tip for fitting awkward or tight spaces. Magnetic cleat holder keeps nail in position. Uses both 16 gage and 18 gage Powercleats—Use the same fastener throughout your install! **Part number: 02-PALM001**

### **Powernailer® TOOL BAG™**

The TOOL BAG holds all Powernailer® configurations including the FLEX and POWER ROLLER models. The Powernail TOOL BAG is built tough with a double wall of padded industrial nylon to protect your tools. Corners are reinforced with leather for durability. Zippered storage pouch on the inside (12" x 6"). The Tool Bag has two durable handles which can be used for carrying over your shoulder. Dimensions: 20" base, 7" deep and 20" Tall.

**Part number: 06-99201**



**Powerjack  
Model 500**



***Closest you  
can get to  
the wall!***

**Pneumatic PowerPalm™**



**TOOL BAG**



**POWERNAIL COMPANY, INC.**  
**1300 Rose Road, Lake Zurich, IL 60047 US**  
**Phone: 1-800-323-1653 or 847-847-3000**  
**[www.powernail.com](http://www.powernail.com)**