

# POWERSMART<sup>®</sup>

## INSTRUCTION MANUAL

21-inch Single Stage Gas Snow Thrower

Model # DB7005

	<b>PROBLEMS? QUESTIONS?</b> <b>DO NOT RETURN TO STORE</b> <b>CALL OUR CUSTOMER HELP LINE</b> USA: (800)791-9458 Mon-Fri 9-5 EST Canada: (888)980-4937 Mon-Fri 9-5 EST
---	---



**Have product questions or need technical support? Please feel free to contact us!**

**Website:** [www.Amerisuninc.com](http://www.Amerisuninc.com)

[www.powersmartusa.com](http://www.powersmartusa.com)

**Toll free:** USA (800)791-9458 Mon-Fri 9-5 EST

Canada (888)980-4937 Mon-Fri 9-5 EST

**Email:** [support@amerisuninc.com](mailto:support@amerisuninc.com)



# **CONTENTS**

Technical data.....	3
Introduction.....	4
Safety information.....	4
Knowing your snow thrower.....	10
Assembly and adjustments.....	12
Snow thrower preparation.....	14
Operating your snow thrower.....	15
Maintenance.....	17
Storage & Cleaning.....	18
Troubleshooting.....	19
Exploded view and parts list.....	20
Two (2) years limited warranty.....	24

# **TECHNICAL DATA**

## **21-inch Single Stage Gas Snow Thrower**

Model #:	DB7005
Engine:	196cc Snow Engine
Engine oil Capacity:	20 fl.oz
Fuel Tank Capacity:	0.42 Gallon
Start System:	Recoil Starter
Clearing Width:	21 in
Clearing Height:	12.5 in
Chute Rotation Angle:	180°
Tire Size:	6 in
Overall Dimensions (L x W x H):	28 x 22.8 x 20.9 in
Weight:	79 lbs.

Thank you for purchasing Power Smart products. Please register online at **www. Amerisuninc.com**. The information will allow us to track your warranty and update on your unit.

Important: Our company does not provide email or personal information to any third party for any reason. For any questions check our website or call customer service at (800)791 9458 (USA) or (888)980-4937 (Canada).

# INTRODUCTION

Thank You for Purchasing a PowerSmart® Product. This manual provides information regarding the safe operation and maintenance of this product. Every effort has been made to ensure the accuracy of the information in this manual. PowerSmart® reserves the right to change this product and specifications at any time without prior notice.

Please keep this manual available to all users during the entire life of the snow blower.



This manual contains special messages to bring attention to potential safety concerns, snow blower damage as well as helpful operating and servicing information. Please read all the information carefully to avoid injury and machine damage.

## **QUESTIONS? PROBLEMS?**

In order to answer questions and solve problems in the most efficient and speedy manner, contact Customer Service at USA (800) 791-9458 or Canada (888)980-4937, Mon-Fri 9am-5pm EST or email: support@amerisuninc.com.

## **NOTICE REGARDING EMISSIONS**

Engines that are certified to comply with U.S. EPA emission regulations for SORE (Small Off Road Equipment), are certified to operate on regular unleaded gasoline, and may include the following emission control systems: (EM) Engine Modifications and (TWC) Three-Way Catalyst (if so equipped).

# SAFETY INFORMATION



This symbol points out important safety instructions which, if not followed, could endanger the personal safety and or property of yourself and others. Read and follow all instructions in this manual before attempting to operate this machine. Failure to comply with these instructions may result in personal injury.



**WARNING!** This machine was built to be operated according to the safe operation practices in this manual. As with any type of power equipment, carelessness or error on the part of the operator can result in serious injury. This machine is capable of amputating fingers, hands, toes and feet and throwing foreign objects. Failure to observe the following safety instructions could result in serious injury or death.

It is your responsibility to restrict the use of this power machine to persons who read, understand and follow the warnings and instructions in this manual and on the machine.



**ROTATING PARTS!** Only use clean-out tool to clear blockages. NEVER use your hands.



NEVER direct discharge towards persons or property that may be injured or damaged by thrown objects.



Keep people away from unit while operating. Keep children out of work area and under watchful care of a responsible adult.

## **TRAINING**

Read, understand, and follow all instructions on the machine and in the manual(s) before attempting to assemble and operate. Keep this manual in a safe place for future and regular reference.

- Be familiar with all controls and their proper operation. Know how to stop the machine and disengage them quickly.
- Never allow children under 14 years of age to operate this machine. Children 14 and over should read and understand the instructions and safe operation practices in this manual and on the machine and be trained and supervised by an adult.
- Never allow adults to operate this machine without proper instruction.
- Thrown objects can cause serious personal injury. Plan your snow-throwing pattern to avoid discharge of material toward roads, bystanders and the like.
- Keep bystanders, pets and children at least 75 feet from the machine while it is in operation. Stop machine if anyone enters the area.
- Exercise caution to avoid slipping or falling, especially when operating in reverse.

## **PREPARATION**

Thoroughly inspect the area where the equipment is to be used. Remove all doormats, newspapers, sleds, boards, wires, branches and other foreign object, which could be tripped over or thrown by the auger /impeller.

- Always wear safety glasses or eye shields during operation and while performing an adjustment or repair to protect your eyes, thrown objects which ricochet can cause serious injury to the eyes.
- Do not operate without wearing adequate winter outer garments. Do not wear jewelry, long scarves or other loose clothing, which could become entangled in moving parts, wear footwear which will improve footing on slippery surfaces.
- Use a grounded three-wire extension cord and receptacle for all machines with electric start engines.
- Adjust housing height to clear gravel or crushed rock surfaces.
- Disengage all control levers before starting the engine.
- Never attempt to make any adjustments while engine is running, except where specifically recommended in the operator's manual.
- Let engine and machine adjust to outdoor temperature before starting to clear snow.

## **PERSONAL SAFETY**

- Engine exhaust, and certain vehicle components contain or emit chemicals known to cause cancer, birth defects or other reproductive harm.

- Read, understand and follow all instructions on your Snow Thrower and in this Operator's Manual before attempting to assemble and operate your machine.
- Keep this manual in a safe place for future and regular reference. If replacement parts are needed, refer to the manual.
- Stay alert, watch what you are doing and use common sense when operating your Snow Thrower.
- Do not use your Snow Thrower while you are tired or under the influence of drugs, alcohol, medication. A moment of inattention while operating the Snow Thrower may result in severe bodily injury.
- NEVER LEAVE YOUR RUNNING SNOW THROWER UNATTENDED. Stop the engine.
- Do not leave your Snow Thrower until it has come to a complete stop.
- When stepping backwards, be cautious about any obstacles beneath your feet or behind you avoid falling.

## **SERVICE**

- Stop the engine before making any adjustments. Check for misalignment, breakage of or binding of moving parts, and any other conditions that may affect operation.
- If damaged, have the Snow Thrower serviced by a qualified repair person using only identical replacement parts. This will ensure that the safety of the Snow Thrower is maintained.

## **SAFE HANDLING OF GASOLINE**

To avoid personal injury or property damage use extreme care in handling gasoline. Gasoline is extremely flammable and the vapors are explosive. Serious personal injury can occur when gasoline is spilled on yourself or your clothes which can ignite, wash your skin and change clothes immediately.

- Use only an approved gasoline container.
- Extinguish all cigarettes, cigars, pipes and other sources of ignition.
- Never fuel machine indoors.
- Never remove gas cap or add fuel while the engine is hot or running.
- Allow engine to cool at least two minutes before refueling.
- Never over fill fuel tank.
- Replace gasoline cap and tighten securely.
- If gasoline is spilled, wipe it off the engine and equipment. Move machine to another area. Wait 5 minutes before starting the engine.

- Never store the machine or fuel container inside where there is an open flame, spark or pilot light (e.g. furnace, water heaters, space heater, clothes dryer etc.).
- Allow machine to cool at least 5 minutes before storing.
- Never fill containers inside a vehicle or on a truck or trailer bed with a plastic liner. Always place containers on the ground away from your vehicle before filling.
- If possible, remove gas-powered equipment from the truck or trailer and refuel it on the ground.
- If this is not possible, then refuel such equipment on a trailer with a portable container, rather than from a gasoline dispenser nozzle.
- Keep the nozzle in contact with the rim of the fuel tank or container opening at all times until fueling is complete. Do not use a nozzle lock open device.

## **OPERATION**

- Do not put hands or feet near rotating parts, in the auger impeller housing or chute assembly. Contact with the rotating parts can amputate hands and feet.
- The auger impeller control lever is a safety device. Never bypass its operation. Doing so makes the machine unsafe and may cause personal injury.
- The control levers must operate easily in both directions and automatically return to the disengaged position when released.
- Never operate with a missing or damaged chute assembly. Keep all safety devices in place and working.
- Never run an engine indoors or in a poorly ventilated area. Engine exhaust contains carbon monoxide, an odorless and deadly gas.
- Do not operate machine while under the influence of alcohol or drugs.
- Muffler and engine become hot and can cause a burn. Do not touch. Keep children away.
- Exercise extreme caution when operating on or crossing gravel surfaces. Stay alert for hidden hazards or traffic.
- Exercise caution when changing direction and while operating on slopes.
- Plan your snow-throwing pattern to avoid discharge towards windows, walls, cars etc. Thus, avoiding possible property damage or personal injury caused by a ricochet.
- Never direct discharge at children, bystanders and pets or allow anyone in front of the machine.
- Do not overload machine capacity by attempting to clear snow at too fast of a rate.
- Never operate this machine without good visibility or light. Always be sure of your footing and keep a firm hold on the handles. Walk, never run.

- Disengage power to the auger impeller when transporting or not in use.
- Never operate machine at high transport speeds on slippery surfaces. Look down and behind and use care when backing up.
- If the machine should start to vibrate abnormally, stop the engine, disconnect the spark plug wire and ground it against the engine. Inspect thoroughly for damage. Repair any damage before starting and operating.
- Disengage all control levers and stop engine before you leave the operating (behind the handles).
- Wait until the auger /impeller comes to a complete stop before unclogging the chute assembly, making any adjustments, or inspections.
- Never put your hand in the discharge or collector openings. Always use the clean-out tool provided to unclog the discharge opening. Do not unclog chute assembly while engine is running. Shut off engine and remain behind handles until all moving parts have stopped before unclogging.
- Use only attachments and accessories approved by the manufacturer (e.g. wheel weights, tire chains, cabs etc.).
- When starting engine, pull cord slowly until resistance is felt, then pull rapidly, Rapid retraction of starter cord (kickback) will pull hand and arm toward engine faster than you can let go. Broken bones, fractures, bruises or sprains could result.
- If situations occur which are not covered in this manual, use care and good judgment contact customer support for assistance.

## **MAINTENANCE & STORAGE**

- Never tamper with safety devices. Check their proper operation regularly. Refer to the maintenance and adjustment sections of manual.
- Before cleaning, repairing, or inspecting machine disengage all control levers and stop the engine.
- Wait until the auger impeller comes to a complete stop. Disconnect the spark plug wire to prevent unintended starting.
- Check bolts and screws for proper tightness at frequent intervals to keep the machine in safe working condition. Also, visually inspect machine for any damage.
- Do not change the engine governor setting or overspeed the engine. The governor controls the maximum safe operating speed of the engine.
- Snow thrower shave plates and skid shoes are subject to wear and damage. For your safety protection, frequently check all components and replace with original equipment manufacturers (OEM) parts only. Use of parts which do not meet the original equipment specifications may lead to improper performance and compromise safety.



- Check control levels periodically to verify they engage and disengage properly and adjust, if necessary. Refer to the adjustment section in this operator's manual for instructions.
- Maintain or replace safety and instruction labels, as necessary.
- Observe proper disposal laws and regulations for gas, oil, etc. to protect the environment.
- Prior to storing, run machine a few minutes to clear snow from machine and prevent freeze up of auger impeller.
- Never store the machine or fuel container inside where there is an open flame, spark or pilot light such as water heater, furnace, clothes dryer etc.
- Always refer to the operator's manual for proper instructions on off-season storage.
- Check fuel line, tank, cap and fittings frequently for cracks or leaks. Replace if necessary.
- Do not crank engine with spark plug removed.
- Have the machine inspected annually by an authorized service dealer to ensure that all mechanical and safety systems are working properly and do not worn excessively. Failure to do so can result in accidents, injuries or death

### **DO NOT MODIFY THE ENGINE**

To avoid serious injury or death, do not modify engine in any way. Tampering with the governor setting can lead to a runaway engine and cause it to operate at unsafe speeds. Never tamper with factory setting of engine governor.

# KNOWING YOUR SNOW THROWER

Use the illustrations below to become familiar with the locations and functions of the various components and controls of this snow thrower.



- |   |                       |    |                       |
|---|-----------------------|----|-----------------------|
| 1 | Auger Control Bar     | 6  | Wheel                 |
| 2 | Chute Rotation Handle | 7  | Fuel Tank             |
| 3 | Discharge Chute       | 8  | Fuel Tank Cap         |
| 4 | Shave Plate           | 9  | Recoil Starter handle |
| 5 | Auger                 | 10 | Upper handle          |

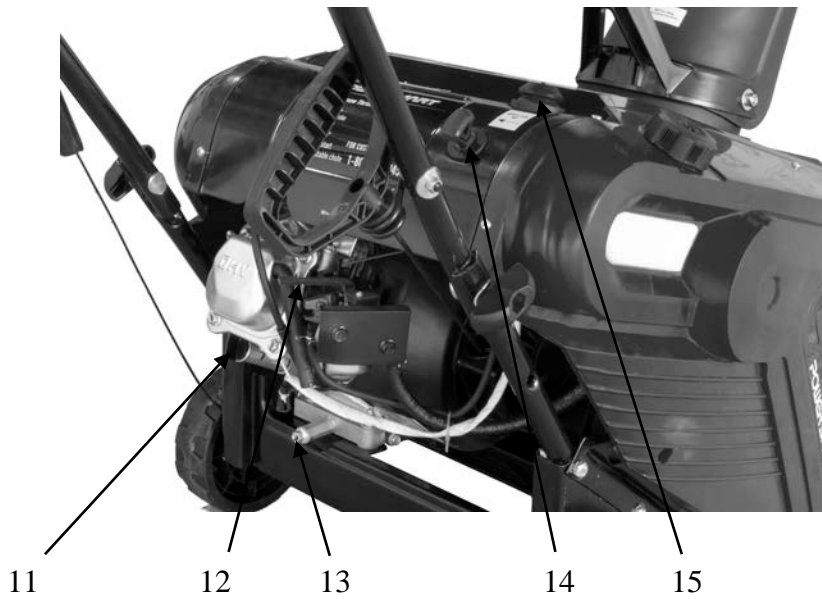

- |    |              |    |             |
|----|--------------|----|-------------|
| 11 | Oil Dipstick | 14 | Switch Key  |
| 12 | Choke lever  | 15 | Primer Bulb |
| 13 | Drain Plug   |    |             |

**Auger Control Bar**

The Auger Control Bar is used to engage and disengage the augers. Pull back the Auger Control Bar to engage the augers; release to disengage the augers.

**Chute Rotation Handle**

To adjust snow discharge direction, rotate the handle clockwise or counter-clockwise.

**Augers**

When engaged, the augers rotate to cut snow and direct it into the auger housing to be discharged out the chute.

**Discharge Chute**

The chute provides a discharge path for snow being thrown. The chute is adjustable.

**Shave Plate**

The Shave Plate maintains contact with pavement as the snow thrower is propelled, allowing snow close to pavement's surface to be discharged.

## **ASSEMBLY AND ADJUSTMENTS**

The following section describes steps necessary to prepare the snow thrower for use. If after reading this section, you are unsure about how to perform any of the steps please call USA (800) 791-9458 or Canada (888)980-4937 Mon-Fri 9-5 EST for customer service. Failure to perform these steps properly can damage the snow thrower or shorten its life.

### **Unpacking**

Unpack the snow thrower and all its parts, and compare against the list below.

1. Snow Thrower
2. Discharge Chute Assembly
3. 2 Wheels

### **ASSEMBLY**

Your Snow Thrower will require some assembly. Please complete the following steps before using your Snow Thrower.



**WARNING:** This snow thrower is heavy. Assembly procedures may require lifting equipment or two people.

#### **Step 1 – Installing the wheels**

1. Remove locknuts from the end of the wheel axle.
2. Position wheel on the axle, then add locknut and tighten firmly with a wrench.
3. Repeat 1 and 2 to install the wheel on another side of the wheel axle.



#### **Step 2 – Upper handle assembly**

1. With the upper handle in the down position, connect the control cable to the auger control bar.



2. Insert the bolts into the aligned holes, with the bolt heads on the inside of the handle.
3. Install the washers and knobs on the bolts on the outside of the handle. Tighten firmly by hand.

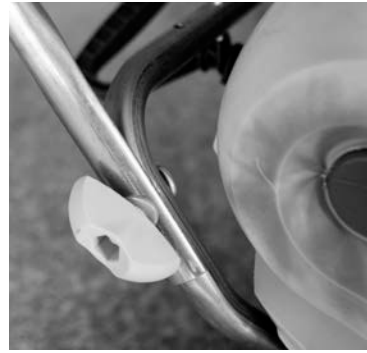

**NOTICE: Do not bend or kink the control cable. The cables should be routed under the Lower handle and not wrapped around the handle or knobs. The cables must move freely and not bind.**

### Step 3 – Chute assembly

1. Remove the bolts, washers and nuts from the chute base.

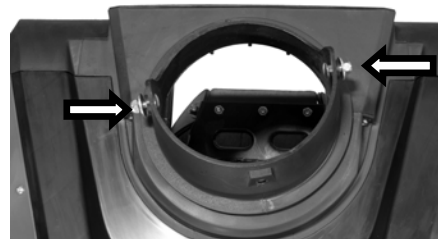

2. Place discharge chute and rotation handle over discharge hole. Make sure the rotation handle was locked in position with discharge chute.



3. Install the bolts from the inside of discharge chute assembly so that the washers and locknuts are on the outside of the chute. Wrench tighten.

Note: Do not overtighten the locknuts.

# **SNOW THROWER PREPARATION**

## **Step 1 - ADD OIL**

The snow thrower is shipped without oil. User must add the proper amount of oil before operating the snow blower for the first time. The oil capacity of the engine crankcase is 20 fl. oz. For general use, we recommend 5W, 4-stroke engine oil.

### **ENGINE OIL RECOMMENDATIONS**

Select good quality detergent oil bearing the American Petroleum Institute (API) service classifications SJ, SL, or SM (synthetic oils may be used). Use the ASE viscosity grade of oil from the following chart that matches the starting temperature anticipated before the next oil changes.

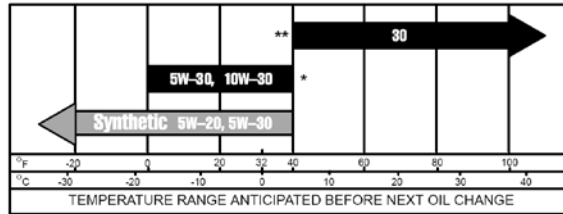

To add oil, follow these steps:

1. Make sure the snow thrower is on a level surface. Tilting the snow thrower to assist in filling will cause oil to flow into engine areas and will cause damage. Keep snow thrower level!
2. Remove the dipstick from the engine.
3. Add oil slowly as to not overflow the unit.
4. To check the oil level, wipe the dipstick with a clean rag. Insert the dipstick into the oil fill opening without screwing it in. Remove the dipstick to check the oil mark.
5. Slowly add more oil and repeat step 4 until the oil mark reaches to the top of the dipstick. Do not overfill the crankcase.
6. Check for oil leaks. Tighten dipstick firmly.

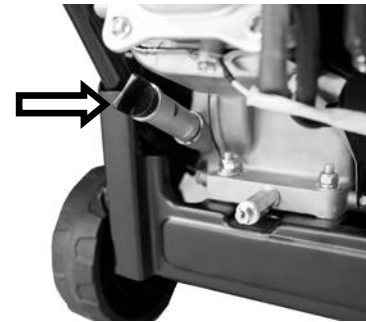

## **Step 2 - ADD GASOLINE**

Use fresh (within 30 days from purchase), lead-free gasoline with a minimum of 87 octane rating. Do not mix oil with gasoline.

To add gasoline, follow these steps:

1. Make sure the snow thrower is on a level surface.
2. Unscrew fuel tank cap and set aside. NOTE: The fuel cap may be tight and hard to unscrew.
3. Slowly add unleaded gasoline to the fuel tank. Be careful not to overfill. The capacity of the fuel tank is 0.66 gallons. NOTE: Do not fill the fuel tank to the very top. Gasoline will expand and spill over during use even with the fuel cap in place.
4. Reinstall fuel cap and wipe clean any spilled gasoline with a dry cloth.

### **IMPORTANT:**

- Never use an oil/gasoline mixture.
- Never use old gasoline.
- Avoid getting dirt or water into the fuel tank.
- Gasoline can age in the tank and make starting difficult. Never store snow thrower for extended periods of time with fuel in the tank or the carburetor.
- **NOTE:** After completing the above preparation, the engine is ready to be started.

## **OPERATING YOUR SNOW THROWER**

The following section describes steps to use your Snow Thrower for use. If after reading this section, you are unsure about how to perform any of the steps please call 1-800-791-9458 for customer service. Failure to perform these steps properly can damage your Snow Thrower or shorten its life.

Review the SAFETY section in this manual before operating the engine and snow thrower.

**WARNING!** Keep the area of operation free from foreign objects that can be thrown by the auger and/or impeller blades. Perform a thorough inspection of the area since some objects may be hidden from view by surrounding snow. If the Snow Thrower hits an obstruction or picks up a foreign object during use, stop the Snow Thrower, remove the obstruction, and inspect it for damage. Repair or replace any damaged parts before restarting and operating you Snow Thrower.

- Keep children, pets, and bystanders away from the area of operation. Be aware that the normal noise of the Snow Thrower when turned on may make it difficult for you to hear approaching people.
- Start your clearing path by throwing snow in a back and forth motion. To clear in the opposite direction, stop your Snow Thrower and pivot it on its wheels to face the opposite direction. Make sure to overlap clearing paths.
- Determine the direction of the wind. If possible, move in the same direction as the wind so that the snow is not thrown against the wind, back into your face and on the just cleared path.

**WARNING! DO NOT USE YOUR HANDS TO UNCLOG CHUTE.** Stop the motor before removing debris. Use the supplied clean out tool to unclog the chute. Do not walk in front of your running Snow Thrower. Do not direct discharged snow towards bystanders.

- Do not apply additional man-made load to the engine since this may damage the engine.
- Some parts of your Snow Thrower may freeze under extreme temperature conditions. Do not attempt to operate your Snow Thrower with frozen parts. If the parts freeze while your Snow Thrower is in use, stop your Snow Thrower and inspect it for frozen parts. Thaw all parts before restarting and operating your Snow Thrower. Never force parts or controls that have frozen. Never use an open flame of any sort to thaw frozen parts.

### **Pre-Operation Inspection - IMPORTANT!!!**

Before using your Snow Thrower for the first time, check the following:

- Have you read and followed all setup and operation procedures for the engine as outlined in the ENGINE manual?
- Has the engine been filled with oil and gasoline to the proper level?
- Are all snow thrower components properly attached and assembled?
- Are there any broken or damaged parts?
- Are all fasteners tight?
- Are the tires inflated to the proper pressure?

**NOTICE:** If you are unsure about the assembly or condition of any of your Snow Thrower parts, please call our customer service department at USA (800)791 9458 or Canada (888) 980-4937.

## STARTING

1. Move the choke lever to START position (Right side).
2. Press the primer bulb 3 times.
3. Insert switch key into slot (Do not turn switch key).
4. Pull on the recoil starter handle slowly until a slight resistance is felt, then pull quickly to start the engine. Return cord gently into the recoil starter. Never allow the cord to snap back.
5. If engine fails to start, repeat step 4. NOTE: After repeated failed attempts to start the engine, please consult the troubleshooting guide before attempting again. If problems persist, please call USA (800) 791-9458 M-F 9-5 EST or Canada (888) 980-4937 M-F 9-5 EST.
6. Once the engine has started, slowly return the choke lever all the way to the "OPEN" position (Left side).
7. Allow the engine to run for several minutes before using snow thrower.



Choke lever    Switch key    Primer bulb

## CLEARING SNOW

Once your Snow Thrower has been running outside for several minutes, it is now ready for use. Make sure the path in front of your Snow Thrower is free from people, animals, objects, and all other obstructions except for snow.

Adjust the chute outlet to the desired direction.

Turn the chute rotation handle clockwise or counter-clockwise until the desired position is reached.

**WARNING!** Never direct the chute outlet toward people or animals. While snow may seem harmless, it can contain rocks or other debris that can cause serious injury when projected through the chute.

1. Engage/depress the auger control handle to start the augers and impeller turning.
2. Set the desired direction and speed using the speed control lever.
3. Engage/depress the drive control handle and direct the snow thrower into the snow to be cleared.

**NOTICE:** Do not change speed positions while the drive is engaged. Disengage the drive control handle BEFORE changing speeds or directions. If the snow is deeper than the height of the auger, remove it in several steps taking narrower swaths. Make several passes with the auger overlapping the cleared areas and reduce forward speed.

For the best clearing efficiency, clear snow before it melts, refreezes and hardens. Hard packed and wet snow can be very difficult to clear.

Clearing wet heavy snow can be a challenge, depending on ambient temperature, humidity levels, and overall climate conditions including actual snow conditions, there may be no 100% solution as snow may be too wet or compacted to move or throw. Wet snow will tend to clog and stick more to the augers and chute. Keep the auger engaged as much as possible when clearing wet snow to help prevent clogging.

**WARNING!** If snow is filled with foreign material, damage to the snow thrower may result. Avoid snow with foreign materials.

## STOPPING

1. Pull out the switch key to stop the engine. Keep in a safe place. Must be reinserted to start the engine.
2. Remove snow from all Snow Thrower surfaces including the auger housing and chute areas.



# **MAINTENANCE**

**WARNING!** Never perform maintenance while your Snow Thrower is running. Turn OFF the engine before performing any maintenance tasks on your Snow Thrower.

Proper maintenance of your Snow Thrower will help prolong its life. Please perform the following maintenance procedures as required.

Do not attempt to repair your Snow Thrower unless you have the proper tools and instructions for disassembly and repair.

Check the bolts at frequent intervals for proper tightness to ensure that the equipment is in safe working condition.

After each snow removal session, run the Snow Thrower for a few minutes to prevent the collector /impeller from freezing. Stop the engine, wait for all revolving parts to stop completely, and wipe residual ice and snow off the unit. Rotate the chute rotation handle several times to remove any excess snow.

## **MAINTENANCE PROCEDURES**

### **RECOMMENDED ENGINE MAINTENANCE SCHEDULE**

Recommended Engine Maintenance Schedule		Each 8 hours	Every 25 hours	Every 3 months or 50 hours	As necessary
Engine Oil	Check level	x			
	Replace		x	x	x
Spark Plug	Check			x	
	Replace				x
Fuel Tank	Check level	x			
	Clean			x	x

Clean or replace more often under dusty conditions or operating under heavy load.

### **CHECKING THE OIL**

Check the oil level of the engine according to the Recommended Maintenance Schedule above. The engine should be checked before each use for proper oil level. This is a critical step for proper engine starting. To check the oil level:

1. Make sure the snow blower is on a level surface.
2. Clean around oil fill. Remove dipstick and wipe the dipstick with a clean rag. Insert the dipstick into the oil fill opening without screwing in. Remove the dipstick to check the oil mark. Add oil if the oil mark covers less than one half of the dipstick.
3. Slowly add more oil and repeat step 2 until the oil mark reaches to the top of dipstick. Do not over fill the crankcase.
4. Reinstall oil dipstick.

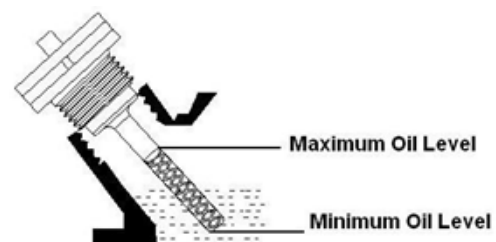

## CHANGING/ADDING OIL

Change the oil according to the Recommended Maintenance Schedule. Change the oil when the engine is warm. This will allow for complete drainage. Change oil more often if operating under heavy load. It is also necessary to drain the oil from the crankcase if it has become contaminated with water or dirt. The oil capacity of the engine is 20 fl.oz. Add oil when the oil level is low. For general use, we recommend 5W, 4-stroke engine oil.

To drain oil, follow these steps:

1. Place a container underneath the engine to catch oil as it drains.
2. Using a wrench, unscrew the oil drain plug. Allow all the oil to drain from the engine.
3. Reinstall the oil drain plug and tighten with a wrench.

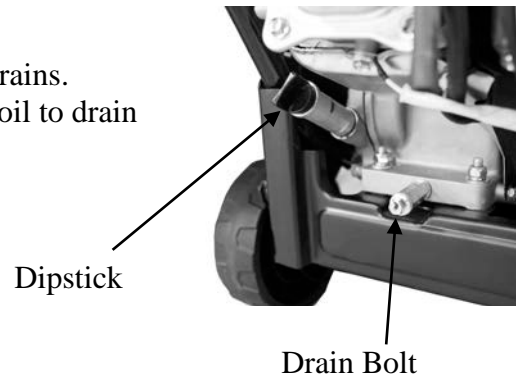

**To refill the crankcase with oil, follow these steps:**

1. Make sure the snow blower is on a level surface. Tilting the snow blower to assist in filling will cause oil to flow into engine areas and will cause damage. Keep snow blower level!
2. Remove the dipstick from the engine.
3. Using a funnel or appropriate dispenser, add the correct amount of oil (20 fl.oz) into the crankcase. The engine is equipped with a low oil sensor and will not start if the amount of oil is insufficient.
4. Reinstall dipstick.

**NOTE:** Never dispose of used motor oil in the trash or down a drain. Please call a local recycling center or auto garage to arrange oil disposal.

## STORAGE & CLEANING

### PROPER STORAGE PROCEDURES

**WARNING!** Never store your Snow Thrower for extended periods of time with fuel in the tank or carburetor. Fuel stabilizer can be added to the fuel in can to extend its shelf life for storage.

Store the unit in a locked, dry place out of the reach of children to prevent unauthorized use or damage. Cover loosely with a tarp for added protection.

### CLEANING

1. To clean your Snow Thrower, use a damp cloth and mild detergent on the surfaces only. Never get soap or water inside the working mechanisms of your Snow Thrower.

**Note:** Do not clean with water. Water will freeze due to low temperature and damage the machine.

2. Clean the Snow Thrower of snow and ice buildup before storing or transporting. Be sure to secure the unit while transporting.
3. Inspect the Snow Thrower carefully for worn, loose, or damaged parts. Check connections and screws and tighten if necessary.

# **TROUBLESHOOTING**

<b>Problem</b>	<b>Causes</b>	<b>Remedy</b>
<p><b>WARNING</b> - Before attempting to make any inspections, repairs or adjustments, stop the engine, wait for all moving parts to stop moving and carefully disconnect the engine spark plug wire. If tipping or turning the snow blower is required for any inspection or repair, first wait until the engine is cool to the touch and then drain the engine of all fuel and oil into suitable containers and store or dispose of in a proper manner.</p>		
<p><b>Engine Systems</b> - Note: For all engine problems, see the Engine Operator's manual for additional troubleshooting information and engine manufacturer contact information.</p>		
Engine Fails to Start (Engine cranks over)	Engine ignition switch in OFF position	Position engine ignition switch to ON
	Spark plug wire disconnected	Connect wire to spark plug
	Faulty spark plug	Clean, adjust gap, or replace spark plug, see Engine Operator's manual
	Engine flooded with fuel	Discontinue choke or primer use, clean or replace spark plug.
	Safety key not inserted in engine ignition	Insert key fully into the switch
	Choke not in START position	Move choke to START position, after engine starts slowly move to RUN position as engine speed and operation stabilizes at the set rpm. If engine still does not start move to half choke and crank engine.
	Engine not primed with fuel	Prime engine, see Engine Operator's manual
	Fuel incorrect, old or stale, will not ignite	Empty and clean fuel tank & carburetor, refill with fresh, clean gasoline. (Note: Fuel may become stale after 30 days in some cases)
	Blocked or clogged fuel system or line	Clean fuel system or line
	Fuel shut-off valve in OFF position	Turn fuel shut-off valve to ON position
Engine runs erratic, stalls or seems low on power	CHOKE in ON or partial ON position	Move CHOKE lever to RUN
	Fuel incorrect, old or stale	Empty and clean fuel tank & carburetor, refill with fresh, clean gasoline. (Note: Fuel may become stale after 30 days in some cases)
	Blocked or clogged fuel system or line	Clean fuel system or line
	Carburetor is in need of cleaning	Clean fuel system and carburetor
	Spark plug wire loose	Connect and tighten spark plug wire
	Faulty spark plug	Clean, adjust gap, or replace spark plug, see Engine Operator's manual
	Engine oil over filled	Drain oil to proper level. Oil should not be above the top 2 threads of LOWER fill plug.
	Engine oil level low or empty	Add oil

# EXPLODED VIEW AND PARTS LIST

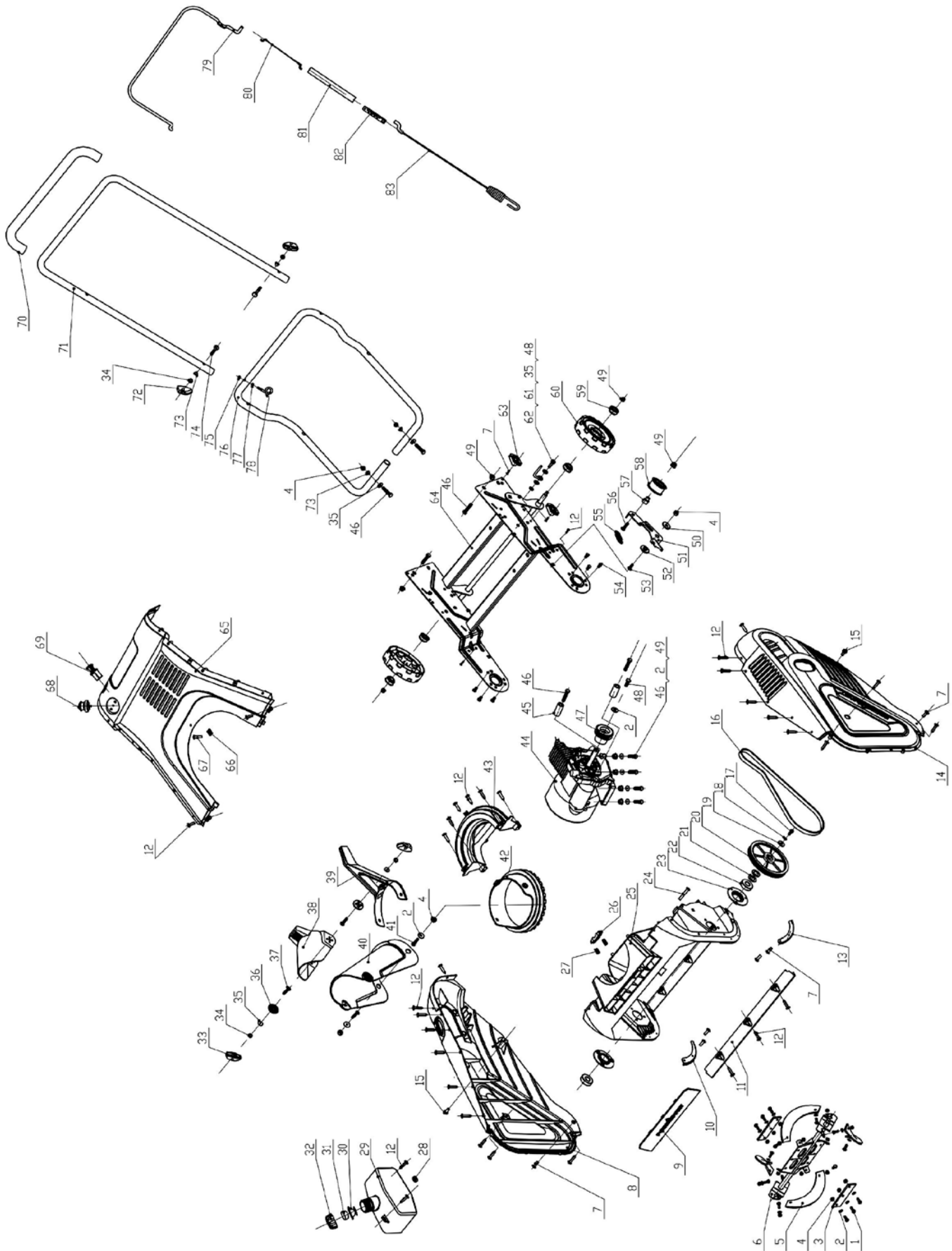

Item	Stock#	Description	Qty
1	303020106	Hex washer screw M10x1	14
2	303042013	flat washer 10	21
3	302110079	Small rubber blade	2
4	303030036	Lock nut	19
5	302110078	Rubber blade	4
6	303180852	Auger axle	1
7	303160655	Screw	8
8	203010748A	Right cover	1
9	203010747	LOGO Plate	1
10	303070739	Right plate	1
11	303070741	Shave plate	1
12	303010316	Screw	34
13	303070738	Left plate	1
14	203010749	Left cover	1
15	303020084	Screw	2
16	302040054	V-belt	1
17	303020282	Hex washer screw	1
18	303041009	Washer M10x16	1
19	303042009	flat washer 10	1
20	203010646	Big pulley	1
21	303042168	Flat washer	2
22	303100034	Ball bearing 6203Z	2
23	303070797	Keeper	2
24	303010216	Screw	1
25	203050170A	Bottom seat	1
26	203010647	Locking block	1
27	303130138	Chute spring	2
28	D00001528	Clip combination	1
29	203050173A	Fuel tank	1
30	302080032	Sealing gasket	1
31	302080033	Fuel cap sponge	1
32	302110017	Fuel cap	1
33	203020865A	Knob	2
34	303030066	Nut	4
35	303042023	Flat washer	6
36	203020380	Washer	2
37	303020146	Screw	2
38	203050174	Chute deflector	1
39	203010648	Chute rotation handle	1
40	203050175	Middle discharge chute	1
41	303020155	Screw	2
42	203050172	Rotator	1

Item	Stock#	Description	Qty
43	203050171	Chute base	1
44	303190253	Engine	1
45	303200098	shock absorb	2
46	303020275	Hex washer screw	10
47	303060099A	Small belt pulley	1
48	303020279	Hex washer screw	2
49	303030077	Lock nut	9
50	303042013	Flat washer	1
51	303070744B	Tensioning plate	1
52	303160651	Spacer bush	1
53	303020161	Screw	1
54	303020276	Hex washer screw	6
55	303160652	Spring	1
56	303020154	Screw	1
57	303210027	Sleeve	1
58	203100003	Tensioning pulley	1
59	203021115	Wheel shaft sleeve	4
60	203050190	Wheel	2
61	303160581A	Belt keeper	1
62	303043016	Washer	1
63	203021096A	Guide bracket	2
64	303180902	Bracket assembly	1
65	203010649A	Middle cover	1
66	303030103	Clamping piece	1
67	303020130	Screw	1
68	D00001529	Primer bulb	1
69	D00001530	Switch	1
70	302020008	Sponge sleeve	1
71	303160506A	upper handle	1
72	203020865A	Knob	2
73	303043010	Saddle washer	4
74	303020057	T bolt	2
75	303030032	Lock nut	1
76	303160505A	Lower handle	1
77	303030065	Nut	1
78	303210026	Recoil holder	1
79	303160507A	Auger control bar	1
80	303200084	Upper auger cable	1
81	302080016A	Cable rubber cover	1
82	303070142	Adjusting bar	1
83	303200097	Lower auger cable	1

Engine exploded view and parts list

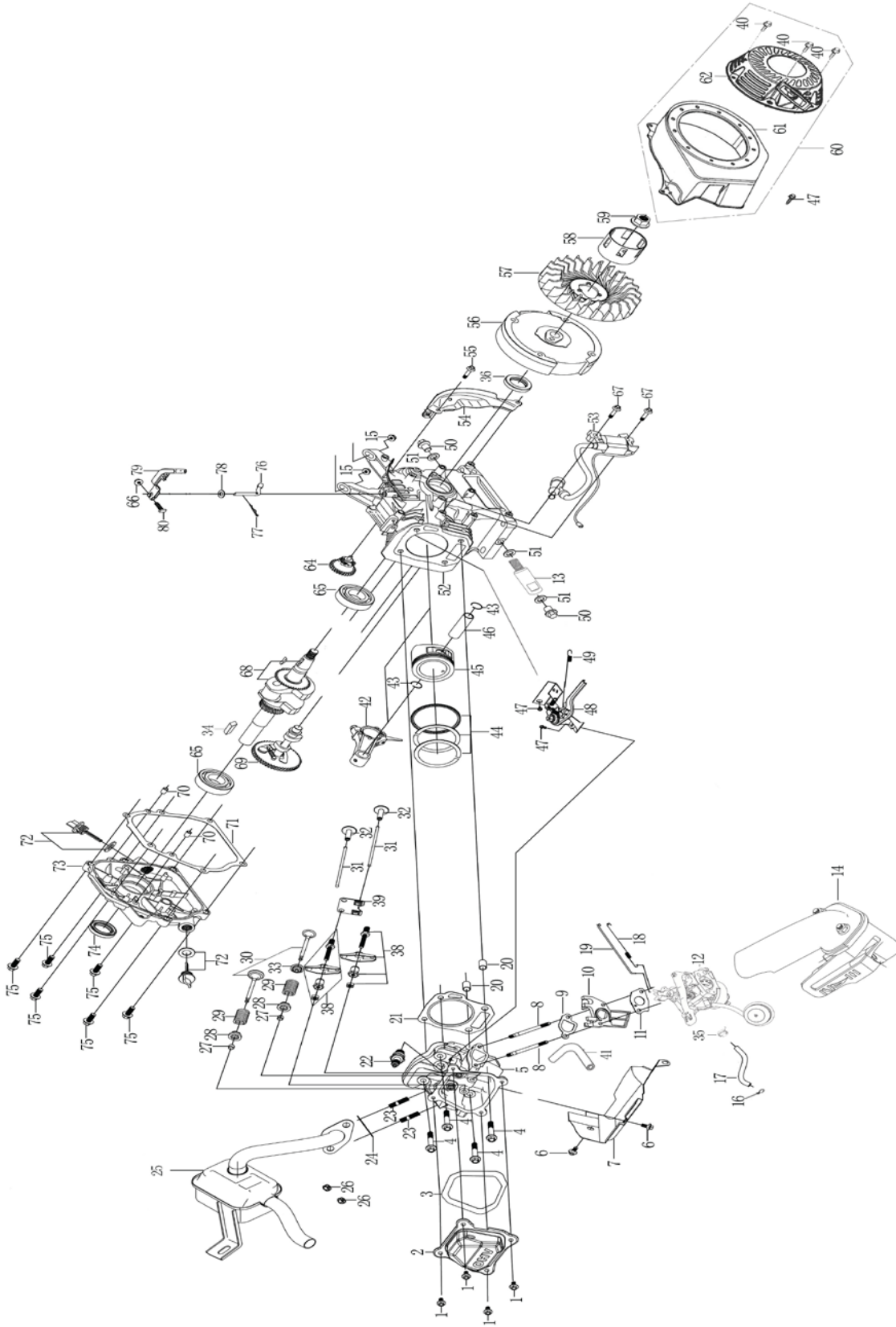

Item	Stock #	Description	Qty
1	380140215-0003	Bolt M6x14	4
2	120220031-0001	Cylinder head cover	1
3	120250013-0001	Head cover gasket	1
4	380140336-0001	Bolt M8x60	4
5	120080276-0001	Cylinder head	1
6	380140089-0003	Bolt M6x8	2
7	160190009-0001	Air deflector	1
8	380180093-0001	Stud M6x113	2
9	170430060-0001	Carburetor gasket	1
10	170440089-0001	Heat insulating pad	1
11	170430048-0001	Carburetor gasket	1
12	170021923-0001	Carburetor	1
13	110940004-0001	Extension bar	1
14	180020806-0001	Air filter	1
15	380370048-0001	Nut M6	2
16	380950193-0001	Pipe clip	1
17	380750963-0001	Oil tube	1
18	171610002-0001	Throttle return spring	1
19	171590004-0001	Throttle rod	1
20	380600117-0001	Pin	2
21	120150070-0001	Head Gasket	1
22	270960014-0001	Spark plug	1
23	380180098-0001	Stud M8x34	2
24	180650065-0001	Outlet gasket	1
25	180572236-0001	Muffler	1
26	380340005-0005	Nut M8	2
27	140320001-0001	Valve adjustment cap	2
28	140380017-0001	Retainer	2
29	140340022-0001	Inner spring	2
30	500550069-0001	Valve Kit	1
31	140670004-0001	Push rod	2
32	140690003-0001	Valve lifter	2
33	140400011-0001	Valve oil seal	1
34	380620057-0001	Key	1
35	380960120-0004	Clip combination	1
36	380650490-0001	Oil seal	1
38	140450022-0001	Valve rocker	2
39	140710001-0001	Guide plate	1
40	380140531-0001	Bolt M6x8	3

Item	Stock #	Description	Qty
41	380740696-0001	Breather tube	1
42	130150039-0001	Connecting rod	1
43	380560056-0001	Pin ring	2
44	130070079-0001	Piston ring combination	1
45	130030083-0001	Piston	1
46	130060031-0001	Piston pin	1
47	380140011-0004	Bolt M6x10	7
48	171680108-0001	Throttle handle	1
49	171600070-0002	Governing spring	1
50	110260025-0001	Sealing plug screw	2
51	380450514-0001	Flat washer	3
52	110810196-0001	Crankcase	1
53	270920402-0001	Ignition coil	1
54	160200012-0001	Side plate	1
55	380140003-0005	Bolt M6x20	1
56	270020097-0001	Flywheel	1
57	160180007-0001	Impeller	1
58	193590005-0001	Starting cup	1
59	380370051-0001	Nut M14x1.5	1
60	193490451-0001	Recoil starter assembly	1
61	160210005-T050	Fan cover	1
62	193500008-T050	Recoil starter	1
64	171750001-0001	Governor gear	1
65	380630137-0002	Bearing	2
66	380370066-0001	Nut M6	1
67	380140102-0004	Bolt M6x25	2
68	130290611-0001	Crankshaft	1
69	140020114-0001	Camshaft	1
70	380600120-0001	Pin	2
71	110830007-0001	Crankcase gasket	1
72	110690096-0004	Dipstick	2
73	110820014-0001	Crankcase cover	1
74	380650491-0001	Oil seal	1
75	380140028-0004	Bolt M8x32	6
76	171630001-0001	Speed regulating arm	1
77	381350004-0001	Pin clip	1
78	380450531-0001	Flat washer	1
79	171620001-0003	Speed regulating bracket	1
80	380250002-0001	Square head screw	1

## **TWO (2) YEARS LIMITED WARRANTY**

PowerSmart is committed to building tools that are dependable for years. Our warranties are consistent with our commitment and dedication to quality.

### **TWO (2) YEARS LIMITED WARRANTY OF POWER SMART PRODUCTS FOR HOME USE.**

PowerSmart ("Seller") warrants to the original purchaser only, that all PowerSmart consumer power tools will be free from defects in material or workmanship for a period of two (2) years from date of purchase. Ninety (90) days for all PowerSmart Products, if the tool is used for professional or commercial use.

**SELLER'S SOLE OBLIGATION AND YOUR EXCLUSIVE REMEDY** under this Two (2) Years Limited Warranty and, to the extent permitted by law, any warranty or condition implied by law, shall be the repair or replacement of parts, without charge, which are defective in material or workmanship and which have not been misused, carelessly handled, or misrepaired by persons other than Seller or Authorized Service Center. To make a claim under this Limited Warranty, you must return the entire power tool product; transportation prepaid, to PowerSmart Include a legible copy of the original receipt, which lists the date of purchase (month and year) and the name of the company purchased from.

**THIS LIMITED WARRANTY DOES NOT APPLY TO ANY ACCESSORY ITEMS INCLUDED WITH THE TOOL SUCH AS CIRCULAR SAW BLADES OTHER RELATED ITEMS OR TO ANY REPLACEMENT PARTS LISTED UNDER MAINTENANCE.**

**ANY IMPLIED WARRANTIES SHALL BE LIMITED IN DURATION TO TWO (2) YEARS FROM DATE OF PURCHASE. SOME STATES IN THE U.S. AND SOME CANADIAN PROVINCES DO NOT ALLOW LIMITATIONS ON HOW LONG AN IMPLIED WARRANTY LASTS, SO THE ABOVE LIMITATION MAY NOT APPLY TO YOU.**

**IN NO EVENT SHALL SELLER BE LIABLE FOR ANY INCIDENTAL OR CONSEQUENTIAL DAMAGES (INCLUDING BUT NOT LIMITED TO LIABILITY FOR LOSS OF PROFITS) ARISING FROM THE SALE OR USE OF THIS PRODUCT. SOME STATES IN THE U.S. AND SOME CANADIAN PROVINCES DO NOT ALLOW THE EXCLUSION OR LIMITATION OF INCIDENTAL OR CONSEQUENTIAL DAMAGES, SO THE ABOVE LIMITATION OR EXCLUSION MAY NOT APPLY TO YOU.**

**THIS LIMITED WARRANTY GIVES YOU SPECIFIC LEGAL RIGHTS, AND YOU MAY ALSO HAVE OTHER RIGHTS WHICH VARY FROM STATE TO STATE IN THE U.S., PROVINCE TO PROVINCE IN CANADA AND FROM COUNTRY TO COUNTRY.**

For questions / comments, technical assistance or repair parts –  
Please call toll free at: 1-800-791-9458 M-F 9am – 5pm EST (USA)  
1-888-980-4937 M-F 9am – 5pm EST (Canada)  
Email: [support@amerisuninc.com](mailto:support@amerisuninc.com)

**SAVE YOUR RECEIPTS. THIS WARRANTY IS VOID WITHOUT THEM.**