

1.7 Cu. Ft. ENERGY STAR® Qualified Compact Refrigerator

HC17SF15RW

Available



Unit Specifications

Width	18 7/8"
Depth	17 7/8"
Height	19 3/8"
Weight	34 lbs.
UPC	688057308616 (White) 688057308623 (Black)

More Easy-To-Use Features

- Half-width Freezer Compartment
- Full-width Slide-out Wire Shelf
- Full-width and Half-width Door Storage Shelf
- 2 Liter Bottle Storage
- Space Saving Flat back Design
- Manual Defrost
- Adjustable Thermostat

Warranty

- 1 Year Warranty (Parts and Labor)
- 5 Year Sealed System

Available Finishes



HC17SF15RW



HC17SF15RB

Signature Features

Energy Star

Meets the ENERGY STAR energy efficiency requirements

2-Liter Bottle Storage

Store 2-liter and other tall bottles easily in the door compartment

Half-Width Freezer Compartment

Spacious storage for keeping items extra cold

Full & Half-Width Door Storage

Two separate racks provide extra storage space for all food storage needs



Letter	Unit Dimension	in.
A	Height	19 3/8"
B	Depth	17 7/8"
C	Width	18 7/8"

Clearances	
Back	4"
Sides	4"
Top	4"

Power Requirements	
Electrical Rating	115V, 60Hz
Energy Use	200kWh
Refrigerant	R600a

Overall Packaging Details	
Packaging	lb./in.
Gross Weight	34 lb.
Dimensions	W 19 1/2"
	D 18 5/16"
	H 19 7/8"

Product Technical Illustration

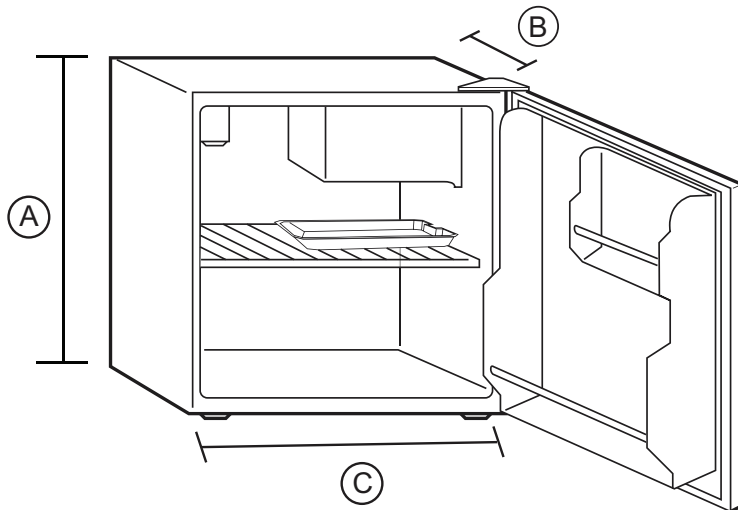

*Household Use

*Freestanding Installation only

General Appliance Information

Please read all installation details and instructions before use.

Contact Us

For questions regarding this product please refer to our website at haieramerica.com or call our customer service center at 877-337-3639.

