

# 31545 FORD EXPLORER & SPORT TRAC, MERCURY MOUNTAINEER

7/1/08

GROSS LOAD CAPACITY WHEN USED AS A WEIGHT CARRYING HITCH: 5,000 LBS. TRAILER WEIGHT & 500 LBS. TONGUE WEIGHT.

GROSS LOAD CAPACITY WHEN USED AS A STRAIGHT LINE PULL: 9,000 LBS. MAX. LINE PULL.

**\*\*\*DO NOT EXCEED VEHICLE MANUFACTURER'S RECOMMENDED TOWING CAPACITY.\*\*\***

Parts List			
ITEM	QTY	PART NUMBER	DESCRIPTION
1	2	1/2-13 x 4	CARRIAGE BOLT
2	4	1/2-13 x 1 3/4	CARRIAGE BOLT
3	2	CM-SP1	.250 x 1.50 x 2.00" SQUARE HOLE SPACER
4	4	CM-SP6	.250 x 1.00 x 3.00" SQUARE HOLE SPACER
5	2	CM-SP28	.250 x 3.00 x 4.00" SQUARE HOLE SPACER
6	6	HFN 1213	HEX FLANGE NUT
7	2	1_2 FISHWIRE	1/2" FISHWIRE

## FISHWIRE TECHNIQUE

INSERT COILED END OF FISHWIRE TOOL THROUGH HITCH MOUNTING HOLE IN VEHICLE FRAME RAIL AND OUT THE ACCESS HOLE. PASS COILED END OF FISHWIRE THROUGH SPACER AND THREAD BOLT INTO COIL. KINK WIRE TO KEEP SPACER SEPERATE FROM BOLT AS SHOWN. PULL FISHWIRE, SPACER, AND BOLT THROUGH FRAME AND OUT MOUNTING HOLE. USE FISHWIRE TO GUIDE HITCH DURING MOUNTING AND PREVENT LOSS OF BOLT / SPACER INSIDE FRAME RAIL.

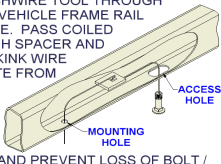

\*\*NOTE: SOME VEHICLES MAY FISHWIRE THROUGH END OF FRAME\*\*

**MOUNTING HOLE**  
FISHWIRE FASTENERS THROUGH HOLE IN OTHER SIDE OF FRAME RAIL (BOTH FRAMES)

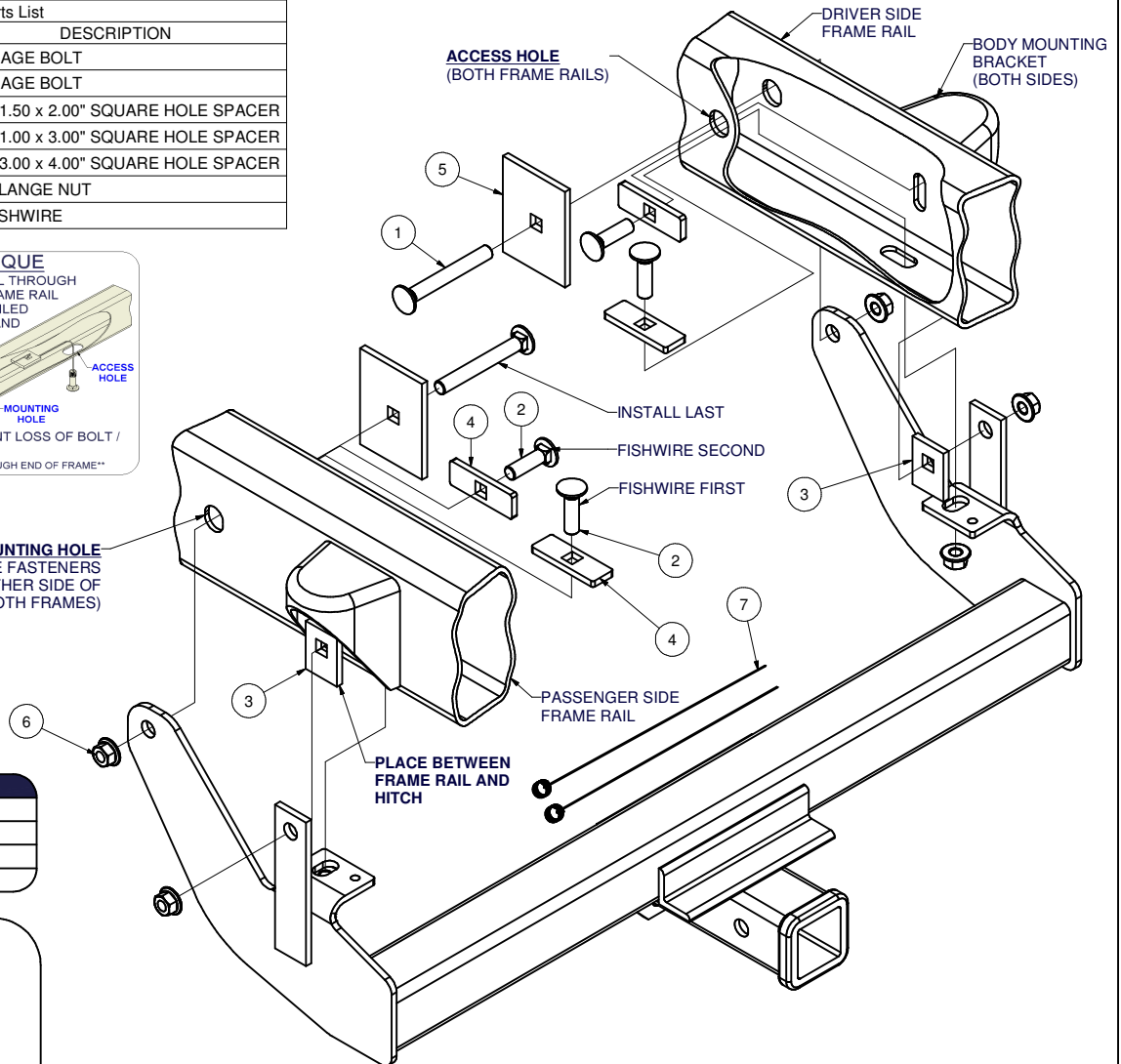

## TOOLS REQUIRED

RATCHET  
3/4" SOCKET  
6" EXTENSION  
TORQUE WRENCH

HITCH WEIGHT: 37 LBS.

INSTALL TIME: 30 MINUTES

INSTALL NOTES:

- NO DRILLING REQUIRED
- MUST FISHWIRE HARDWARE

## INSTALLATION STEPS

- 1) Fishwire a 1 3/4" long carriage bolt (#2) and CM-SP6 (#4) through access hole and into bottom of frame rail. Fishwire a 1 3/4" long carriage bolt and CM-SP6 through the same access hole but leave in frame until later - **leave fishwire attached**. Repeat for other side.
- 2) Pass fishwire through the CM-SP1 (#3) on each fishwire and the hole in the mounting tabs on the hitch. Slide the hitch up the fishwires into position and pull the bolts through the mounting tabs. Loosely install (4) 1/2" hex flange nuts (#6) on fishwired bolts.
- 3) Install 4" long carriage bolts and the large CM-SP28 (#5) spacers THROUGH the frame and hitch, install remaining flange nuts.
- 4) Torque all 1/2" fasteners to 75 lb-ft.

**PERIODICALLY CHECK THIS RECEIVER HITCH TO ENSURE THAT ALL FASTENERS ARE TIGHT AND THAT ALL STRUCTURAL COMPONENTS ARE SOUND.**

Curt Manufacturing Inc., warrants this product to be free of defects in material and/or workmanship at the time of retail purchase by the original purchaser. If the product is found to be defective, Curt Manufacturing Inc., may repair or replace the product, at their option, when the product is returned, prepaid, with proof of purchase. Alteration to, misuse of, or improper installation of this product voids the warranty. Curt Manufacturing Inc.'s liability is limited to repair or replacement of products found to be defective, and specifically excludes liability for incidental or consequential loss or damage.

# 31545 FORD EXPLORER & SPORT TRAC, MERCURY MOUNTAINEER

**\*\*\*DO NOT EXCEED VEHICLE MANUFACTURER'S RECOMMENDED TOWING CAPACITY \*\*\*.**

## FRONT MOUNTED ACCESSORIES

1) Do not exceed front axle Gross Weight Rating (GAWR). Consult owners manual or specification plate located on driver's door frame. Measure gross front axle weight by placing front wheels of loaded vehicle on a scale.

**WARNING:** Exceeding GAWR may overload the front axle and/or suspension. This could result in **accident, property damage and personal injury.**

- 2) Reposition front mounted license plate if obstructed.
- 3) Do not obstruct vehicle lights.
- 4) Allow free air flow into grille opening.
- 5) Rear wheel traction may be reduced. This could effect handling. Reduce speed and drive with caution.
- 6) Accessories extend front of vehicle. This may reduce approach angle. Use caution when parking and maneuvering.
- 7) Do not obstruct driver view.

## VEHICLE RECOVERY AND WINCHING TIPS

1) Use OEM tow hooks, recovery eyes or a clevis mount for attachment of a tow strap or winch cable.

**WARNING: NEVER** use a ball and/or ball mount as an anchor point for tow strap or winch cable. Severe personal injury or death could result.

- 2) Observe winch manufacturer's recommendations, cautions and warnings.
- 3) Attach return cable to tow hook or recovery eye when using a snatch block (See figure 1).

**CAUTION:** Do not attach return cable to winch mount. This may overload winch mount and/or front mounted receiver.

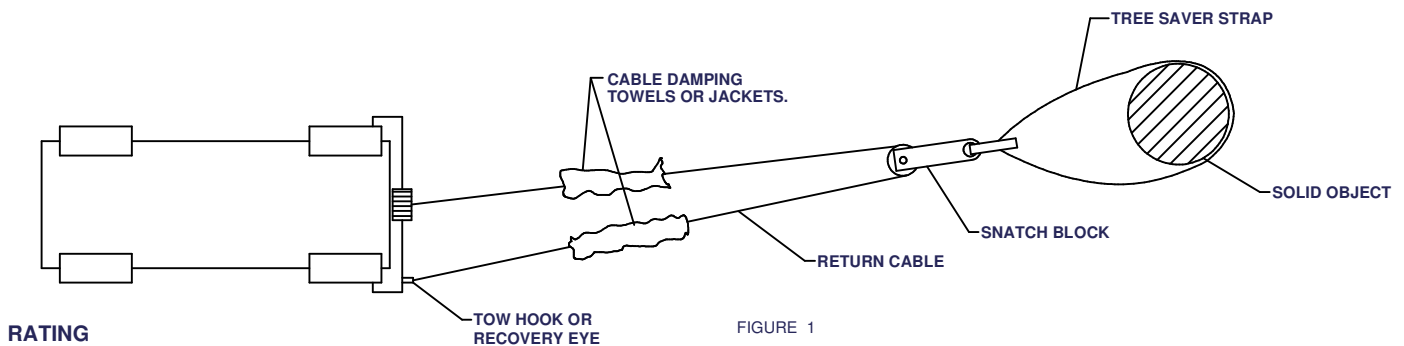

For **Maximum** line pull rating, winch cable must not exceed:

- 15 degree angle up or down from horizontal (See Figure 2).
- 45 degree angle left or right from straight ahead (See Figure 3).

**CAUTION:** Exceeding the maximum line pull rating may over load winch, winch mount, and/or front mounted receiver.

